

LOW POWER NARROW BAND FM IF MC3361

DESCRIPTION

The MC3361 is designed for use in FM dual conversion communication. It contains a complete narrow band FM demodulation system operable to less than 2.0V supply voltage. This low power narrow band FM IF system provides the second converter, second IF, demodulator. Filter Amp and squelch circuitry for communications and scanning receivers.

Outline Drawing

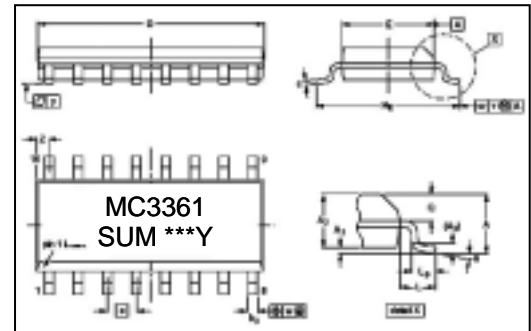

FEATURE

- Operating voltage range : 2.0V ~ 8.0V
- Low Current consumption $I_{cc}=4.0\text{mA}$ Typ. ($V_{cc}=4.0\text{V}$)
- Excellent input sensitivity (-3dB Limiting = 2.0 μV_{rms} Typ.)
- Low number of external parts required
- Operating frequency up to 60MHz

PIN CONFIGURATION

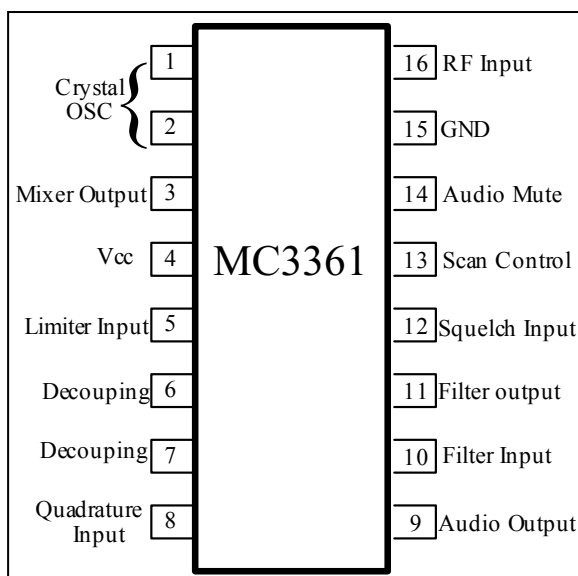
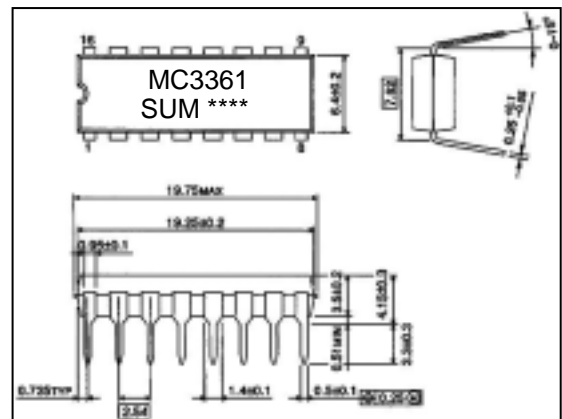

MC3361

ABSOLUTE MAXIMUM RATINGS (Ta=25°C)

Characteristic	Symbol	Value	Unit
Maximum Supply Voltage	V _{CC(MAX)}	10	V
Supply Voltage Range	V _{CC}	2.0~8.0	V
Detector Input Voltage	V _{IN(DET)}	1.0	V _{p-p}
RF Input Voltage	V _{IN(RF)}	1.0	V _{rms}
Mute Function	V _{MUTE}	-0.5~+5.0	V _{peak}
Operating Temperature	T _{opr}	-20~+70	°C
Storage Temperature	T _{stg}	-65~150	°C

ELECTRICAL CHARACTERISTICS

(Unless otherwise specified: Ta=25°C, V_{CC}=4V, fo=10.7MHz, fm=1kHz, Δf=±3kHz)

Characteristics	Symbol	Test conditions	Min	Typ	Max	Unit
Squelch Current	I _{CC1}	Squelch off (V _{I2} =2V)	2.9	3.9	4.9	mA
	I _{CC2}	Squelch on (V _{I2} =0V)	4.4	5.4	6.4	
Audio Output Voltage	V _{OUT}	V _{in} =10mV _{rms}	130	160	200	mV _{rms}
Input Limiting Voltage	V _{IN(Lim)}	-3dB Limiting		2.0	6.0	μV
Total Harmonic Distortion	THD	V _{OUT} =170mV _{rms}		0.8		%
Recovered Output Noise Voltage	V _{NO}	No Input Signal	60	80	250	mV _{rms}
Drop Voltage AF Gain Loss	ΔG _V	V _{CC} =4V → 2V	-3	-0.6		dB
Detector Output Resistance	R _{OUT}			450		Ω
Signal to Noise Ratio	S/N		36	67		dB
Filter Gain	G _V	V _{in} =5mV _{rms} , f=10kHz	40	50		dB
Filter Output DC Voltage	V _{O(DC)}		1.0	1.3	1.6	V _{DC}
Mute Low Resistance	R _{ON(Mute)}	Mute Switch-on		10		Ω
Mute High Resistance	R _{Off(Mute)}	Mute Switch-off	1.0	10		MΩ
Scan Control Low	V _{L(Scan)}	Mute off(V _{I2} =2V)		0	0.4	V _{DC}
Scan Control High	V _{H(Scan)}	Mute on(V _{I2} =0V)	3.0	3.5		V _{DC}
Trigger Hysteresis	V _{TH}	Squelch on/off		45	100	mV _{rms}
Mixer Conversion Gain	G _{V(Mix)}			28		dB
Mixer Input Resistance	R _{i(Mix)}			3.3		kΩ
Mixer Input Capacitance	C _{i(Mix)}			2.2		pF

MC3361

BLOCK DIAGRAM AND TEST CIRCUIT

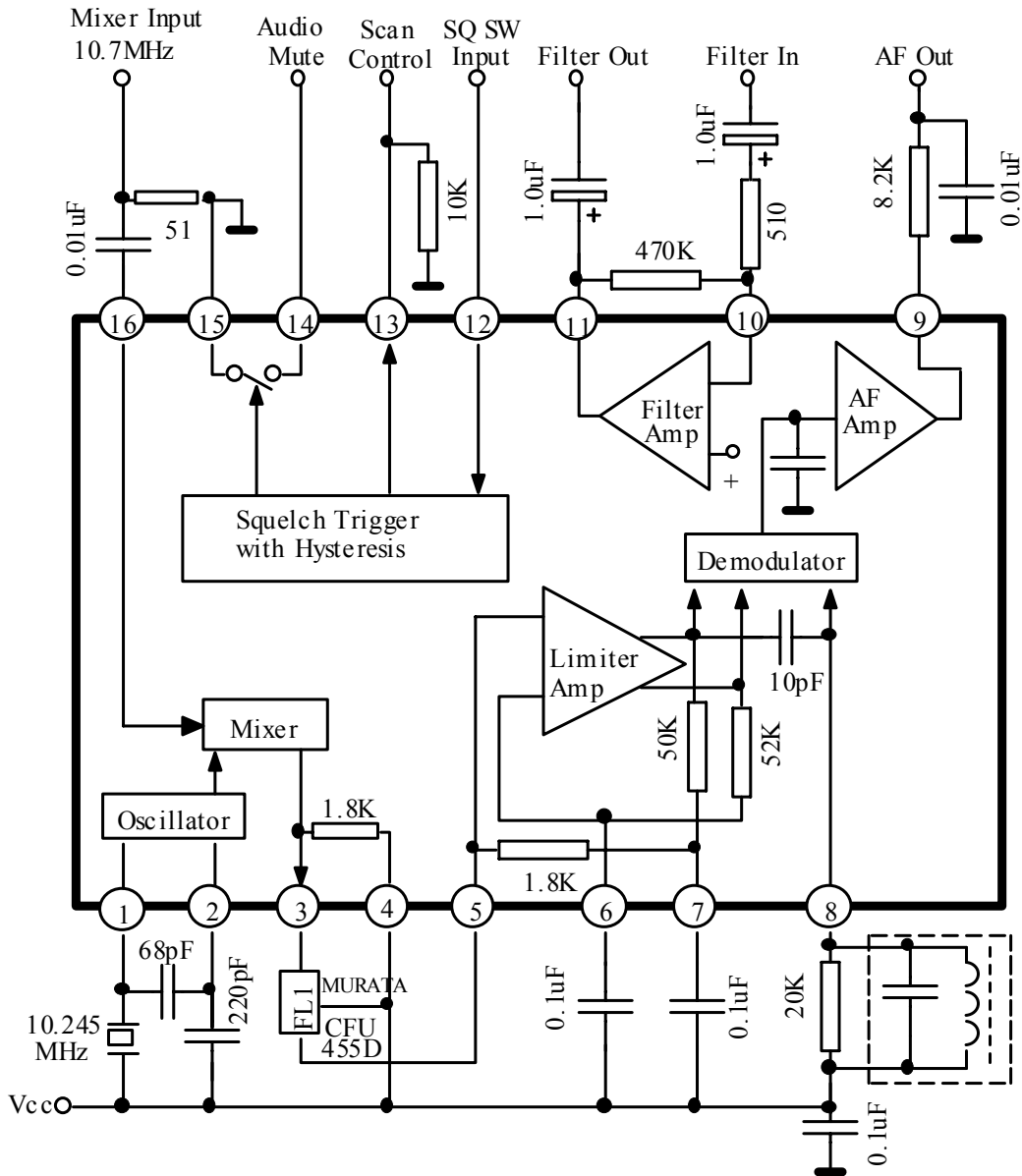

MC3361

APPLICATION CIRCUIT

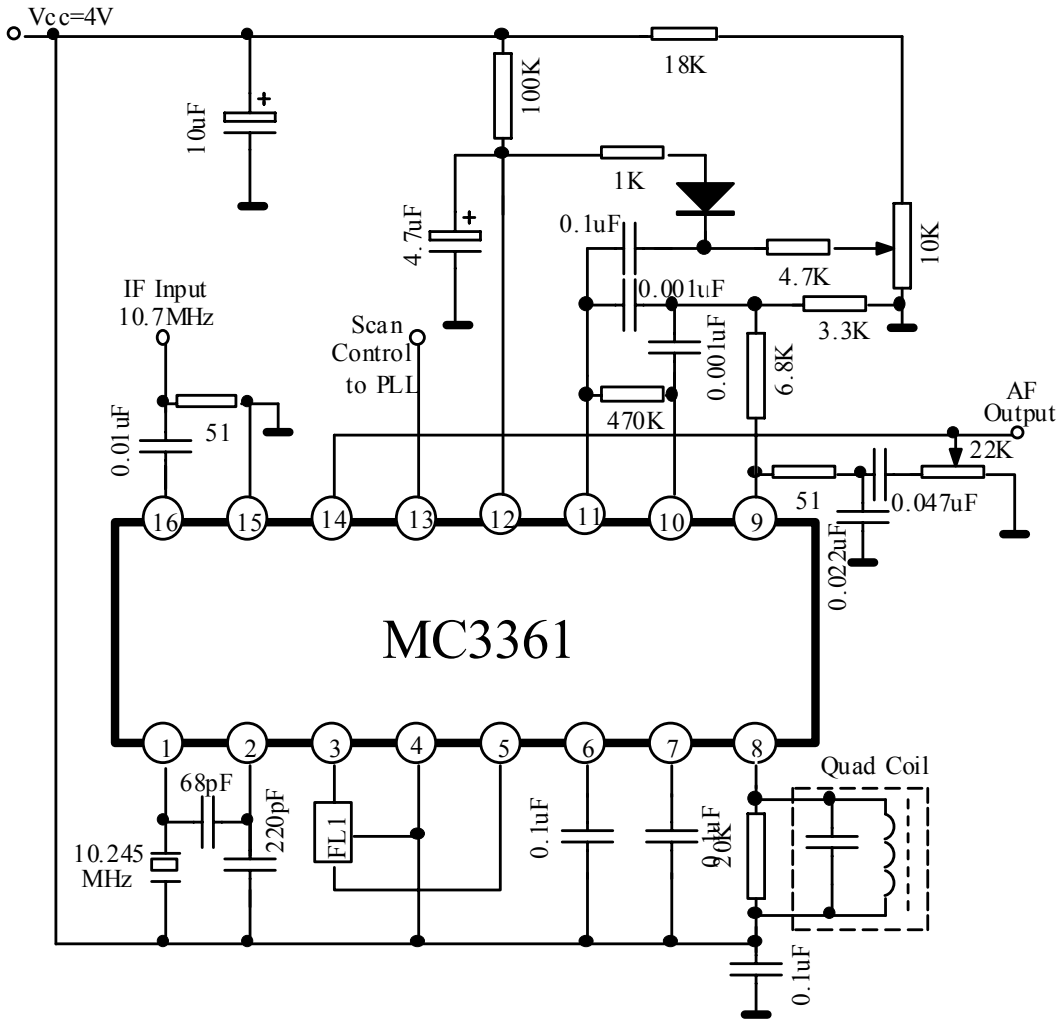

TYPICAL PERFORMANCE CHARACTERISTICS

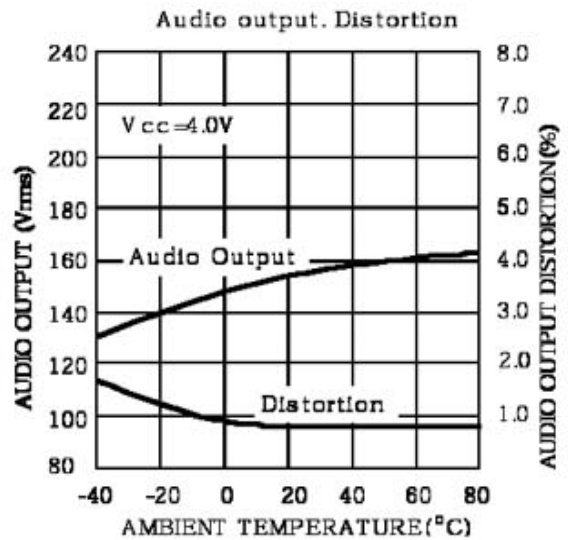
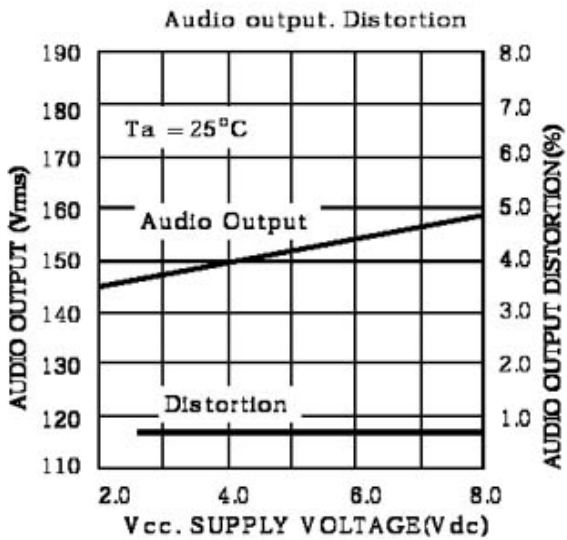

MC3361

