

MC3361C

Low Power Narrowband FM IF

The MC3361C includes an Oscillator, Mixer, Limiting Amplifier, Quadrature Discriminator, Active Filter, Squelch, Scan Control and Mute Switch. This device is designed for use in FM dual conversion communications equipment.

- Operates from 2.0 to 8.0 V Supply
- Low Drain Current 2.8 mA Typical @ $V_{CC} = 4.0$ Vdc
- Excellent Sensitivity: Input Limiting Voltage –
– 3.0 dB = 2.6 μ V Typical
- Low Number of External Parts Required
- Operating Frequency Up to 60 MHz
- Full ESD Protection

LOW POWER NARROWBAND FM IF

SEMICONDUCTOR TECHNICAL DATA

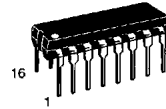

P SUFFIX
PLASTIC PACKAGE
CASE 648

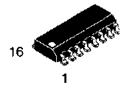

D SUFFIX
PLASTIC PACKAGE
CASE 751B
(SO-16)

Representative Block Diagram

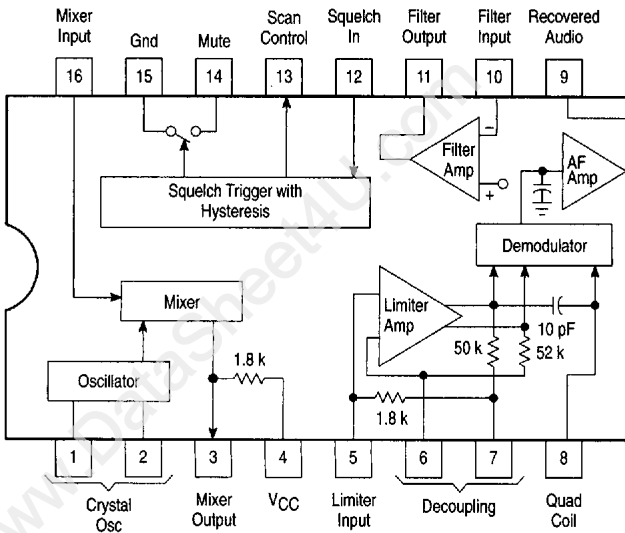

This device contains 92 active transistors.

PIN CONNECTIONS

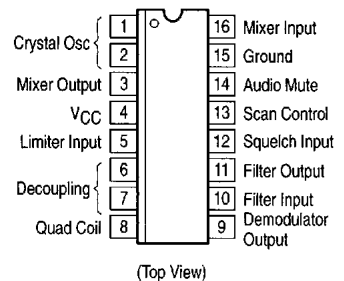

ORDERING INFORMATION

Device	Operating Temperature Range	Package
MC3361CD	$T_A = -30$ to $+70^\circ\text{C}$	SO-16
MC3361CP		Plastic DIP

MC3361C

MAXIMUM RATINGS (T_A = 25°C, unless otherwise noted.)

Rating	Pin	Symbol	Value	Unit
Power Supply Voltage	4	V _{CC(max)}	10	Vdc
Operating Supply Voltage Range	4	V _{CC}	2.0 to 8.0	Vdc
Detector Input Voltage	8	–	1.0	V _{p-p}
Input Voltage (V _{CC} ≥ 4.0 V)	16	V ₁₆	1.0	V _{RMS}
Mute Function	14	V ₁₄	–0.5 to +5.0	V _{pk}
Junction Temperature	–	T _J	150	°C
Operating Ambient Temperature Range	–	T _A	–30 to +70	°C
Storage Temperature Range	–	T _{stg}	–65 to +150	°C

ELECTRICAL CHARACTERISTICS (V_{CC} = 4.0 Vdc, f₀ = 10.7 MHz, Δf = ± 3.0 kHz, f_{mod} = 1.0 kHz, T_A = 25°C, unless otherwise noted.)

Characteristic	Pin	Min	Typ	Max	Unit
Drain Current (No Signal)	4	2.0	2.8	3.5	mA
		Squelch "Off"	3.7	5.2	
Recovered Audio Output Voltage (V _{in} = 10 mVrms)	9	130	170	210	mVrms
Input Limiting Voltage (–3.0 dB Limiting)	16	–	2.6	6.0	μV
Total Harmonic Distortion	9	–	0.86	–	%
Recovered Output Voltage (No Input Signal)	9	60	190	350	mVrms
Drop Voltage AF Gain Loss	9	–3.0	–0.6	–	dB
Detector Output Impedance	–	–	450	–	Ω
Filter Gain (10 kHz) (V _{in} = 0.3 mVrms)	–	40	50	–	dB
Filter Output Voltage	11	0.5	0.7	0.9	Vdc
Mute Function Low	14	–	30	50	Ω
Mute Function High	14	1.0	11	–	MΩ
Scan Function Low (Mute "Off") (V ₁₂ = 1.0 Vdc)	13	–	0	0.4	Vdc
Scan Function High (Mute "On") (V ₁₂ = Gnd)	13	3.0	3.9	–	Vdc
Trigger Hysteresis	–	–	45	100	mV
Mixer Conversion Gain	3	–	28	–	dB
Mixer Input Resistance	16	–	3.3	–	kΩ
Mixer Input Capacitance	16	–	9.0	–	pF

MC3361C

Figure 1. Test Circuit

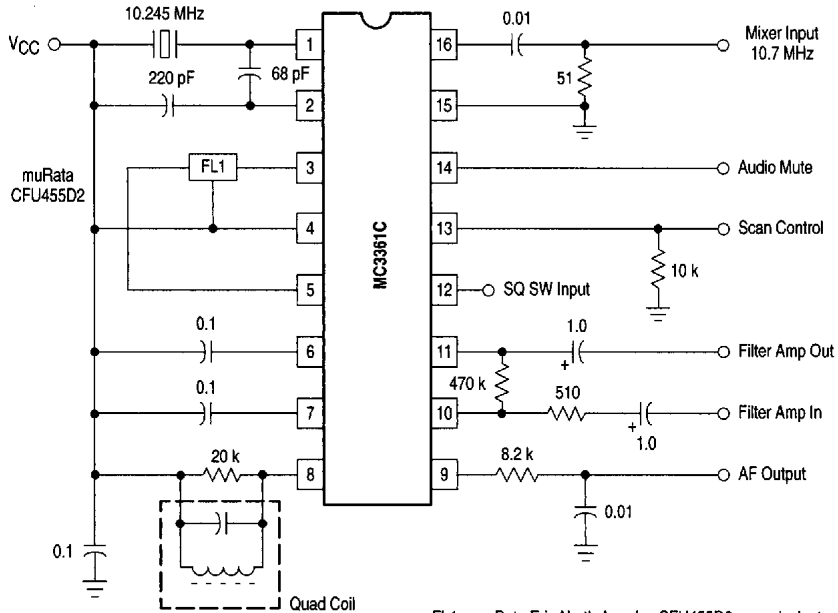

FL1 – muRata Erie North America CFU455D2 or equivalent

Quadrature Coil – Toko America Type 7MC-8128Z or equivalent

C – μF , unless noted

Figure 2. Audio Output, Distortion versus Supply Voltage

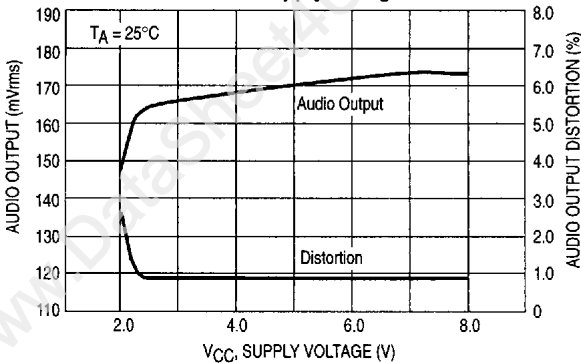
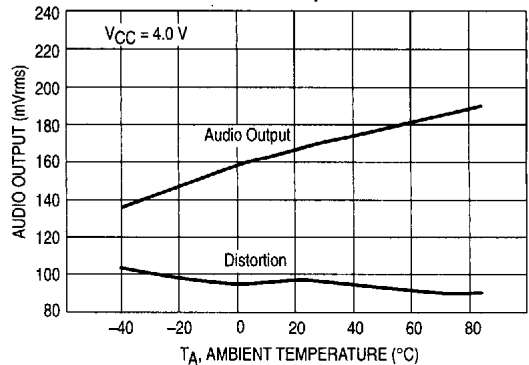
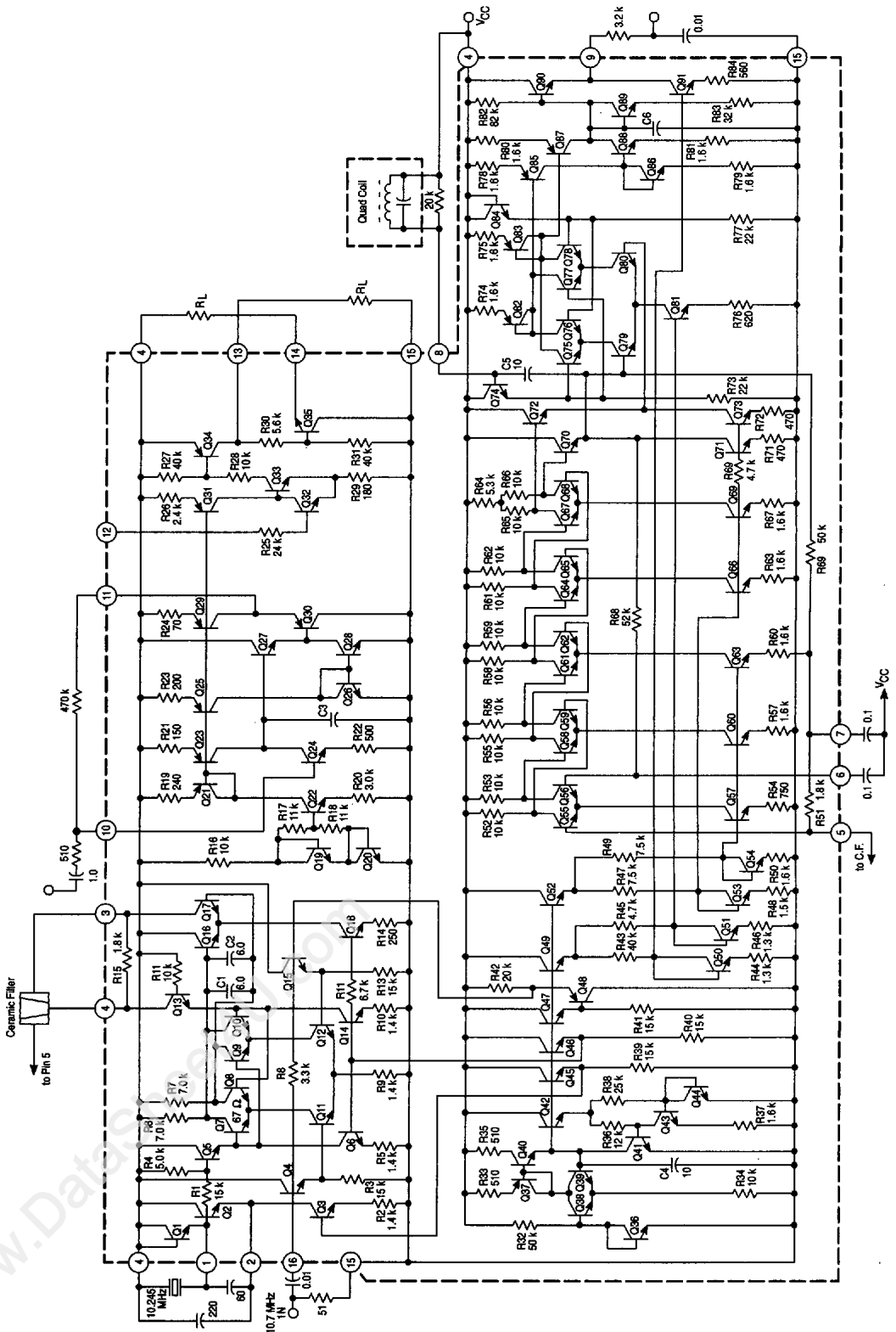

Figure 3. Audio Output, Distortion versus Temperature



MC3361C

Figure 4. Low Voltage Low Power Narrowband FM IF



MC3361C

Figure 5. Input Limiting Voltage

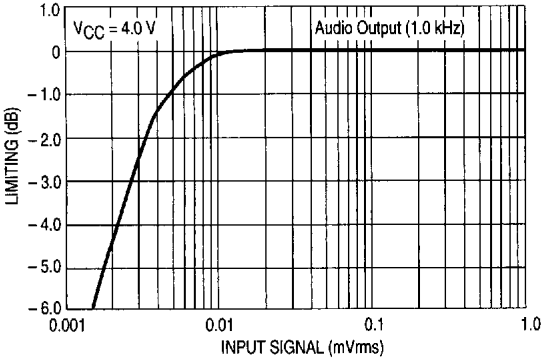

Figure 6. Overall Gain, Noise and AM Rejection

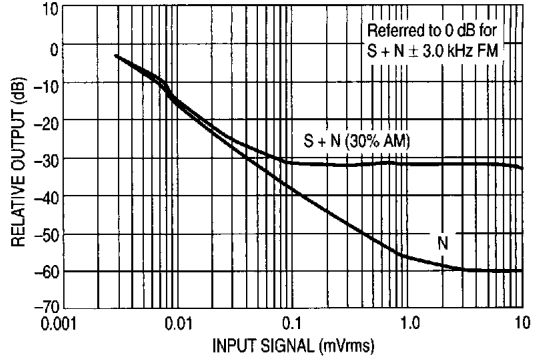

Figure 7. Filter Amp Response

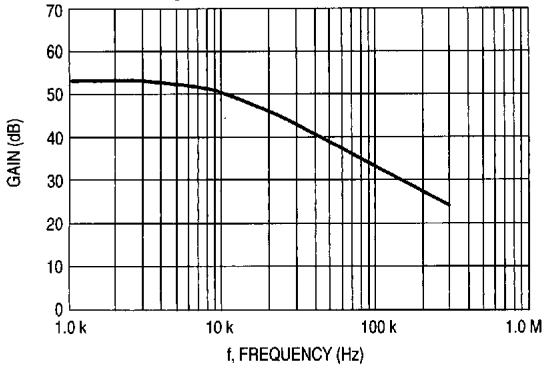

Figure 8. Filter Amp Gain

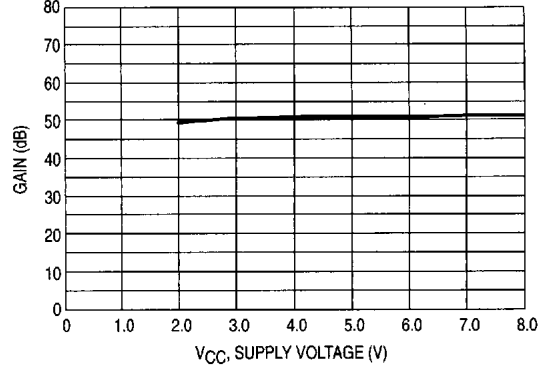
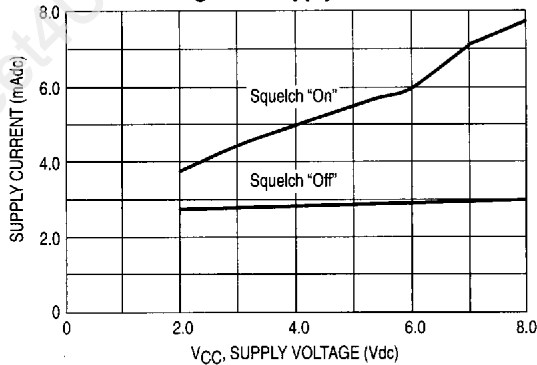
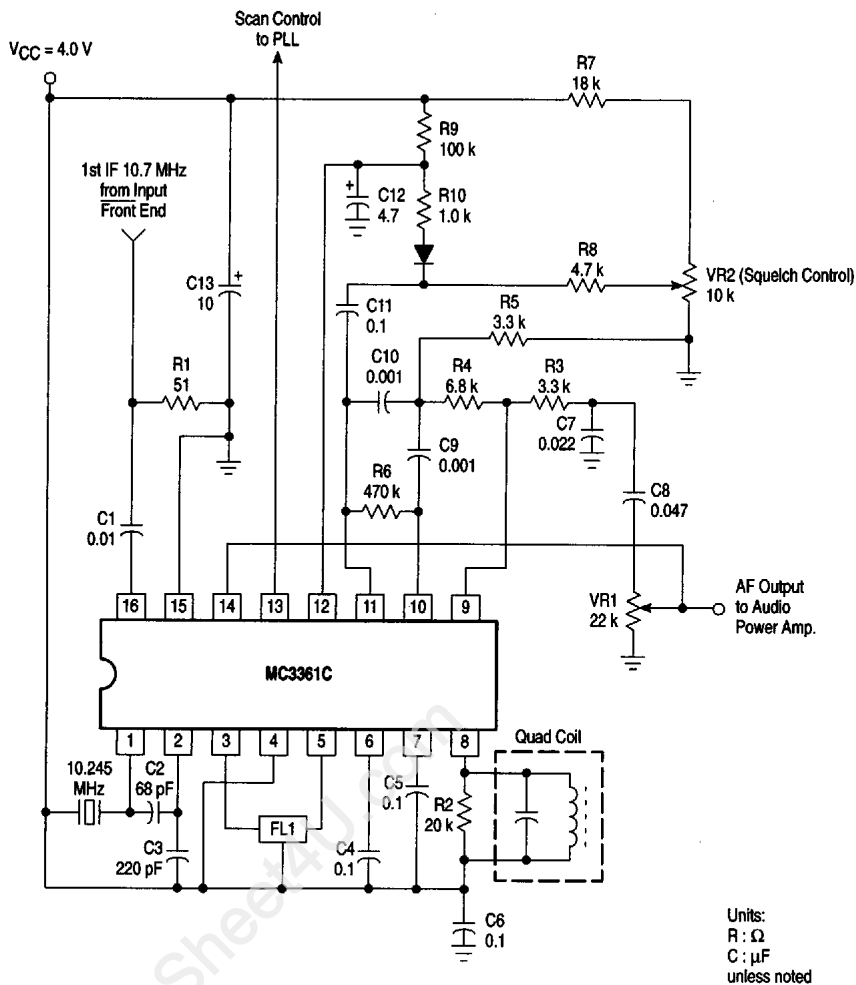

Figure 9. Supply Current



MC3361C

Figure 10. Simplified Application



FL1 - muRata Erie North America Type CFU455D2 or equivalent

Quadrature Coil - Toko America Type 7MC-8128Z or equivalent