



**MOTOROLA**

**MC3482A/MC6882A  
MC3482B/MC6882B**

**OCTAL THREE-STATE BUFFER/LATCH**

This series of devices combines four features usually found desirable in bus-oriented systems: 1) High impedance logic inputs insure that these devices do not seriously load the bus; 2) Three-state logic configuration allows buffers not being utilized to be effectively removed from the bus; 3) Schottky technology allows for high-speed operation; 4) 48 mA drive capability.

- Inverting and Non-Inverting Options of Data
- SN74S373 Function Pinouts
- Eight Transparent Latches/Buffers in a Single Package
- Full Parallel-Access for Loading and Reloading
- Buffered Control Inputs
- All Inputs Have Hysteresis to Improve Noise Rejection
- High Speed – 8.0 ns (Typ)
- Three-State Logic Configuration
- Single +5 V Power Supply Requirement
- Compatible with 74S Logic or M6800 Microprocessor Systems
- High Impedance PNP Inputs Assure Minimal Loading of the Bus

**OCTAL THREE-STATE  
BUFFER/LATCH**

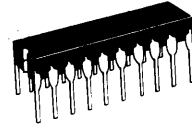

**L SUFFIX  
CASE 732-03**

**MICROPROCESSOR BUS EXTENDER APPLICATION**

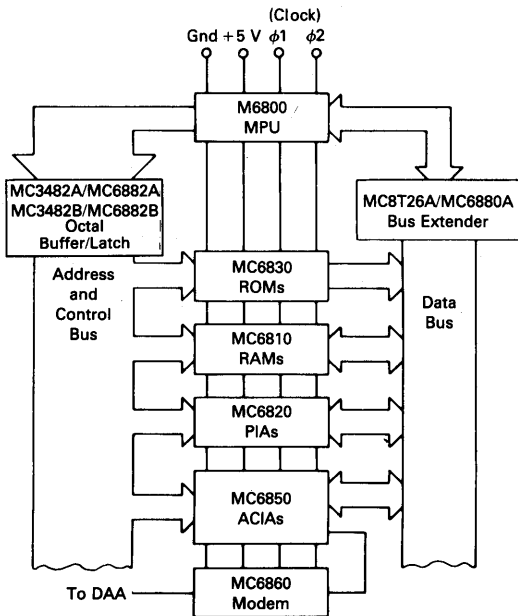

**INPUT EQUIVALENT  
CIRCUIT**

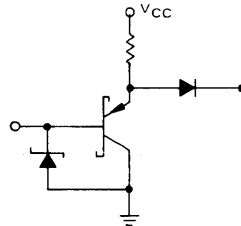

**OUTPUT EQUIVALENT  
CIRCUIT**

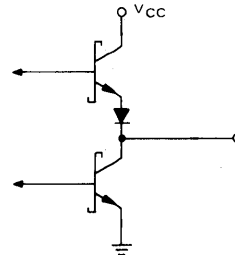

**ORDERING INFORMATION**

(Temperature Range for the following devices = 0 to +75°C.)

Device	Alternate	Package
MC3482AL	MC6882AL	Ceramic DIP
MC3482BL	MC6882BL	Ceramic DIP

# MC6882A, MC6882B, MC3482A, MC3482B

## MAXIMUM RATINGS (T<sub>A</sub> = 25°C unless otherwise noted.)

Rating	Symbol	Value	Unit
Power Supply Voltage	V <sub>CC</sub>	8.0	Vdc
Input Voltage	V <sub>I</sub>	5.5	Vdc
Operating Ambient Temperature Range	T <sub>A</sub>	0 to +75	°C
Storage Temperature Range	T <sub>stg</sub>	-65 to +150	°C
Operating Junction Temperature	T <sub>J</sub>		°C
Ceramic Package		175	

## ELECTRICAL CHARACTERISTICS (Unless otherwise noted, 0°C ≤ T<sub>A</sub> ≤ 75°C and 4.75 V ≤ V<sub>CC</sub> ≤ 5.25 V)

Characteristic	Symbol	Min	Typ	Max	Unit
Input Voltage – High Logic State (V <sub>CC</sub> = 4.75 V, T <sub>A</sub> = 25°C)	V <sub>IH</sub>	2.0	–	–	V
Input Voltage – Low Logic State (V <sub>CC</sub> = 4.75 V, T <sub>A</sub> = 25°C)	V <sub>IL</sub>	–	–	0.8	V
Input Current – High Logic State (V <sub>CC</sub> = 5.25 V, V <sub>IH</sub> = 2.4 V)	I <sub>IH</sub>	–	–	40	μA
Input Current – Low Logic State (V <sub>CC</sub> = 5.25 V, V <sub>IL</sub> = 0.5 V, V <sub>IL</sub> ( $\overline{OE}$ ) = 0.5 V)	I <sub>IL</sub>	–	–	-250	μA
Output Voltage – High Logic State (V <sub>CC</sub> = 4.75 V, I <sub>OH</sub> = -20 mA)	V <sub>OH</sub>	2.4	–	–	V
Output Voltage – Low Logic State (I <sub>OL</sub> = 48 mA)	V <sub>OL</sub>	–	–	0.5	V
Output Current – High Impedance State (V <sub>CC</sub> = 5.25 V, V <sub>OH</sub> = 2.4 V) (V <sub>CC</sub> = 5.25 V, V <sub>OL</sub> = 0.5 V)	I <sub>OZ</sub>	–	–	100 -100	μA
Output Short-Circuit Current (V <sub>CC</sub> = 5.25 V, V <sub>O</sub> = 0) (only one output can be shorted at a time)	I <sub>OS</sub>	-30	-80	-130	mA
Power Supply Current (V <sub>CC</sub> = 5.25 V)	I <sub>CC</sub>	–	–	130 150	mA
Input Clamp Voltage (V <sub>CC</sub> = 4.75 V, I <sub>IK</sub> = -12 mA)	V <sub>IK</sub>	–	–	-1.2	V

# MC6882A, MC6882B, MC3482A, MC3482B

SWITCHING CHARACTERISTICS ( $V_{CC} = 5.0\text{ V}$ ,  $0^\circ\text{C} \leq T_A \leq +75^\circ\text{C}$ , unless otherwise noted, typical @  $T_A = 25^\circ\text{C}$ .)

Characteristics	Symbol	MC3482A/ MC6882A			MC3482B/ MC6882B			Unit
		Min	Typ	Max	Min	Typ	Max	
Propagation Delay Times Data to Output Low to High $C_L = 50\text{ pF}$ $C_L = 250\text{ pF}$ $C_L = 375\text{ pF}$ $C_L = 500\text{ pF}$ High to Low $C_L = 50\text{ pF}$ $C_L = 250\text{ pF}$ $C_L = 375\text{ pF}$ $C_L = 500\text{ pF}$	$t_{PLH(D)}$      $t_{PHL(D)}$      	4.0 — — 10 4.0 — — 16	9.0 12 14 16 8.0 15 18 21	16 20 22 24 16 22 25 28	4.0 — — 10 4.0 — — 14	9.0 12 14 16 8.0 15 17 18	16 20 22 24 16 22 24 27	ns
Propagation Delay Times Latch Disable (Low to High) to Output Low to High $C_L = 50\text{ pF}$ High to Low $C_L = 50\text{ pF}$	$t_{PLH(L)}$   $t_{PHL(L)}$	— —	22 23	30 30	— —	18 14	30 25	ns
Propagation Delay Times ( $C_L = 20\text{ pF}$ ) High Output Level to High Impedance Low Output to High Impedance High Impedance to High Output High Impedance to Low Output	$t_{PHZ}(\overline{OE})$ $t_{PLZ}(\overline{OE})$ $t_{PZH}(\overline{OE})$ $t_{PZL}(\overline{OE})$	— — — —	8.0 20 9.0 13	15 27 16 20	— — — —	6.0 15 11 9.0	13 23 18 16	ns

3

AC SETUP CHARACTERISTICS ( $V_{CC} = 5.0\text{ V}$ ,  $0^\circ\text{C} \leq T_A \leq +75^\circ\text{C}$ , unless otherwise noted, typical @  $T_A = 25^\circ\text{C}$ .)

Characteristic	Symbol	MC3482A/ MC6882A			MC3482B/ MC6882B			Unit
		Min	Typ	Max	Min	Typ	Max	
Setup Time (Data to Negative Going Latch Enable)	$t_{su(D)}$	10	0	—	7.0	0	—	ns
Hold Time (Data to Negative Going Latch Enable)	$t_h(D)$	10	—	—	8.0	—	—	ns
Minimum Latch Enable Pulse Width (High or Low)	$t_w(L)$	—	15	—	—	15	—	ns

# MC6882A, MC6882B, MC3482A, MC3482B

## PIN CONNECTIONS AND TRUTH TABLES

3

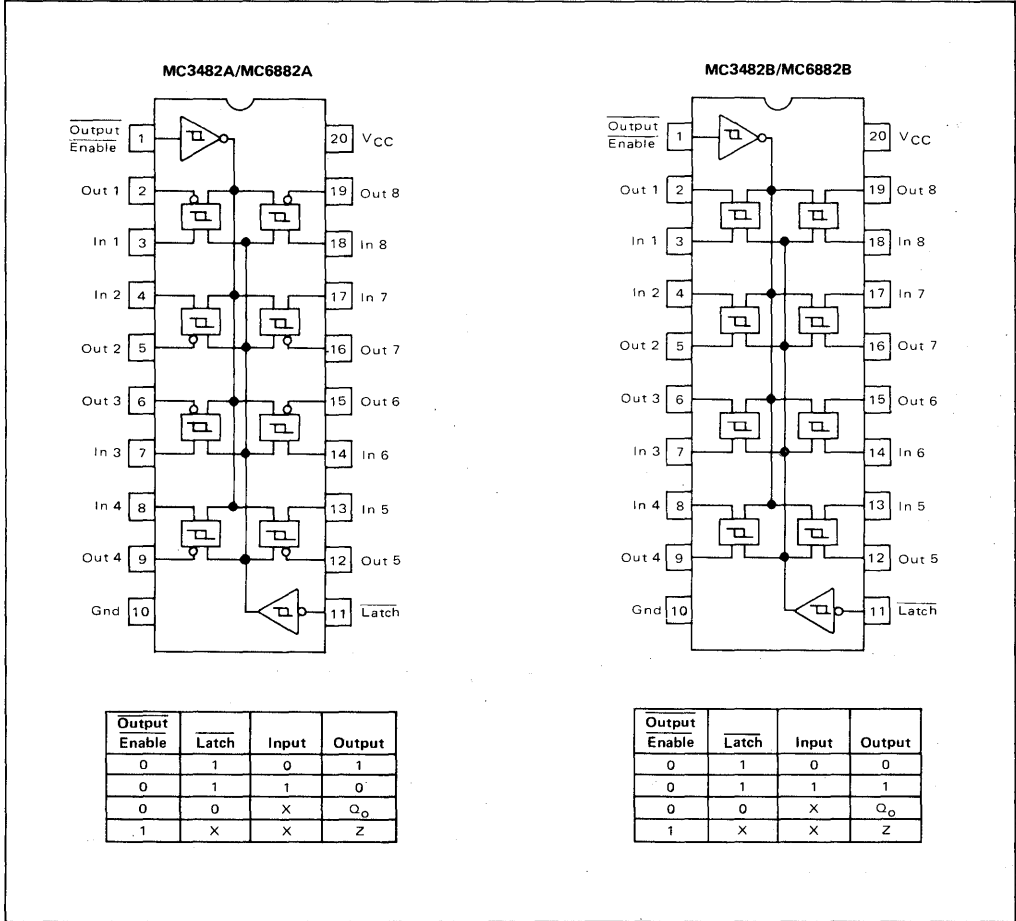

FIGURE 1 – TEST CIRCUIT FOR SWITCHING CHARACTERISTICS

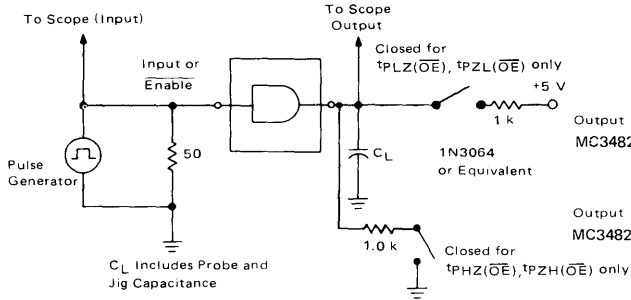

FIGURE 2 – WAVEFORMS FOR PROPAGATION DELAY TIMES DATA TO OUTPUT

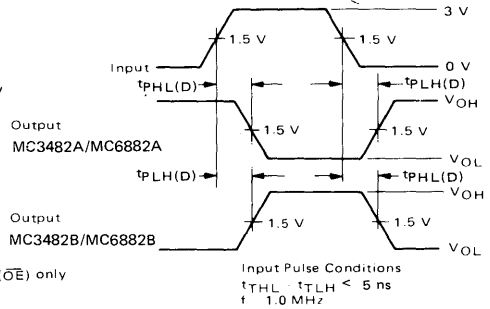

FIGURE 3 – WAVE FORMS FOR AC SETUP AND LATCH DISABLE TO OUTPUT DELAY

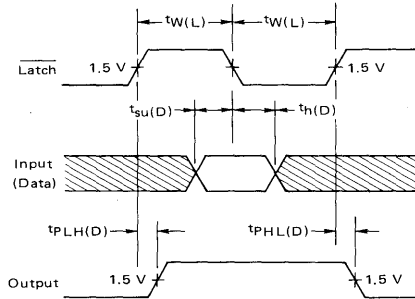

FIGURE 4 – WAVEFORMS FOR PROPAGATION DELAY TIMES – OUTPUT ENABLE TO OUTPUT

