

ABOV SEMICONDUCTOR Co., Ltd.
4-BIT SINGLE-CHIP MICROCONTROLLERS

MC41P6004 MC41P6104

User's Manual



REVISION HISTORY

Ver. 1.2 (Mar 30, 2012) This book

Added Notes for capacitor and IR LED resistor at application circuit diagram of last 2 pages.

Ver. 1.1 (Aug 3, 2011)

Removed 0.1uF bypass capacitor at the application circuit diagram.

Ver. 1.0.1 (Dec 28, 2010)

Added 0.1uF bypass capacitor at the application circuit diagram.

Ver. 0.5 (Dec 7, 2010)

Remove 16 TSSOP package type.

Ver. 0.4 (Oct 25, 2010)

Modified the test condition of Electrical characteristics (VDD= 3.6V -> VDD= 3V)

Ver. 0.1 (Nov 11, 2009)

First released version.

Version 1.2

Published by ABU

©2009 ABOV Semiconductor Co., Ltd. All rights reserved.

Additional information of this manual may be served by ABOV Semiconductor offices in Korea or Distributors. ABOV Semiconductor reserves the right to make changes to any information here in at any time without notice. The information, diagrams and other data in this manual are correct and reliable; however, ABOV Semiconductor is in no way responsible for any violations of patents or other rights of the third party generated by the use of this manual.

Table of Contents

1. OVERVIEW	4
1.1 Description.....	4
1.2 Features.....	4
1.3 Ordering Information	5
2. BLOCK DIAGRAM	6
2.1 MC41P6004 (20 pin package)	6
2.2 MC41P6104 (16 pin package)	7
3. PIN ASSIGNMENT (top view)	8
4. PACKAGE Dimension	9
5. PIN FUNCTION	12
6. PORT STRUCTURES	13
7. ELECTRICAL CHARACTERISTICS	14
7.1 Absolute Maximum Ratings (Ta = 25 °C)	14
7.2 Recommended Operating Conditions	14
7.3 Electrical characteristics (Ta=25 °C, V _{DD} = 3V).....	15
8. Architecture	18
8.1 Program Memory (EPROM).....	18
8.2 EPROM Address Register	19
8.3 Data memory(RAM) and Special function register(SFR).....	20
8.4 X-register (X).....	21
8.5 Y-register (Y).....	21
8.6 Accumulator (Acc)	21
8.7 Arithmetic and Logic Unit (ALU)	21
8.8 State Counter (SC).....	21
8.9 Pulse Generator.....	22
8.10 Carrier Generator	23
8.11 Reset Operation.....	25
8.12 STOP Operation.....	27
9. Instruction	28
9.1 Instruction Table	28
9.2 DETAILS OF INSTRUCTION SYSTEM.....	30
9.3 Assembler Macro	43
10. SPGM (Serial Program)	44
Summary of Protocol	44
OPTION PROGRAM / READ DATA Format	45
4K MTP (Multi Time Programming).....	46
11. APPLICATION CIRCUIT DIAGRAM	48

MC41P6004 MC41P6104

CMOS SINGLE-CHIP 4-BIT MICROCONTROLLER

1. OVERVIEW

1.1 Description

The MC41P6x004 series is 4-bit remote control MCU which uses CMOS technology and the 4K bytes EPROM version. This enables transmission code outputs of different configurations, multiple custom code output, and double push key output for easy fabrication. The MC41P6X004 series is suitable for remote control of TV, VCR, FANS, Air-conditioners, Audio Equipments, Toys, Games etc.

1.2 Features

- **Program memory : 4,096 bytes**
MTP : 1K * 4, 2K * 2, 4K * 1 times programmable
- **Data memory : 32 × 4 bits**
- **43 types of instruction set**
- **4 levels of subroutine nesting**
- **Instruction cycle : $f_{osc}/48$ or $f_{osc}/12$**
- **CMOS process (Single 3.0V power supply)**
- **Stop mode (Through internal instruction)**
- **Released stop mode by key input**
- **Built in Power-on Reset circuit**
- **Built in Transistor for I.R LED Drive**
 - $I_{OL} = 250$ mA at $V_{DD} = 3V$ and $V_O = 0.3V$
 - $I_{OL} = 500$ mA at $V_{DD} = 3V$ and $V_O = 0.52V$
- **Built in Low Voltage reset circuit**
- **Built in a watch dog timer (WDT)**
- **Built in Internal RC OSC :**
 - 3.64MHZ $\pm 1.0\%$ at Room Temperature**
 - 3.64MHZ $\pm 1.5\%$ at All Temperature range of -20~70°C**
- **Carrier Frequency generator : 1820.17KHZ ~ 7.11KHZ(@3.64MHZ)**
- **Load Word instruction (Table Read for program memory to RAM)**
- **Low operating voltage : 1.8 ~ 3.6V**
- **20 SOP/TSSOP, 16 SOPN package**

1.3 Ordering Information

Series	MC41P6004D	MC41P6004R	MC41P6104M
Program memory	4,096 Bytes		
Data memory	32 nibble (32 x 4bit)		
I/O Ports	2	2	2
Input Ports	6	6	4
Output Ports	9 (D0~D8)	9 (D0~D8)	7 (D0~D3, D5,D7,D8)
Built-in Drive Tr.	O	O	O
Package	20SOP	20TSSOP	16SOPN

2. BLOCK DIAGRAM

2.1 MC41P6004 (20 pin package)

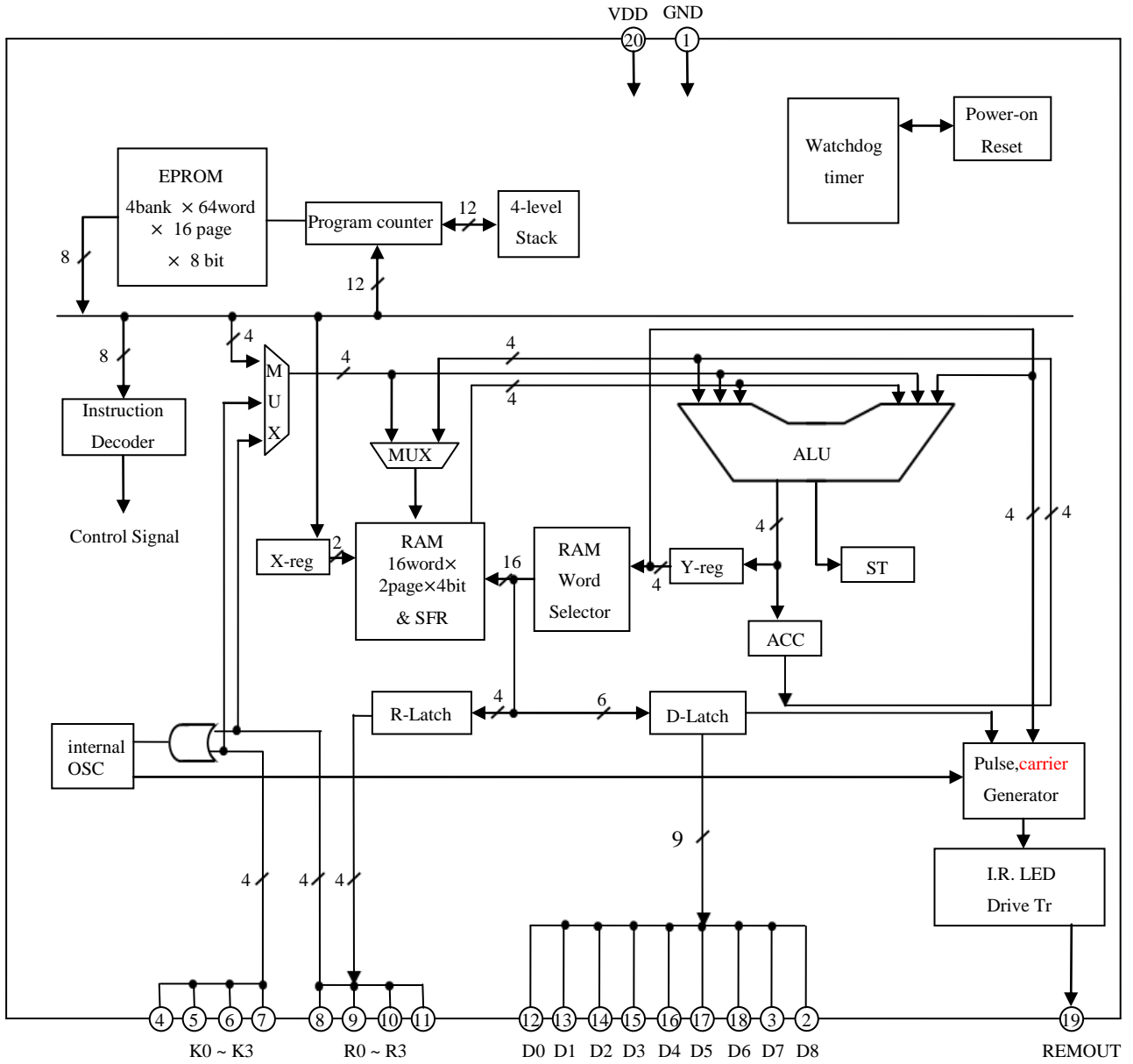

2.2 MC41P6104 (16 pin package)

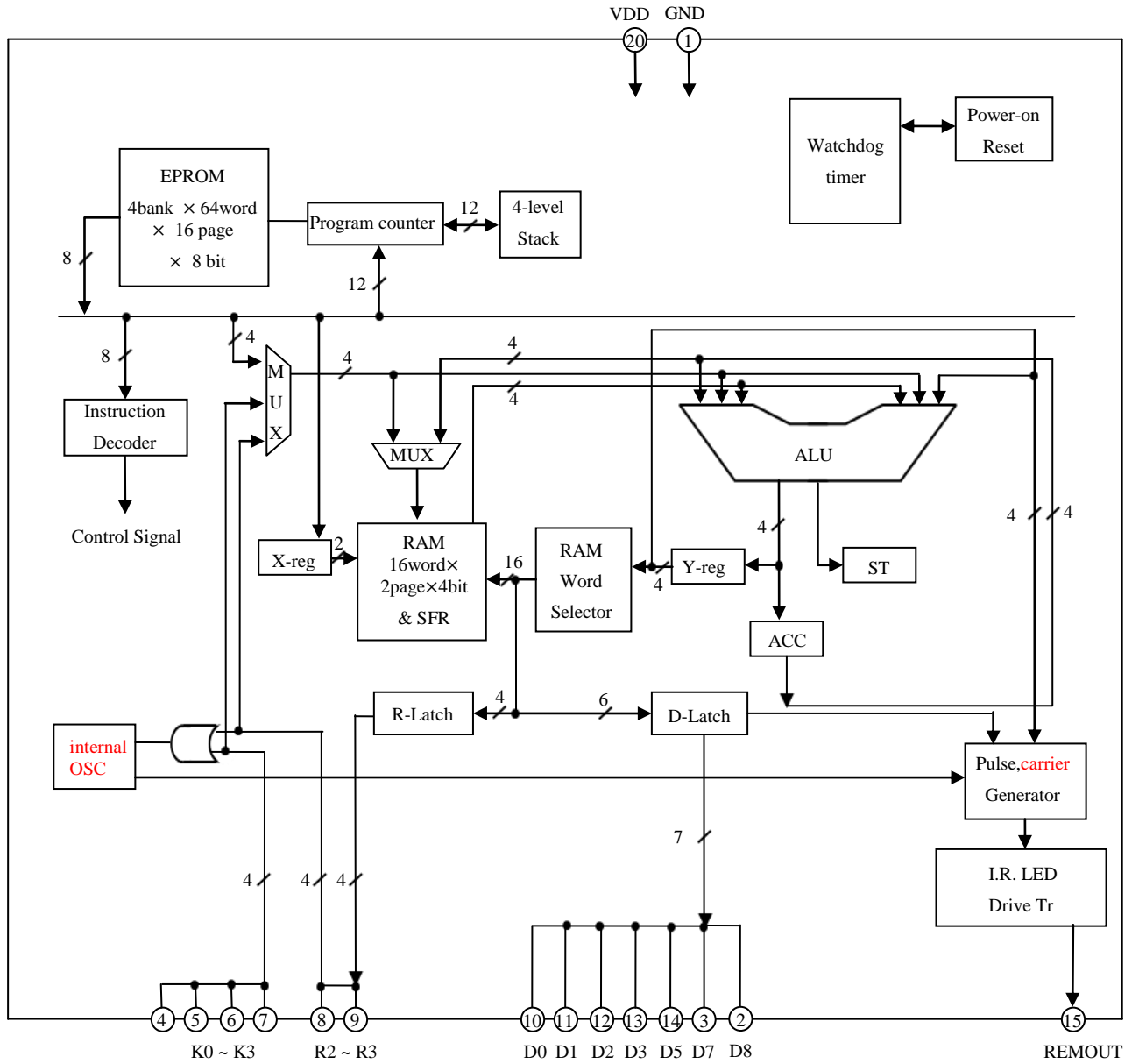

3. PIN ASSIGNMENT (top view)

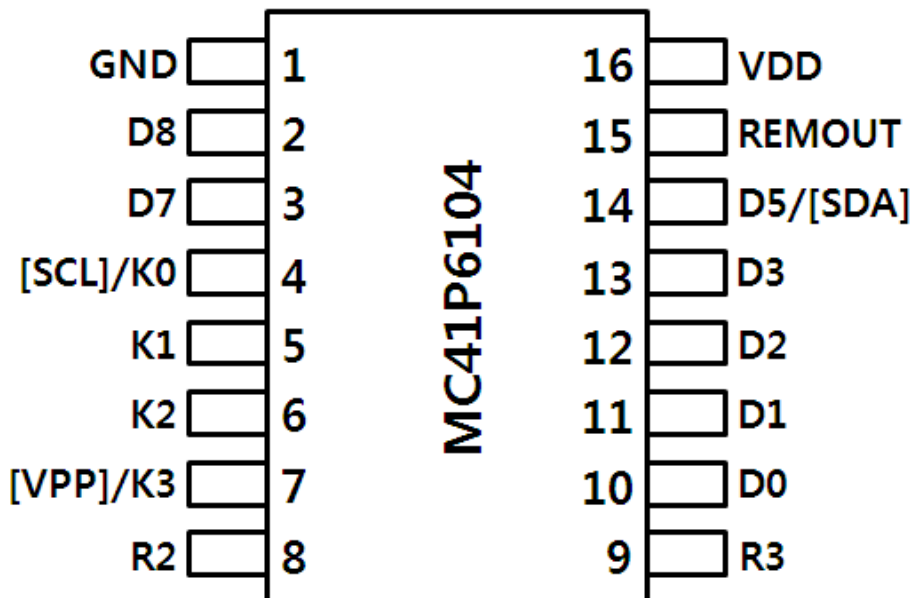
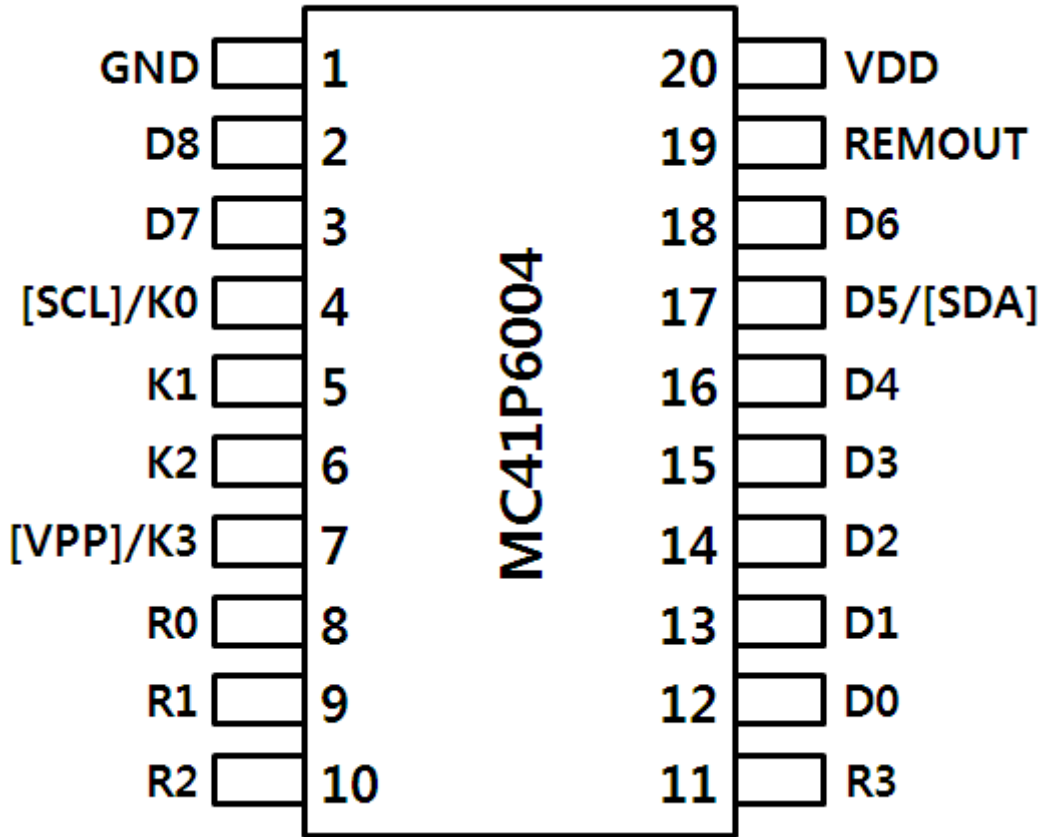

4. PACKAGE Dimension

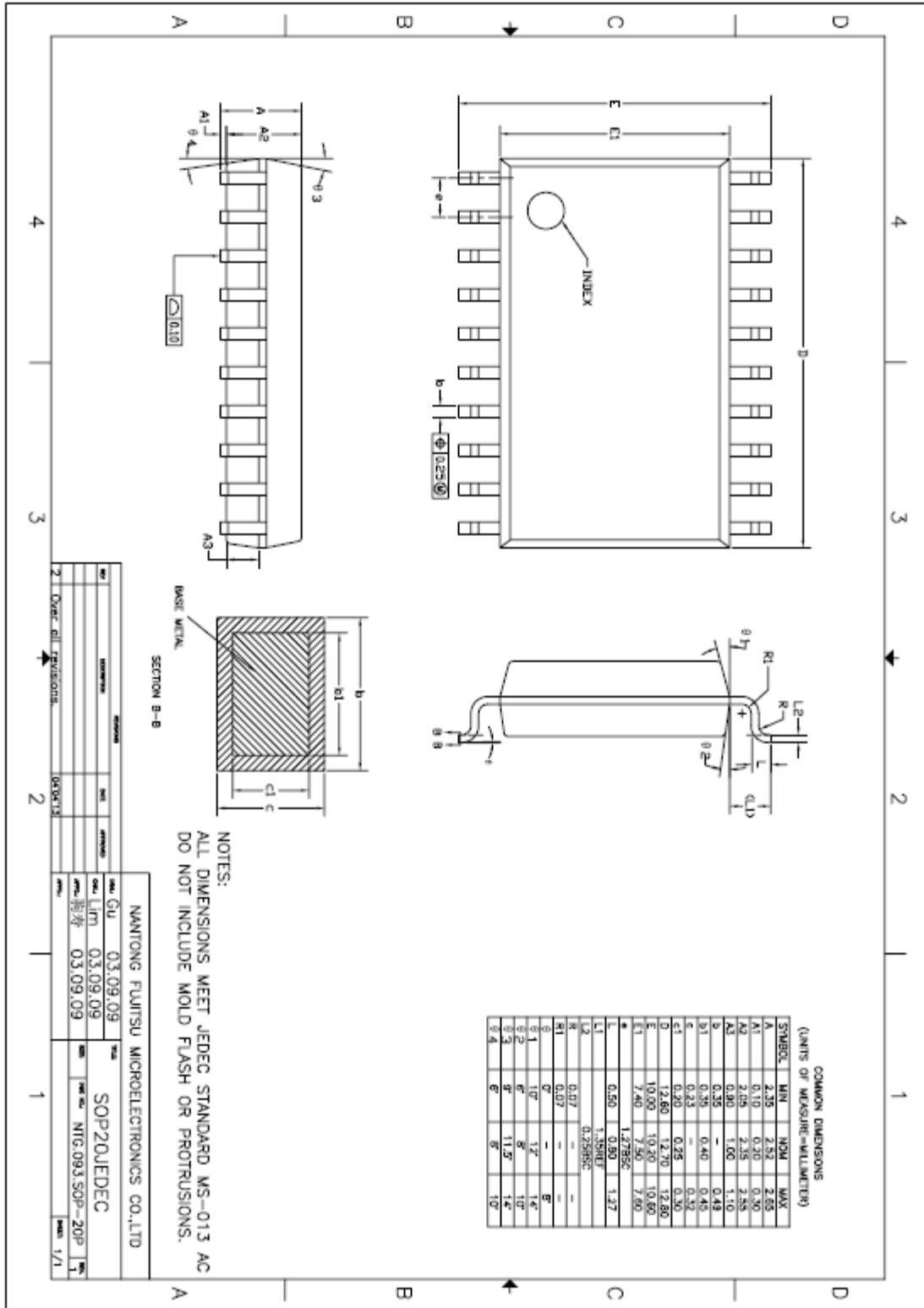

Fig 4-1 20SOP

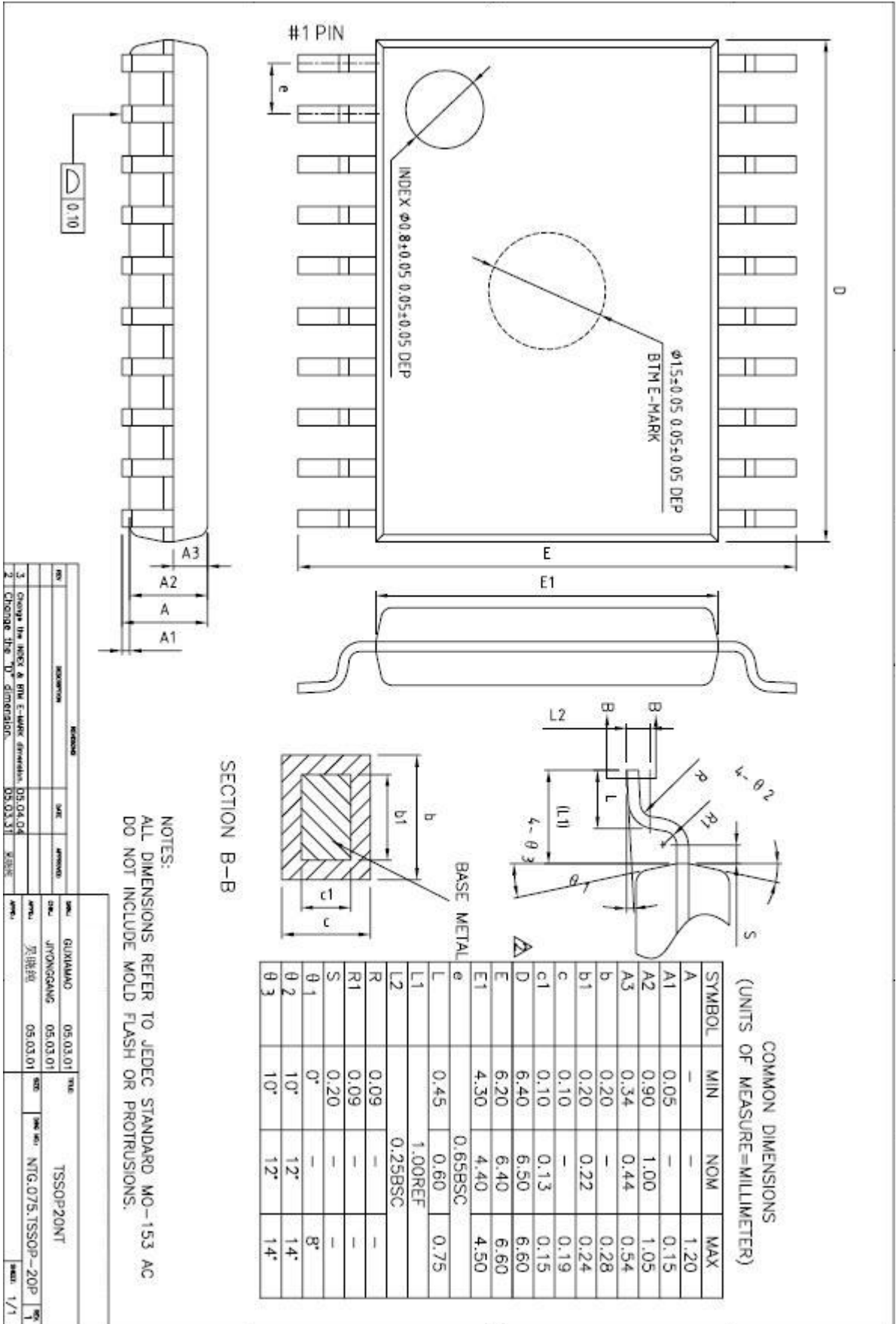

Fig 4-2 20TSSOP

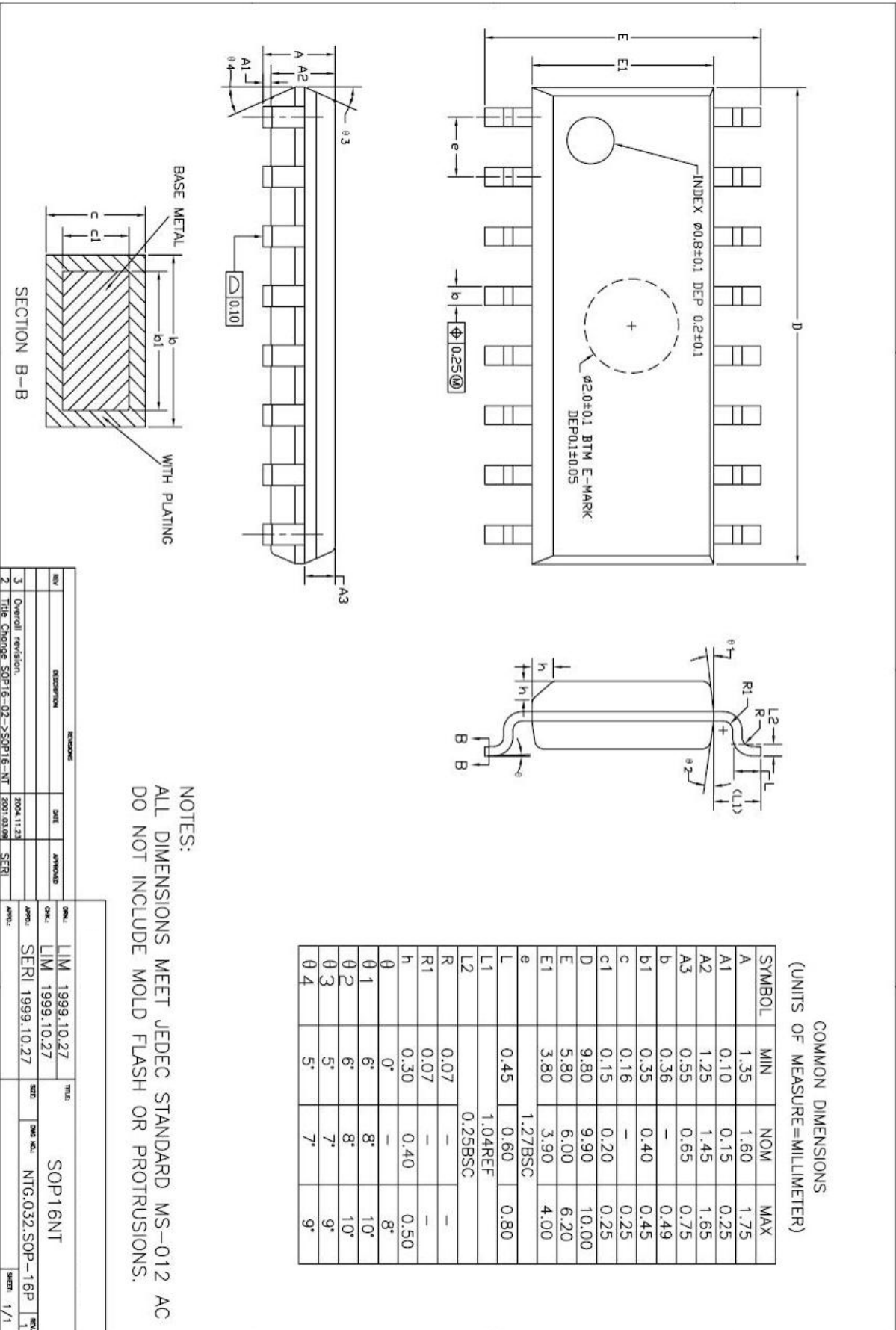

Fig 4-3 16SOPN

5. PIN FUNCTION

Pin	I/O	Function
VDD	-	Connected to 1.8~ 3.6V power supply
GND	-	Connected to 0V power supply.
K0 ~ K3	Input	4-bit input port with built in pull-up resistor. STOP mode is released by "L" input of each pin.
D0 ~ D8	Output	Each can be set and reset independently. The output is the structure of N-channel-open-drain. D0~D3 are "L" output at STOP MODE. D4 ~D8 keep the state before stop mode at STOP MODE.
R0 ~ R1	Input	2-bit input port with built in pull-up resistor. STOP mode is released by "L" input of each pin.
R2 ~ R3	I/O	2-bit I/O port with built in pull-up resistor. STOP mode is released by "L" input of each pin. Input mode is set only when each of them output "H". The output is in the form of C-MOS. In outputting, each can be set and reset independently(or at once.)
REMOUT	Output	High current output port for driving I.R.LED. The output is in the form N-channel open drain.

Note: D port pin mapping is

MC41P6004 (D0~D8), MC41P6104(D0~D3, D5, D7, D8)

6. PORT STRUCTURES

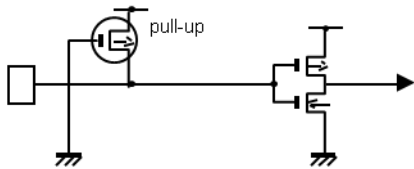
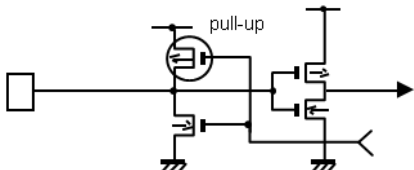
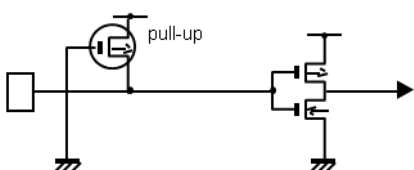
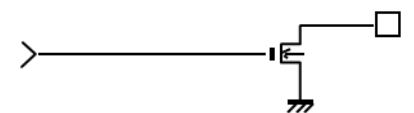
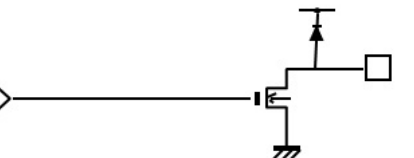
Pin	I/O	I/O circuit	Note
R0 ~ R1	I		- Built in MOS Tr for pull-up, about 140 kΩ.
R2 ~ R3	I/O		- CMOS output. - "H" output at reset. - Built in MOS Tr for pull-up, about 140 kΩ.
K0 ~ K3	I		- Built in MOS Tr for pull-up, about 140 kΩ.
D0 ~ D8	O		- Open drain output. - "L" output at reset. D0 ~ D3 : "L" at stop D4 ~ D8 : Keep status before stop
REMOUT	O		- Open drain output - Output Tr. Disable at Reset or stop.

7. ELECTRICAL CHARACTERISTICS

7.1 Absolute Maximum Ratings (Ta = 25°C)

Parameter	Symbol	Max. rating	Unit
Supply Voltage	V _{DD}	-0.3 ~ 5	V
Power dissipation	P _D	700 *	mV
Storage temperature range	T _{STQ}	-55 ~ 125	°C
Input voltage	V _{IN}	-0.3 ~ V _{DD} +0.3	V
Output voltage	V _{OUT}	-0.3 ~ V _{DD} +0.3	V

*Thermal derating above 25°C: 6mW per degree °C rise in temperature

7.2 Recommended Operating Conditions

Parameter	Symbol	Condition	Rating	Unit
Supply Voltage	V _{DD}	f _{osc} = 3.64MHZ	1.8 ~ 3.6	V
Operating frequency	f _{osc}	V _{DD} = 1.8V ~ 3.6V	3.6036 ~ 3.6764 (at Room Temp) 3.5854 ~ 3.6945 (at HOT/COLD Temp)	MHZ
Operating temperature	T _{OPR}	-	-20 ~ +70	°C

7.3 Electrical characteristics (Ta=25°C, V_{DD}= 3V)

Parameter	Symbol	Limits			Unit	Condition
		Min.	Typ.	Max.		
Input H current	I _{IH}	-	-	1	uA	VI=V _{DD}
K Pull-up Resistance	R _{PU1}	70	140	300	kΩ	VI=GND
R Pull-up Resistance	R _{PU2}	70	140	300	kΩ	VI=GND, Output off
Feedback Resistance	R _{FD}	0.3	1.0	3.0	MΩ	V _{OSC1} =GND, V _{OSC2} =VDD
K, R input H voltage	V _{IH1}	1.4	-	-	V	-
K, R input L voltage	V _{IL1}	-	-	0.6	V	-
D, R output L voltage	V _{OL2} *1	-	0.1	0.26	V	I _{OL} =3mA
REMOUT output L current	I _{OL4} *2	-	250 300	-	mA	V _{OL4} =0.3V V _{OL4} =0.52V
D, R output leakage current	I _{OLK2}	-	-	1	uA	V _{OUT} =V _{DD} , Output off
Low Voltage Reset voltage	V _{LVR}	-	1.5	-	V	
Current on STOP mode	I _{STP}	-	-	1	uA	At STOP mode
Operating Supply current	I _{DD2} *3	-	0.5	1.5	mA	f _{OSC} =4MHz

*1 Refer to Fig.7-1 < I_{OL1} vs. V_{OL1} Graph >

*2 Refer to Fig.7-2 < I_{OL4} vs. V_{OL4} Graph >

*3 I_{DD1}, I_{DD2}, is measured at RESET mode.

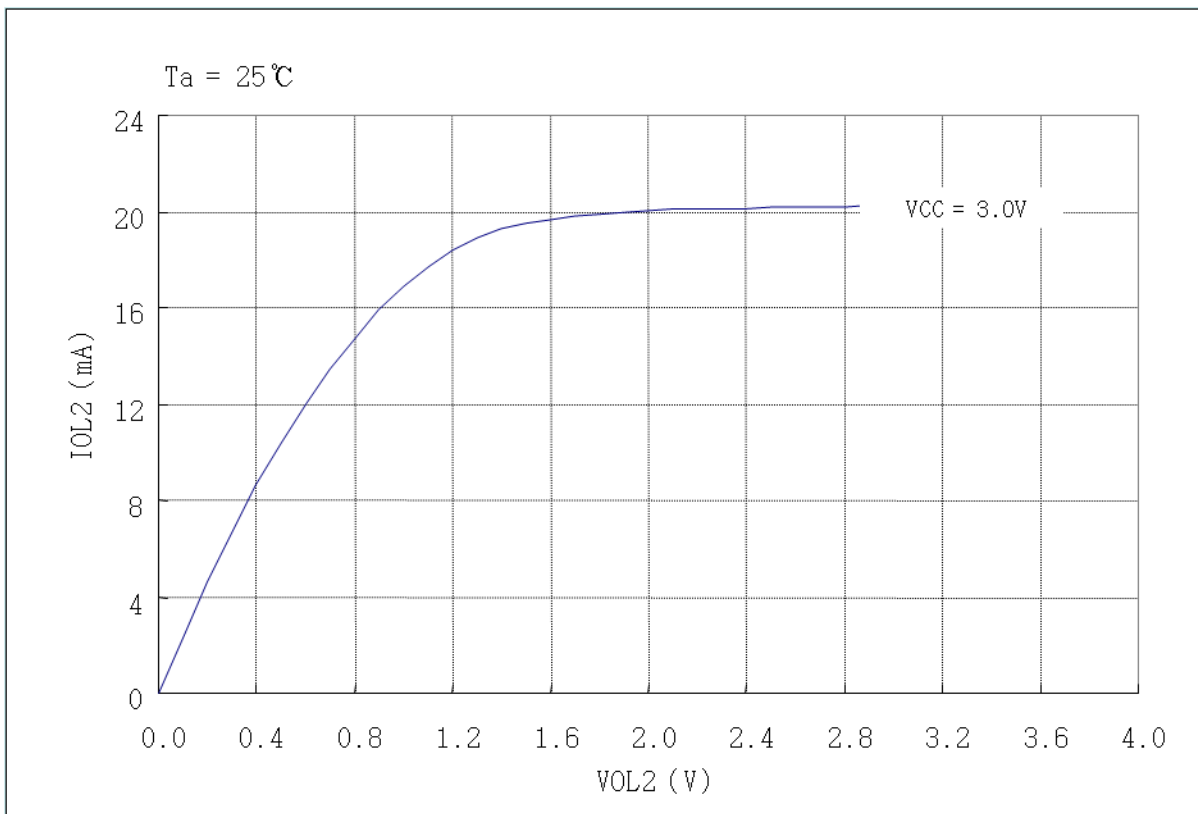

Fig 7-1. IOL2 vs. VOL2 Graph. (D, R Port)

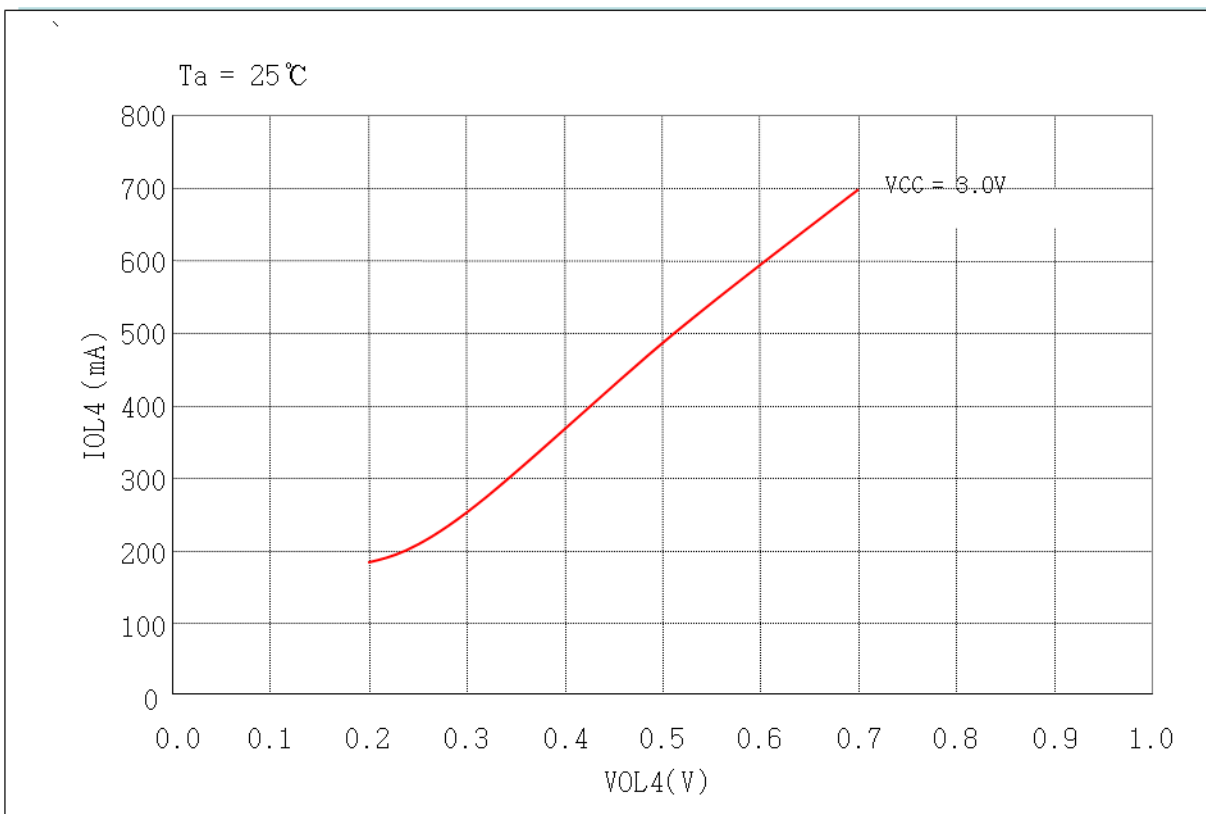

Fig 7-2. IOL4 vs. VOL4 Graph (REMOUT Port with built-in Transistor)

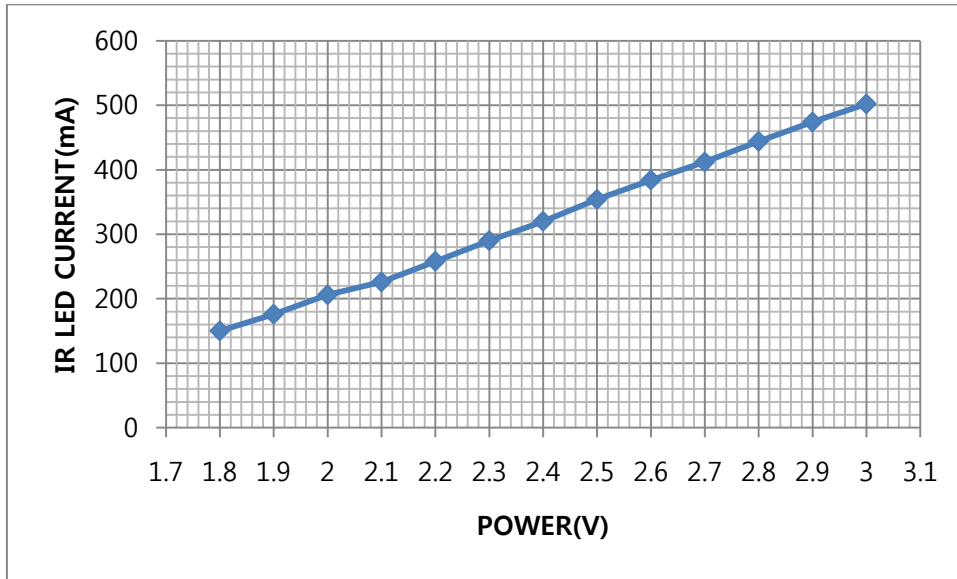

Fig 7-3. IR LED CURRENT by POWER (for reference data)

8. Architecture

8.1 Program Memory (EPROM)

The MC41P6x04 series can incorporate maximum 4,096 words (4 bank x 64 words x 16 page x 8bits) for program memory. Program counter PC (A0~A5), Page address register (A6~A9) and Bank address register (A10, A11) are used to address the whole area of program memory having an instruction (8bits) to be next executed.

The program memory consists of 64 words on each page, and thus each page can hold up to 64 steps of instructions.

The program memory is composed as shown below

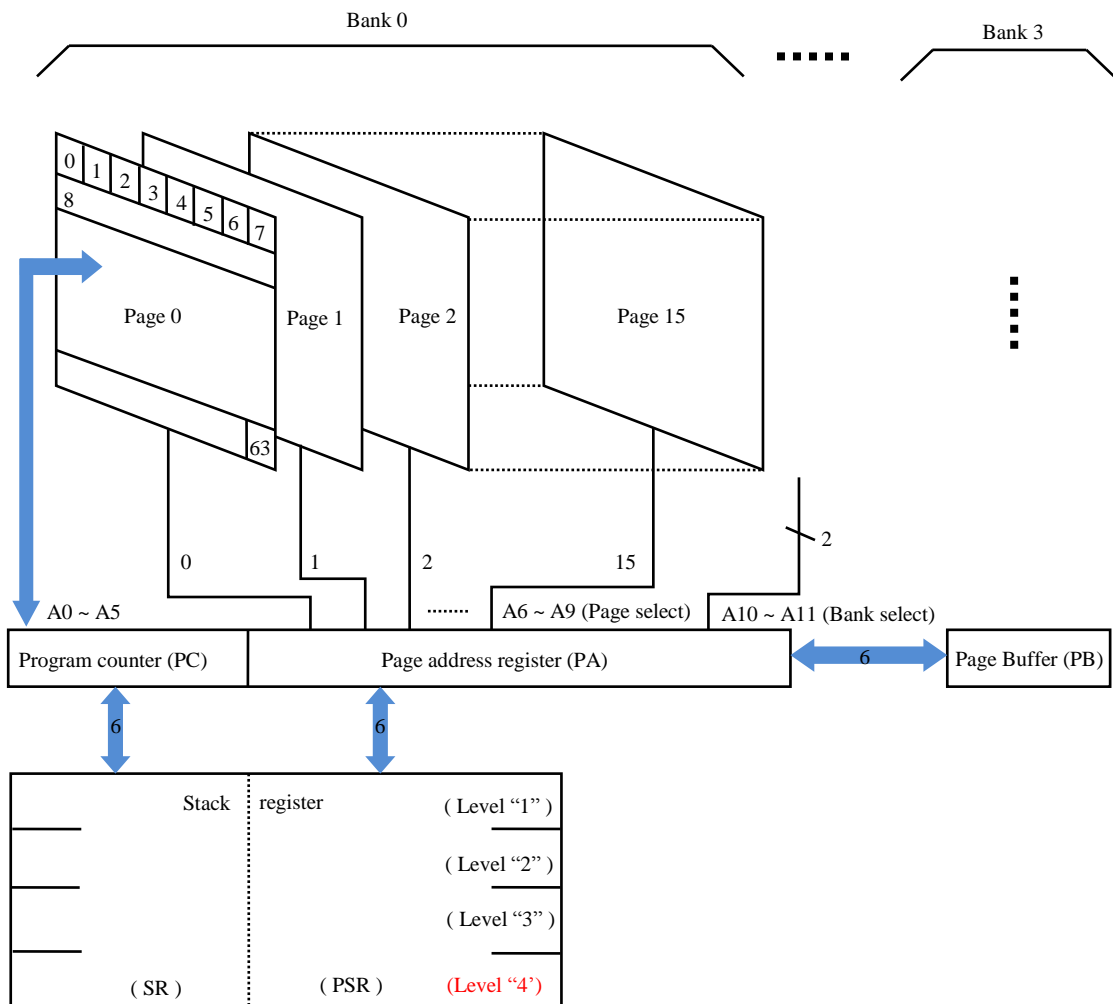

Fig 8-1 Configuration of Program Memory

8.2 EPROM Address Register

The following registers are used to address the EPROM.

- Page address register (PA)
Holds EPROM's page number (0~Fh) and bank address (0 ~ 3h)to be addressed.
- Page buffer register (PB)

Value of PB is loaded by an LPBI command when newly addressing a page. Then it is shifted into the PA when rightly executing a branch instruction (BR) and a subroutine call (CAL).

When addressing more than 1K, LPBI command must be used continuously. First LPBI value will be written at LSB 4bits, second is written at MSB 2bits.

	PA/PB	PC
MC40P5x01D	4 bit	6 bit
MC41P6x04	6 bit	6 bit

Fig 8-2 Compare MC40P5x01 with MC41P6x04

※ Example of command flow

Command	PA	PB	PC
⋮	XX_XXXX	XX_XXXX	pc
LPBI #7 (high 2bits 00, low 4bits #7)	XX_XXXX	00_0111	Next pc
LPBI #3 (high 2bits #3, low 4bits keep)	XX_XXXX	11_0111	Next pc
BR #2A	11_0111	11_0111	#2A

- Program counter (PC)
Available for addressing word on each page.
- Stack register (SR)
Stores returned-word address in the subroutine call mode.

(1) Page address register and page buffer register

Address one of pages #0 to #15 in the EPROM by the 4-bit binary counter. Unlike the program counter, the page address register is usually unchanged so that the program will repeat on the same page unless a page changing command is issued. To change the page address, take two steps such as (1) writing in the page buffer what page to jump (execution of LPBI) and (2) execution of BR or CAL, because instruction code is of eight bits so that page and word can not be specified at the same time.

In case a return instruction (RTN) is executed within the subroutine that has been called In the other page, the page address will be changed at the same time.

(2) Program counter

This 6-bit binary counter increments for each fetch to address a word in the currently addressed page having an instruction to be next executed. For easier programming, at turning on the power, the program counter is reset to the zero location. The PA is also set to "0". Then the program counter specifies the next EPROM address in random sequence. When BR, CAL or RTN instructions are decoded, the switches on each step are turned off not to update the address. Then, for BR or CAL, address data are taken in from the instruction operands (a0 to a5), or for RTN, and address is fetched from stack register No. 1.

(3) Stack register

This stack register provides **four** stages each for the program counter (6bits) and the page address register (4bits) so that subroutine nesting can be made on **four levels**.

8.3 Data memory(RAM) and Special function register(SFR)

Up to 32 nibbles (16 words x 2pages x 4bits) is incorporated for storing data at data memory. The whole data memory is indirectly specified by a data pointer (X, Y). Page number is specified by value of X register, and words in the page by 4 bits in Y-register. Data memory is composed in 16 nibbles/page. The SFR area is also specified by a data pointer (X, Y) where X register should be set to 3. Fig. 8-3 shows the configuration.

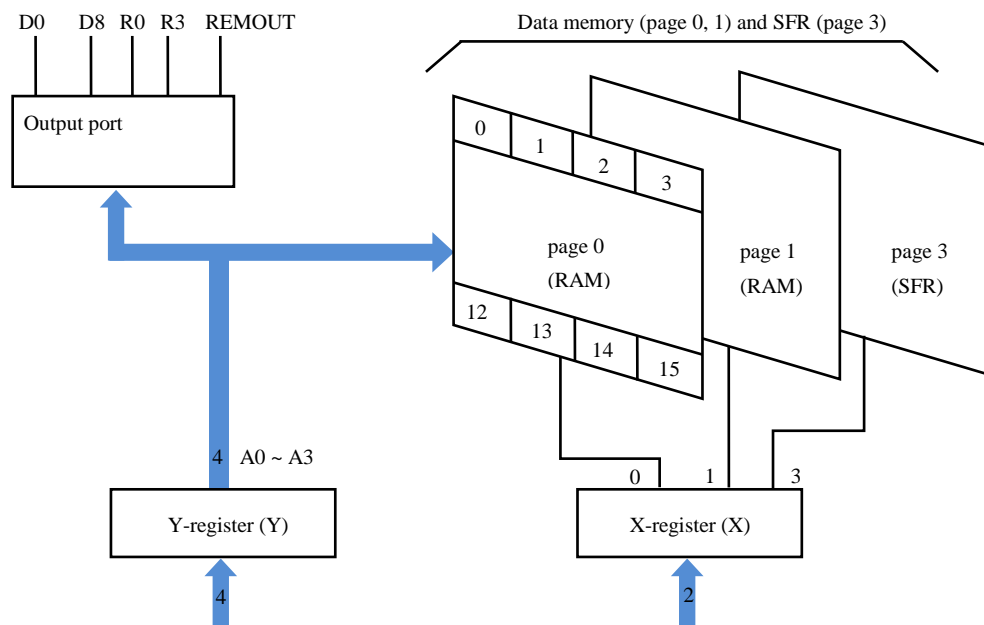

Fig 8-3 Configuration of Data Memory

8.4 X-register (X)

X-register is consist of 2bit(X1, X0), X is a data pointer of page in the RAM/SFR, and X1 is only used for selecting of D8 with value of Y-register for port access.

	X1 = 0 (X=0 or 1)	X1 = 1 (X=2 or 3)
Y = 0	D0	D8

Table 8-1 Mapping table between X and Y register for port access

8.5 Y-register (Y)

Y-register has 4 bits. It operates as a data pointer or a general-purpose register.

Y-register specifies and address (a0~a3) in a page of data memory and SFR, as well as it is used to specify an output port. Further it is used to specify a mode of carrier signal outputted from the REMOUT port. It can also be treated as a general-purpose register on a program.

8.6 Accumulator (Acc)

The 4-bit register for holding data and calculation results.

8.7 Arithmetic and Logic Unit (ALU)

In this unit, 4bits of adder/comparator are connected in parallel as it's main components and they are combined with status latch and status logic (flag.)

(1) Operation circuit (ALU)

The adder/comparator serves fundamentally for full addition and data comparison. It executes subtraction by making a complement by processing an inversed output of Acc (Acc +1)

(2) Status logic

This is to bring an ST, or flag to control the flow of a program. It occurs when a specified instruction is executed in three cases such as overflow or underflow in operation and two inputs unequal.

8.8 State Counter (SC)

A fundamental machine cycle timing chart is shown below. Every instruction is one byte length. Its execution time is the same. Execution of one instruction takes 48 clocks for fetch cycle and 48clocks for execute cycle (96 clocks in total).

Virtually these two cycles proceed simultaneously, and thus it is apparently completed in 48clocks (one machine cycle). Exceptionally BR, CAL and RTN instructions is normal execution time since they change an addressing sequentially. Therefore, the next instruction is prefetched so that its execution is completed within the fetch cycle.

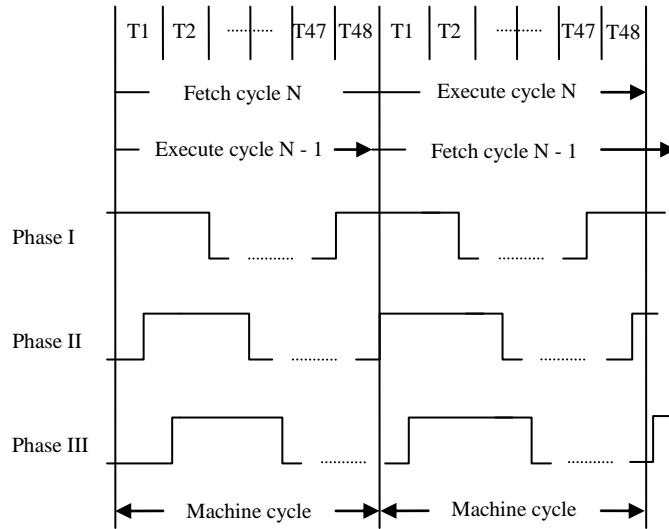
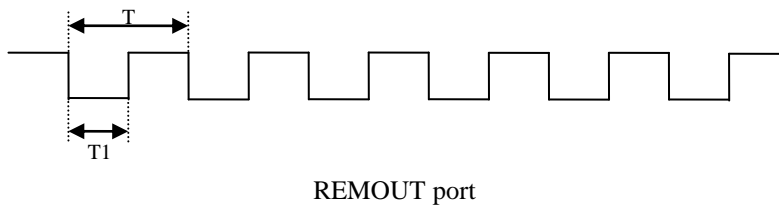

Fig 8-4 Fundamental timing chart

8.9 Pulse Generator

The following frequency and duty ratio are selected for carrier signal outputted from the REMOUT port depending on a PMR (Pulse Mode Register) value set in a program.



PMR	REMOUT signal	Carrier frequency ($f_{OSC} = 3.64\text{MHz}$)
0	$T=1/f_{PUL} = 96/ f_{OSC}, T1/T = 1/2$	37.92KHz
1	$T=1/f_{PUL} = 96/ f_{OSC}, T1/T = 1/3$	37.92KHz
2	$T=1/ f_{PUL} = 64/ f_{OSC}, T1/T = 1/2$	56.88KHz
3	$T=1/ f_{PUL} = 65/ f_{OSC}, T1/T = 22/65$	56.00KHz
4	$T=1/ f_{PUL} = 87/ f_{OSC}, T1/T = 1/3$	41.84KHz
5	No Carrier (same to inversion of D0~D8)	-
6	$T=1/ f_{PUL} = 91/ f_{OSC}, T1/T = 31/91$	40.00KHz
7	$T= 1/ f_{PUL} = 101/ f_{OSC}, T1/T = 34/101$	36.04KHz

*Default value is “0”

* f_{PUL} = Carrier Pulse frequency, f_{OSC} = Oscillation frequency

Table 8-3 PMR selection table

8.10 Carrier Generator

The following low or high pulse width are selected for carrier signal outputted from the REMOUT port depending on a carrier data High register(CdrH1:CdrH0) value and carrier data Low register (CdrL1:CdrL0) set in a program.

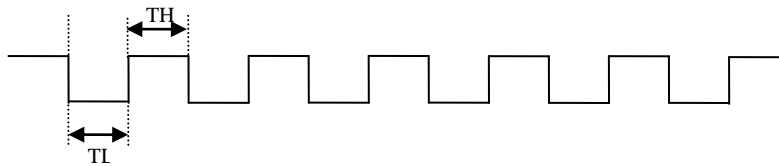

REMOUT port

REGISTER	ADDRESS	@RESET	Usable command	remark
CdrH1	Xreg = 3 Yreg = 4	Fh	LMA, LMAIY, LMIIY	Carrier Hi period, TH = {CdrH1,CdrH0} determination
CdrH0	Xreg = 3 Yreg = 5			
CdrL1	Xreg = 3 Yreg = 6			Carrier Low period, TL = {CdrL1,CdrL0} determination (first compare)
CdrL0	Xreg = 3 Yreg = 7			
Ccr	Xreg = 3 Yreg = 8	0		If Ccr[0] = 0, SELECT REMOUT by PMR data If Ccr[0] = 1, SELECT REMOUT by Carrier Data

Below table show a few remout port example by compare data reg value when osc is 3.64MHZ
 The number of pulse can be made as many kind as 65,536 (256 * 256) by carrier generator..

CDRH {CdrH1,CdrH0}	CDRL {CdrL1,CdrL0}	TH(us)	TL(us)	Total(us)	Freq.(KHZ)
0	0	0.2747	0.2747	0.5494	1820.17
0	1	0.27	0.55	0.82	1213.44
0	2	0.27	0.82	1.10	910.08
0	3	0.27	1.10	1.37	728.07
30	32	8.52	9.07	17.58	56.88
47	47	13.19	13.19	26.37	37.92
45	44	12.64	12.36	25.00	40.00
43	43	12.09	12.09	24.17	41.37
33	67	9.34	18.68	28.02	35.69
255	252	70.32	69.50	139.82	7.15
255	253	70.32	69.77	140.10	7.14
255	254	70.32	70.05	140.37	7.12
255	255	70.32	70.32	140.65	7.11

8.11 Reset Operation

MC41P6x04 series have three reset sources. One is a built-in Power-on reset circuit, Another is a built-in Low VDD Detection circuit, the other is the overflow of Watch Dog Timer (WDT). All reset operations are internal in the MC41P6x04.

8.11.1 Built-in Power On Reset Circuit

MC41P6x04 series has a built-in Power-on reset circuit consisting of an about 1 MΩ Resistor and a 3pF Capacitor. When the Power-on reset pulse occurs, system reset signal is latched and WDT is cleared. After the overflow time of WDT(2^{13} x System clock time), system reset signal is released.

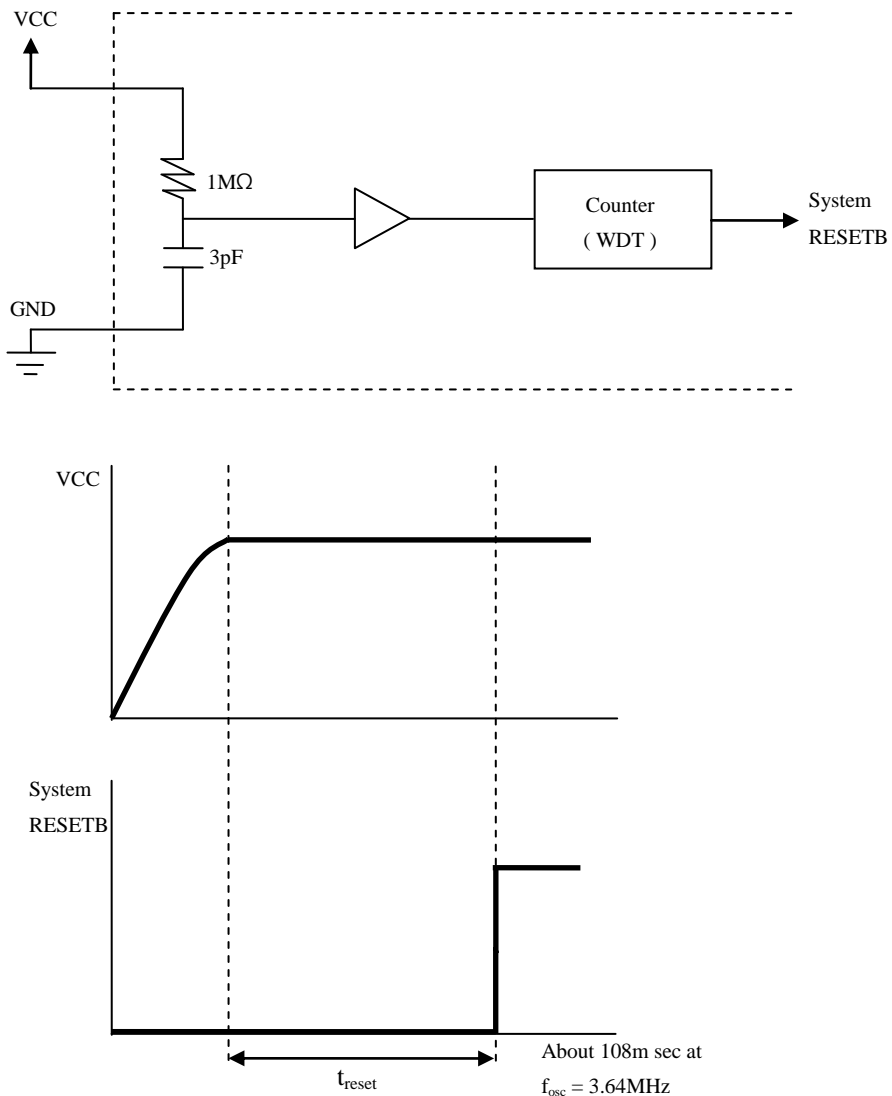

Fig 8-6 Power –On Reset Circuit and Timing Chart

8.11.2 Built-in Low VDD Reset Circuit

MC41P6x04 series have a Low VDD detection circuit.

If VDD become Reset Voltage of Low VDD Detection circuit at a active status, system reset occur and WDT is cleared.

After VDD is increased upper Reset Voltage again, WDT is re-counted and if WDT is overflowed, system reset is released.

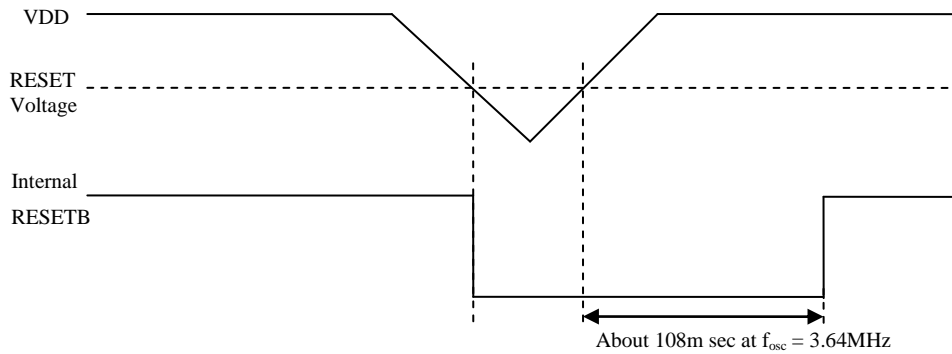

Fig 8-7 Low Voltage Detection Timing Chart

8.11.3 Watch Dog Timer (WDT)

Watch dog timer is organized binary of 14 steps. The signal of f_{osc} /48 or f_{osc}/12 cycle comes in the first step of WDT after WDT reset. If this counter was overflowed, reset signal automatically come out so that internal circuit is initialized.

The overflow time is $8 \times 6 \times 2^{13} / f_{osc}$ (108.026ms at f_{osc} = 3.64MHz)

Normally, the binary counter must be reset before the overflow by using reset instruction (WDTR), Power-on reset pulse or Low VDD detection pulse.

* It is constantly reset in STOP mode. When STOP is released, counting is restarted. (Refer to STOP operation)

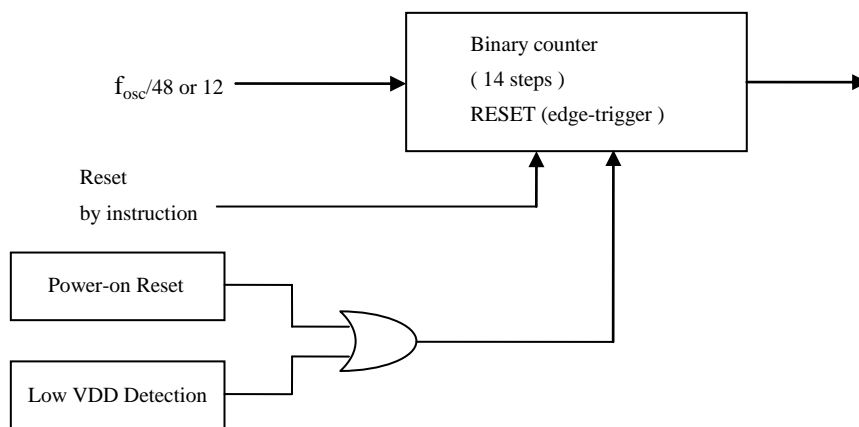

8.12 STOP Operation

Stop mode can be achieved by STOP instructions.

In stop mode

1. Oscillator is stopped, the operating current is low.
2. Watch dog timer is reset, D0~D3 output are "L", and REMOUT output are "H"(High-Z).
3. Part of output pin other than WDT, D0~D3 and REMOUT output have a value before come into stop mode.

Stop mode is released when one of K or R input is going to "L".

1. State of D0~D7 output and REMOUT output is return to state of before stop mode is achieved.
2. After 1,024 x 8 enable clocks for stable oscillating, First instruction start to operate.
3. In return to normal operation, WDT is counted from zero again.

But, at executing stop instruction, if one of K or R input is chosen to "L", stop instruction is same to NOP (No Operation) instruction.

Value of X-reg	Value of Y-reg	Operation
0 or 1	0 ~ 7	S0 : D(Y) ← 1, R0 : D(Y) ← 0
0 or 1	8	REMOUT port repeats "H" and "L" in pulse frequency. (When PMR = 5, it is fixed at "H") S0 : REMOUT ← 0 R0 : REMOUT(PMR) ← 1 (High-Z)
0 or 1	9	S0 : D0 ~ D8 ← 1 (High-Z) R0 : D0 ~ D8 ← 0
0 or 1	A ~ D	S0 : R(Y-Ah) ← 1 R0 : R(Y-Ah) ← 0
0 or 1	E	S0 : R0 ~ R3 ← 1 R0 : R0 ~ R3 ← 0
0 or 1	F	S0 : D0 ~ D8 ← 1, R0 ~ R3 ← 1 R0 : D0 ~ D8 ← 0, R0 ~ R3 ← 0
2 or 3	0	S0 : D(8) ← 1 R0 : D(8) ← 0

9. Instruction

9.1 Instruction Table

The MC41P6x04 series provides the following 43 basic instructions.

	Category	Mnemonic	Function	ST* ¹
1	Register to Register	LAY	$A \leftarrow Y$	S
2		LYA	$Y \leftarrow A$	S
3		LAZ	$A \leftarrow 0$	S
4	RAM to Register	LMA	$M(X, Y) \leftarrow A$	S
5		LMAIY	$M(X, Y) \leftarrow A, Y \leftarrow Y + 1$	S
6		LYM	$Y \leftarrow M(X, Y)$	S
7		LAM	$A \leftarrow M(X, Y)$	S
8		XMA	$A \leftrightarrow M(X, Y)$	S
9	Immediate	LYI i	$Y \leftarrow i$	S
10		LMIIY i	$M(X, Y) \leftarrow i, Y \leftarrow Y + 1,$	S
11		LXI n	$X \leftarrow n$	S
12	RAM Bit Manipulation	SEM n	$M(n) \leftarrow 1$	S
13		REM n	$M(n) \leftarrow 0$	S
14		TM n	TEST $M(n) \leftarrow 1$	E
15	ROM Address	BR a	if ST = 1 then Branch	S
16		CAL a	if ST = 1 then Subroutine call	S
17		RTN	Return from Subroutine	S
18		LDWIY	$M(X, Y) \leftarrow \text{LSB}[\text{index3}, \text{index2}, \text{index1}]$ $M(X, Y+1) \leftarrow \text{MSB}[\text{index3}, \text{index2}, \text{index1}]$	S
19		LPBI i	$PB \leftarrow i$	S
20	Arithmetic	AM	$A \leftarrow A + M(X, Y)$	C
21		SM	$A \leftarrow M(X, Y) - A$	B

22	Arithmetic	IM	$A \leftarrow M(X, Y) + 1$	C
23		DM	$A \leftarrow M(X, Y) - 1$	B
24		IA	$A \leftarrow A + 1$	S
25		IY	$Y \leftarrow Y + 1$	C
26		DA	$A \leftarrow A - 1$	B
27		DY	$Y \leftarrow Y - 1$	B
28		EORM	$A \leftarrow A \oplus M(X, Y)$	S
29		NEGA	$A \leftarrow \bar{A} + 1$	Z
30		Comparison	ALEM	TEST $A \leq M(X, Y)$
31	ALEI i		TEST $A \leq i$	E
32	MNEZ		TEST $M(X, Y) \neq 0$	N
33	YNEA		TEST $Y \neq A$	N
33	YNEI i		TEST $Y \neq i$	N
34	KNEZ		TEST $K \neq 0$	N
35	Input/ Output	LAK	$A \leftarrow K$	S
36		LAR	$A \leftarrow R$	S
37		SO	Output(Y) $\leftarrow 1^{*2}$	S
38		RO	Output(Y) $\leftarrow 0^{*2}$	S
39	Control	WDTR	Watch Dog Timer Reset	S
40		STOP	Stop operation	S
41		LPY	$PMR \leftarrow Y$	S
42		NOP	No operation	S

Note) i = 0~f, n = 0~3, a = 6bit PC Address

*1 Column ST indicates conditions for changing status. Symbols have the following meanings

- S: On executing an instruction, status is unconditionally set.
- C: Status is only set when carry or borrow has occurred in operation.
- B: Status is only set when borrow has not occurred in operation.
- E: Status is only set when equality is found in comparison.
- N: Status is only set when equality is not found in comparison.
- Z: Status is only set when the result is zero.

*2 Operation is settled by a value of Y-register..

9.2 DETAILS OF INSTRUCTION SYSTEM

All 43 basic instructions of the MC41P6X04 Series are one by one described in detail below.

Description Form.

Each instruction is headlined with its mnemonic symbol according to the instructions table given earlier. Then, for quick reference, it is described with basic items as shown below. After that, detailed comment follows.

*Items :

- Naming : Full spelling of mnemonic symbol
- Status : Check of status function
- Format : Categorized into I to IV
- Operand : Omitted for Format I
- Function

(1) LAY

Naming : Load Accumulator from Y-Register

Status : Set

Format : I

Function : $A \leftarrow Y$

<Comment> Data of four bits in the Y-register is unconditionally transferred to the accumulator. Data in the Y-register is left unchanged.

(2) LYA

Naming : Load Y-register from Accumulator

Status : Set

Format : I

Function : $Y \leftarrow A$

<Comment> Load Y-register from Accumulator

(3) LAZ

Naming : Clear Accumulator

Status : Set

Format : I

Function : $A \leftarrow 0$

<Comment> Data in the accumulator is unconditionally reset to zero.

(4) LMA

Naming : Load Memory from Accumulator

Status : Set

Format : I

Function : $M(X,Y) \leftarrow A$

<Comment> Data of four bits from the accumulator is stored in the RAM location addressed by the X-register and Y-register. Such data is left unchanged.

(5) LMAIY

Naming : Load Memory from Accumulator and Increment Y-Register

Status : Set

Format : I

Function : $M(X,Y) \leftarrow A, Y \leftarrow Y+1$

<Comment> Data of four bits from the accumulator is stored in the RAM location addressed by the X register and Y-register. Such data is left unchanged.

(6) LYM

Naming : Load Y-Register form Memory

Status : Set

Format : I

Function : $Y \leftarrow M(X,Y)$

<Comment> Data from the RAM location addressed by the X-register and Y-register is loaded into the Y-register. Data in the memory is left unchanged.

(7) LAM

Naming : Load Accumulator from Memory

Status : Set

Format : I

Function : $A \leftarrow M(X,Y)$

<Comment> Data from the RAM location addressed by the X-register and Y-register is loaded into the Y-register. Data in the memory is left unchanged.

(8) XMA

Naming : Exchanged Memory and Accumulator

Status : Set

Format : I

Function : $M(X,Y) \leftrightarrow A$

<Comment> Data from the memory addressed by X-register and Y-register is exchanged with data from the accumulator. For example, this instruction is useful to fetch a memory word into the accumulator for operation and store current data from the accumulator into the RAM. The accumulator can be restored by another XMA instruction.

(9) LYI i

Naming : Load Y-Register from Immediate

Status : Set

Format : III

Operand : Constant $0 \leq i \leq 15$

Function : $Y \leftarrow i$

<Purpose> To load a constant in Y-register. It is typically used to specify Y-register in a particular RAM word address, to specify the address of a selected output line, to set Y-register for specifying a carrier signal outputted from OUT port, and to initialize Y-register for loop control. The accumulator can be restored by another XMA instruction.

<Comment> Data of four bits from operand of instruction is transferred to the Y-register.

(10) LMIY i

Naming : Load Memory from Immediate and Increment Y-Register

Status : Set

Format : III

Operand : Constant $0 \leq i \leq 15$

Function : $M(X,Y) \leftarrow i, \quad Y \leftarrow Y + 1$

<Comment> Data of four bits from operand of instruction is stored into the RAM location addressed by the X-register and Y-register. Then data in the Y-register is incremented by one.

(11) LXI n

Naming : Load X-Register from Immediate

Status : Set

Format : II

Operand : X file address $0 \leq n \leq 3$

Function : $X \leftarrow n$

<Comment> A constant is loaded in X-register. It is used to set X-register in an index of desired RAM page. Operand of 1 bit of command is loaded in X-register.

(12) SEM n

Naming : Set Memory Bit

Status : Set

Format : II

Operand : Bit address $0 \leq n \leq 3$

Function : $M(X,Y,n) \leftarrow 1$

<Comment> Depending on the selection in operand of operand, one of four bits is set as logic 1 in the RAM memory addressed in accordance with the data of the X-register and Y-register.

(13) REM n

Naming : Reset Memory Bit

Status : Set

Format : II

Operand : Bit address $0 \leq n \leq 3$

Function : $M(X,Y,n) \leftarrow 0$

<Comment> Depending on the selection in operand of operand, one of four bits is set as logic 0 in the RAM memory addressed in accordance with the data of the X-register and Y-register.

(14) TM n

Naming : Test Memory Bit

Status : Comparison results to status

Format : II

Operand : Bit address $0 \leq n \leq 3$

Function : $M(X,Y,n) = 1 ?$

$ST \leftarrow 1$ when $M(X,Y,n)=1$, $ST \leftarrow 0$ when $M(X,Y,n)=0$

<Purpose> A test is made to find if the selected memory bit is logic. 1 Status is set depending on the result.

(15) BR a

Naming : Branch on status 1

Status : Conditional depending on the status

Format : IV

Operand : Branch address a (Addr)

Function : When $ST = 1$, $PA \leftarrow PB$, $PC \leftarrow a(\text{Addr})$

When $ST = 0$, $PC \leftarrow PC + 1$, $ST \leftarrow 1$

Note : PC indicates the next address in a fixed sequence that is actually pseudo-random count.

<Purpose> For some programs, normal sequential program execution can be change. A branch is conditionally implemented depending on the status of results obtained by executing the previous instruction.

<Comment>

- Branch instruction is always conditional depending on the status.
 - a. If the status is reset (logic 0), a branch instruction is not rightly executed but the next instruction of the sequence is executed.
 - b. If the status is set (logic 1), a branch instruction is executed as follows.
- Branch is available in two types - short and long. The former is for addressing in the current page and the latter for addressing in the other page. Which type of branch to execute is decided according to the PB register. To execute a long branch, data of the PB register should in advance be modified to a desired page address through the LPBI instruction.

(18) LDWIY

Naming : Load Word from Memory addressed by {INDEX3, INDEX2, INDEX1} register

Status : Set

Format : I

Function : $M(X,Y) \leftarrow \text{LSB 4-Bit of } [@\{\text{Index3,Index2,Index1}\}]$

$M(X,Y+1) \leftarrow \text{MSB 4-Bit of } [@\{\text{Index3,Index2,Index1}\}]$

<Purpose> Data transfer from Memory to Memory.

<Comment> The memory location addressed by the X and Y register is loaded lower four bit of memory location addressed by {index3, index2, index1} and

The memory location addressed by the X and Y+1 register is loaded higher four bit of memory location addressed by {index3, index2, index1}

REGISTER	ADDRESS	@RESET	Usable command	remark
INDEX3	Xreg = 3 Yreg = a	0	All Memory Access command	
INDEX2	Xreg = 3 Yreg = b			
INDEX1	Xreg = 3 Yreg = c			

(19) LPBI i

Naming : Load Page Buffer Register from Immediate

Status : Set

Format : III

Operand : ROM page address $0 \leq i \leq 15$

Function : $PB \leftarrow i$

<Purpose> A new ROM page address is loaded into the page buffer register (PB). This loading is necessary for a long branch or call instruction.

<Comment> The PB register is loaded together with three bits from 4 bit operand.

(24) IA

Naming : Increment Accumulator

Status : Set

Format : I

Function : $A \leftarrow A+1$

<Comment> Data of the accumulator is incremented by one. Results are returned to the accumulator. A carry is not allowed to have effect upon the status.

(25) IY

Naming : Increment Y-Register and Status 1 on Carry

Status : Carry to status

Format : I

Function : $Y \leftarrow Y + 1$ $ST \leftarrow 1$ (when $Y = 15$) $ST \leftarrow 0$ (when $Y < 15$)

<Comment> Data of the Y-register is incremented by one and results are returned to the Y-register. Carry data as results is transferred to the status. When the total is more than 15, the status is set.

(26) DA

Naming : Decrement Accumulator and Status 1 on Borrow

Status : Carry to status

Format : I

Function : $A \leftarrow A - 1$ $ST \leftarrow 1$ (when $A \geq 1$) $ST \leftarrow 0$ (when $A = 0$)

<Comment> Data of the accumulator is decremented by one. As a result (by addition of Fh), if a borrow is caused, the status is reset to "0" by logic. If the data is more than one, no borrow occurs and thus the status is set to "1".

(27) DY

Naming : Decrement Y-Register and Status 1 on Not Borrow

Status : Carry to status

Format : I

Function : $Y \leftarrow Y - 1$ $ST \leftarrow 1$ (when $Y \geq 1$) $ST \leftarrow 0$ (when $Y = 0$)

<Purpose> Data of the Y-register is decremented by one.

<Comment> Data of the Y-register is decremented by one by addition of minus 1 (Fh). Carry data as results is transferred to the status. When the results is equal to 15, the status is set to indicate that no borrow has not occurred.

(28) EORM

Naming : Exclusive or Memory and Accumulator

Status : Set

Format : I

Function : $A \leftarrow M(X,Y) \oplus A$

<Comment> Data of the accumulator is, through a Exclusive OR, subtracted from the memory word addressed by X and Y-register. Results are stored into the accumulator.

(29) NEGA

Naming : Negate Accumulator and Status 1 on Zero

Status : Carry to status

Format : I

Function : $A \leftarrow \bar{A} + 1$ $ST \leftarrow 1(\text{when } A = 0)$
 $ST \leftarrow 0(\text{when } A \neq 0)$

<Purpose> The 2`s complement of a word in the accumulator is obtained.

<Comment> The 2`s complement in the accumulator is calculated by adding one to the 1`s complement in the accumulator. Results are stored into the accumulator. Carry data is transferred to the status. When data of the accumulator is zero, a carry is caused to set the status to "1".

(30) ALEM

Naming : Accumulator Less Equal Memory

Status : Carry to status

Format : I

Function : $A \leq M(X,Y)$ $ST \leftarrow 1(\text{when } A \leq M(X,Y))$
 $ST \leftarrow 0(\text{when } A > M(X,Y))$

<Comment> Data of the accumulator is, through a complemental addition, subtracted from data in the memory location addressed by the X and Y-register. Carry data obtained is transferred to the status. When the status is "1", it indicates that the data of the accumulator is less than or equal to the data of the memory word. Neither of those data is not changed.

(31) ALEI

Naming : Accumulator Less Equal Immediate

Status : Carry to status

Format : III

Operand : Constant $0 \leq i \leq 15$ Function : $A \leq i$ $ST \leftarrow 1(\text{when } A \leq i)$
 $ST \leftarrow 0(\text{when } A > i)$

<Purpose> Data of the accumulator and the constant are arithmetically compared.

<Comment> Data of the accumulator is, through a complemental addition, subtracted from the constant that exists in 4bit operand. Carry data obtained is transferred to the status. The status is set when the accumulator value is less than or equal to the constant. Data of the accumulator is left unchanged.

(36) LAK

Naming : Load Accumulator from K
 Status : Set
 Format : I
 Function : $A \leftarrow K$
 <Comment> Data on K are transferred to the accumulator

(37) LAR

Naming : Load Accumulator from R
 Status : Set
 Format : I
 Function : $A \leftarrow R$
 <Comment> Data on R are transferred to the accumulator

(38) SO

Naming : Set Output Register Latch
 Status : Set
 Format : I
 Function : $D(Y) \leftarrow 1 \quad 0 \leq Y \leq 7$
 $REMOUT \leftarrow 0 \quad Y = 8$
 $D0\sim D8 \leftarrow 1 \text{ (High-Z)} \quad Y = 9$
 $R(Y) \leftarrow 1 \quad Ah \leq Y \leq Dh$
 $R \leftarrow 1 \quad Y = Eh$
 $D0\sim D8, R \leftarrow 1 \quad Y = Fh$

<Purpose> A single D output line is set to logic 1, if data of Y-register is between 0 to 7. Carrier frequency comes out from REMOUT port, if data of Y-register is 8.
 All D output line is set to logic 1, if data of Y-register is 9. It is no operation, if data of Y-register between 10 to 15.

When Y is between Ah and Dh, one of R output lines is set at logic 1.

When Y is Eh, the output of R is set at logic 1.

When Y is Fh, the output D0~D8 and R are set at logic 1.

<Comment> Data of Y-register is between 0 to 7, selects appropriate D output.
 Data of Y-register is 8, selects REMOUT port.
 Data of Y-register is 9, selects all D port.
 Data in Y-register, when between Ah and Dh, selects an appropriate R output (R0~R3).
 Data in Y-register, when it is Eh, selects all of R0~R3.
 Data in Y-register, when it is Fh, selects all of D0~D8 and R0~R3.

(39) RO

Naming : Reset Output Register Latch

Status : Set

Format : I

Function : $D(Y) \leftarrow 0 \quad 0 \leq Y \leq 7$
 $REMOUT(PMR=5) \leftarrow 1(\text{High-Z}) \quad Y = 8$
 $D0\sim D8 \leftarrow 0 \quad Y = 9$
 $R(Y) \leftarrow 0 \quad Ah \leq Y \leq Dh$
 $R \leftarrow 0 \quad Y = Eh$
 $D0\sim D8, R \leftarrow 0 \quad Y = Fh$

<Purpose> A single D output line is set to logic 0, if data of Y-register is between 0 to 9.
 REMOUT port is set to logic 1(High-Z), if data of Y-register is 9.
 All D output line is set to logic 0, if data of Y-register is 9.
 When Y is between Ah and Dh, one of R output lines is set at logic 0.
 When Y is Eh, the output of R is set at logic 0
 When Y is Fh, the output D0~D8 and R are set at logic 1.

<Comment> Data of Y-register is between 0 to 7, selects appropriate D output.
 Data of Y-register is 8, selects REMOUT port.
 Data of Y-register is 9, selects D port.
 Data in Y-register, when between Ah and Dh, selects an appropriate R output (R0~R3).
 Data in Y-register, when it is Eh, selects all of R0~R3.
 Data in Y-register, when it is Fh, selects all of D0~D8 and R0~R3.

(40) WDTR

Naming : Watch Dog Timer Reset

Status : Set

Format : I

Function : Reset Watch Dog Timer (WDT)

<Purpose> Normally, you should reset this counter before overflowed counter for dc watch dog timer.
 this instruction controls this reset signal.

(41) STOP

Naming : STOP

Status : Set

Format : I

Function : Operate the stop function

<Purpose> Stopped oscillator, and little current.
 (See 1-12 page, STOP function.)

(42) LPY

Naming : Pulse Mode Set

Status : Set

Format : I

Function : PMR ← Y

<Comment> Selects a pulse signal outputted from REMOUT port.

(43) NOP

Naming : No Operation

Status : Set

Format : I

Function : No operation

9.3 Assembler Macro

(44) CALL a (2 or 3byte) : Long_call Macro

Page call within Bank (2bytes instruction) :

LPBI i ; i = low_page address(4bits), PB3~0(low_page address) <-- i
 CAL a ; see you "CAL" instruction.

Page call out of Bank (3bytes instruction) :

LPBI i ; i = low_page address(4bits), PB3~0(low_page address) <-- i
 LPBI i ; i = high_page address(2bits), PB5~4(high_page address) <-- i
 CAL a ; see you "CAL" instruction.

(45) BL a (2 or 3byte) : Long_branch Macro

Page branch within Bank (2bytes instruction) :

LPBI i ; i = low_page address(4bits), PB0~3(low_page address) <-- i
 BR a ; see you "BR" instruction.

Page branch out of Bank (3bytes instruction) :

LPBI i ; i = low_page address(4bits), PB3~0(low_page address) <-- i
 LPBI i ; i = high_page address(2bits), PB5~4(high_page address) <-- i
 BR a ; see you "BR" instruction.

(46) ACALL a (3byte) : Absolute call Macro

Full-range ROM address call (3bytes instruction) :

LPBI i ; i = low_page address(4bits), PB3~0(low_page address) <-- i
 LPBI i ; i = high_page address(2bits), PB5~4(high_page address) <-- i
 CAL a ; see you "CAL" instruction.

(47) ABL a (3byte) : Absolute branch Macro

Full-range ROM address branch (3bytes instruction) :

LPBI i ; i = low_page address(4bits), PB3~0(low_page address) <-- i
 LPBI i ; i = high_page address(2bits), PB5~4(high_page address) <-- i
 BR a ; see you "BR" instruction.

* a(address) : 6bits, i (low_page address) : 4bits, i (high_page address) : 2bits
 Bank(16pages unit)

10. SPGM (Serial Program)

Summary of Protocol

※ The I²C Bus Protocol

The I²C bus protocol is a method of communication. It physically consists of 2 active wires. The active wires, called SCL and SDA, are both bi-directional. SCL is the Serial Clock line. It is used to synchronize all data transfers over the I²C bus. and SDA is the Serial Data line. The SCL & SDA lines are connected to all devices on the I²C bus.

• **necessary pins (5pins)**

- Serial Data (SDA) : D5
- Serial Clock (SCL) : K0
- Programming Power(VPP) : K3
- VDD
- VSS

OPTION PROGRAM / READ DATA Format

-	-	-	CLKSEL	Offset3	Offset2	Offset1	Offset0
---	---	---	--------	---------	---------	---------	---------

CLKSEL : change the Main Clock fosc/48, fosc/12 (default fosc/48) . If you select fosc/12, instruction cycle is 4 times faster than fosc/48, but Carrier Frequency isn't affected.

“0” : fosc/12

“1” : fosc/48

OFFSET : at normal mode, change the ROM address

-	-	-	-	LOCK 3	LOCK 2	LOCK 1	LOCK 0
---	---	---	---	--------	--------	--------	--------

- LOCK : when program is read by PGM-PLUS, Data Protection

ID 7	ID 6	ID 5	ID 4	ID 3	ID 2	ID 1	ID 0
------	------	------	------	------	------	------	------

- ID7 – ID0 : it can be treated as User ID.

MC41P6004 ID: 1000 1111b

MC41P6104 ID: 1010 1111b

※ For protection the written program code, in other words it can not be read, you have to clear the Option bit to “0”, and for this, you have to write the Option Register to 1111_1110b. In this time, ID7 – ID0 keep the existing value without any effect

4K MTP (Multi Time Programming)

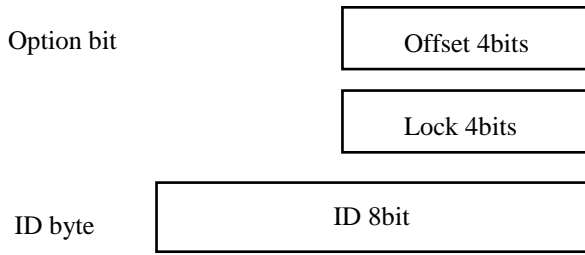

Lock 4bits : block address (Block 0 ~ Block 3)
 when Lock is set, 00H is read
 (0 = Lock , 1 = Unlock)

Offset bit's flow
 (after write, it will be updated)

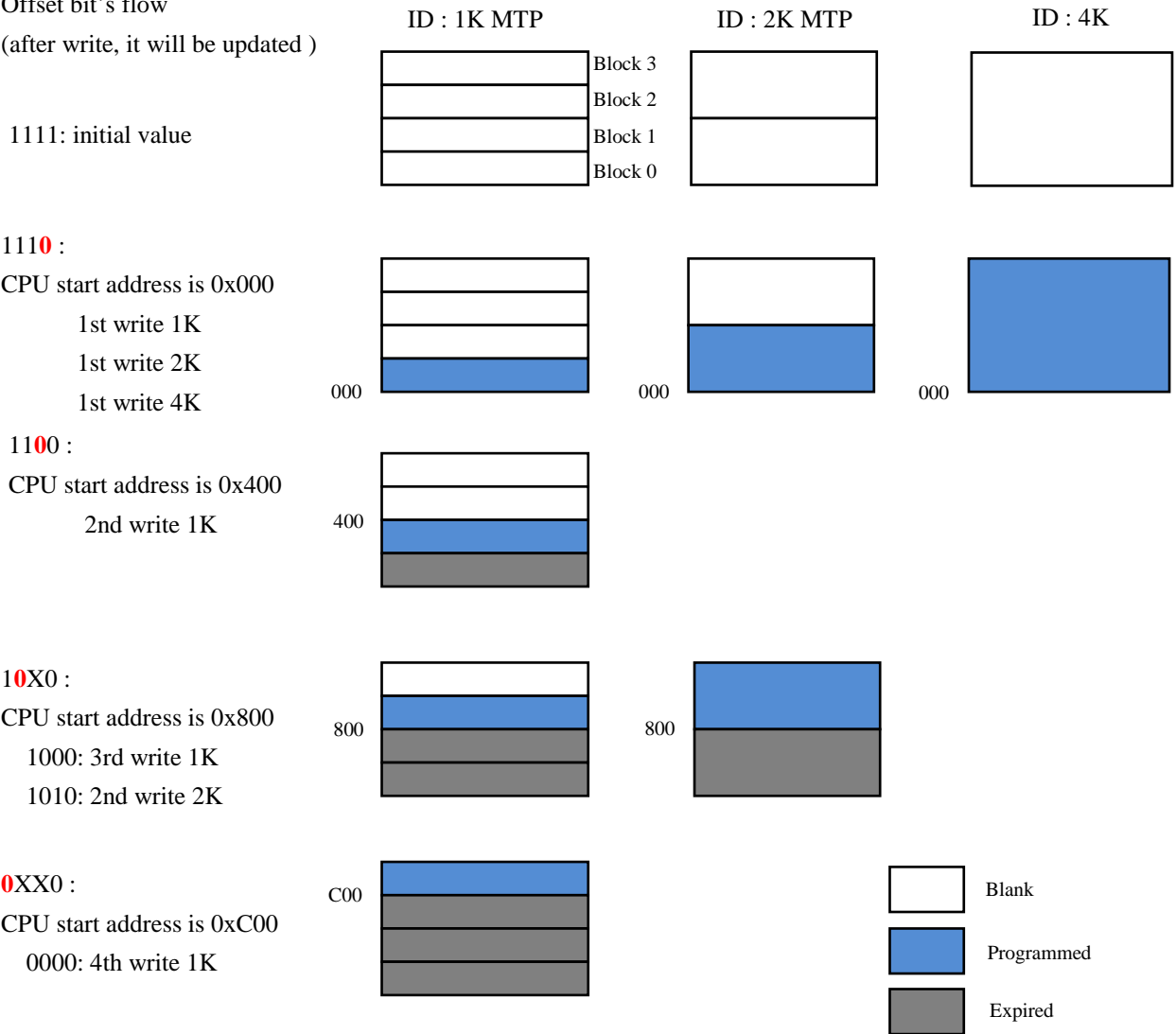

• Case of Available MTP

Case	1K	1K	1K	1K	Available
1K*4					O
2K*2					O
4K*1					O
1K, 1K, 2K					X
1K, 2K					O
1K, 2K, 1K					O
2K, 1K, 1K					O

	1 st PGM
	2 nd PGM
	3 rd PGM
	4 th PGM
	Expired

11. APPLICATION CIRCUIT DIAGRAM

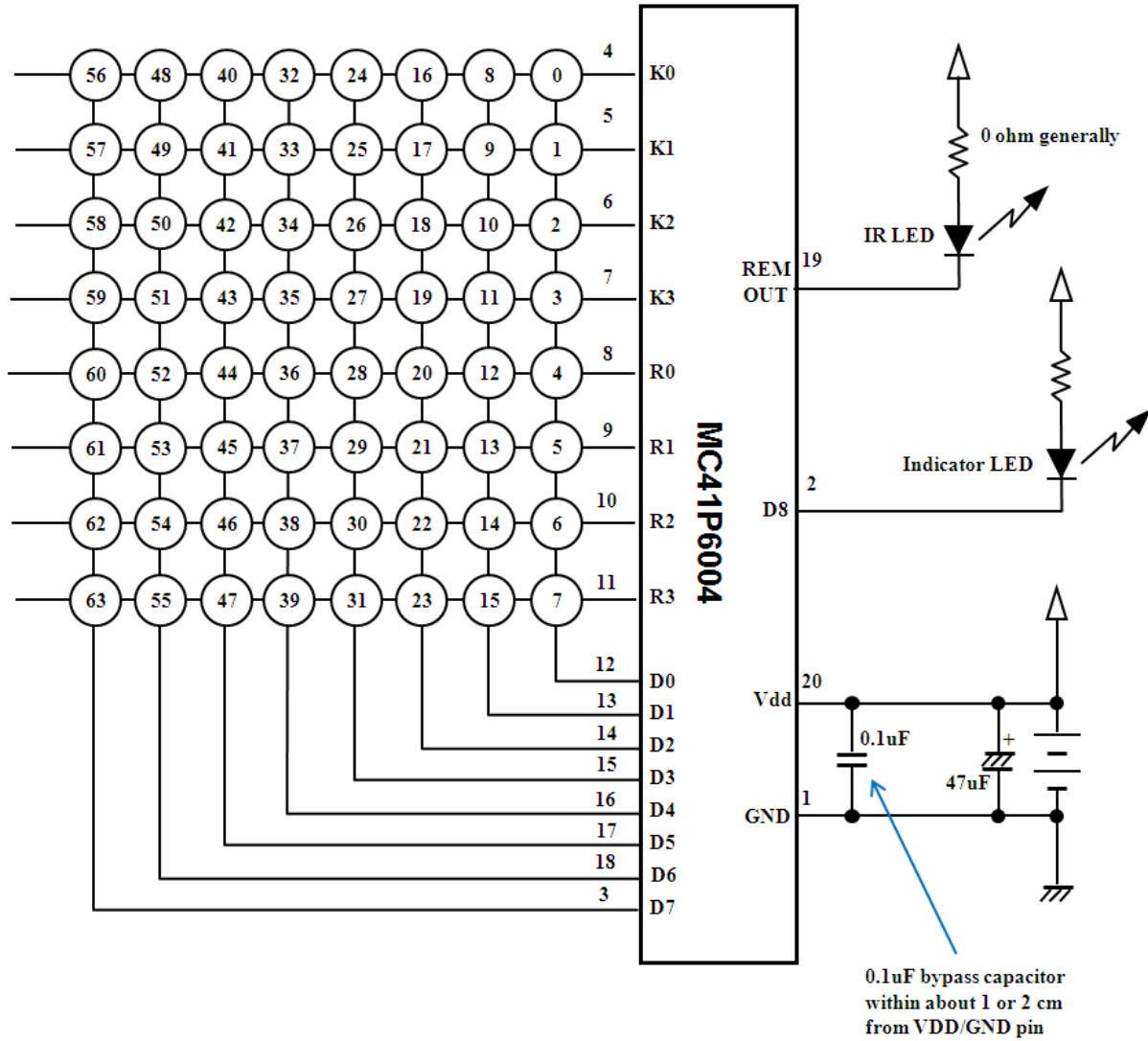

Fig 11-1. MC41P6004 with Built-in TR Circuit Diagram

*NOTE

1. Power stabilization capacitor and bypass capacitor :

is recommended to be placed as close to VDD/GND pins as possible for better MCU operation.

2. IR LED serial resistance :

Coin cell batteries generally causes large VDD level drop during IR LED emission due to low current capacity and high internal resistance. Therefore, users have to optimize the circuit conditions by adjusting IR LED serial resistance to reduce IR LED current and to avoid early occurrence of LVD reset and to meet aiming IR reaching range and longer battery lifetime.

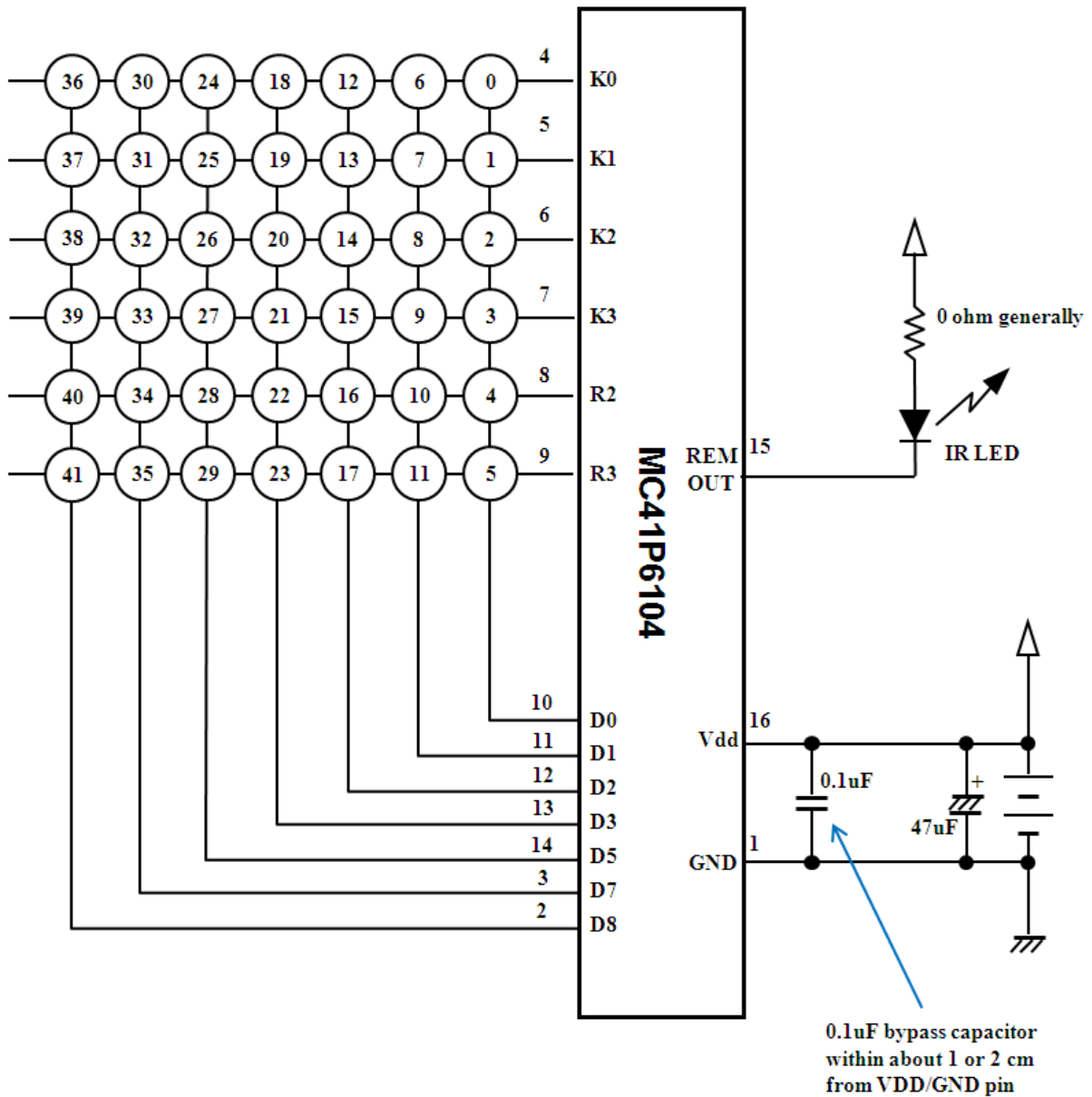

Fig 11-2. MC41P6104 with Built-in TR Circuit Diagram

***NOTE**

1. Power stabilization capacitor and bypass capacitor :

is recommended to be placed as close to VDD/GND pins as possible for better MCU operation.

2. IR LED serial resistance :

Coin cell batteries generally causes large VDD level drop during IR LED emission due to low current capacity and high internal resistance. Therefore, users have to optimize the circuit conditions by adjusting IR LED serial resistance to reduce IR LED current and to avoid early occurrence of LVD reset and to meet aiming IR reaching range and longer battery lifetime.