

## Product Preview

# MC68153 Bus Interrupter Module

The bipolar LSI MC68153 Bus interrupter interfaces a microcomputer system bus to multiple slave devices requiring interrupt capabilities. It handles up to 4 independent sources of interrupt requests and is fully programmable.

- VERSAbus™/VMEbus™ Compatible
- MC68000 Compatible
- Handles 4 Independent Interrupt Sources
- 8 Programmable Read/Write Registers
- Programmable Interrupt Request Levels
- Programmable Interrupt Vectors
- Supports Interrupt Acknowledge Daisy Chain
- Control Registers Contain Flag Bits
- Single +5.0 Volt Supply
- Total Power Dissipation = 1.0 W Typical
- Temperature Range of 0°C to 70°C
- Chip Access Time = 200 ns Typical with 16 MHz Clock
- 40-Pin Dual-In-Line Packages

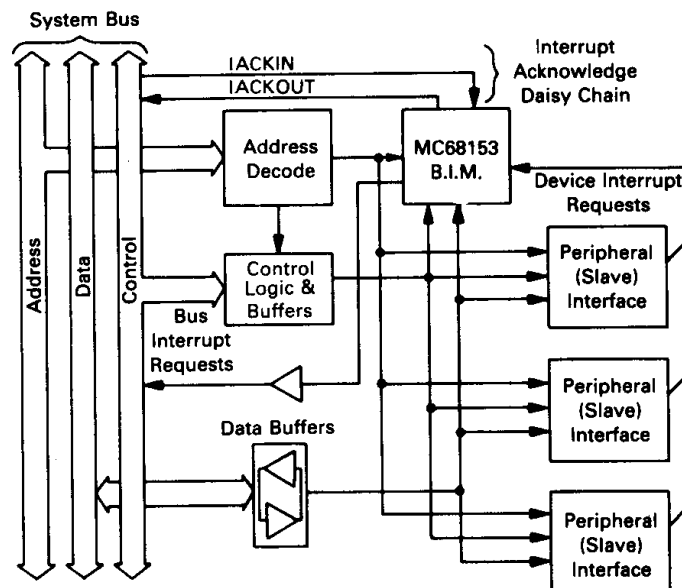

FIGURE 1 — BLOCK DIAGRAM

VERSAbus and VMEbus are trademarks of Motorola Inc.

This document contains information on a new product. Specifications and information herein are subject to change without notice.



MC68153

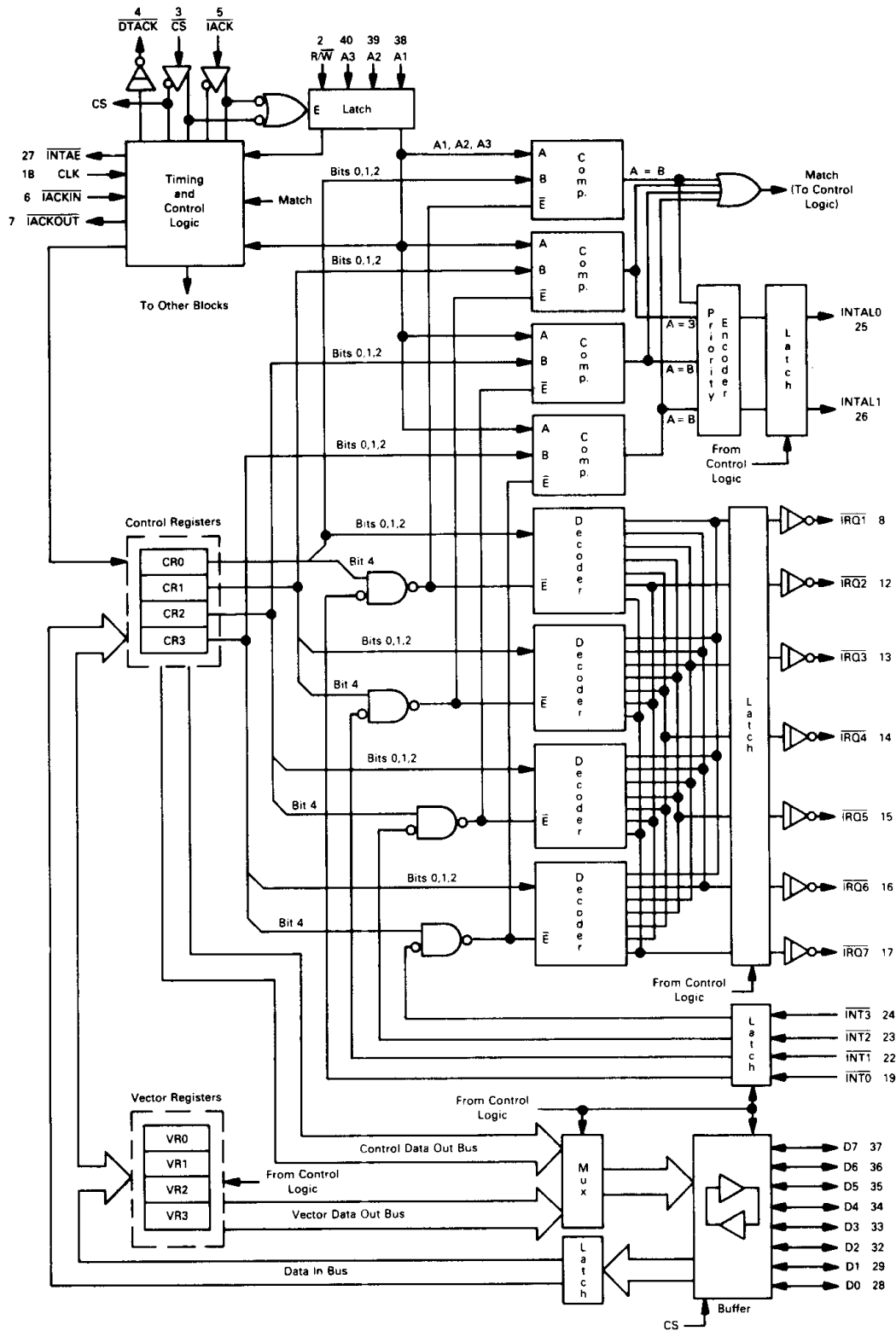

FIGURE 2 — MC68153 FUNCTIONAL BLOCK DIAGRAM

8

**ABSOLUTE MAXIMUM RATINGS** (Beyond which useful life may be impaired.)

Parameter	Symbol	Value	Unit
Supply Voltage	$V_{CC}$	-0.5 to +7.0	V
Input Voltage	$V_{in}$	-0.5 to +7.0	V
Input Current	$I_{in}$	-30 to +5.0	mA
Output Voltage	$V_{out}$	-0.5 to +5.5	V
Output Current	$I_{OL}$	Twice Rated $I_{OL}$	mA
Storage Temperature	$T_{stg}$	-65 to +140	°C
Junction Operating Temperature	$T_J$	-55 to +140	°C

**BURN-IN LIMITS:** A maximum  $T_J$  of +175°C may be used for periods not to exceed 250 hours.

**DC ELECTRICAL SPECIFICATIONS** ( $V_{CC} = 5.0 \text{ V} \pm 5\%$ ,  $T_A = 0^\circ\text{C}$  to  $70^\circ\text{C}$ )

Parameter	Symbol	Min	Max	Unit	Test Conditions
High Level Input Voltage	$V_{IH}$	2.0	—	V	
Low Level Input Voltage	$V_{IL}$	—	0.8	V	
Input Clamp Voltage	$V_{IK}$	—	-1.5	V	$V_{CC} = \text{MIN}, I_{IN} = -18 \text{ mA}$
High Level Output Voltage <sup>(1)</sup>	$V_{OH}$	2.7	—	V	$V_{CC} = \text{MIN}, I_{OH} = -400 \mu\text{A}$
Low Level Output Voltage	$V_{OL}$	—	0.4	V	$V_{CC} = \text{MIN}, I_{OL} = 8.0 \text{ mA}$
Output Short Circuit Current <sup>(2)</sup>	$I_{OS}$	-15	-130	mA	$V_{CC} = \text{MAX}, V_{OUT} = 0 \text{ V}$
High Level Input Current	$I_{IH}$	—	20	$\mu\text{A}$	$V_{CC} = \text{MAX}, V_{IN} = 2.7 \text{ V}$
Low Level Input Current	$I_{IL}$	—	-0.4	mA	$V_{CC} = \text{MAX}, V_{IN} = 0.4 \text{ V}$
Supply Current	$I_{CC}$	225	385	mA	$V_{CC} = \text{MAX}$
Output Off Current (High)	$I_{OZH}$	—	20	$\mu\text{A}$	$V_{CC} = \text{MAX}, V_{OUT} = 2.4 \text{ V}$
Output Off Current (Low)	$I_{OZL}$	—	-20	$\mu\text{A}$	$V_{CC} = \text{MAX}, V_{OUT} = 0.4 \text{ V}$

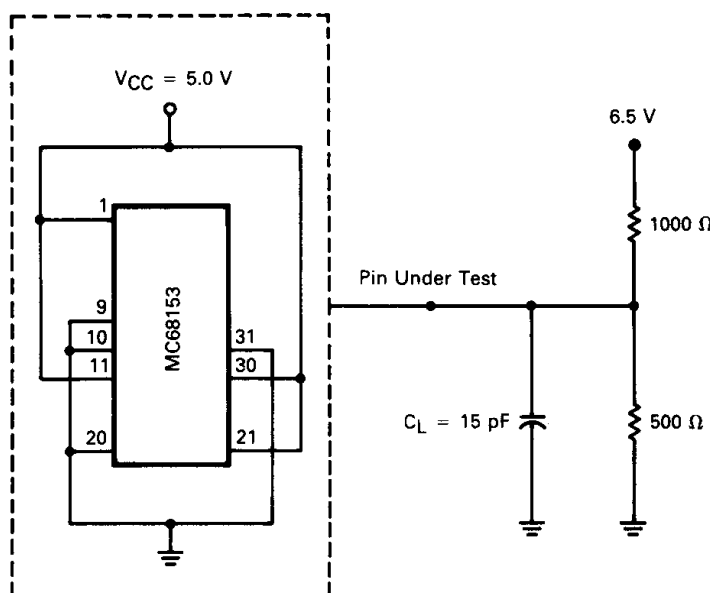
**NOTES:**

- Not applicable to open-collector outputs.
- Not more than one output should be shorted at a time for longer than one second.
- $\overline{CS}$  Low to CLK High (Setup Time) of 15 ns Min must be observed.
- $\overline{IACK}$  Low to CLK High and  $\overline{IACKIN}$  Low to CLK High (Setup Times) of 15 ns Min must be observed.
- See Table 1 for additional performance guidelines.

**AC TEST CIRCUIT — AC Testing of All Outputs**

## MC68153

**TABLE 1**  
**AC PERFORMANCE SPECIFICATIONS**  
(VCC = 5.0 V ±5%, TA = 0°C to 70°C)

Number	Characteristic	Min	Max	Units	Notes
1	R/W, A1-A3 Valid to $\overline{CS}$ Low (Setup Time)	10	—	ns	
2	$\overline{CS}$ Low to R/W, A1-A3 Invalid (Hold Time)	5.0	—	ns	
3	$\overline{CS}$ Low to CLK High (Setup Time)	15	—	ns	1
4	CLK High to Data Out Valid (Delay)	—	55	ns	2
5	CLK High to $\overline{DTACK}$ Low (Delay)	—	40	ns	2
6	$\overline{DTACK}$ Low to $\overline{CS}$ High	0	—	ns	
7	$\overline{CS}$ High to $\overline{DTACK}$ High (Delay)	—	35	ns	10
8	$\overline{CS}$ High to Data Out Invalid (Hold Time)	0	—	ns	
9	$\overline{CS}$ High to Data Out High-Impedance (Hold Time)	—	50	ns	
10	$\overline{CS}$ High to $\overline{CS}$ or $\overline{IACK}$ Low	20	—	ns	
11	Data In Valid to $\overline{CS}$ Low (Setup Time)	10	—	ns	
12	$\overline{CS}$ Low to Data In Invalid (Hold Time)	5.0	—	ns	
13	$\overline{DTACK}$ High to Data Out High-Impedance	—	25	ns	10
14	$\overline{IACK}$ Low to CLK High (Setup Time)	15	—	ns	1
15	A1-A3 Valid to $\overline{IACK}$ Low (Setup Time)	10	—	ns	
16	$\overline{IACK}$ Low to A1-A3 Invalid (Hold Time)	5.0	—	ns	
17	$\overline{IACKIN}$ Low to CLK High (Setup Time)	15	—	ns	1, 8
18	CLK High to Data Out Valid (Delay)	—	55	ns	3
19	CLK High to $\overline{DTACK}$ Low (Delay)	—	40	ns	3
20	CLK High to $\overline{INTAE}$ Low (Delay)	—	40	ns	3
22	$\overline{DTACK}$ Low to $\overline{IACKIN}$ High	0	—	ns	8
23	$\overline{DTACK}$ Low to $\overline{IACK}$ High	0	—	ns	
24	$\overline{IACK}$ High to Data Out Invalid (Hold Time)	0	—	ns	
25	$\overline{IACK}$ High to Data Out High Impedance (Delay)	—	60	ns	
26	$\overline{IACK}$ High to $\overline{DTACK}$ High (Delay)	—	45	ns	10
27	$\overline{IACK}$ High to $\overline{INTAE}$ High (Delay)	—	35	ns	
28	$\overline{INTAL0}$ , $\overline{INTAL1}$ Valid to $\overline{INTAE}$ Low (Setup Time)	1.0	2.0	CLK Per	
29	$\overline{INTAE}$ High to $\overline{INTAL0}$ , $\overline{INTAL1}$ Invalid (Hold Time)	1.0	2.0	CLK Per	
30	$\overline{IACK}$ High to $\overline{IRQx}$ High (Delay)	—	50	ns	7, 10
31	$\overline{IACK}$ High to $\overline{IACK}$ or $\overline{CS}$ Low	20	—	ns	
32	CLK High to $\overline{IACKOUT}$ Low (Delay)	—	40	ns	5
33	$\overline{IACKIN}$ Low to $\overline{IACKOUT}$ Low (Delay)	—	30	ns	4, 8
34	$\overline{IACKOUT}$ Low to $\overline{IACKIN}$ , $\overline{IACK}$ High	0	—	ns	8
35	$\overline{IACK}$ High to $\overline{IACKOUT}$ High (Delay)	—	35	ns	
36	$\overline{IACK}$ and $\overline{CS}$ both Low to CLK High (Setup Time)	15	—	ns	9
37	CLK High to $\overline{IACK}$ or $\overline{CS}$ High (Hold Time)	0	—	ns	
38	$\overline{IACK}$ or $\overline{CS}$ High to $\overline{IACK}$ and $\overline{CS}$ High (Skew)	—	1.0	CLK Per	6
39	Clock Rise Time	—	10	ns	
40	Clock Fall Time	—	10	ns	
41	Clock High Time	20	—	ns	
42	Clock Low Time	20	—	ns	
43	Clock Period	40	—	ns	

**NOTES:**

- This specification only applies if the VBIM had completed all operations initiated by the previous bus cycle when  $\overline{CS}$  or  $\overline{IACK}$  was asserted. Following a normal bus cycle, all operations are completed within 2 clock cycles after  $\overline{CS}$  or  $\overline{IACK}$  have been negated. If  $\overline{IACK}$  or  $\overline{CS}$  is asserted prior to completion of these operations, the new cycle, and hence,  $\overline{DTACK}$  is postponed.  
If the  $\overline{IACK}$ ,  $\overline{IACKIN}$  or  $\overline{CS}$  setup time is violated,  $\overline{DTACK}$  may be asserted as shown, or may be asserted one clock cycle later (i.e.  $\overline{IACK}$  will not be recognized until the next rising edge of the clock).
- Assumes that 3 has been met.
- Assumes that 14 and 17 have both been met.
- Assumes that 14 has been met. ( $\overline{IACKOUT}$  cannot go low prior to  $\overline{IACKIN}$  going low).
- Assumes that 14 has been met and  $\overline{IACKIN}$  has been low for at least the amount of time specified by 33.
- 38 is the minimum skew between the last moment when both  $\overline{IACK}$  and  $\overline{CS}$  are asserted to when both are negated, to insure that an access cycle is not unintentionally started.
- Assumes no other  $\overline{INTx}$  input is causing  $\overline{IRQx}$  to be driven low.
- In non-daisy chain systems,  $\overline{IACKIN}$  may be tied low.
- Failure to meet this spec. causes RESET to be ignored for 1 clock period. It is then necessary to keep these signals low for 3 clock periods instead of 2.
- Delay time is specified from Input signal to Open-Collector Output pulled High thru 1.0kΩ resistor to +6.5 V.

8

**AC ELECTRICAL SPECIFICATIONS** ( $V_{CC} = 5.0\text{ V} \pm 5\%$ ,  $T_A = 0^\circ\text{C}$  to  $70^\circ\text{C}$ )

Parameter	Test Number(5)	Max (ns)
CLK High to Data Out Valid (Delay)(3)	1	55
CLK High to DTACK Low (Delay)(3)	2	40
CS High to DTACK High (Delay)	3	35
CLK High to Data Out Valid (Delay)(4)	4	55
CLK High to INTAE Low (Delay)(4)	5	40
IACK High to Data Out High Impedance (Delay)	6	60
IACK High to DTACK High (Delay)	7	45
CS High to Data Out High (Delay)	8	45
CS High to IRQ High (Delay)	9	60
IACK High to INTAE High (Delay)	10	35

**GENERAL DESCRIPTION**

The MC68153 Bus Interrupter Module (BIM) is designed to serve as an interrupt requester for peripheral devices in a microcomputer system. Up to 4 independent devices can be interfaced to the system bus by the MC68153. Intended for asynchronous master/slave bus operation, the BIM is compatible with VERSAbus, VMEbus, MC68000 device bus, and other system buses. Figure 1 shows a block diagram of a typical configuration. In this example, three peripheral devices (bus slaves) are connected to the system data bus. Each of these devices could be parallel I/O, serial I/O, or some other function. An interrupt request from any device is routed to the MC68153, and the BIM handles all interface to the system bus. It generates a bus interrupt request as a result of the device interrupt request. When the system interrupt handler or processor responds with an interrupt acknowledge cycle, the MC68153 can answer supplying an interrupt vector and handling all timing.

The functional block diagram of the MC68153 is shown in Figure 2. The device contains circuitry to accept four separate interrupt sources ( $\overline{\text{INT0}} - \overline{\text{INT3}}$ ). Interface to the system bus includes generation of bus interrupt requests ( $\overline{\text{IRQ1}} - \overline{\text{IRQ7}}$ ), response to a bus interrupt acknowledge cycle (either supplying a vector or passing on a daisy chain signal), and releasing the bus interrupt request signal at the proper time. The BIM has flexibility provided by eight programmable read/write registers. Four 8-bit vector registers ( $\text{VR0} - \text{VR3}$ ) contain status/address information and supply a byte vector in response to an interrupt acknowledge cycle for the corresponding interrupt source. Four other 8-bit control registers ( $\text{CR0} - \text{CR3}$ ) contain information that oversees operation of the interrupt circuitry. The control information is programmable and includes interrupt request level and interrupt enable and disable. Also contained in the control registers are flag-bits. These flags are useful for task coordination, resource management, and interprocessor communication.

**SIGNAL DESCRIPTION**

Throughout the data sheet, signals are presented using the terms asserted and negated independent of whether the signal is asserted in the high voltage or low voltage state. Active low signals are denoted by a superscript bar.

**BIDIRECTIONAL DATA BUS — D0 – D7**

Pins D0 – D7 form an 8-bit bidirectional data bus to/from the system bus. These are active high, 3-state pins. D7 is the most significant bit.

**ADDRESS INPUTS — A1 – A3**

These active high inputs serve two functions. One function is to select one of the eight possible registers during a read or write cycle. Secondly, during an interrupt acknowledge A1 – A3 show the level of interrupt being acknowledged, and the BIM uses these to determine if a match exists with an internal level.

**CHIP SELECT —  $\overline{\text{CS}}$** 

$\overline{\text{CS}}$  is an active low input used to select the BIM's registers for the current bus cycle. Address strobe, data strobe, and appropriate address bits must be included in the chip select equation.

**READ/WRITE —  $\overline{\text{R/W}}$** 

The  $\overline{\text{R/W}}$  input is a signal from the system bus used to determine if the current bus cycle is a read (high) or write (low).

**DATA TRANSFER ACKNOWLEDGE —  $\overline{\text{DTACK}}$** 

$\overline{\text{DTACK}}$  is an open-collector, active low output that signals the completion of a read, write, or interrupt acknowledge cycle. During read or interrupt acknowledge cycles,  $\overline{\text{DTACK}}$  is asserted by the MC68153 after data has been provided on the data bus; during write cycles it is asserted after data has been accepted from the data bus. A pullup resistor is required to maintain  $\overline{\text{DTACK}}$  high between bus cycles.

## MC68153

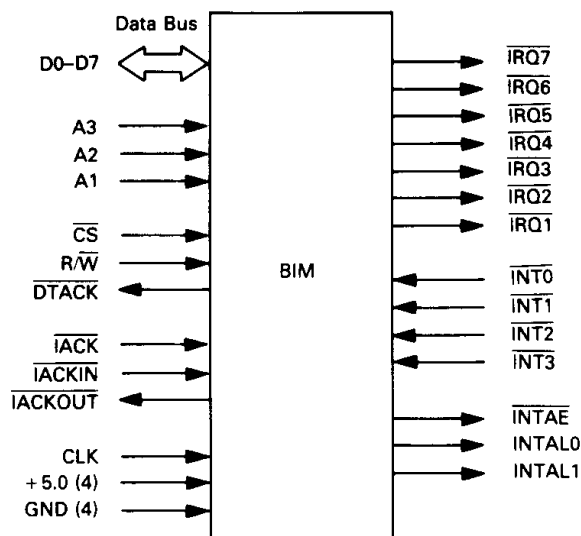

FIGURE 3 — LOGICAL PIN ASSIGNMENT

**INTERRUPT ACKNOWLEDGE SIGNALS —  $\overline{\text{IACK}}$ ,  $\overline{\text{IACKIN}}$ ,  $\overline{\text{IACKOUT}}$** 

These three pins support the interrupt acknowledge cycle. A low level on the  $\overline{\text{IACK}}$  input indicates an interrupt acknowledge cycle has been initiated. This signal is conditioned externally with Address Strobe and the lower data strobe of an MC68000 type bus. After  $\overline{\text{IACK}}$  is asserted the BIM compares the interrupt level presented on address lines A1, A2, and A3 with the current levels generated internally and determines if a match exists. Then, if input  $\overline{\text{IACKIN}}$  is asserted (driven low), the BIM will either complete the interrupt acknowledge cycle if a match exists or assert output  $\overline{\text{IACKOUT}}$  if no match exists.

$\overline{\text{IACKIN}}$  and  $\overline{\text{IACKOUT}}$  form part of a prioritized interrupt acknowledge daisy chain. The daisy chain prioritizes interrupters and guarantees that two or more devices requesting an interrupt on the same level will not respond to the same cycle. The requesting device (or interrupter) must wait until  $\overline{\text{IACKIN}}$  is asserted and not pass the signal on (assert  $\overline{\text{IACKOUT}}$ ) if it is to complete the interrupt acknowledge cycle.

**BUS INTERRUPT REQUEST SIGNALS —  $\overline{\text{IRQ1}}$  -  $\overline{\text{IRQ7}}$** 

These open-collector outputs are low when asserted, indicating a bus interrupt is requested at the corresponding level. An open-collector buffer is normally required for sufficient drive when interfacing to a system bus. A pullup resistor is required to maintain  $\overline{\text{IRQ1}}$  -  $\overline{\text{IRQ7}}$  high between interrupt requests.

**DEVICE INTERRUPT REQUEST SIGNALS —  $\overline{\text{INT0}}$  -  $\overline{\text{INT3}}$** 

$\overline{\text{INT0}}$  -  $\overline{\text{INT3}}$  are active low inputs used to indicate to the BIM that a device wants a bus interrupt.

**INTERRUPT ACKNOWLEDGE ENABLE —  $\overline{\text{INTAE}}$** 

During an interrupt acknowledge cycle, this output pin is asserted low to indicate that outputs  $\overline{\text{INTAL0}}$  and  $\overline{\text{INTAL1}}$  are valid. These two outputs contain an encoded number (x) corresponding to the interrupt ( $\overline{\text{INTx}}$ ) being acknowledged. This feature can be used to signal interrupting devices, which supply their own vector, when to respond to the interrupt acknowledge cycle with the vector and a  $\overline{\text{DTACK}}$  signal.

**INTERRUPT ACKNOWLEDGE LEVEL —  $\overline{\text{INTAL0}}$ ,  $\overline{\text{INTAL1}}$** 

These active high outputs contain an encoded number corresponding to the interrupt level being acknowledged. They are valid only when  $\overline{\text{INTAE}}$  is asserted low.

**CLOCK — CLK**

The CLK input is used to supply the clock for internal operations of the MC68153.

**RESET —  $\overline{\text{CS}}$ ,  $\overline{\text{IACK}}$** 

Although a reset input is not supplied, an on-board reset is performed if  $\overline{\text{CS}}$  and  $\overline{\text{IACK}}$  are asserted simultaneously.

ADDRESS BIT			REGISTER BIT								REGISTER NAME
A3	A2	A1	7	6	5	4	3	2	1	0	
0	0	0	F	FAC	X/ $\overline{\text{IN}}$	IRE	IRAC	L2	L1	L0	CONTROL REGISTER 0
0	0	1	F	FAC	X/ $\overline{\text{IN}}$	IRE	IRAC	L2	L1	L0	CONTROL REGISTER 1
0	1	0	F	FAC	X/ $\overline{\text{IN}}$	IRE	IRAC	L2	L1	L0	CONTROL REGISTER 2
1	1	1	F	FAC	X/ $\overline{\text{IN}}$	IRE	IRAC	L2	L1	L0	CONTROL REGISTER 3
1	0	0	V7	V6	V5	V4	V3	V2	V1	V0	VECTOR REGISTER 0
1	0	1	V7	V6	V5	V4	V3	V2	V1	V0	VECTOR REGISTER 1
1	1	0	V7	V6	V5	V4	V3	V2	V1	V0	VECTOR REGISTER 2
1	1	1	V7	V6	V5	V4	V3	V2	V1	V0	VECTOR REGISTER 3

FIGURE 4 — MC68153 REGISTER MODEL

### REGISTER DESCRIPTION

The MC68153 contains 8 programmable read/write registers. There are four control registers (CR0 – CR3) that govern operation of the device. The other four (VR0 – VR3) are vector registers that contain the vector data used during an interrupt acknowledge cycle. Figure 4 illustrates the device register model.

### CONTROL REGISTERS

There is a control register for each interrupt source, i.e., CR0 controls  $\overline{\text{INT0}}$ , CR1 controls  $\overline{\text{INT1}}$ , etc. The control registers are divided into several fields:

1. Interrupt level (L2, L1, L0) — The least significant 3-bit field of the register determines the level at which an interrupt will be generated:

L2	L1	L0	IRQ LEVEL
0	0	0	DISABLED
0	0	1	IRQ1
0	1	0	IRQ2
0	1	1	IRQ3
1	0	0	IRQ4
1	0	1	IRQ5
1	1	0	IRQ6
1	1	1	IRQ7

A value of zero in the field disables the interrupt.

2. Interrupt Enable (IRE) — This field (Bit 4) must be set (high level) to enable the bus interrupt request associated with the control register. Thus, if the  $\overline{\text{INTX}}$  line is asserted and IRE is cleared, no interrupt request ( $\overline{\text{IRQX}}$ ) will be asserted.
3. Interrupt Auto-Clear (IRAC) — If the IRAC is set (Bit 3), IRE (Bit 4) is cleared during an interrupt acknowledge cycle responding to this request. This action of

clearing IRE disables the interrupt request. To re-enable the interrupt associated with this register, IRE must be set again by writing to the control register.

4. External/Internal (X/ $\overline{\text{IN}}$ ) — Bit 5 of the control register determines the response of the MC68153 during an interrupt acknowledge cycle. If the X/ $\overline{\text{IN}}$  bit is clear (low level) the BIM will respond with vector data and a  $\overline{\text{DTACK}}$  signal, i.e., an internal response. If X/ $\overline{\text{IN}}$  is set, the vector is not supplied and no  $\overline{\text{DTACK}}$  is given by the BIM, i.e., an external device should respond.
5. Flag (F) — Bit 7 is a flag that can be used in conjunction with the test and set instruction of the MC68000. It can be changed without affecting chip operation. It is useful for processor-to-processor communication and resource allocation.
6. Flag Auto-Clear (FAC) — If FAC (Bit 6) is set, the Flag bit is automatically cleared during an interrupt acknowledge cycle.

### VECTOR REGISTERS

Each interrupt input has its own associated vector register. Each register is 8 bits wide and supplies a data byte during its interrupt acknowledge cycle if the associated External/Internal (X/ $\overline{\text{IN}}$ ) control register bit is clear (zero). This data can be status, identification, or address information depending on system usage. The information is programmed by the system user.

### DEVICE RESET

When the MC68153 is reset, the registers are set to a known condition. The control registers are set to all zeros (low). The vector registers are set to \$0F. This value is the MC68000 vector for an uninitialized interrupt vector.

## MC68153

## FUNCTIONAL DESCRIPTION

## SYSTEM OVERVIEW

The MC68153 can be used with many system buses, however, it is primarily intended for VMEbus, VERSAbus and MC68000 applications. Figure 5 shows a system configuration similar to VMEbus. In the figure only one system Data Transfer Bus (DTB) master is used. The Priority Interrupt structure provides a means for peripheral slave devices to ask for an interrupt of other processor (DTB master) activity and receive service from the processor. The MC68153 BIM acts as an interface device requesting and responding to interrupt acknowledge cycles for up to 4 independent slaves.

In Figure 5, functional modules are identified as Interrupters and an Interrupt Handler. An Interrupter (such as the MC68153) receives slave requests for an interrupt and handles all requests to the system bus required to ask for and respond to interrupt requests. The Interrupt Handler receives the bus interrupt requests, determines when an interrupt acknowledge will occur and at which level, and finally either performs the interrupt acknowledge (IACK) cycle or tells the DTB master to execute the IACK cycle.

The signal lines in the Priority Interrupt structure include (\* — indicates active low):

1. IRQ1\*–IRQ7\* — seven prioritized interrupt request lines.

2. IACK\* — signal line that indicates an interrupt acknowledge cycle is occurring.
3. IACKIN\*/IACKOUT\* — two signals that form part of a daisy chain that prioritizes interrupters.

In addition Data Transfer Bus control signals are involved in the IACK bus cycle:

1. AS\* — the Address Strobe asserted low indicates a valid address is on the bus.
2. DSO\* — the lower Data Strobe asserted low indicates a data transfer will occur on bus bits D00–D07.
3. WRITE\* — the Read/Write is negated indicating the data is to be read from the Interrupter.
4. A01–A03 — Address lines A01–A03 contain the encoded priority level of the IACK cycle.
5. D00–D07 — Data bus lines D00–D07 are used to pass the interrupt vector from the responding Interrupter to the Interrupt Handler.
6. DTACK\* — Data Transfer Acknowledge asserted low signals that the Interrupter has put the vector on the data bus.

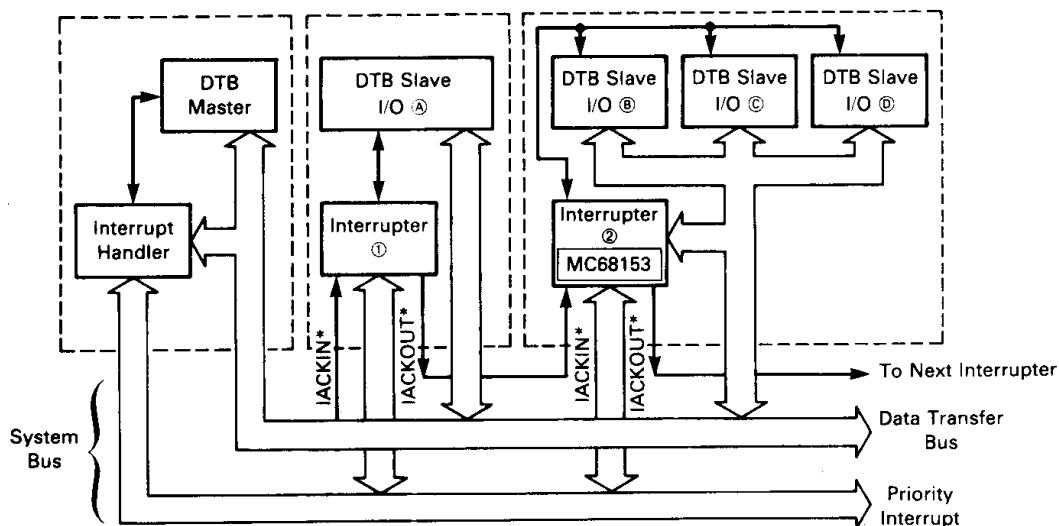

FIGURE 5 — SIMPLE VMEbus CONFIGURATION



Figure 6 shows a flow diagram of a typical interrupt request and acknowledge operation. Briefly, the sequence of events is first, an Interrupter makes a request, next the Handler responds with an IACK cycle, then the Interrupter passes a vector to the Handler completing the IACK cycle, and finally the Handler uses the vector to determine additional action. Typically, an interrupt service routine is stored in software and the vector determines where its starting address is stored.

Note the daisy chain operation. If the IACK level (on A01–A03) does not match the Interrupter's request level or if no request is pending, the Interrupter passes the IACKIN\* signal on and asserts IACKOUT\*. This sequential action automatically prioritizes Requesters on the same level (first one in line with a request pending gets serviced) and prevents two or more Interrupters from responding simultaneously.

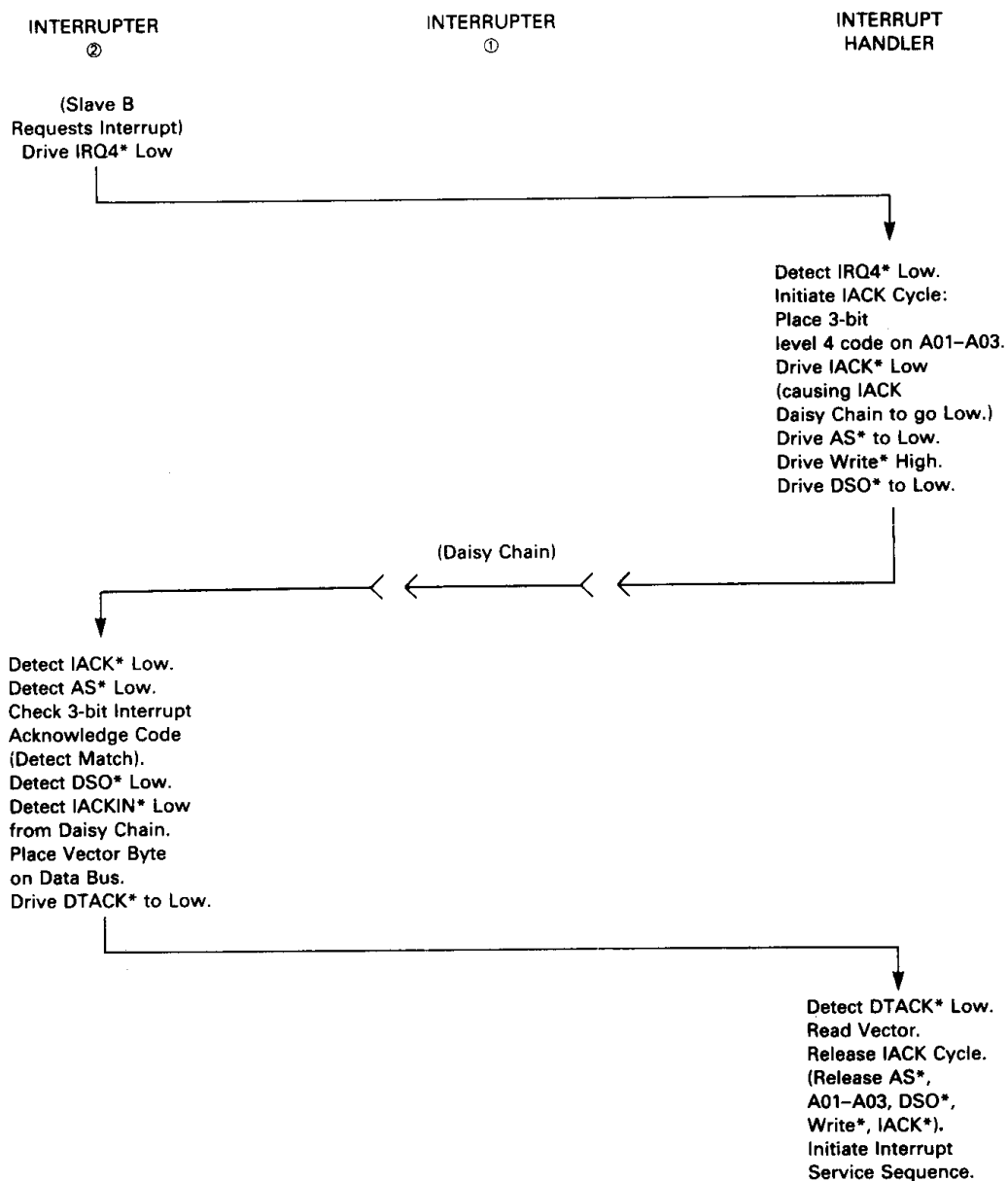

FIGURE 6 — INTERRUPT REQUEST AND ACKNOWLEDGE OPERATION FLOW DIAGRAM

## MC68153

This discussion is a very cursory look at the bus operation. For more details including situations with multiple bus masters, the user is directed to the VMEbus Specification MVMEBS or VERSAbus Specification M68KVBS. Also, the MC68153 can be used with other buses having similar interrupt structures.

### BIM BUS INTERFACE

Figure 7 shows a simplified block diagram of the MC68153 interface to VERSAbus or VMEbus. Address Decode and Control Logic are dependent on the application and must be designed to guarantee BIM ac specifications. It is possible in most cases that the decode logic can be shared with the slave devices. Buffers are provided where shown to comply with bus loading and drive specifications. It is also possible that buffers can be shared with the slave bus interface.

### READ/WRITE OPERATION

All eight BIM registers can be accessed from the sys-

tem bus in both read and write modes. The BIM has an asynchronous bus interface, primarily designed for MC68000-like buses. The following BIM signals generate read and write cycles: Chip Select ( $\overline{CS}$ ), Read/Write ( $R/\overline{W}$ ), Address Inputs (A1–A3), Data Bus (D0–D7), and Data Transfer Acknowledge ( $\overline{DTACK}$ ). During read and write cycles the internal registers are selected by A1, A2, and A3 in compliance with the Figure 4 Truth Table.

Figure 8 shows the device timing for a read cycle.  $R/\overline{W}$  and A1–A3 are latched on the falling edge of  $\overline{CS}$  and must meet specified setup and hold times. Chip access time for valid data and  $\overline{DTACK}$  are dependent on the clock frequency as shown in the figure.

Figure 9 shows the device timing for a write cycle.  $R/\overline{W}$ , A1–A3, and D0–D7 are latched on the falling edge of  $\overline{CS}$  and must meet specified setup and hold times. Chip access time for  $\overline{DTACK}$  is dependent on the clock frequency as shown in the figure.

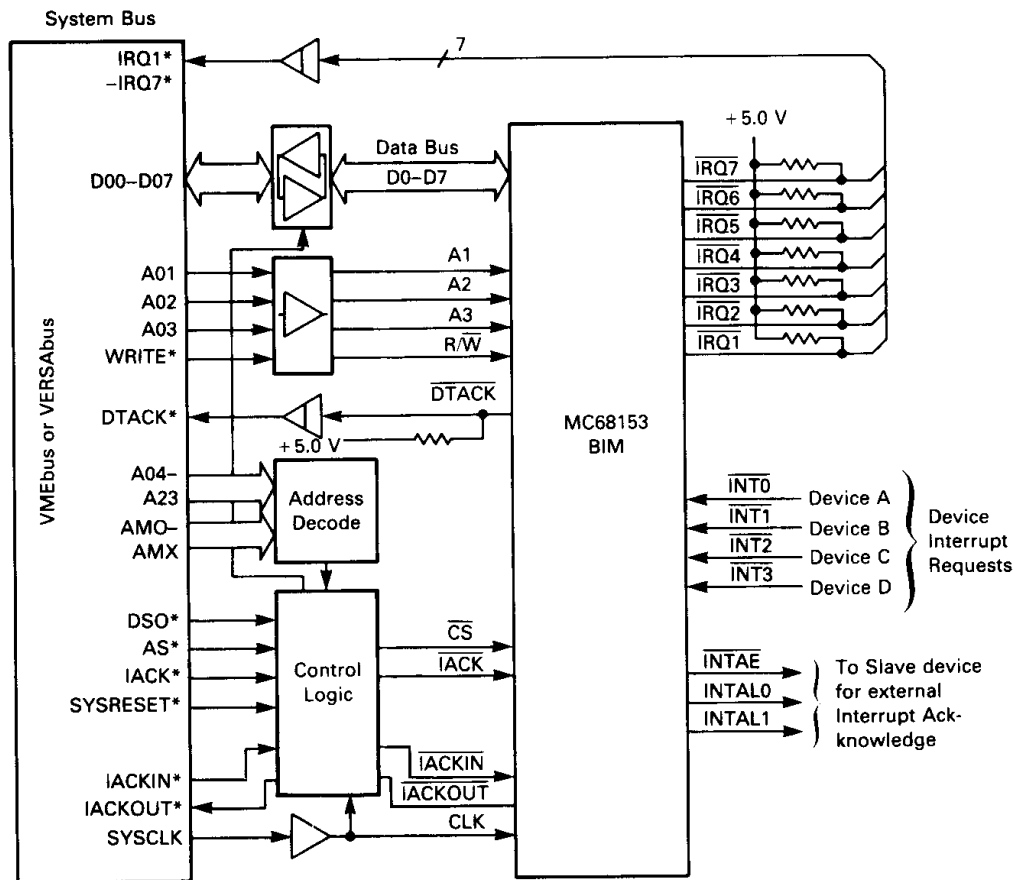

FIGURE 7 — VMEbus/VERSAbus INTERFACE BLOCK DIAGRAM

8

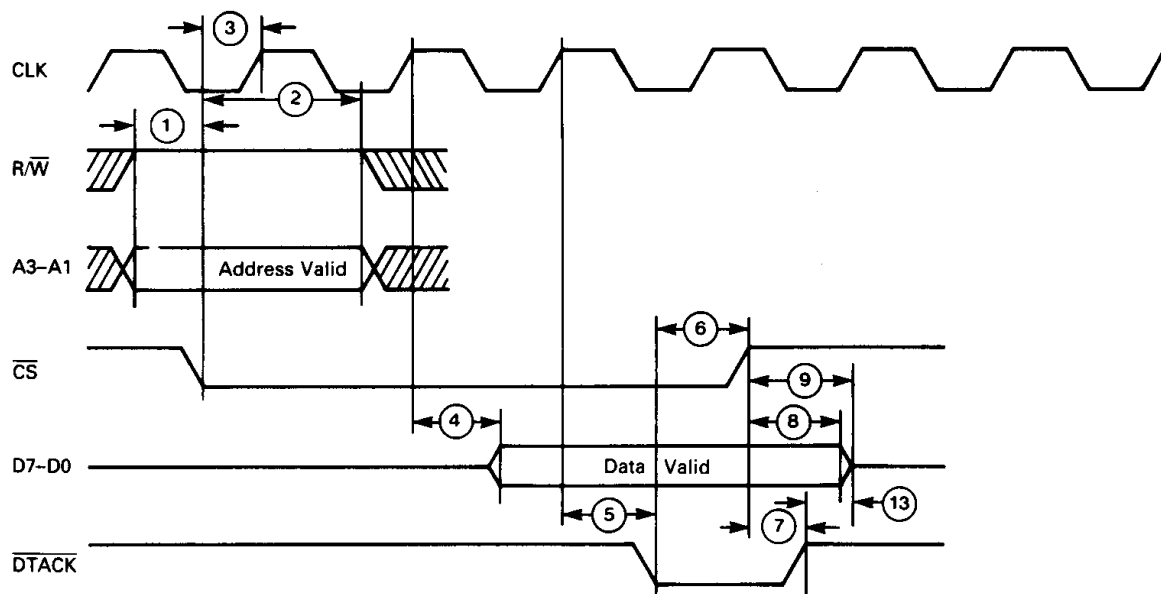

FIGURE 8 — READ CYCLE

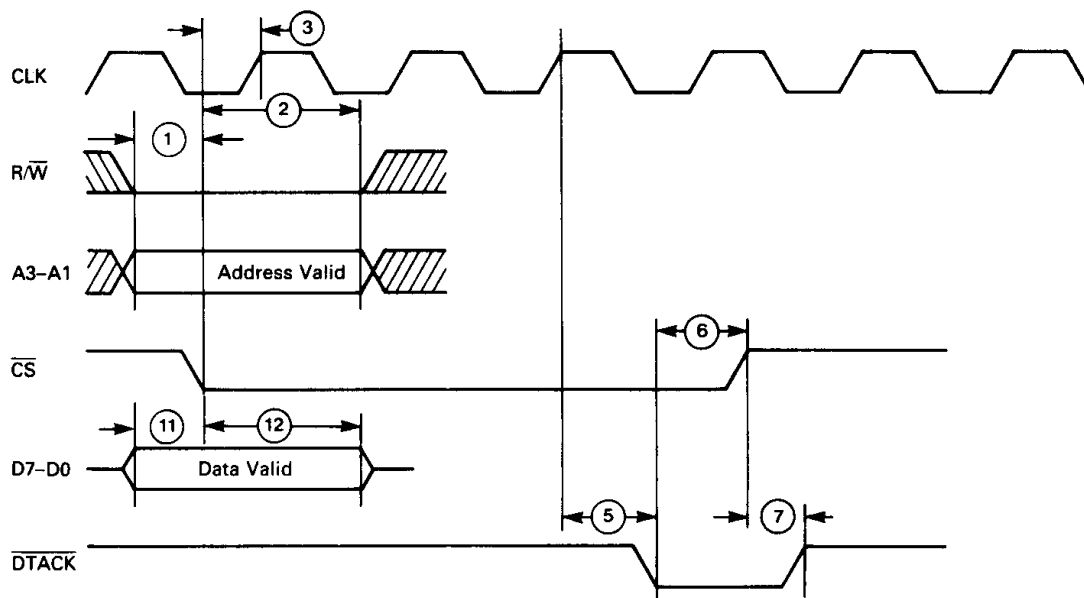

FIGURE 9 — WRITE CYCLE

## MC68153

### INTERRUPT REQUESTS

The MC68153 accepts device interrupt requests on inputs INT0, INT1, INT2, and INT3. Each input is regulated by Bit 4 (IRE) of the associated control register (CR0 controls INT0, CR1 controls INT1, etc). If IRE (Interrupt Enable) is set and a device input is asserted, an Interrupt Request open-collector output (IRQ1–IRQ7) is asserted. The asserted IRQX output is selected by the value programmed in Bits 0, 1, and 2 of the control register (L0, L1, and L2). This 3-bit field determines the interrupt request level as set by software.

Two or more interrupt sources can be programmed to the same request level. The corresponding IRQX output will remain asserted until multiple interrupt acknowledge cycles respond to all requests.

If the interrupt request level is set to zero, the interrupt is disabled because there is no corresponding IRQ output.

### INTERRUPT ACKNOWLEDGE

The response of an Interrupt Handler to a bus interrupt request is an interrupt acknowledge cycle. The IACK cycle is initiated in the MC68153 by receiving IACK low. R/W, A1, A2, A3 are latched, and the interrupt level on line A1–A3 is compared with any interrupt requests pending in the chip. Further activity can be one of four cases:

1. No further action required — This occurs if IACKIN is not asserted. Asserting IACK only starts the BIM activity. If the daisy chain signal never reaches the MC68153 (IACKIN is not asserted), another Interrupter has responded to the IACK cycle. The cycle will end, the chip IACK is negated, and no additional action is required.
2. Pass on the interrupt acknowledge daisy chain — For this case, IACKIN input is asserted by the preceding daisy chain Interrupter, and IACKOUT output is in turn asserted. The daisy chain signal is passed on when no interrupts are pending on a matching level or when any possible interrupts are disabled. The Interrupt Enable (IRE) bit of a control register can disable any interrupt requests, and in turn, any possible matches.
3. Respond internally — For this case, IACKIN is asserted and a match is found. The MC68153 completes the IACK cycle by supplying an interrupt vector from the proper vector register followed by a DTACK signal asserted. IACKOUT is not asserted because the interrupt acknowledge cycle is completed by this device.

For the MC68153 to respond in this mode of operation, the EXTERNAL/INTERNAL control register bit (X/IN) must be zero. For each source of interrupt request, the associated control register determines the BIM response to an IACK cycle, and the X/IN

bit sets this response either internally ( $X/\overline{IN} = 0$ ) or externally ( $X/\overline{IN} = 1$ ).

4. Respond externally — For the final case, IACKIN is also asserted, a match is found and the associated control register has X/IN bit set to one. The MC68153 does not assert IACKOUT and does assert INTAE low. INTAE signals that the requesting device must complete the IACK cycle (supplying a vector and DTACK) and that the 2-bit code contained on outputs INTAL0 and INTAL1 shows which interrupt source is being acknowledged.

These cases are discussed in more detail in the following paragraphs.

### Internal Interrupt Acknowledge

For an internal interrupt acknowledge to occur, the following conditions must be met:

1. One or more device interrupt inputs (INT0–INT3) has been asserted and corresponding control bit IRE value is one.
2. IACK asserted.
3. A match exists between [A3, A2, A1] and the [L2, L1, L0] field of an enabled, requesting control register. If two or more devices are requesting at the same interrupt level, preference is given to the highest number requester, that is, INT3 has highest priority and INT0 has lowest.
4. Control register bit X/IN of matching interrupt source must be zero.
5. IACKIN asserted.

The internal interrupt acknowledge cycle timing is shown in Figure 10. The 8-bit interrupt acknowledge vector is presented to the data bus and DTACK is asserted. Note also that INTAL0 and INTAL1 are valid and INTAE is asserted during this cycle although they would normally not be used. The cycle is terminated (data and DTACK released) after IACK is negated.

During the IACK cycle, the INTERRUPT AUTO-CLEAR control bit (IRAC) comes into play. If the IRAC = one for the responding interrupt source, the INTERRUPT ENABLE (IRE) bit is automatically cleared during the IACK cycle, thus disabling the associated interrupt input and any IRQX output asserted due to this interrupt input. Before another interrupt can be requested from this source, IRE must be set to one by writing to the control register.

Note that IACKOUT is not asserted because this device is responding to the IACK and does not pass the daisy chain signal on. Also, new device interrupt requests occurring on INT0–INT3 after IACK is asserted are locked out to prevent any race conditions on the daisy chain.

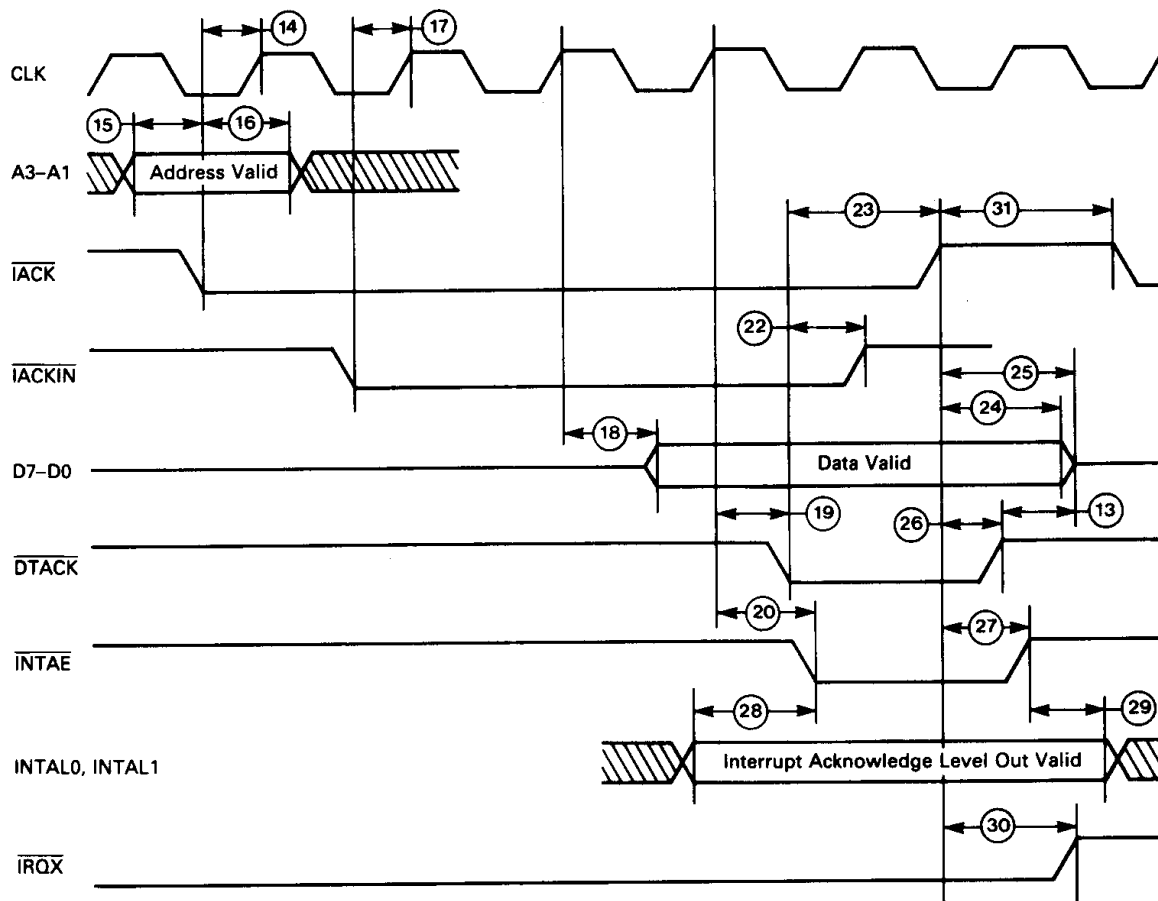

FIGURE 10 — INTERRUPT ACKNOWLEDGE CYCLE — INTERNAL VECTOR

#### External Interrupt Acknowledge

For an external interrupt acknowledge, the same conditions as listed above are met with one exception. Control register bit  $X/\overline{IN}$  of matching interrupt source must be set to one. The timing is shown in Figure 11. For this cycle, the interrupt vector and  $\overline{DTACK}$  must be supplied by an external device.  $\overline{INTAE}$  is asserted indicating that  $\overline{INTAL0}$  and  $\overline{INTAL1}$  are valid. The external device can use these signals to enable the vector and  $\overline{DTACK}$ . The cycle is terminated after  $\overline{IACK}$  is negated.

The IRAC control bit acts in the external interrupt acknowledge the same as described for the internal response (see above). Also,  $\overline{IACKOUT}$  is not asserted and new device interrupts are disabled for reasons discussed above.

#### Pass On IACK Daisy Chain

If the MC68153 has no interrupt request pending at the same level as the interrupt acknowledge, the  $\overline{IACK}$  daisy chain signal is passed on to the next device if  $\overline{IACKIN}$  is asserted. The following conditions are thus met:

1.  $\overline{IACK}$  asserted.
2. No match exists between [A3, A2, A1] and the [L2, L1, L0] field of an enabled, requesting control register.
3.  $\overline{IACKIN}$  is asserted.

$\overline{IACKOUT}$  is asserted if these conditions are valid. This output drives  $\overline{IACKIN}$  of the next Interrupter on the daisy chain, passing the signal along. Figure 12 shows the timing for this case.  $\overline{IACKOUT}$  is negated after  $\overline{IACK}$  is negated.

MC68153

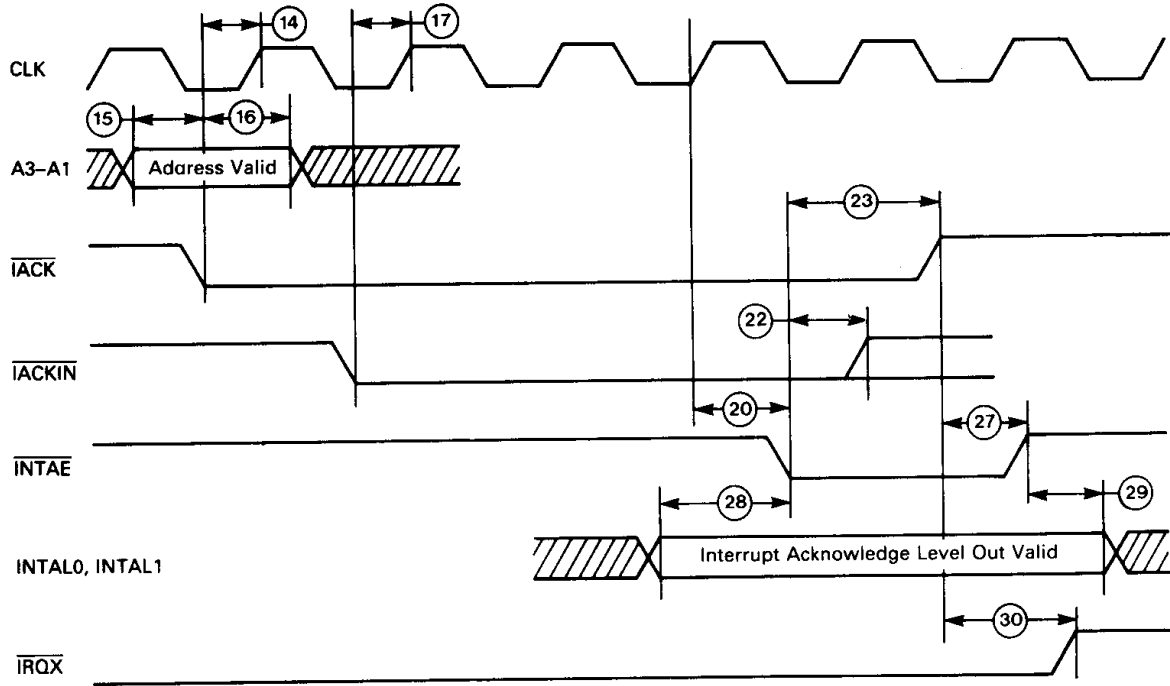

FIGURE 11 — INTERRUPT ACKNOWLEDGE CYCLE — EXTERNAL VECTOR

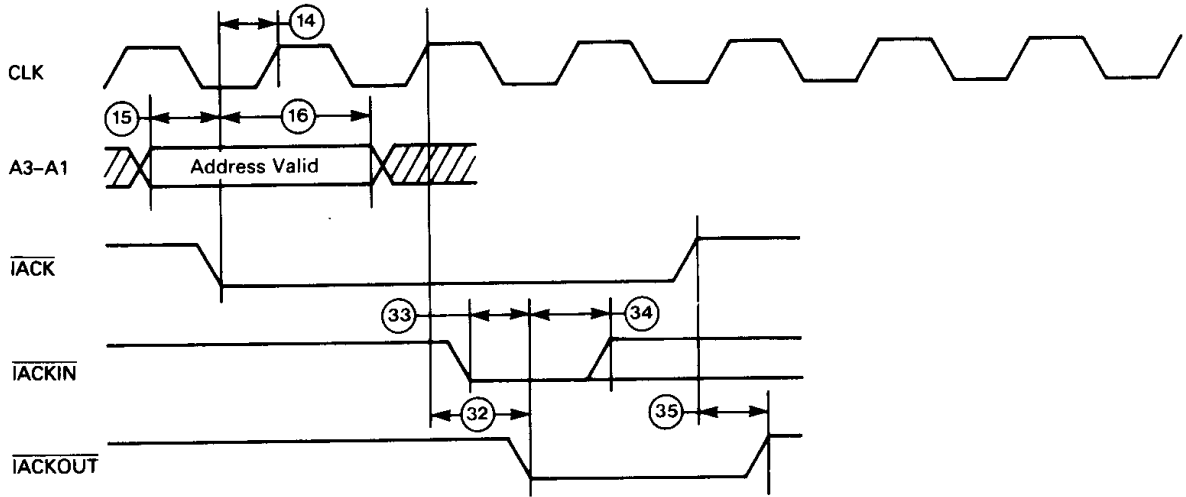

FIGURE 12 — INTERRUPT ACKNOWLEDGE CYCLE — IACKOUT

8

### CONTROL REGISTER FLAGS

Each control register contains a Flag bit (F) and a Flag Auto-Clear bit (FAC). Both bits can be read or altered via a register write without affecting the interrupt operation of the device. The Flag is useful as a status indicator for resource management and as a semaphore in multitasking or multiprocessor systems. Flag (F) is located in bit position 7 and can be used with the MC68000 Test and Set (TAS) instruction.

The Flag Auto-Clear (FAC) is used to manipulate the Flag bit. If the Flag is set to one and the FAC is also one, an interrupt acknowledge cycle to the associated interrupt source clears the Flag bit. This feature is useful in determining the interrupt status and passing messages.

### RESET

There is no reset input, however, a chip reset is activated by asserting both  $\overline{CS}$  and  $\overline{IAK}$  simultaneously (Figure 13). These inputs should be held low for a minimum of two clock cycles for a full reset function. The control registers are reset to all zeroes and the Vector Registers are set to a value of \$0F. This vector value is the uninitialized vector for the MC68000. See the MC68000 Users Manual for more details on this vector.

### CLOCK

The chip clock is required for internal operation to occur. Typical frequency is 16 MHz in VMEbus and VERSAbus applications derived from the system clock. Any frequency can be used, however, up to 25 MHz (Figure 14).

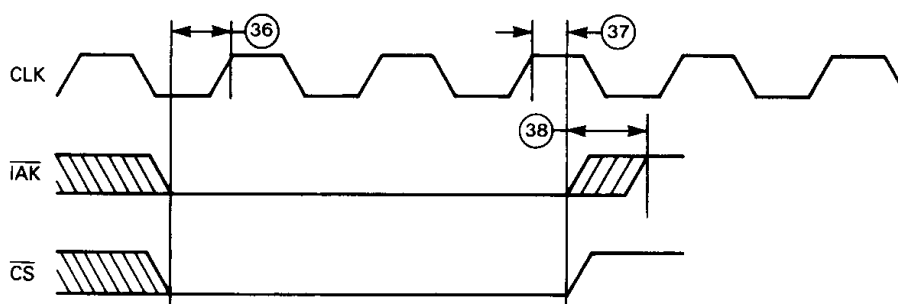

FIGURE 13 — RESET

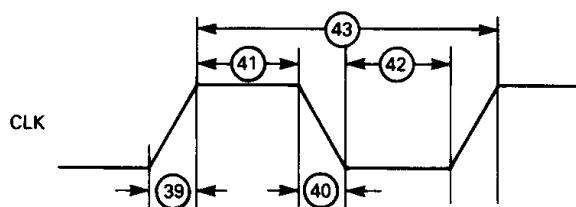

FIGURE 14 — CLOCK WAVEFORM

### TYPICAL THERMAL CHARACTERISTICS

Package	$\theta_{JA}$ (Junction to Ambient) Still Air	Junction Temperature Still Air @ 70°C Ambient
L Suffix	40°C/W	147°C
P Suffix <sup>1</sup>	35°C/W	137°C

#### NOTES:

- For reliable system operation the maximum allowable junction temperature ( $T_J$ ) for plastic encapsulated packages has been limited to +140°C. Exceeding this limit will accelerate "wear-out" mechanisms associated with industry standard assembly methods using thermosonic ball bonds to attach gold ( $A\mu$ ) bond wire to aluminum (Al) bond pads on the die surface.
- At  $T_J = 140^\circ\text{C}$ , time to 0.1% failure due to  $A\mu\text{Al}$  interconnect = 8,920 Hours.

# MC68153

## PIN ASSIGNMENTS

