

ABOV SEMICONDUCTOR Co. Ltd.
8-BIT SINGLE-CHIP MICROCONTROLLERS

MC80F7708A

User's Manual (Ver. 1.11)



Version 1.11

**Published by
FAE Team**

©2007 ABOV Semiconductor Co., Ltd. All rights reserved.

Additional information of this manual may be served by ABOV Semiconductor offices in Korea or Distributors.

ABOV Semiconductor reserves the right to make changes to any information here in at any time without notice.

The information, diagrams and other data in this manual are correct and reliable; however, ABOV Semiconductor is in no way responsible for any violations of patents or other rights of the third party generated by the use of this manual.

REVISION HISTORY

VERSION 1.11 (December 3, 2012) This book

ABOV logo is renewed on this book.

Single and Gang writer are added in "1.3 Development Tools" on page 3.

VDD voltage for sub-active mode is changed to 3.0~5.5V in "7.2 Recommended Operating Conditions" on page 16.

VERSION 1.1 (March 2, 2010)

The errata are fixed at "Figure 17-2 Interrupt Enable Registers and Interrupt Request Registers" on page 73

VERSION 1.0 (December 21, 2009)

The note of watch timer interrupt request flag(WTIF) is added in "13. WATCH TIMER" on page 61.

The value of conversion time at "7.5 A/D Converter Characteristics" on page 18 is modified to prevent confusion.

ADC interrupt function is eliminated in MC80F7708A, so the description of "ADC interrupt function" is deleted in this manual. ie. ADCE(bit0 of IENM) is eliminated.

The description of "configuration option bit" is modified to prevent confusion in "25.1 FLASH Configuration Byte" on page 99.

The description of f_{MAIN} is added in this manual. ie. f_{MAIN} is main-clock frequency at main-active mode and it is sub-clock frequency at sub-active mode.

f_{MAIN} : main-clock frequency at main-active mode
sub-clock frequency at sub-active mode

VERSION 0.1 (August 21, 2009)

The figures of flash writer were updated in "1. OVERVIEW" on page 1.

VERSION 0.0 (July 2, 2009)

First Edition (Preliminary)

Table of Contents

1. OVERVIEW	1	16. BUZZER OUTPUT FUNCTION	69
Description	1	17. INTERRUPTS	71
Features	1	Interrupt Sequence	74
Development Tools	3	BRK Interrupt	75
Ordering Information	5	Multi Interrupt	75
2. BLOCK DIAGRAM	6	External Interrupt	77
3. PIN ASSIGNMENT	7	18. LCD DRIVER	78
4. PACKAGE DIAGRAM	8	Control of LCD Driver Circuit	79
5. PIN FUNCTION	10	LCD BIAS Control	81
6. PORT STRUCTURES	13	LCD Display Memory	82
7. ELECTRICAL CHARACTERISTICS	16	Control Method of LCD Driver	83
Absolute Maximum Ratings	16	Duty and Bias Selection of LCD Driver	85
Recommended Operating Conditions	16	19. OPERATION MODE	86
DC Electrical Characteristics	17	Operation Mode Switching	87
LCD Characteristics	18	20. POWER DOWN OPERATION	88
A/D Converter Characteristics	18	SLEEP Mode	88
AC Characteristics	19	STOP Mode	89
Typical Characteristics	21	21. OSCILLATOR CIRCUIT	93
8. MEMORY ORGANIZATION	22	22. RESET	94
Registers	22	External Reset Input	94
Program Memory	25	Power On Reset	95
Data Memory	28	SVLD Reset	95
Addressing Mode	32	Watchdog Timer Reset	95
9. I/O PORTS	36	23. Supply Voltage Level Detector (SVLD)	96
Registers for Ports	36	24. Oscillation Noise Protector	98
I/O Ports Configuration	37	25. FLASH PROGRAMMING SPEC.	99
10. CLOCK GENERATOR	41	FLASH Configuration Byte	99
11. BASIC INTERVAL TIMER	43	FLASH Programming	100
12. TIMER / COUNTER	45	26. EMULATOR EVA. BOARD SETTING	101
8-Bit Timer/Counter Mode	49	27. IN-SYSTEM PROGRAMMING	105
16 Bit Timer/Counter Mode	51	Getting Started / Installation	105
8-Bit Capture Mode	53	Basic ISP S/W Information	106
16-bit Capture Mode	57	Hardware Conditions to Enter the ISP Mode	107
8-Bit (16-Bit) Compare Output Mode	58	Sequence to enter ISP mode/user mode	108
PWM Mode	58	Reference ISP Circuit Diagram and ABOV Supplied ISP Board	109
13. WATCH TIMER	61	A. INSTRUCTION	ii
14. WATCH DOG TIMER	64	Terminology List	ii
15. ANALOG TO DIGITAL CONVERTER	66	Instruction Map	iii
		Instruction Set	iv

MC80F7708A

CMOS SINGLE-CHIP 8-BIT MICROCONTROLLER WITH LCD CONTROLLER/DRIVER

1. OVERVIEW

1.1 Description

The MC80F7708A are an advanced CMOS 8-bit microcontroller with 8K bytes of FLASH ROM(ISP). This device is one of the MC800 family and a powerful microcontroller which provides a high flexibility and cost effective solution to many LCD applications. The MC80F7708A provide the following standard features: 8K bytes of FLASH ROM, 256 bytes of RAM, 20 bytes of segment LCD display RAM, 8/16-bit timer/counter, 8-bit A/D converter, 7-bit watch dog timer, 21-bit watch timer with 7-bit auto reload counter, on-chip oscillator and clock circuitry. In addition, this device supports power saving modes to reduce power consumption. So the MC80F7708A is the best controller solution in system which uses charatered LCD display and ADC.

Device name	Memory (Bytes)		ADC	PWM	I/O	LCD	Operating Voltage	Package
	ROM	RAM						
MC80F7708AQ	8K	256	6ch.	1ch.	42	(20SEG x 4COM)	2.2 ~ 5.5V @4Mhz 4.5 ~ 5.5V @12Mhz	44MQFP
MC80F7708AK	8K	256	4ch	1ch	30	(10SEG x 4COM)	2.2 ~ 5.5V @4Mhz 4.5 ~ 5.5V @12Mhz	32SDIP
MC80F7708AD	8K	256	4ch.	1ch.	30	(10SEG x 4COM)	2.2 ~ 5.5V @4Mhz 4.5 ~ 5.5V @12Mhz	32SOP

1.2 Features

- **8K Bytes On-chip FLASH ROM (ISP)**
- **FLASH Memory**
 - Endurance : 100 cycles
 - Data Retention : 10 years
- **256 Bytes On-chip Data RAM**
- **20 bytes Display RAM**
- **Instruction Cycle Time**
 - 333ns at 12MHz (2 cycle NOP instruction)
- **LCD display/controller**
 - 1/4 Duty Mode (20Seg(10Seg) × 4Com, 1/3 Bias)
- **Four 8-bit Timer/Counter**
 - (They can be used as two 16-bit Timer/Counter)
- **One 7-bit Watch Dog Timer**
- **One 21-bit Watch Timer**
 - 1 minute interrupt available
- **One 8-bit Basic Interval Timer**
- **One 6-bit Buzzer Driving Port**
- **Dual Clock Operation**
 - Main Clock : 400kHz ~ 12MHz
 - Sub Clock : 32.768kHz
- **Main Clock Oscillation**
 - Crystal
 - Ceramic Resonator
 - Internal Oscillation : 8MHz/4MHz/2MHz
- **Operating Temperature : -40~85 °C**
- **Built-in Noise Immunity Circuit**
 - Noise Filter
- **Power Down Mode**
 - Main Clock : STOP, SLEEP, Sub_active mode
- **400kHz to 12MHz Wide Operating Frequency**

- **On-Chip POR (Power On Reset)**
 - 2 level (1.9V, 2.7V)
- **Internal Resistor for LCD Bias**
- **Supply Voltage Level Detector(SVLD)**
 - 4 level detector(2.4V,2.7V,3.0V, 3.9V)
- **42/40 Programmable I/O Pins**

MC80F7708AQ	I/O: 17 I : 1 I/O with SEG/COM:24
MC80F7708AK	I/O: 15 I : 1 I/O with SEG/COM:14
MC80F7708AD	I/O: 15 I : 1 I/O with SEG/COM:14

- **6/4-channel 8-bit On-chip A/D Converter**

MC80F7708AQ	6-channel ADC
-------------	---------------

MC80F7708AK	4-channel ADC
MC80F7708AD	4-channel ADC

- **One 10-bit High Speed PWM Output**
- **11 Interrupt sources**
 - External Interrupt : 4
 - Timer : 4
 - WDT, WT, BIT
- **2.2V to 5.5V Wide Operating Voltage Range**
- **44MQFP, 32SDIP, 32SOP Package Types**
 - Available Pb free package

MC80F7708AQ	44MQFP
MC80F7708AK	32SDIP
MC80F7708AD	32SOP

1.3 Development Tools

The MC80F7708A are supported by a full-featured macro assembler, an in-circuit emulator CHOICE-Dr.TM and OTP/FLASH programmers. There are two different type of programmers such as single type and gang type. For mode detail, Macro assembler operates under the MS-Windows 95 and upversioned Windows OS. And HMS800C compiler only operates under the MS-Windows 2000 and upversioned Windows OS.

Please contact sales part of ABOV semiconductor.

Software	- MS-Windows based assembler - MS-Windows based Debugger - MC800 C compiler
Hardware (Emulator)	- CHOICE-Dr. - CHOICE-Dr. EVA80C77x B/D
POD Name	- POD80C77D-44MQ-1010
FLASH Writer	- PGM Plus USB (Single writer) - Stand Alone PGM Plus(Single writer) - Standalone GANG4/8 USB (Gang writer) - USB-SIO-ISP Board



Figure 1-2 PGM plus USB (Single Writer)



Figure 1-3 Stand Alone PGM_Plus(ISP)



Figure 1-1 Choice-Dr. (Emulator, USB Interface)



Figure 1-4 Stand Alone Gang4 USB (Gang Writer)



Figure 1-6 USB-SIO-ISP Board

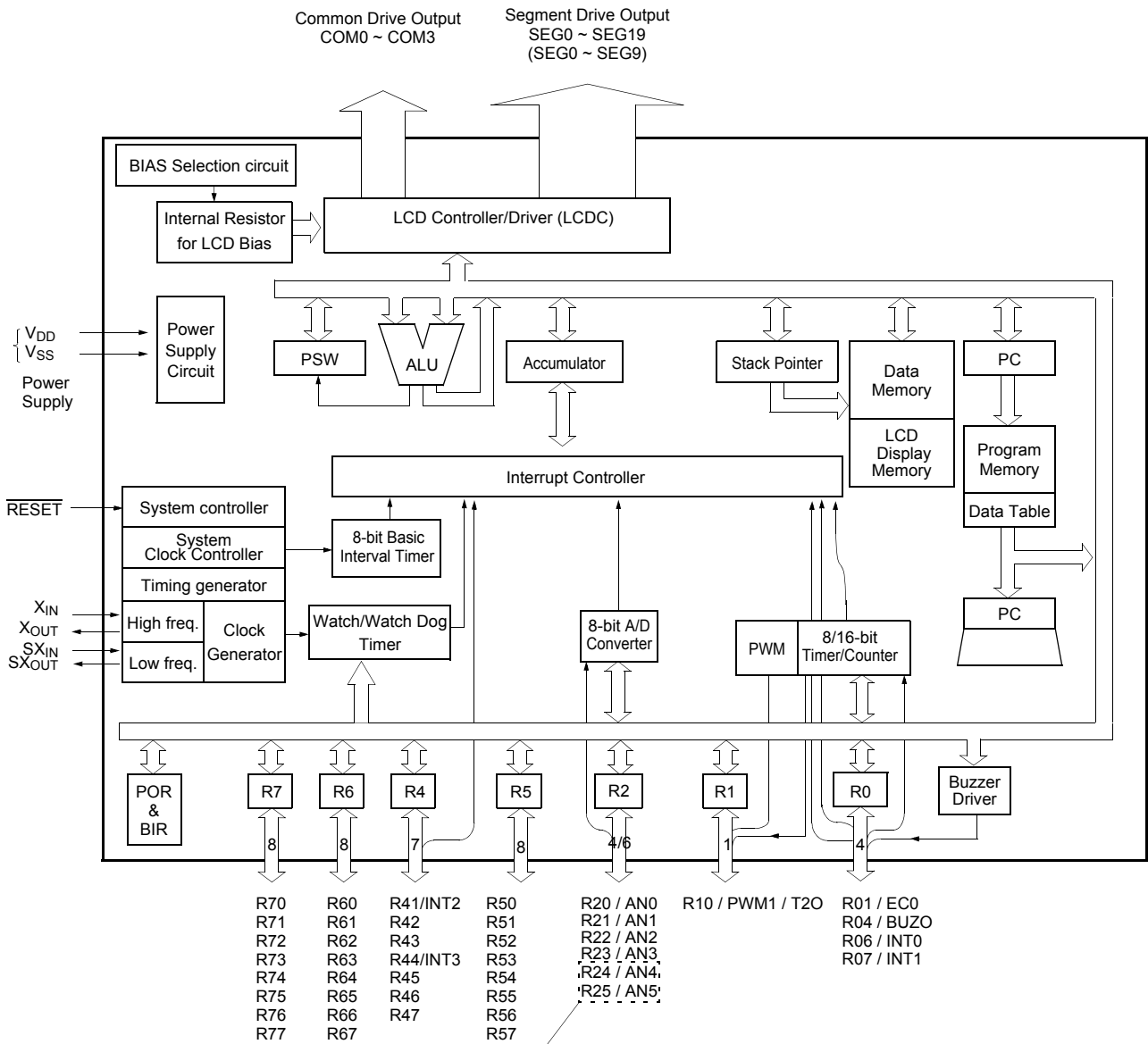

Figure 1-5 Standalone Gang8 (Gang Writer)

1.4 Ordering Information

Device name	ROM Size	RAM size	Package
MC80F7708AQ	8K bytes FLASH	256 bytes	44MQFP
MC80F7708AK	8K bytes FLASH	256 bytes	32SDIP
MC80F7708AD	8K bytes FLASH	256 bytes	32SOP

2. BLOCK DIAGRAM



*R24/AN3 and R25/AN5 are not supported in MC80F7708AK/MC80F7708AD(32pin).
 MC80F7708AQ : R20/AN0 ~ R25/AN5
 MC80F7708AK/MC80F7708AD : R20/AN0 ~ R23/AN3

3. PIN ASSIGNMENT

**44MQFP
(Top View)**

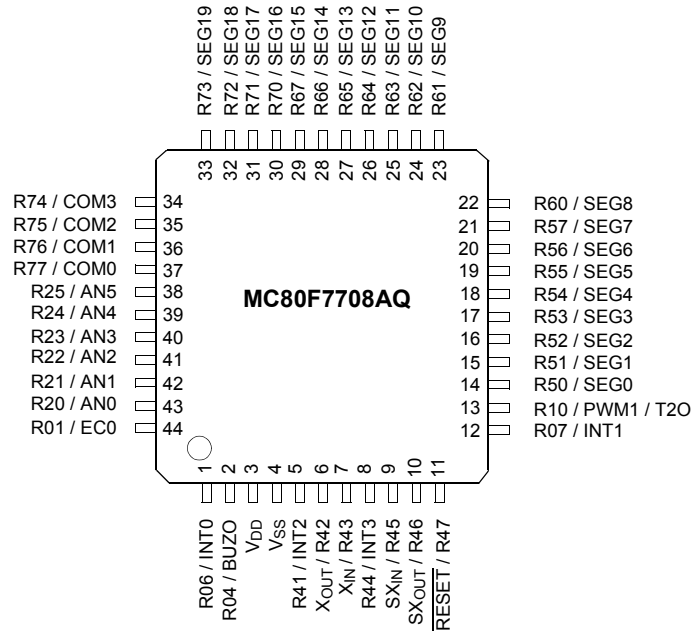

32SDIP/SOP

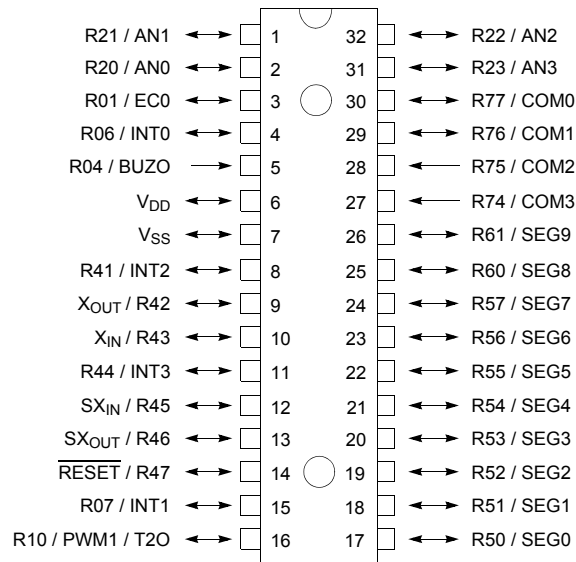

4. PACKAGE DIAGRAM

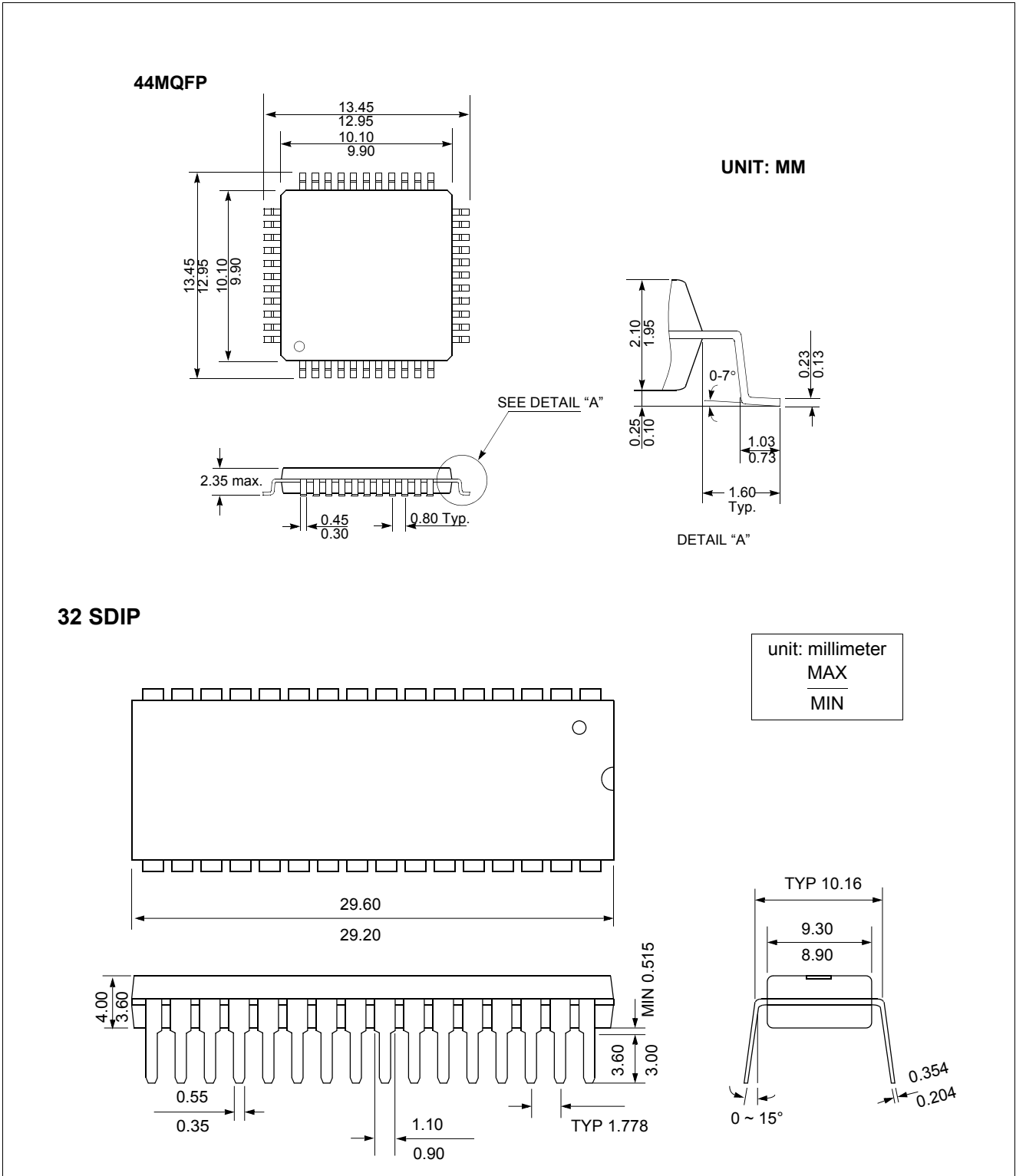

32 SOP

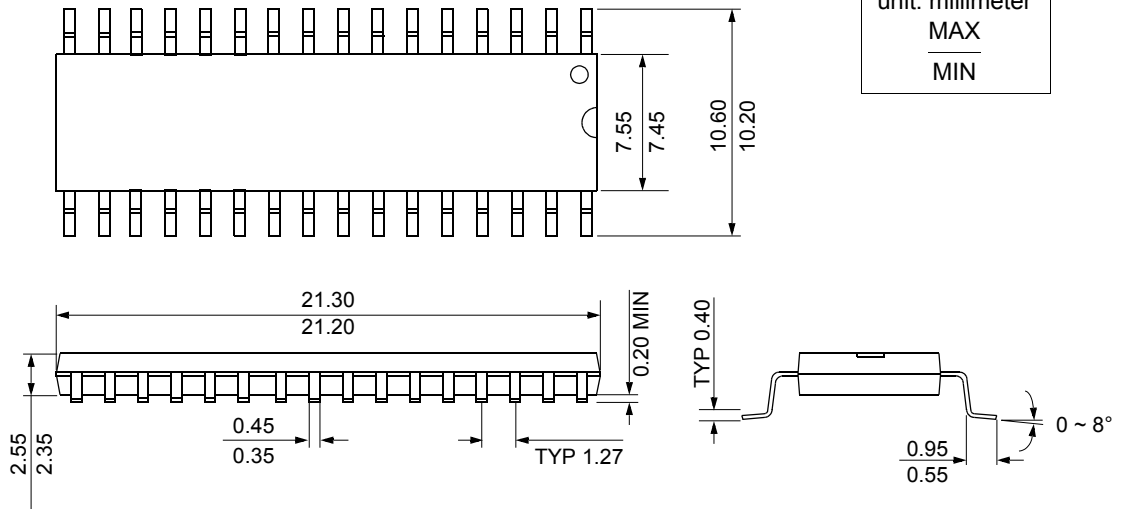

5. PIN FUNCTION

V_{DD}: Supply Voltage.

V_{SS}: Circuit ground.

RESET: Reset the MCU Reset.

X_{IN}: Input to the inverting oscillator amplifier and input to the internal main clock operating circuit.

X_{OUT}: Output from the inverting oscillator amplifier.

SX_{IN}: Input to the internal sub system clock operating circuit.

SX_{OUT}: Output from the inverting subsystem oscillator amplifier.

SEG0~SEG19: Segment signal output pins for the LCD display. See "18. LCD DRIVER" on page 78 for details. Also SEG0~SEG19 are shared with normal I/O ports.

COM0~COM3: Common signal output pins for the LCD display. See "18. LCD DRIVER" on page 78 for details. Also COM0~SEG3 are shared with normal I/O ports.

R01, R04, R06, R07: R0 is a 4-bit CMOS bidirectional I/O port. R0 pins 1 or 0 written to the Port Direction Register can be used as outputs or inputs. Also, pull-up resistors and open-drain outputs can be assigned by software.

In addition, R0 serves the functions of the various following special features.

Port pin	Alternate function
R01	EC0 (Timer 0 Event Count Input)
R04	BUZO (Buzzer Output)
R06	INT0 (External Interrupt 0 Request Input)
R07	INT1 (External Interrupt 1 Request input)

R10 : R1 is an 1-bit CMOS bidirectional I/O port. R1 pins 1 or 0 written to the Port Direction Register can be used as outputs or inputs or schmitt trigger inputs. Also, pull-up resistors and open-drain outputs can be assigned by software.

In addition, R1 serves the function of the following special feature.

Port pin	Alternate function
R10	PWM1/T2O (Timer3 PWM Output / Timer2 Output)

R20~R25: R2 is a 4/6-bit CMOS bidirectional I/O port. Each pins 1 or 0 written to the Port Direction Register can be used as outputs or inputs. Also, pull-up resistors and open-drain outputs can be assigned by software.

In addition, R2 serves the functions of the various following special features.

Port pin	Alternate function
R20	AN0 (Analog Input Port0)
R21	AN1 (Analog Input Port1)
R22	AN2 (Analog Input Port2)
R23	AN3 (Analog Input Port3)
R24	AN4 (Analog Input Port4)
R25	AN5 (Analog Input Port5)

Note: R24/AN3 and R25/AN5 are not supported in MC80F7708AK/AD(32pin).

R41~R47: R4 is a 7-bit CMOS bidirectional I/O port. Each pins 1 or 0 written to the Port Direction Register can be used as outputs or inputs. Also, pull-up resistors and open-drain outputs can be assigned by software.

In addition, R4 serves the functions of the various following special features.

Port pin	Alternate function
R41	INT2 (External Interrupt 2 Request input)
R42	X _{OUT}
R43	X _{IN}
R44	INT3 (External Interrupt 3 Request input)
R45	SX _{IN}
R46	SX _{OUT}
R47	RESET

R50~R57: R5 is an 8-bit CMOS bidirectional I/O port or LCD segment output. Each pins 1 or 0 written to the Port Direction Register can be used as outputs or inputs. And each pins can also be set in segment output mode in 1-bit units by R5PSR Register.

Port pin	Alternate function
R50	SEG0 (Segment Output 0)
R51	SEG1 (Segment Output 1)
R52	SEG2 (Segment Output 2)
R53	SEG3 (Segment Output 3)
R54	SEG4 (Segment Output 4)
R55	SEG5 (Segment Output 5)
R56	SEG6 (Segment Output 6)
R57	SEG7 (Segment Output 7)

R60~R67: R6 is an 8-bit CMOS bidirectional I/O port or LCD segment output. Each pins 1 or 0 written to the Port Direction Register can be used as outputs or inputs. And

each pins can also be set in segment output mode in 1-bit units by R6PSR Register.

Port pin	Alternate function
R60	SEG8 (Segment Output 8)
R61	SEG9 (Segment Output 9)
R62	SEG10 (Segment Output 10)
R63	SEG11 (Segment Output 11)
R64	SEG12 (Segment Output 12)
R65	SEG13 (Segment Output 13)
R66	SEG14 (Segment Output 14)
R67	SEG15 (Segment Output 15)

R70~R77: R7 is a 8-bit CMOS input port or LCD segment output. Each pins can be set in digital input or segment output mode in 1-bit units by R7PSR Register.

Port pin	Alternate function
R70	SEG16 (Segment Output 16)
R71	SEG17 (Segment Output 17)
R72	SEG18 (Segment Output 18)
R73	SEG19 (Segment Output 19)
R74	COM3 (Common Output 3)
R75	COM2 (Common Output 2)
R76	COM1 (Common Output 1)
R77	COM0 (Common Output 0)

PIN NAME	Pin No.		Primary Function		Secondary Function		State @ Reset	State @ STOP
	MC80F7708AQ	MC80F7708AK	I/O	Description	I/O	Description		
V _{DD}	3	6	-	Supply Voltage	-	-	-	-
V _{SS}	4	7	-	Circuit Ground	-	-	-	-
RESET / R47	11	14	I	Reset (low active)	-	-	'L' input	'H' input
X _{IN} /R43, X _{OUT} /R42	7,6	10,9	I,O	Main clock oscillator	-	-	Oscillation	'L', 'H'
SX _{IN} /R45, SX _{OUT} /R46	9,10	12,13	I,O	Sub clock oscillator	-	-	Oscillation	
R53/SEG3 ~ R57/SEG7	17~21	20~24	I/O	General I/O port	O	LCD segment output	Input port	State of before STOP
R60/SEG8 ~ R61/SEG9	22~23	25~26	I/O	General I/O port	O	LCD segment output		
R62/SEG10 ~ R67/SEG15	24~29	-	I/O	General I/O port	O	LCD segment output		
R70/SEG16 ~ R73/SEG19	30~33	-	I/O	General I/O ports	O	LCD segment output		
R74/COM3 ~ R77/COM0	34~37	27~30	I/O	General I/O ports	O	LCD common output		
R01/EC0	44	3	I/O	General I/O port	I	Event Counter Input		
R04/BUZO	2	5	I/O		O	Buzzer Output		
R06/INT0	1	4	I/O		I	Interrupt Input		
R07/INT1	12	15	I/O		I	Interrupt Input		
R10/PWM1/ T2O	13	16	I/O		O	Timer3 PWM Output Timer2 Output		
R20/AN0 ~ R23/AN3	43~40	2,1,32,31	I/O		I	A/D Converter Analog Input		
R24/AN4 ~ R25/AN5	39,38	-	I/O		I	A/D Converter Analog Input		
R50/SEG0	14	17	I/O	General I/O ports	O I	LCD Segment Output		
R51/SEG1	15	18	I/O	General I/O ports	O	LCD Segment Output		
R52/SEG2	16	19	I/O	General I/O ports	O	LCD Segment Output		

Table 5-1 Port Function Description

6. PORT STRUCTURES

R01/EC0, R06/INT0, R07/INT1, R41/IN2, R44/INT3

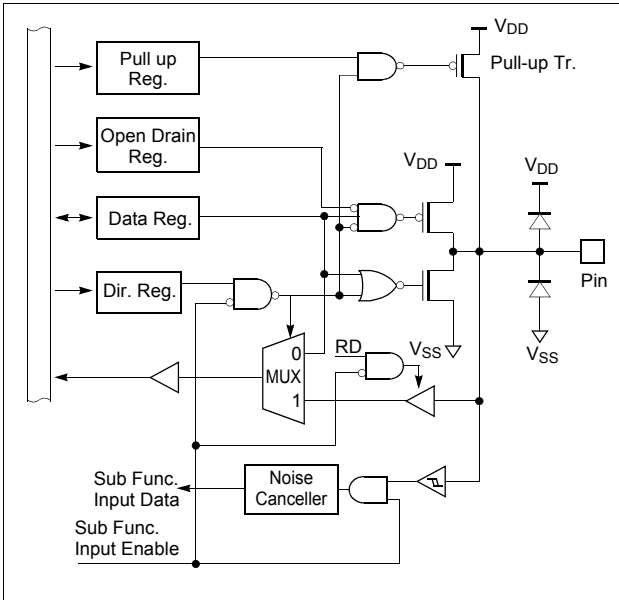

R20/AN0~R23/AN3, R24/AN4~R25/AN5

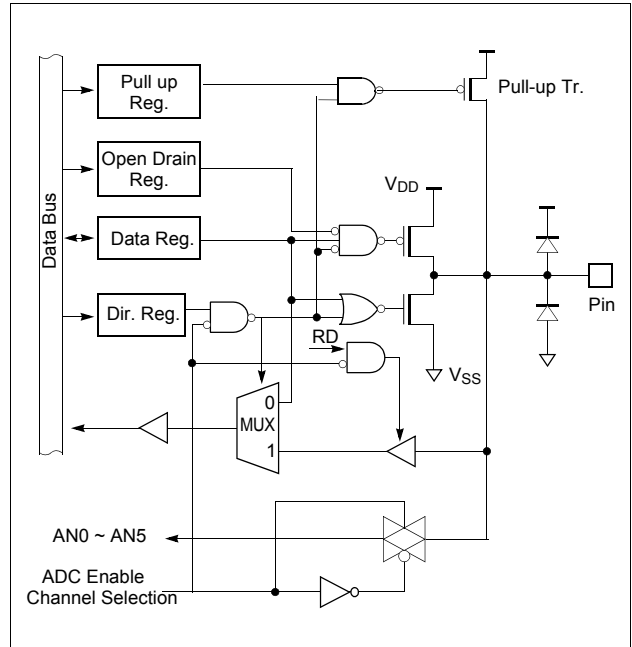

R04/BUZO, R10/PWM1/T20

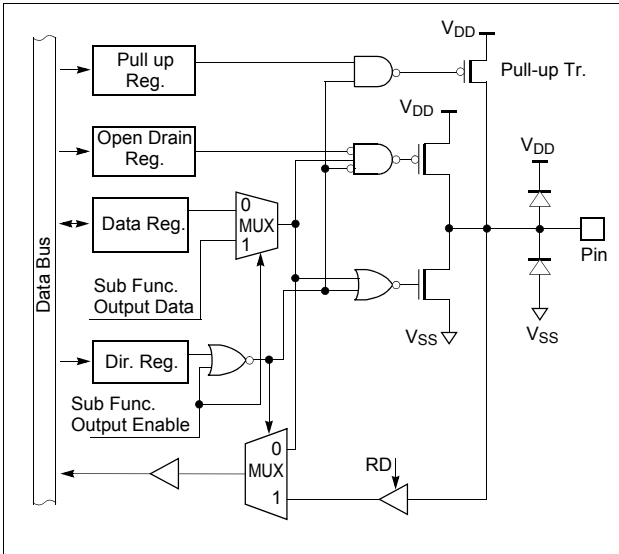

Note: R24/AN4 and R25/AN5 are available to MC80F7708AK/AD.

RESET(R47)

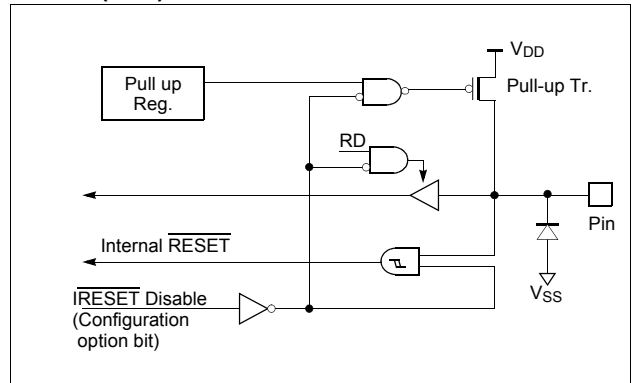

X_{IN}, X_{OUT} (Crystal or Ceramic resonator)

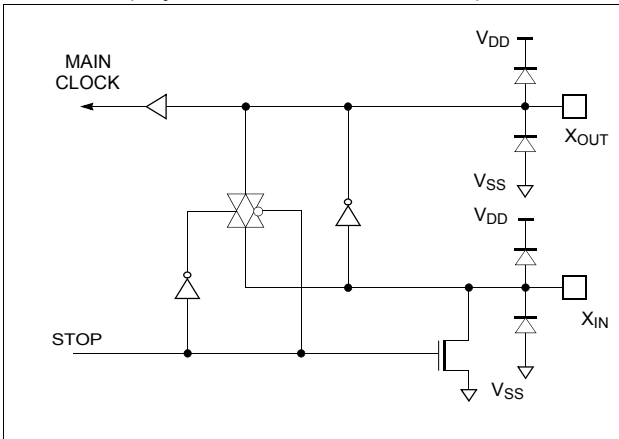

SX_{IN}, SX_{OUT}

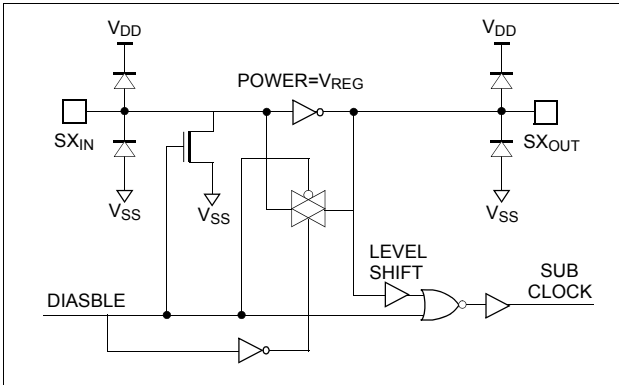

R43 (X_{IN}), R42 (X_{OUT})

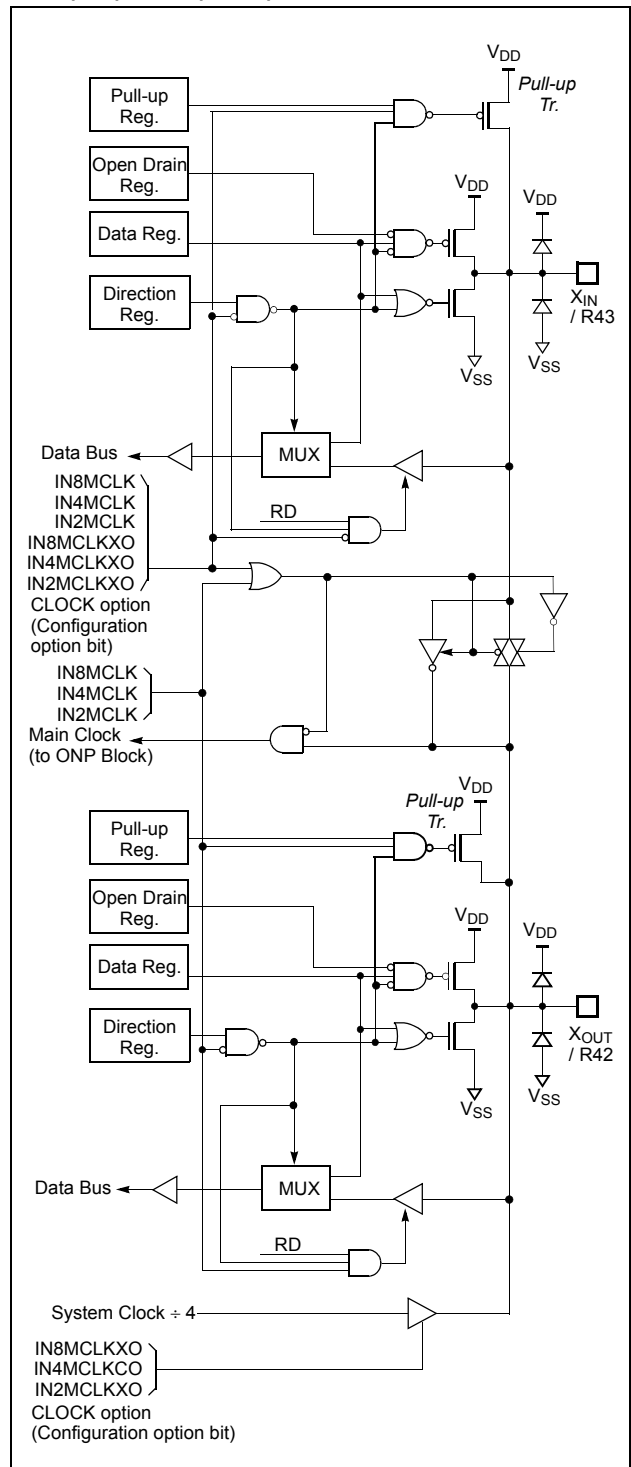

R53/SEG3~R57/SEG7, R60/SEG8~R67/SEG15

R70/SEG16~R70/SEG19

R74/COM3~R77/COM0

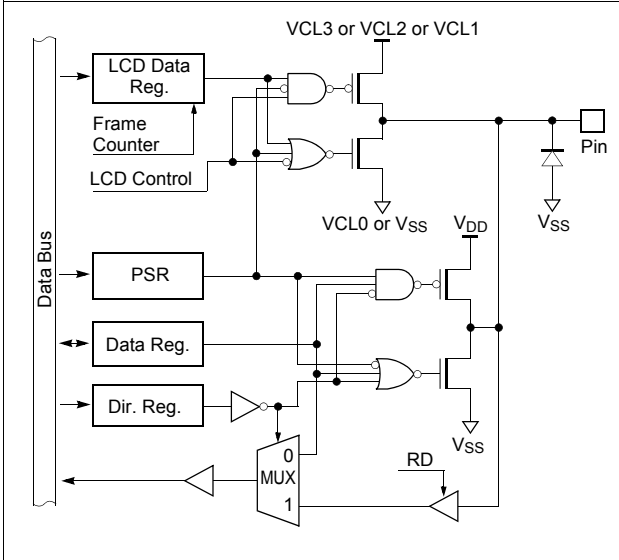

R50/SEG0, R52/SEG2

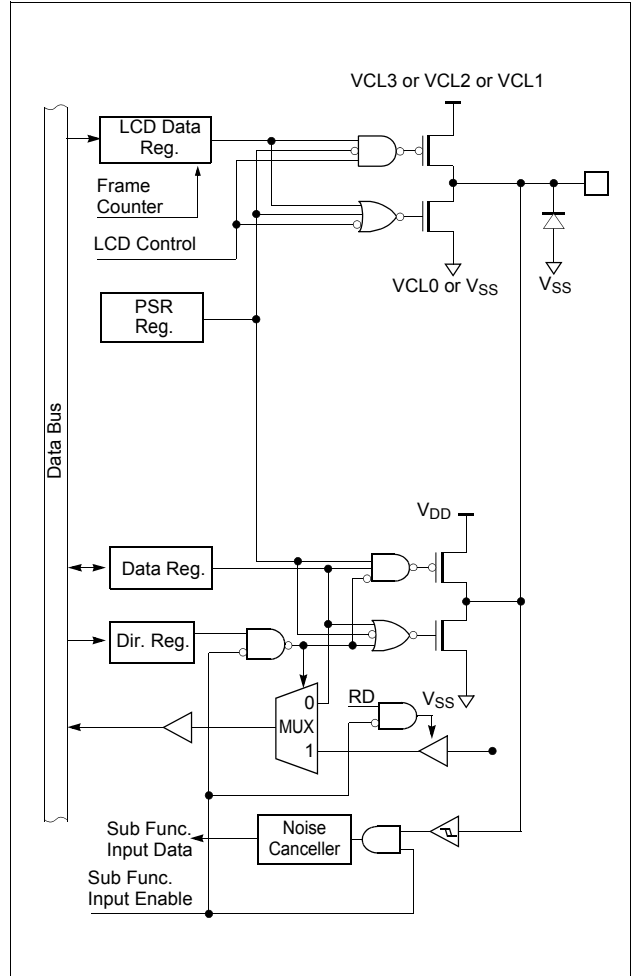

R51/SEG1

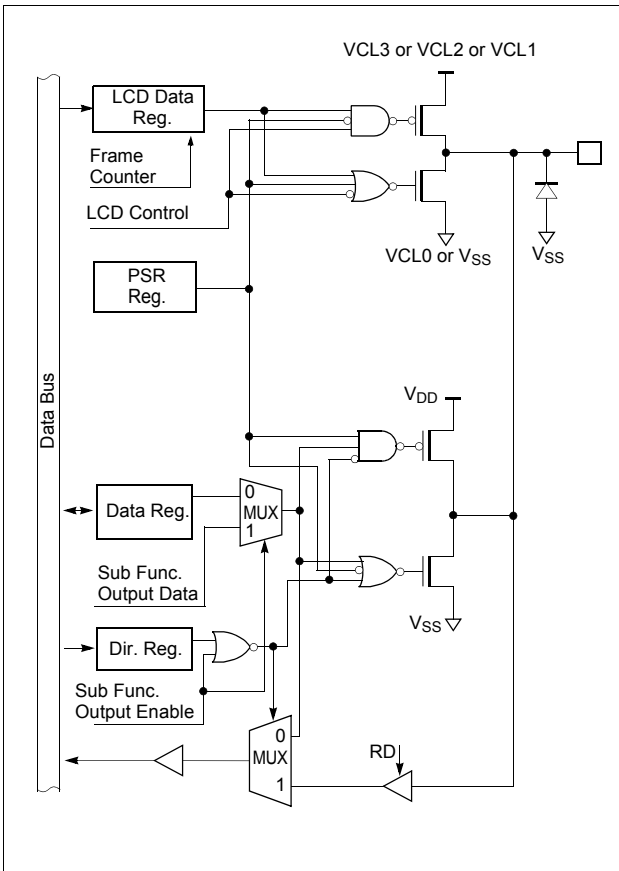

7. ELECTRICAL CHARACTERISTICS

7.1 Absolute Maximum Ratings

Supply voltage	-0.3 to +6.0 V
Storage Temperature	-45 to +125 °C
Voltage on any pin with respect to Ground (V_{SS})	-0.3 to $V_{DD}+0.3$
Maximum current sunk by (I_{OL} per I/O Pin)	20 mA
Maximum output current sourced by (I_{OH} per I/O Pin)	15 mA
Maximum current (ΣI_{OL})	100 mA

Maximum current (ΣI_{OH})..... 60 mA

Note: Stresses above those listed under “Absolute Maximum Ratings” may cause permanent damage to the device. This is a stress rating only and functional operation of the device at any other conditions above those indicated in the operational sections of this specification is not implied. Exposure to absolute maximum rating conditions for extended periods may affect device reliability.

7.2 Recommended Operating Conditions

Parameter	Symbol	Condition	Specifications			Unit
			Min.	Typ.	Max.	
Supply Voltage	V_{DD}	$f_{MAIN}=4MHz$	2.2	-	5.5	V
Main Operating Frequency	f_{MAIN}	$V_{DD}^1=2.2\sim 5.5V$	0.4	-	4.0	MHz
		$V_{DD}=4.5\sim 5.5V$	0.4	-	12.0	
	f_{SUB}	$V_{DD}=3.0\sim 5.5V$	-	32.768	-	kHz
Sub Operating Frequency	f_{SUB}	$V_{DD}=V_{DD}$	-	32.768	-	kHz
Operating Temperature	T_{OPR}		-40	-	85	°C

1. FLASH MCU Operating Voltage.

7.3 DC Electrical Characteristics

($T_A = -40 \sim 85^\circ\text{C}$, $V_{DD} = 2.2 \sim 5.5\text{V}$, $V_{SS} = 0\text{V}$)

Parameter	Symbol	Pin / Condition	Specifications			Unit
			Min.	Typ.	Max.	
Input High Voltage	V_{IH1}	R0~R7	$0.7V_{DD}$	-	$V_{DD}+0.3$	V
	V_{IH2}	$\overline{\text{RESET}}$, X_{IN} , SX_{IN} , INT0~3, EC0	$0.8V_{DD}$	-	$V_{DD}+0.3$	
Input Low Voltage	V_{IL1}	R0~R7	-0.3	-	$0.3V_{DD}$	V
	V_{IL2}	$\overline{\text{RESET}}$, X_{IN} , SX_{IN} , INT0~3, EC0	-0.3	-	$0.2V_{DD}$	
Output High Voltage	V_{OH1}	R0~R4 ($V_{DD}=4.5\text{V}$, $I_{OH1}=-1.6\text{mA}$)	$V_{DD}-0.3$	-	-	V
	V_{OH2}	R5~R7 ($V_{DD}=4.5\text{V}$, $I_{OH2}=-1.6\text{mA}$)	$V_{DD}-1.0$	-	-	
	V_{OH3}^1	SEG0~19, COM0~3 ($V_{DD}=4.5\text{V}$, $V_{CL3\sim 0}=3\text{V}$, $I_{OH3}=-15\mu\text{A}$)	$V_{CL3}-0.4$	-	-	
Output Low Voltage	V_{OL1}	R0~R4 ($V_{DD}=4.5\text{V}$, $I_{OL1}=1.6\text{mA}$)	-	-	0.35	V
	V_{OL2}	R5~R7 ($V_{DD}=4.5\text{V}$, $I_{OL2}=1.6\text{mA}$)			0.4	
	V_{OL3}^2	SEG0~19, COM0~3 ($V_{DD}=4.5\text{V}$, $V_{CL3\sim 0}=3\text{V}$, $I_{OL3}=15\mu\text{A}$)			0.12	
Input High Leakage Current	I_{IH}	All input pins including R5~R7 ($V_{IN}=V_{DD}$)	-	-	1	μA
Input Low Leakage Current	I_{IL}	All input pins including R5~R7 ($V_{IN}=V_{SS}$)	-1	-	-	
LVR (Low Voltage Reset)	V_{LVR}	SVLD[2:0]=001	TBD	2.4	TBD	V
		SVLD[2:0]=010	TBD	2.7	TBD	
		SVLD[2:0]=011	TBD	3.0	TBD	
		SVLD[2:0]=100	TBD	3.9	TBD	
Power Supply Voltage rising time	T_R	$V_{DD}=5\text{V}$ ($4\mu\text{S}/\text{V}$)	20	-	-	μS
LVR Circuit Current consumption	I_{LVR}	$V_{DD}=5\text{V}$	-	3	-	μA
POR(Power on Reset) Level	V_{POR}	V_{DD} ($T_A=25^\circ\text{C}$)	2.4	2.7	2.8	V
			1.7	1.9	2.1	
POR Start Voltage ³	V_{START}	V_{DD} ($T_A=25^\circ\text{C}$)			1.8	V
POR Rising Time ³	T_{POR}	V_{DD} ($T_A=25^\circ\text{C}$)			40	ms/V
VDD rising Time ³	T_{VDD}	V_{DD} ($T_A=25^\circ\text{C}$)			40	ms/V
Hysteresis	$V_{T+} \sim V_{T-}$	$\overline{\text{RESET}}$, INT0~3, EC0 ($V_{DD}=5\text{V}$)	$0.2V_{DD}$	-	$0.8V_{DD}$	V
Pull-up Current	I_{PU}	R0~R4 ($V_{DD}=3.0\text{V}$, $V_{PIN}=0\text{V}$)	20	-	60	μA
Current dissipation in active mode ⁴	I_{DD}	V_{DD} ($f_{MAIN}=12\text{MHz}$, $V_{DD}=5.5\text{V}$, $f_{SUB}=0$)	-	5	15	mA
Current dissipation in sleep mode ⁵	I_{SLEEP}	V_{DD} ($f_{MAIN}=12\text{MHz}$, $V_{DD}=5.5\text{V}$, $f_{SUB}=0$)	-	2	4	
Current dissipation in sub active mode ⁶	$I_{subactive}$	$f_{MAIN}=\text{off}$, $V_{DD}=3\text{V}$, $f_{SUB}=32.768\text{kHz}$	-	35	50	μA
	$I_{subsleep}$	$f_{MAIN}=\text{off}$, $V_{DD}=3\text{V}$, $f_{SUB}=32.768\text{kHz}$		7	14	μA

Parameter	Symbol	Pin / Condition	Specifications			Unit
			Min.	Typ.	Max.	
Current dissipation in stop mode	I _{STOP}	f _{MAIN} =off, V _{DD} =5.5V, f _{SUB} =0	-	3	7	μA
	I _{SUB}	f _{MAIN} =off, V _{DD} =5.5V, f _{SUB} =32.768kHz		10	TBD	uA
Internal 8MHz Oscillation Frequency	f _{IN8M}	V _{DD} =5V, T _A =25°C	TBD	8	TBD	MHz
Internal 4MHz Oscillation Frequency	f _{IN4M}	V _{DD} =5V, T _A =25°C	TBD	4	TBD	MHz
Internal 2MHz Oscillation Frequency	f _{IN2M}	V _{DD} =5V, T _A =25°C	TBD	2	TBD	MHz

1. V_{OH3} is the voltage when VCL3, VCL2, VCL1 and VCL0 are supplied at pads.
2. V_{OL3} is the voltage when V_{SS} is supplied at pad.
3. These parameters are presented for design guidance only and not tested or guaranteed.
4. Current dissipation is proportioned according to operation voltage and frequency.
5. In sleep mode, oscillation continues and peripherals are operated normally but internal CPU clock stops.
6. In sub sleep mode, sub oscillation continues and peripherals are operated normally but internal CPU clock stops.

7.4 LCD Characteristics

(T_A= -40~85°C, V_{DD}=2.2~5.5V, V_{SS}=0V)

Parameter	Symbol	Condition	Specifications			Unit
			Min.	Typ.	Max.	
LCD Common Output Current	I _{COM}	Output Voltage Deviation=0.2V	30	-	-	μA
LCD Segment Output Current	I _{SEG}	Output Voltage Deviation=0.2V	5	-	-	

7.5 A/D Converter Characteristics

(T_A=-40~85°C, AV_{DD}=V_{DD}=5.12V,2.56, V_{SS}=0V)

Parameter	Symbol	Condition	Specifications			Unit
			Min.	Typ.	Max.	
Analog Power Supply Input Voltage Range	AV _{DD}	-	V _{DD}	-	V _{DD}	V
Analog Input Voltage Range	V _{AN}	-	V _{SS} -0.3	-	AV _{DD} +0.3	
Current Following Between AV _{DD} and AV _{SS}	I _{AVDD}	-	-	-	200	μA
Overall Accuracy	CAIN	-	-	±1.0	±2.0	LSB
Non Linearity Error	NNLE	-	-	±1.0	±2.0	
Differential Non Linearity Error	NDNLE	-	-	±1.0	±2.0	
Zero Offset Error	NZOE	-	-	±0.5	±1.5	
Full Scale Error	NFSE	-	-	±0.25	±0.5	
Gain Error	NGE	-	-	±1.0	±1.5	
Conversion Time	TCONV	f _{MAIN} =8MHz	-	-	10	μS
		f _{MAIN} =4MHz	-	-	20	

7.6 AC Characteristics

(TA=25°C, V_{DD}=4V, AV_{DD}=4V, V_{SS}=AV_{SS}=0V)

Parameter	Symbol	Pins	Specifications			Unit
			Min.	Typ.	Max.	
Main Operating Frequency	f _{MCP}	X _{IN}	0.4	-	12	MHz
Sub Operating Frequency	f _{SCP}	SX _{IN}	30	32.768	35	kHz
System Clock Frequency ¹	t _{SYS}	-	166	-	5000	nS
Main Oscillation Stabilization Time (4MHz)	t _{MST}	X _{IN} , X _{OUT}	-	-	20	mS
Sub Oscillation Stabilization Time	t _{SST}	SX _{IN} , SX _{OUT}	-	1	2	S
External Clock "H" or "L" Pulse Width	t _{MCPW}	X _{IN}	35	-	-	nS
	t _{SCPW}	SX _{IN}	5	-	-	μS
External Clock Transition Time	t _{RCP} , t _{FCP}	X _{IN}	-	-	20	nS
Interrupt Pulse Width	t _{IW}	INT0, INT1, INT2, IN3	2	-	-	t _{sys}
RESET Input Pulse "L" Width	t _{RST}	RESET	8	-	-	t _{sys}
Event Counter Input "H" or "L" Pulse Width	t _{ECW}	EC0	2	-	-	t _{sys}
Event Counter Transition Time	t _{REC} , t _{FEC}	EC0	-	-	20	nS

1.SCMR=XXXX000X_B that is f_{MAIN}÷2

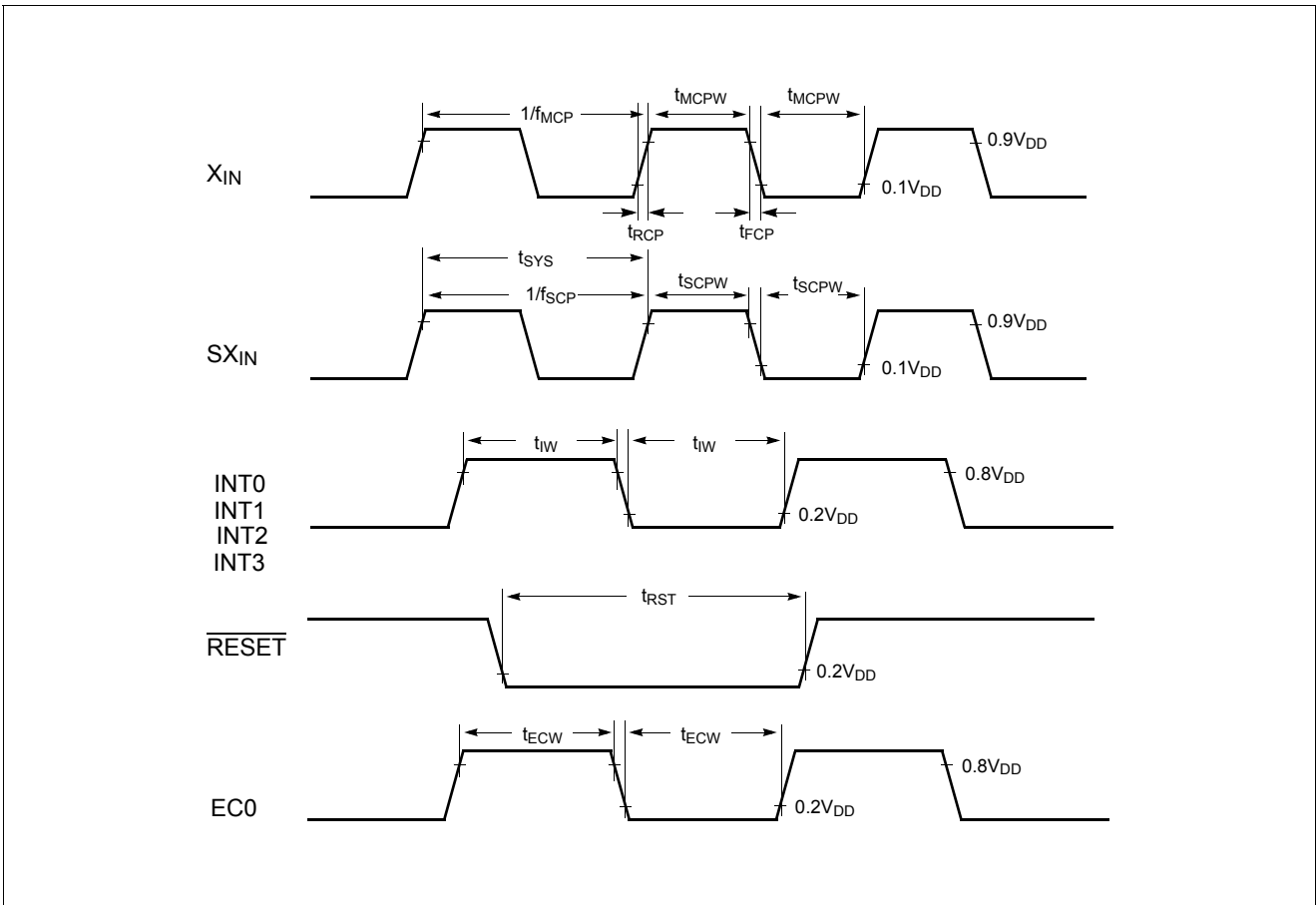

Figure 7-1 AC Timing Chart

7.7 Typical Characteristics

These graphs and tables are for design guidance only and are not tested or guaranteed.

In some graphs or tables, the data presented are outside specified operating range (e.g. outside specified V_{DD} range). This is for information only and devices are guaranteed to operate properly only within the specified range.

The data is a statistical summary of data collected on units from different lots over a period of time. “Typical” repre-

sents the mean of the distribution while “max” or “min” represents $(\text{mean} + 3\sigma)$ and $(\text{mean} - 3\sigma)$ respectively where σ is standard deviation

8. MEMORY ORGANIZATION

The have separate address spaces for Program memory, Data Memory and Display memory. Program memory can only be read, not written to. It can be up to 8K bytes of Pro-

8.1 Registers

This device has six registers that are the Program Counter (PC), a Accumulator (A), two index registers (X, Y), the Stack Pointer (SP), and the Program Status Word (PSW). The Program Counter consists of 16-bit register.

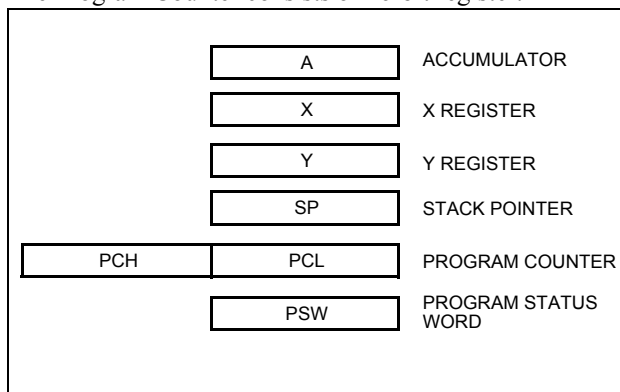

Figure 8-1 Configuration of Registers

Accumulator: The Accumulator is the 8-bit general purpose register, used for data operation such as transfer, temporary saving, and conditional judgement, etc.

The Accumulator can be used as a 16-bit register with Y Register as shown below.

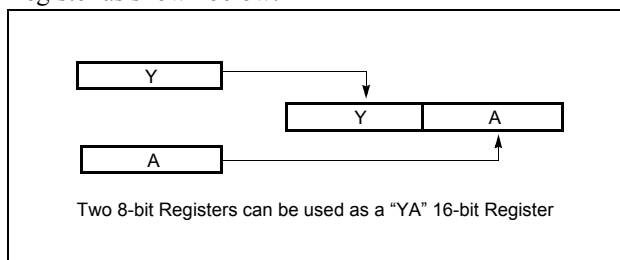

Figure 8-2 Configuration of YA 16-bit Register

X, Y Registers: In the addressing mode which uses these index registers, the register contents are added to the specified address, which becomes the actual address. These modes are extremely effective for referencing subroutine tables and memory tables. The index registers also have increment, decrement, comparison and data transfer functions, and they can be used as simple accumulators.

Stack Pointer: The Stack Pointer is an 8-bit register used for occurrence interrupts and calling out subroutines. Stack Pointer identifies the location in the stack to be accessed (save or restore).

gram memory. Data memory can be read and written to up to 1024 bytes including the stack area. Display memory has prepared 27 nibbles for LCD.

Generally, SP is automatically updated when a subroutine call is executed or an interrupt is accepted. However, if it is used in excess of the stack area permitted by the data memory allocating configuration, the user-processed data may be lost.

The stack can be located at any position within 100_H to 15F_H of the internal data memory. The SP is not initialized by hardware, requiring to write the initial value (the location with which the use of the stack starts) by using the initialization routine. Normally, the initial value of "15F_H" is used.

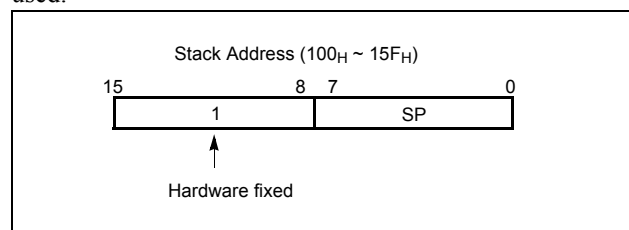

Caution:

The Stack Pointer must be initialized by software because its value is undefined after RESET.

Example: To initialize the SP

```
LDX #05FH ;
TXSP ; SP ← 05FH
```

Program Counter: The Program Counter is a 16-bit wide which consists of two 8-bit registers, PCH and PCL. This counter indicates the address of the next instruction to be executed. In reset state, the program counter has reset routine address (PCH:0FF_H, PCL:0FE_H).

Program Status Word: The Program Status Word (PSW) contains several bits that reflect the current state of the CPU. The PSW is described in Figure 8-3. It contains the Negative flag, the Overflow flag, the Break flag the Half Carry (for BCD operation), the Interrupt enable flag, the Zero flag, and the Carry flag.

[Carry flag C]

This flag stores any carry or borrow from the ALU of CPU after an arithmetic operation and is also changed by the Shift Instruction or Rotate Instruction.

[Zero flag Z]

This flag is set when the result of an arithmetic operation or data transfer is “0” and is cleared by any other result.

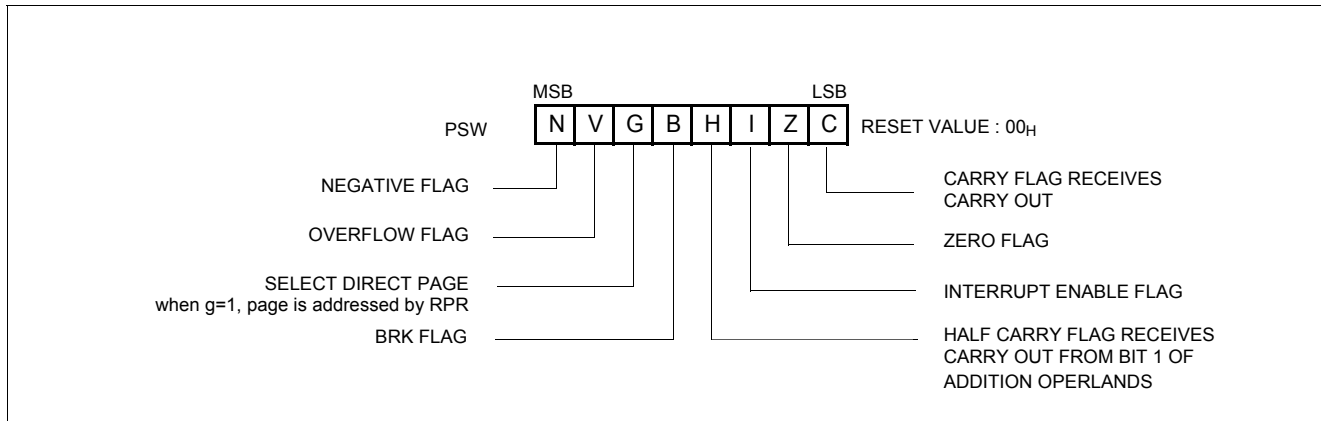

Figure 8-3 PSW (Program Status Word) Register

[Interrupt disable flag I]

This flag enables/disables all interrupts except interrupt caused by Reset or software BRK instruction. All interrupts are disabled when cleared to “0”. This flag immediately becomes “0” when an interrupt is served. It is set by the EI instruction and cleared by the DI instruction.

[Half carry flag H]

After operation, this is set when there is a carry from bit 3 of ALU or there is no borrow from bit 4 of ALU. This bit can not be set or cleared except CLRV instruction with Overflow flag (V).

[Break flag B]

This flag is set by software BRK instruction to distinguish BRK from TCALL instruction with the same vector address.

[Direct page flag G]

This flag assigns RAM page for direct addressing mode. In

the direct addressing mode, addressing area is from zero page 00H to 0FFH when this flag is "0". If it is set to "1", addressing area is assigned by RPR register (address 0F3H). It is set by SETG instruction and cleared by CLRG.

[Overflow flag V]

This flag is set to “1” when an overflow occurs as the result of an arithmetic operation involving signs. An overflow occurs when the result of an addition or subtraction exceeds +127 (7FH) or -128 (80H). The CLR V instruction clears the overflow flag. There is no set instruction. When the BIT instruction is executed, bit 6 of memory is copied to this flag.

[Negative flag N]

This flag is set to match the sign bit (bit 7) status of the result of a data or arithmetic operation. When the BIT instruction is executed, bit 7 of memory is copied to this flag.

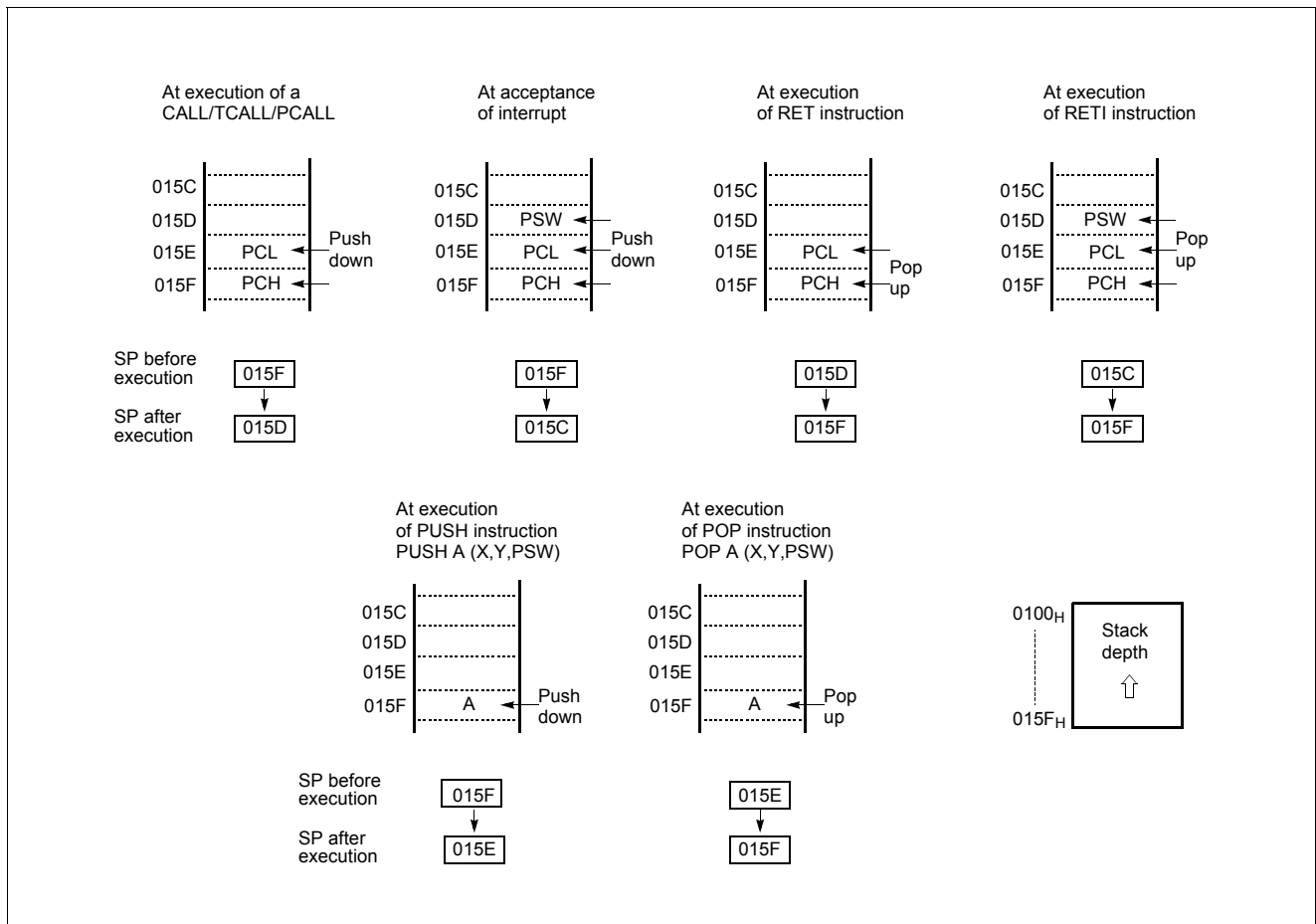

Figure 8-4 Stack Operation

8.2 Program Memory

A 16-bit program counter is capable of addressing up to 64K bytes, but this device has 8K bytes program memory space only physically implemented. Accessing a location above FFFF_H will cause a wrap-around to 0000_H.

Figure 8-5 shows a map of Program Memory. After reset, the CPU begins execution from reset vector which is stored in address FFFE_H and FFFF_H as shown in Figure 8-6.

As shown in Figure 8-5, each area is assigned a fixed location in Program Memory. Program Memory area contains the user program.

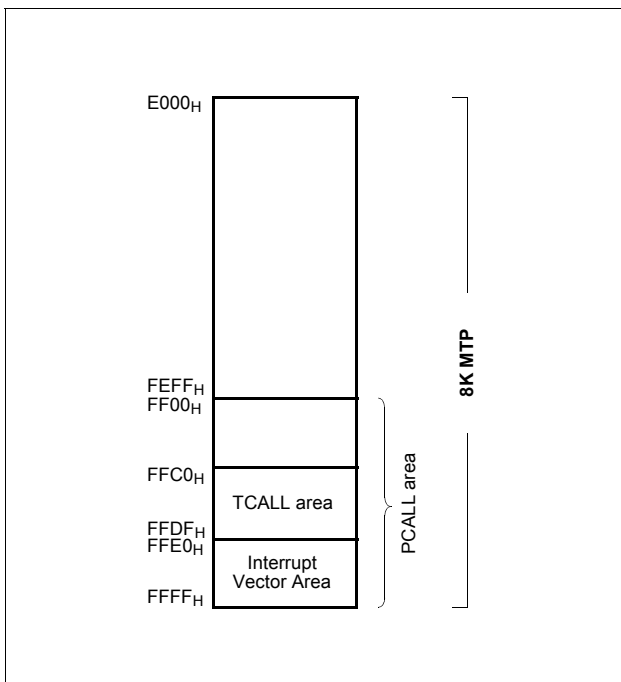

Figure 8-5 Program Memory Map

Page Call (PCALL) area contains subroutine program to reduce program byte length by using 2 bytes PCALL instead of 3 bytes CALL instruction. If it is frequently called, it is more useful to save program byte length.

Table Call (TCALL) causes the CPU to jump to each TCALL address, where it commences the execution of the service routine. The Table Call service area spaces 2-byte for every TCALL: 0FFC0_H for TCALL15, 0FFC2_H for TCALL14, etc., as shown in Figure 8-7.

Example: Usage of TCALL

```

LDA    #5
      TCALL 0FH           ; 1BYTE INSTRUCTION
      :                ; INSTEAD OF 2 BYTES
      :                ; NORMAL CALL
;
; TABLE CALL ROUTINE
;
FUNC_A: LDA    LRG0
      RET
;
FUNC_B: LDA    LRG1
      RET
;
; TABLE CALL ADD. AREA
;
      ORG    0FFC0H       ; TCALL ADDRESS AREA
      DW    FUNC_A
      DW    FUNC_B
    
```

The interrupt causes the CPU to jump to specific location, where it commences the execution of the service routine. The External interrupt 0, for example, is assigned to location 0FFFA_H. The interrupt service locations spaces 2-byte interval: 0FFF8_H and 0FFF9_H for External Interrupt 1, 0FFFA_H and 0FFFB_H for External Interrupt 0, etc.

Any area from 0FF00_H to 0FFFF_H, if it is not going to be used, its service location is available as general purpose Program Memory.

Address	Vector Area Memory
0FFE0 _H	Watch Timer interrupt Vector Area
	Watch dog timer interrupt Vector
E2	Basic Interval Timer Interrupt Vector Area
E4	-
E6	-
E8	Timer/Counter 3 Interrupt Vector Area
EA	Timer/Counter 2 Interrupt Vector Area
EC	Timer/Counter 1 Interrupt Vector Area
EE	Timer/Counter 0 Interrupt Vector Area
F0	-
F2	-
F4	External Interrupt 3 Vector Area
F6	External Interrupt 2 Vector Area
F8	External Interrupt 1 Vector Area
FA	External Interrupt 0 Vector Area
FC	-
FE	Reset Interrupt Vector Area

Figure 8-6 Interrupt Vector Area

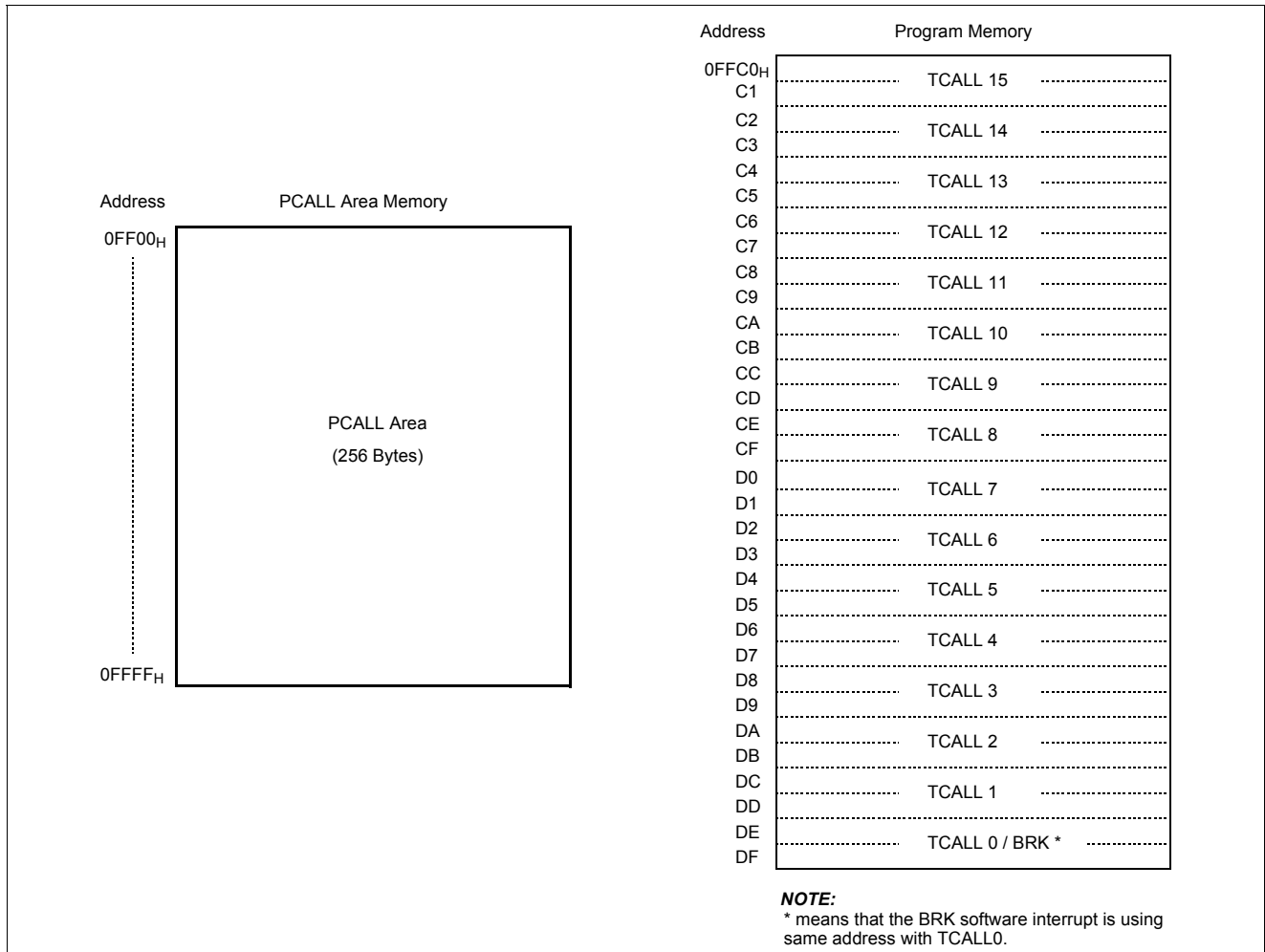
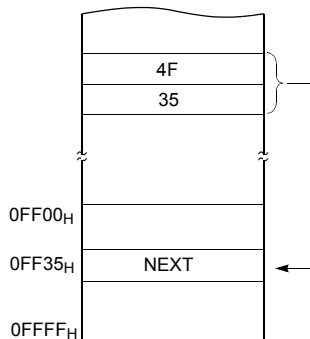

Figure 8-7 PCALL and TCALL Memory Area

PCALL → rel

4F35 PCALL 35_H



TCALL → n

4A TCALL 4

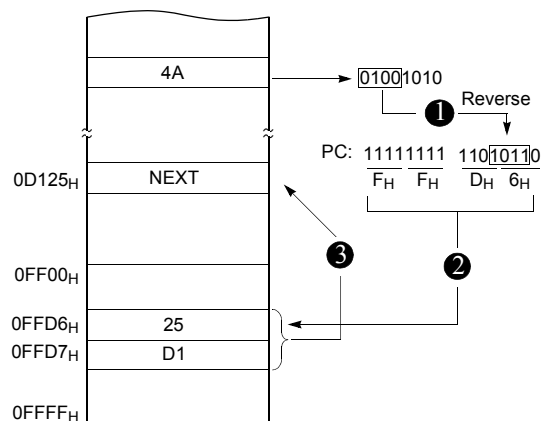

Example: The usage software example of Vector address and the initialize part.

```

ORG 0FFE0H; Device : MC807708A

DW WT_INT      ; Watch Timer / Watch Dog Timer
DW BIT_INT     ; Basic Interval Timer
DW NOT_USED    ; NOT_USED
DW NOT_USED    ; Not_Used
DW TMR3_INT    ; Timer-3
DW TMR2_INT    ; Timer-2
DW TMR1_INT    ; Timer-1
DW TMR0_INT    ; Timer-0
DW NOT_USED    ; Not Used
DW NOT_USED    ; Not Used
DW EX3_INT     ; INT.3
DW EX2_INT     ; INT.2
DW EX1_INT     ; Int.1
DW EX0_INT     ; Int.0
DW NOT_USED    ; Not used
DW RESET      ; Reset

;*****
;          MAIN      PROGRAM          *
;*****

ORG 0E000H

RESET:  DI          ;Disable All Interrupts
        CLRG
        LDX #0
        LDA #0
RAM_CLR1: STA {X}+      ;Page0 RAM Clear(!0000H->!009FH)
        CMPX #0A0H
        BNE RAM_CLR1

        LDM RPR,#0000_0001B;Page1 RAM Clear(!0100H->!015FH)
        SETG
        LDX #0
        LDA #0
RAM_CLR2: STA {X}+
        CMPX #060H
        BNE RAM_CLR2
        CLRG

        LDX #05FH      ;Stack Pointer Initialize
        TXSP

        LDM RPR,#0000_0000B;Page0 selection
        CALL LCD_CLR      ;Clear LCD display memory

        LDM R0, #0      ;Normal Port 0
        LDM R0IO,#1000_0010B;Normal Port Direction
        LDM R0PU,#1000_0010B;Pull Up Selection Set
        LDM R0OD,#0000_0001B;R0 port Open Drain control
        :
        :
        LDM SCMR,#1111_0000B;System clock control
        :
        :

```

8.3 Data Memory

Figure 8-8 shows the internal Data Memory space available. Data Memory is divided into four groups, a user RAM, control registers, Stack, and LCD memory.

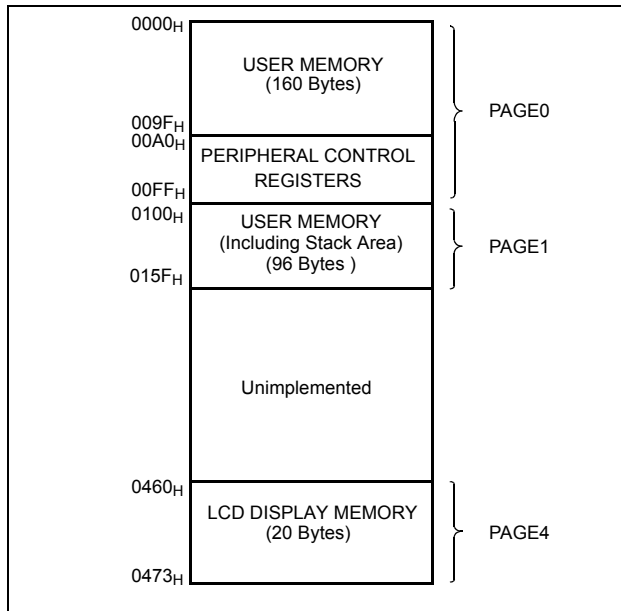

Figure 8-8 Data Memory Map

User Memory

The MC80F7708A have 256×8 bits for the user data memory (RAM). There are three pages internal RAM. Page is selected by G-flag and RAM page selection register RPR. When G-flag is cleared to “0”, always page 0 is selected regardless of RPR value. If G-flag is set to “1”, page will be selected according to RPR value.

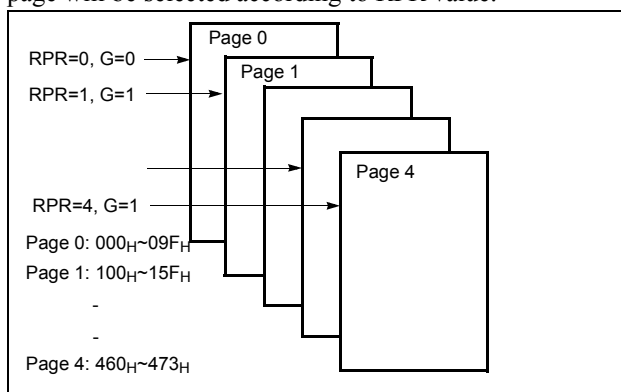
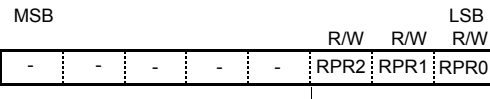

Figure 8-9 RAM page configuration

RPR (RAM Page Selection Register)

ADDRESS: 0CF_H
INITIAL VALUE: ----_001_B



RPR[2:0] (RAM Page Selection)

RPR2	RPR1	RPR0	RAM Page Selection
0	0	0	PAGE 0
0	0	1	PAGE 1
0	1	0	-
0	1	1	-
1	0	0	PAGE 4
1	0	1	-
1	1	0	-
1	1	1	-

Caution1 : After setting RPR, be sure to execute SETG instruction.
Caution2 : When executing CLRG instruction, be selected PAGE0 regardless of RPR.

Figure 8-10 RAM Page Selection Register

Control Registers

The control registers are used by the CPU and Peripheral function blocks for controlling the desired operation of the device. Therefore these registers contain control and status bits for the interrupt system, the timer/counters, analog to digital converters and I/O ports. The control registers are in address range of 0A0_H to 0FF_H.

Note that unoccupied addresses may not be implemented on the chip. Read accesses to these addresses will in general return random data, and write accesses will have an indeterminate effect.

More detailed informations of each register are explained in each peripheral section.

Note: Write only registers can not be accessed by bit manipulation instruction. Do not use read-modify-write instruction. Use byte manipulation instruction.

Example; To write at CKCTRL

```
LDM CKCTRL, #05H ;Divide ratio +8
```

Stack Area

The stack provides the area where the return address is saved before a jump is performed during the processing

routine at the execution of a subroutine call instruction or the acceptance of an interrupt.

When returning from the processing routine, executing the subroutine return instruction [RET] restores the contents of the program counter from the stack; executing the interrupt return instruction [RETI] restores the contents of the program counter and flags.

The save/restore locations in the stack are determined by

the stack pointer (SP). The SP is automatically decreased after the saving, and increased before the restoring. This means the value of the SP indicates the stack location number for the next save. Refer to Figure 8-4 on page 24.

LCD Display Memory

LCD display data area is handled in LCD section.

See "18.3 LCD Display Memory" on page 82.

Address	Register Name	Symbol	R/W	Initial Value								Addressing Mode
				7	6	5	4	3	2	1	0	
00A0H	R0 Open Drain Control Register	R0OD	W	0	0	-	0	-	-	0	-	byte ¹
00A1H	R1 Open Drain Control Register	R1OD	W	-	-	-	-	-	-	-	0	byte
00A2H	R2Open Drain Control Register	R2OD	W	-	-	0	0	0	0	0	0	byte
00A4H	R4Open Drain Control Register	R4OD	W	-	0	0	0	0	0	0	-	byte
00A5H	R0 Pull-up Register	R0PU	W	0	0	-	0	-	-	0	-	byte
00A6H	R1 Pull-up Register	R1PU	W	-	-	-	-	-	-	-	0	byte
00A7H	R2 Pull-up Register	R2PU	W	-	-	0	0	0	0	0	0	byte
00A9H	R4 Pull-up Register	R2PU	W	0	0	0	0	0	0	0	-	byte
00AAH	Port Selection Register 0	PSR0	W	0	0	-	0	-	-	0	-	byte
00ABH	Port Selection Register 1	PSR1	W	-	-	-	-	-	0	0	0	byte
00ACH	R5 Port Selection Register	R5PSR	R / W	1	1	1	1	1	1	1	1	byte, bit ²
00ADH	R6 Port Selection Register	R6PSR	R / W	1	1	1	1	1	1	1	1	byte, bit
00AEH	R7 Port Selection Register	R7PSR	R / W	1	1	1	1	1	1	1	1	byte, bit
00B0H	R7 Data Register	R7	R / W	0	0	0	0	0	0	0	0	byte
00B2H	LCD Control Register	LCR	R / W	0	0	0	0	0	0	0	0	byte, bit
00B3H	LCD BIAS Control Register	LBCR	R / W	0	1	1	1	1	0	0	0	byte, bit
00B4H	R7 Direction Register	R7IO	W	0	0	0	0	0	0	0	0	byte
00B8H	-	ASIMR0	R / W	0	0	0	0	-	0	0	-	byte, bit
00B9H	-	ASISR0	R	-	-	-	-	-	0	0	0	byte
00BAH	-	BRGCR0	R / W	-	0	0	1	0	0	0	0	byte, bit
00BBH	-	RXBR0	R	0	0	0	0	0	0	0	0	byte
	-	TXSR0	W	1	1	1	1	1	1	1	1	byte
00C0H	R0 port data register	R0	R / W	0	0	-	0	-	-	0	-	byte, bit
00C1H	R0 Direction Register	R0IO	W	0	0	-	0	-	-	0	-	byte
00C2H	R1 port data register	R1	R / W	-	-	-	-	-	-	-	0	byte, bit
00C3H	R1 Direction Register	R1IO	W	-	-	-	-	-	-	-	0	byte
00C4H	R2 port data register	R2	R / W	-	-	0	0	0	0	0	0	byte, bit
00C5H	R2 Direction Register	R2IO	W	-	-	0	0	0	0	0	0	byte
00C8H	R4 port data register	R2	R / W	-	0	0	0	0	0	0	-	byte, bit

Table 8-1 Control Registers

Address	Register Name	Symbol	R/W	Initial Value								Addressing Mode	
				7	6	5	4	3	2	1	0		
00C9H	R4 Direction Register	R4IO	W	-	0	0	0	0	0	0	0	-	byte
00CAH	R5 port data register	R5	R/W	0	0	0	0	0	0	0	0	0	byte, bit
00CBH	R5 Direction Register	R5IO	W	0	0	0	0	0	0	0	0	0	byte
00CCH	R6 port data register	R6	R/W	0	0	0	0	0	0	0	0	0	byte, bit
00CDH	R6 Direction Register	R6IO	W	0	0	0	0	0	0	0	0	0	byte
00CEH	Buzzer Driver Register	BUZR	W	1	1	1	1	1	1	1	1	1	byte
00CFH	Ram Page Selection Register	RPR	R / W	-	-	-	-	-	0	0	1		byte, bit
00D0H	Timer 0 Mode Control Register	TM0	R / W	-	-	0	0	0	0	0	0	0	byte, bit
00D1H	Timer 0 Register	T0	R	0	0	0	0	0	0	0	0	0	byte
	Timer 0 Data Register	TDR0	W	1	1	1	1	1	1	1	1	1	byte
	Timer 0 Capture Data Register	CDR0	R	0	0	0	0	0	0	0	0	0	byte
00D2H	Timer 1 Mode Control Register	TM1	R / W	0	0	-	0	0	0	0	0	0	byte, bit
00D3H	Timer 1 Data Register	TDR1	W	1	1	1	1	1	1	1	1	1	byte
00D4H	Timer 1 Register	T1	R	0	0	0	0	0	0	0	0	0	byte
	Timer 1 Capture Data Register	CDR1	R	0	0	0	0	0	0	0	0	0	byte
00D6H	Timer 2 Mode Control Register	TM2	R / W	-	-	0	0	0	0	0	0	0	byte, bit
00D7H	Timer 2 Register	T2	R	0	0	0	0	0	0	0	0	0	byte
	Timer 2 Data Register	TDR2	W	1	1	1	1	1	1	1	1	1	byte
	Timer 2 Capture data Register	CDR2	R	0	0	0	0	0	0	0	0	0	byte
00D8H	Timer 3 Mode Control Register	TM3	R / W	0	0	0	0	0	0	0	0	0	byte, bit
00D9H	Timer 3 Data Register	TDR3	W	1	1	1	1	1	1	1	1	1	byte
	Timer 3 PWM Period Register	T3PPR	W	1	1	1	1	1	1	1	1	1	byte
00DAH	Timer 3 Register	T3	R	0	0	0	0	0	0	0	0	0	byte
	Timer 3 PWM Duty Register	T3PDR	R / W	0	0	0	0	0	0	0	0	0	byte, bit
	Timer 3 Capture Data Register	CDR3	R	0	0	0	0	0	0	0	0	0	byte
00DBH	Timer 3 PWM High Register	T3PWHR	W	-	-	-	-	0	0	0	0	0	byte
00E2H	8bit A/D Converter Mode Control Register	ADCM ³	R / W	0	0	0	0	0	0	0	0	1	byte, bit
00E3H	8bit A/D Converter Result Register Low	ADCRL	R	Undefined								byte	
00E4H	-	ADCRH	W, R	0	1	0	-	-	-	X	X		byte, bit
00E5H	Supply Voltage Level Detector Register	SVLDR	R / W	0	1	1	0	0	0	0	0	0	byte, bit
00E6H	Basic Interval Timer Register	BITR	R	Undefined								byte	
	Clock Control Register	CKCTLR	W	-	-	0	1	0	1	1	1	1	byte
00E7H	System Clock Mode Register	SCMR	R / W	-	-	-	-	-	0	0	0	0	byte
00E8H	Watch Dog Timer Register	WDTR	W	0	1	1	1	1	1	1	1	1	byte
	Watch Dog Timer Data Register	WDTDR	R	Undefined								byte	
	Watch Timer Register	WTR	W	0	1	1	1	1	1	1	1	1	byte
00E9H	Stop & Sleep Mode Control Register	SSCR	W	0	0	0	0	0	0	0	0	0	byte

Table 8-1 Control Registers

Address	Register Name	Symbol	R/W	Initial Value								Addressing Mode	
				7	6	5	4	3	2	1	0		
00EAH	Watch Timer Mode Register	WTMR	R / W	0	0	-	-	0	0	0	0	0	byte, bit
00F4H	-	INTFH	R / W	-	-	-	-	0	0	-	-	-	byte, bit
00F5H	Interrupt Generation Flag Register Low	INTFL	R / W	-	-	-	-	-	-	0	0	-	byte, bit
00F6H	-	IENH	R / W	-	0	0	0	0	0	0	-	-	byte, bit
00F7H	Interrupt Enable Register Middle	IENM	R / W	0	0	0	0	-	-	-	-	-	byte, bit
00F8H	Interrupt Enable Register Low	IENL	R / W	-	0	0	0	0	0	-	-	-	byte, bit
00F9H	-	IRQH	R / W	-	0	0	0	0	0	0	-	-	byte, bit
00FAH	Interrupt Request Register Middle	IRQM	R / W	0	0	0	0	-	-	-	-	-	byte, bit
00FBH	Interrupt Request Register Low	IRQL	R / W	-	0	0	0	0	0	-	-	-	byte, bit
00FCH	Interrupt Edge Selection Register	IEDS	R / W	0	0	0	0	0	0	0	0	0	byte, bit
00FFH	Watch timer Counter high read Register	WTRH	R	-	0	0	0	0	0	0	0	0	byte, bit

Table 8-1 Control Registers

1. "byte", "bit" means that register can be addressed by not only bit but byte manipulation instruction.
2. "byte" means that register can be addressed by only byte manipulation instruction. On the other hand, do not use any read-modify-write instruction such as bit manipulation.
3. bit 0 of ADCM is read only.

8.4 Addressing Mode

The MC80F7708A use six addressing modes;

- Register addressing
- Immediate addressing
- Direct page addressing
- Absolute addressing
- Indexed addressing
- Register-indirect addressing

(1) Register Addressing

Register addressing accesses the A, X, Y, C and PSW.

(2) Immediate Addressing → #imm

In this mode, second byte (operand) is accessed as a data immediately.

Example:

```
0435   ADC   #35H
```

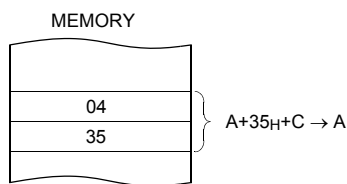

When G-flag is 1, then RAM address is defined by 16-bit address which is composed of 8-bit RAM paging register (RPR) and 8-bit immediate data.

Example: G=1, RPR=01H

```
E45535  LDM   35H, #55H
```

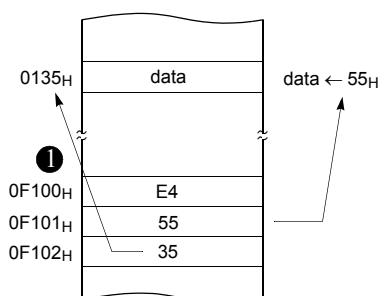

(3) Direct Page Addressing → dp

In this mode, a address is specified within direct page.

Example; G=0

```
C535   LDA   35H           ;A ←RAM[35H]
```

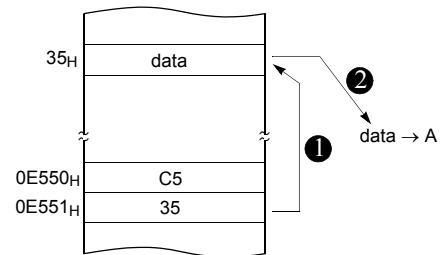

(4) Absolute Addressing → !abs

Absolute addressing sets corresponding memory data to Data, i.e. second byte (Operand I) of command becomes lower level address and third byte (Operand II) becomes upper level address.

With 3 bytes command, it is possible to access to whole memory area.

ADC, AND, CMP, CMPX, CMPY, EOR, LDA, LDX, LDY, OR, SBC, STA, STX, STY

Example;

```
0735F0  ADC   !0F035H      ;A ←ROM[0F035H]
```

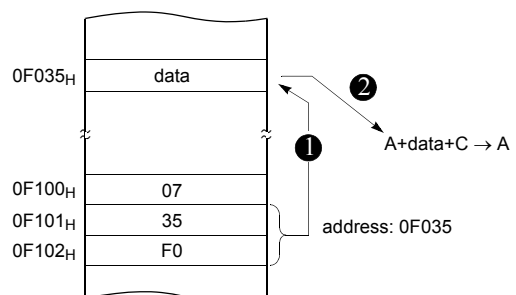

The operation within data memory (RAM)
ASL, BIT, DEC, INC, LSR, ROL, ROR

Example; Addressing accesses the address 0135H regardless of G-flag and RPR.

```
981501 INC !0115H ; A ←ROM[115H]
```

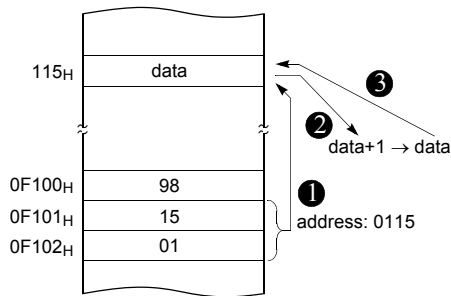

X indexed direct page, auto increment → {X}+

In this mode, a address is specified within direct page by the X register and the content of X is increased by 1.

LDA, STA

Example; G=0, X=35H

```
DB LDA {X}+
```

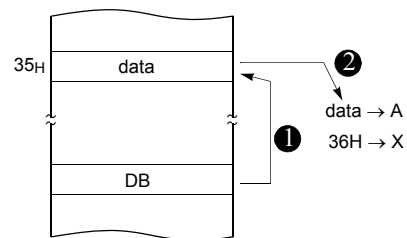

(5) Indexed Addressing

X indexed direct page (no offset) → {X}

In this mode, a address is specified by the X register.

ADC, AND, CMP, EOR, LDA, OR, SBC, STA, XMA

Example; X=15H, G=1, RPR=01H

```
D4 LDA {X} ; ACC←RAM[X].
```

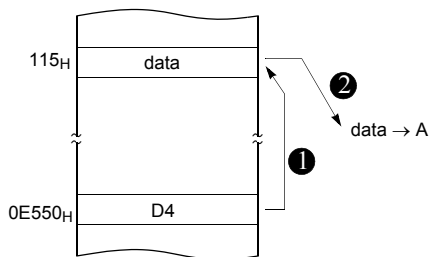

X indexed direct page (8 bit offset) → dp+X

This address value is the second byte (Operand) of command plus the data of X-register. And it assigns the memory in Direct page.

ADC, AND, CMP, EOR, LDA, LDY, OR, SBC, STA STY, XMA, ASL, DEC, INC, LSR, ROL, ROR

Example; G=0, X=0F5H

```
C645 LDA 45H+X
```

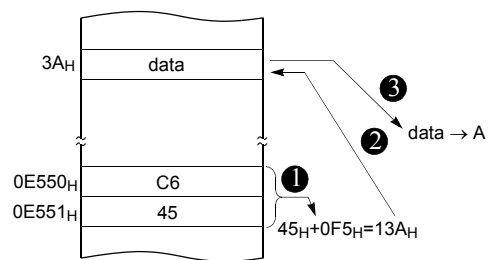

Y indexed direct page (8 bit offset) → dp+Y

This address value is the second byte (Operand) of command plus the data of Y-register, which assigns Memory in Direct page.

This is same with above. Use Y register instead of X.

Y indexed absolute → !abs+Y

Sets the value of 16-bit absolute address plus Y-register data as Memory. This addressing mode can specify memory in whole area.

Example; Y=55H

```
D500FA LDA !0FA00H+Y
```

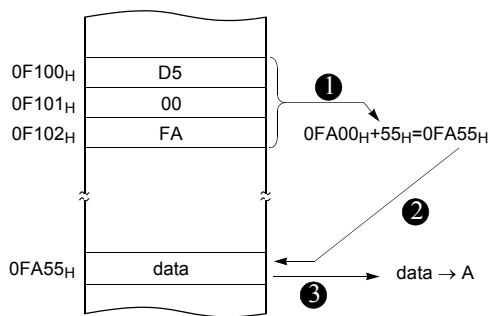

```
3F35 JMP [35H]
```

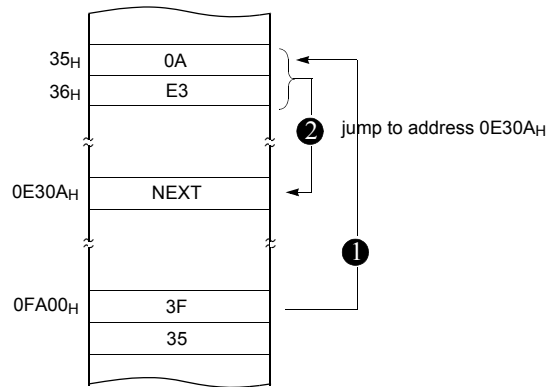

X indexed indirect → [dp+X]

Processes memory data as Data, assigned by 16-bit pair memory which is determined by pair data [dp+X+1][dp+X] Operand plus X-register data in Direct page.

ADC, AND, CMP, EOR, LDA, OR, SBC, STA

Example; G=0, X=10H

```
1 625 ADC [25H+X]
```

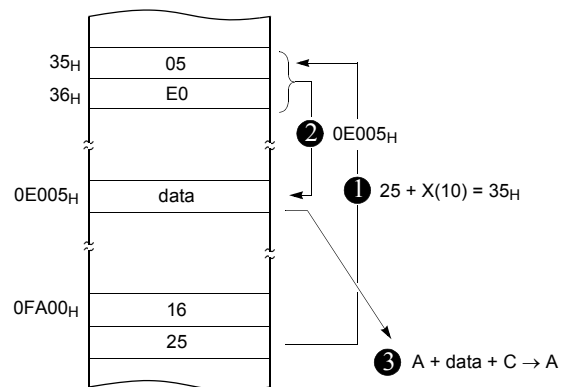

(6) Indirect Addressing

Direct page indirect → [dp]

Assigns data address to use for accomplishing command which sets memory data (or pair memory) by Operand. Also index can be used with Index register X, Y.

JMP, CALL

Example; G=0

Y indexed indirect → [dp]+Y

Processes memory data as Data, assigned by the data [dp+1][dp] of 16-bit pair memory paired by Operand in Direct page plus Y-register data.

ADC, AND, CMP, EOR, LDA, OR, SBC, STA

Example; G=0, Y=10_H

1725 ADC [25_H]+Y

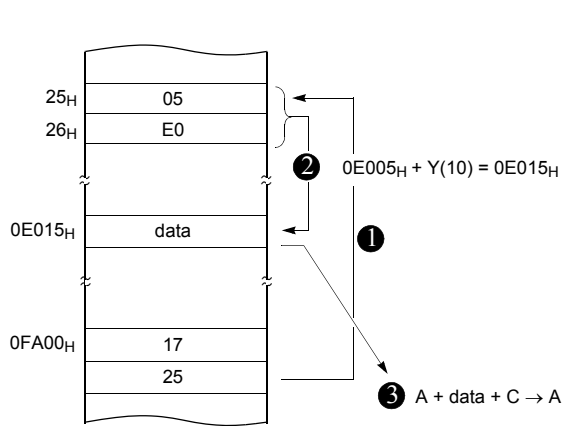

Absolute indirect → [!abs]

The program jumps to address specified by 16-bit absolute address.

JMP

Example; G=0

1F25E0 JMP [!0E025_H]

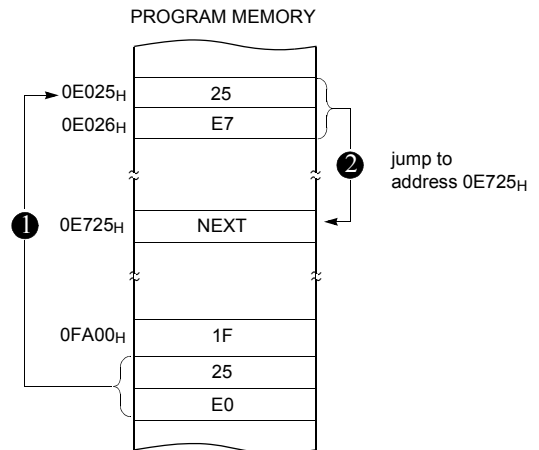

9. I/O PORTS

The MC80F7708A have seven I/O ports, LCD segment ports (R0, R1, R2, R4, R50/SEG0 ~ R73/SEG19) and LCD common ports (R77/COM0 ~ R74/COM3).

9.1 Registers for Ports

Port Data Registers

The Port Data Registers are represented as a D-Type flip-flop, which will clock in a value from the internal bus in response to a “write to data register” signal from the CPU. The Q output of the flip-flop is placed on the internal bus in response to a “read data register” signal from the CPU. The level of the port pin itself is placed on the internal bus in response to “read data register” signal from the CPU. Some instructions that read a port activating the “read register” signal, and others activating the “read pin” signal.

Port Direction Registers

All pins have data direction registers which can define these ports as output or input. A “1” in the port direction register configure the corresponding port pin as output. Conversely, write “0” to the corresponding bit to specify it as input pin. For example, to use the even numbered bit of R0 as output ports and the odd numbered bits as input ports, write “55H” to address 0C1H (R0 port direction register) during initial setting as shown in Figure 9-1.

All the port direction registers in the MC80F7708A have 0 written to them by reset function. Therefore, its initial status is input.

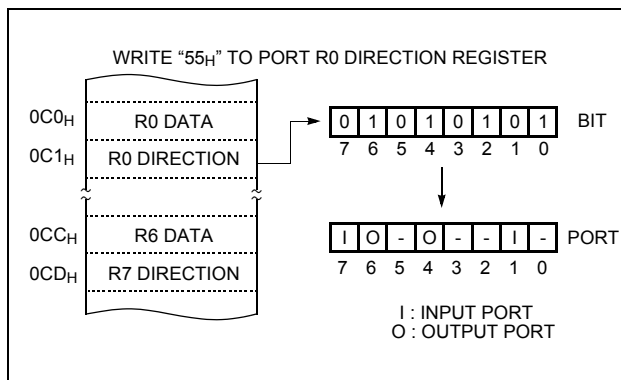

Figure 9-1 Example of port I/O assignment

Pull-up Control Registers

The R0, R1, R2 and R4 ports have internal pull-up resistors. Figure 9-2 shows a functional diagram of a typical

pull-up port. These ports pins may be multiplexed with an alternate function for the peripheral features on the device.

pull-up port. It is connected or disconnected by Pull-up Control register (R_nPU). The value of that resistor is typically 100kΩ. Refer to DC characteristics for more details.

When a port is used as key input, input logic is firmly either low or high, therefore external pull-down or pull-up resistors are required practically. The MC80F7708A have internal pull-up, it can be logic high by pull-up that can be able to configure either connect or disconnect individually by pull-up control registers R_nPU .

When ports are configured as inputs and pull-up resistor is selected by software, they are pulled to high.

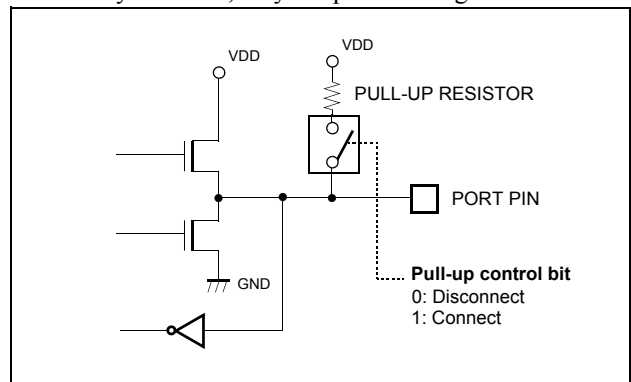

Figure 9-2 Pull-up Port Structure

Open drain port Registers

The R0, R1, R2 and R4 ports have open drain port resistors R0OD~R4OD.

Figure 9-3 shows an open drain port configuration by control register. It is selected as either push-pull port or open drain port by R0OD, R1OD, R2OD and R4OD.

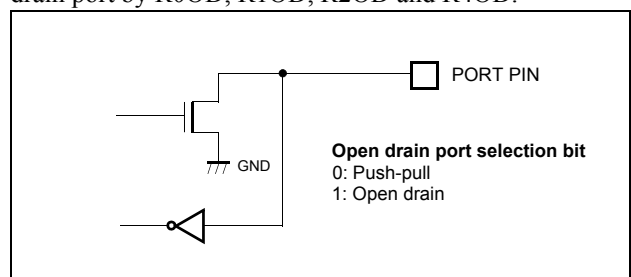

Figure 9-3 Open-drain Port Structure

9.2 I/O Ports Configuration

R0 Port

R0 is a 4-bit CMOS bidirectional I/O port (address 0C0_H). Each I/O pin can independently used as an input or an output through the R0IO register (address 0C1_H).

R0 has internal pull-ups that is independently connected or disconnected by R0PU. The control registers for R0 are shown below.

In addition, Port R0 is multiplexed with various special features. The control register PSR0 (address 0AA_H) controls the selection of alternate function. After reset, this value is “0”, port may be used as normal I/O port. To use alternate function such as External Interrupt rather than normal I/O, write “1” in the corresponding bit of PSR0.

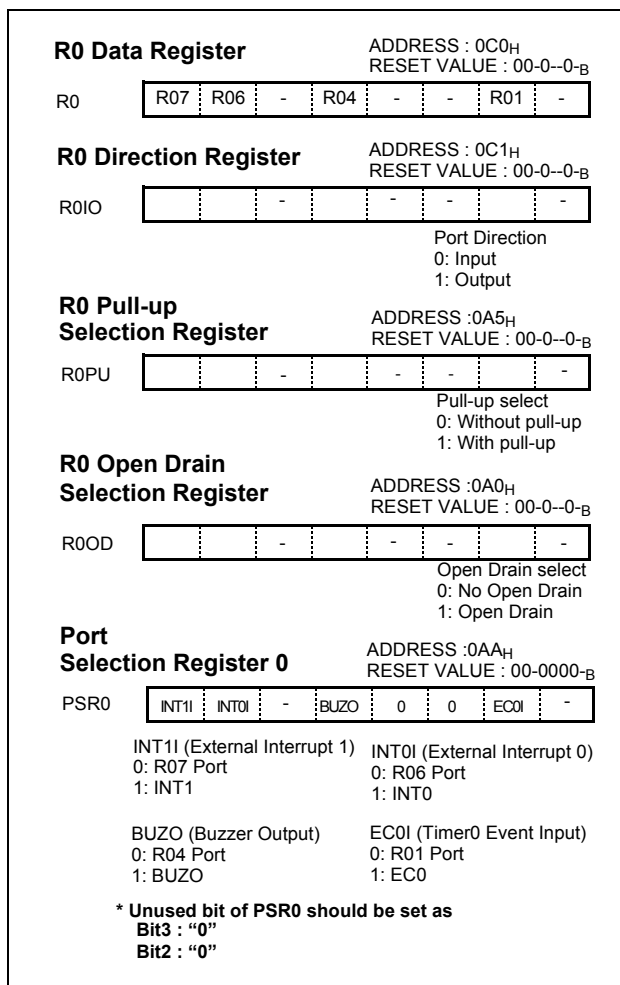

Port Pin	Alternate Function
R01	EC0 (Timer0 Event Input)
R04	BUZO (Buzzer Output)
R06	INT0 (External Interrupt 0)
R07	INT1 (External Interrupt 1)

Note: R0IO, R0PU, P0OD and PSR0 are write-only registers. They can not be read and can not be accessed by bit manipulation instruction. Do not use read or read-modify-write instruction. Use byte manipulation instruction.

R1 Ports

R1 is an 1-bit CMOS bidirectional I/O port (address 0C2_H). Each I/O pin can independently used as an input or an output through the R1IO register (address 0C3_H).

R1 has internal pull-up that is independently connected or disconnected by register R1PU. The control registers for R1 are shown below.

Port R1 is multiplexed with two special features. The control register controls the selection of alternate function. After reset, this value is “0”, port may be used as normal I/O port. The way to select alternate function such as PWM1 or Timer Output Wave will be shown in each peripheral section.

Note: R1IO, R1PU, P1OD and PSR1 are write-only registers. They can not be read and can not be accessed by bit manipulation instruction. Do not use read or read-modify-write instruction. Use byte manipulation instruction.

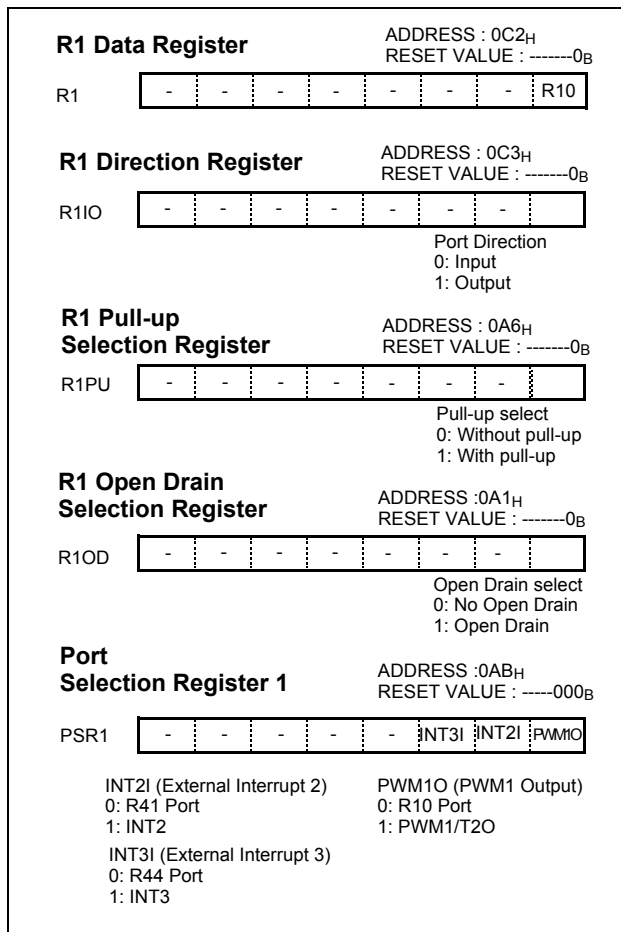

R2 Ports

R2 is a 6-bit CMOS bidirectional I/O port (address 0C4_H). Each I/O pin can independently used as an input or an output through the R2IO register (address 0C5_H).

R2 has internal pull-ups that are independently connected or disconnected by R2PU (address 0A7_H). The control registers for R2 are shown as below.

Note: R2IO, R2PU and P2OD are write-only registers. They can not be read and can not be accessed by bit ma-

nipulation instruction. Do not use read or read-modify-write instruction. Use byte manipulation instruction.

Note: The R24 and R25 are not supported in the MC80F7708AK.

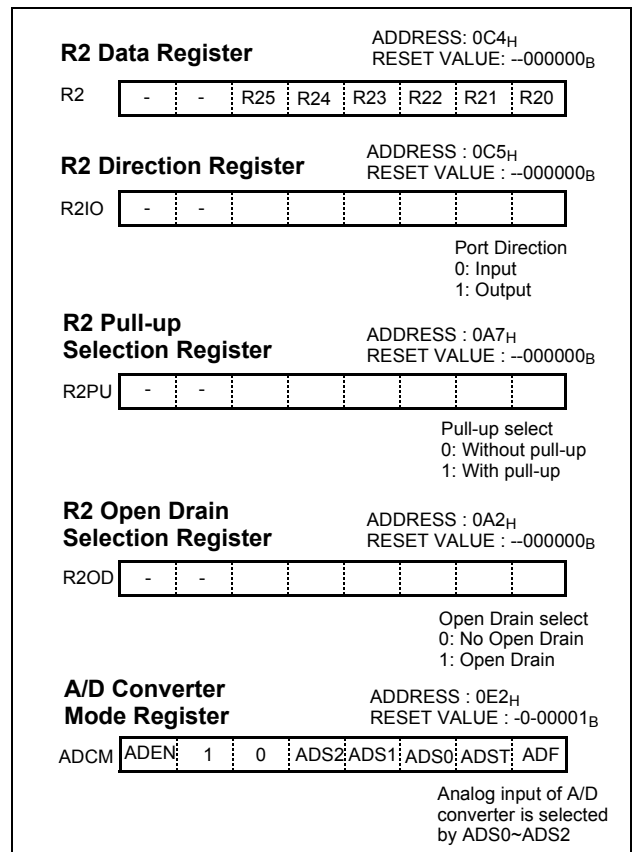

R4 Port

R4 is a 7-bit CMOS bidirectional I/O port (address 0C8_H). Each I/O pin can independently used as an input or an output through the R4IO register (address 0C9_H).

R4 has internal pull-ups that is independently connected or disconnected by R4PU. The control registers for R4 are shown below.

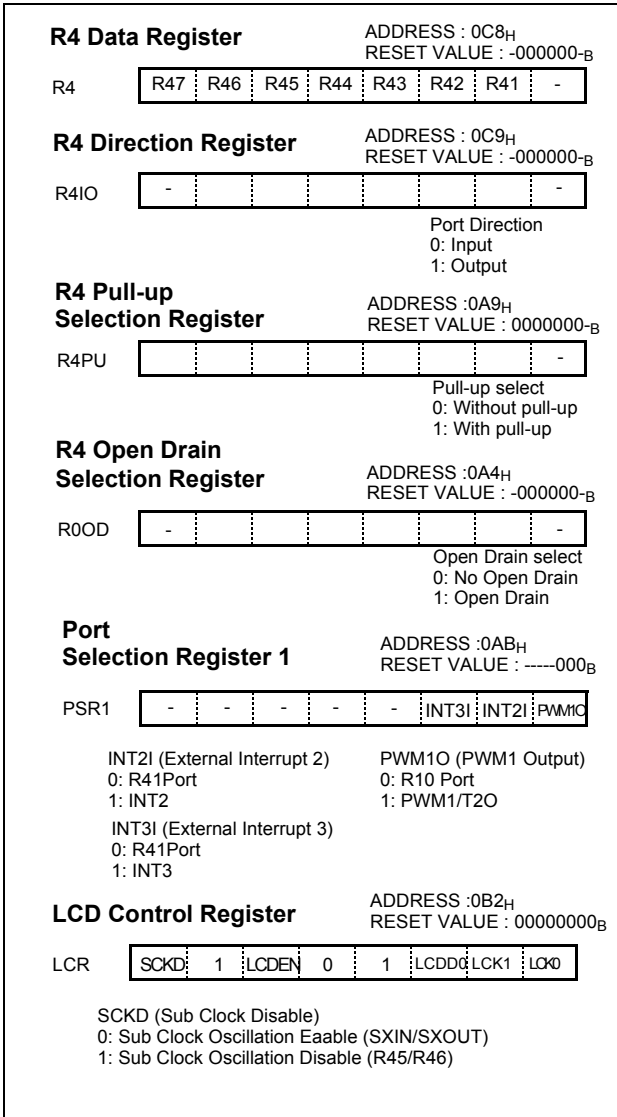

In addition, Port R4 is multiplexed with oscillation input/output, reset and interrupt input pins. The control register PSR1 (address 0AB_H) controls the selection of alternate function. After reset, this value is “0”, port may be used as normal I/O port. To use alternate function such as External Interrupt rather than normal I/O, write “1” in the corresponding bit of PSR1.

Main oscillation input/output and reset pin can be used as normal I/O ports (R43/R42) and normal input port(R47) by selecting configuration options in flash writing. Sub oscillation input/output pin can be used as normal I/O ports by writing “1” to the SCKD bit of the LCR register

Port Pin	Alternate Function
R41	INT2 (External Interrupt 2)
R42	X _{OUT} (Oscillation Output)
R43	X _{IN} (Oscillation Input)
R44	INT3 (External Interrupt 3)
R45	SX _{IN} (Subsystem Oscillation Input)
R46	SX _{OUT} (Subsystem Oscillation Output)
R47	RESET (System Reset Input)

Note: R4IO, R4PU, P4OD and PSR1 are write-only registers. They can not be read and can not be accessed by bit manipulation instruction. Do not use read or read-modify-write instruction. Use byte manipulation instruction.

R5 Ports

R5 is an 8-bit CMOS bidirectional I/O port (address 0CA_H). Each I/O pin can independently used as an input or an output through the R5IO register (address 0CB_H).

R5 is multiplexed with LCD segment output(SEG0 ~ SEG7), which can be selected by writing appropriate value into the R5PSR(address 0AC_H).

R50, R1, R52 is also multiplexed with RX0, TX0 and ACK, which can be selected by writing appropriate value into the ASIMR0(address 0B8_H).

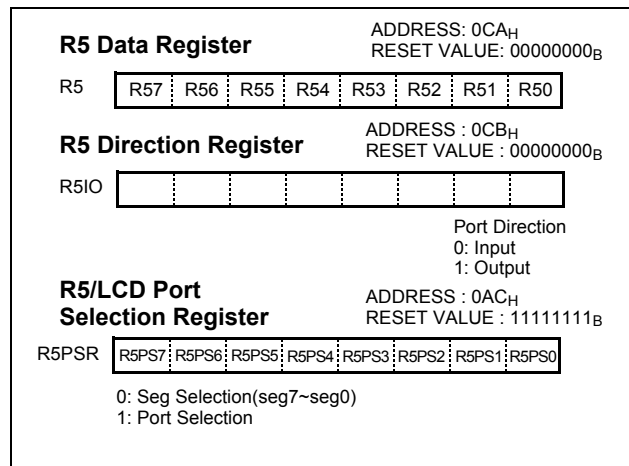

Note: R5IO is write-only register. It can not be read and can not be accessed by bit manipulation instruction. Do not use read or read-modify-write instruction. Use byte manipulation instruction.

R6 Ports

R6 is an 8-bit CMOS bidirectional I/O port (address 0CC_H). Each I/O pin can independently used as an input or an output through the R6IO register (address 0CD_H).

R6 is multiplexed with LCD segment output(SEG8 ~ SEG15), which can be selected by writing appropriate value into the R6PSR(address 0AD_H).

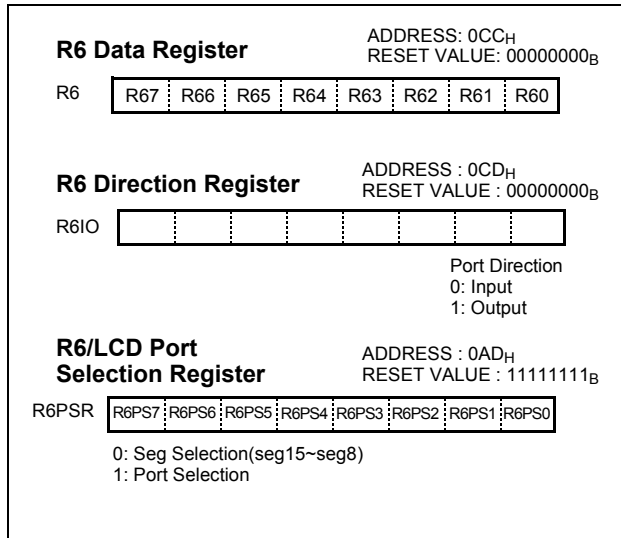

Note: R6IO is write-only register. It can not be read and can not be accessed by bit manipulation instruction. Do not use read or read-modify-write instruction. Use byte manipulation instruction.

R7 Ports

R7 is a 8-bit CMOS bidirectional I/O port (address 0B0_H). Each I/O pin can independently used as an input or an output through the R7IO register (address 0B4_H).

R7 is multiplexed with LCD common output (COM4 ~ COM0) and segment output(SEG16 ~ SEG19), which can be selected by writing appropriate value into the R7PSR(address 0AE_H) and LCR(address 0B2_H).

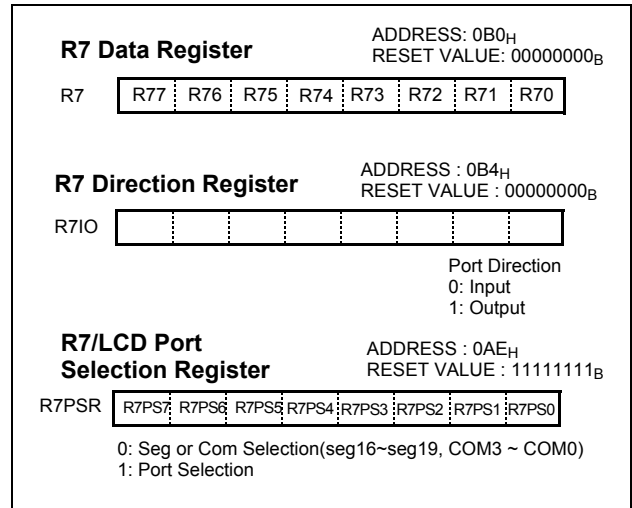

Note: R7IO is write-only register. It can not be read and can not be accessed by bit manipulation instruction. Do not use read or read-modify-write instruction. Use byte manipulation instruction.

SEG0~SEG19

Segment signal output pins for the LCD display. See "18. LCD DRIVER" on page 78 for details.

COM0~COM3

Common signal output pins for the LCD display. See "18. LCD DRIVER" on page 78 for details.

SEG16~SEG19 and COM3~COM0 are selected by LCDD of the LCR register.

10. CLOCK GENERATOR

As shown in Figure 10-1, the clock generator produces the basic clock pulses which provide the system clock to be supplied to the CPU and the peripheral hardware. It contains two oscillators which are main-frequency clock oscillator and a sub-frequency clock oscillator. The system clock can also be obtained from the external oscillator. By setting configuration option, the internal 8MHz, 4MHz, 2MHz can also be selected for system clock source.

The clock generator produces the system clocks forming clock pulse, which are supplied to the CPU and the peripheral hardware.

The internal system clock should be selected to main oscillation by setting bit1 and bit0 of the system clock mode register (SCMR). The registers are shown in Figure 10-2.

To the peripheral block, the clock among the not-divided original clocks, divided by 2, 4,..., up to 4096 can be provided. Peripheral clock is enabled or disabled by STOP instruction. The peripheral clock is controlled by clock control register (CKCTLR). See "11. BASIC INTERVAL TIMER" on page 43 for details.

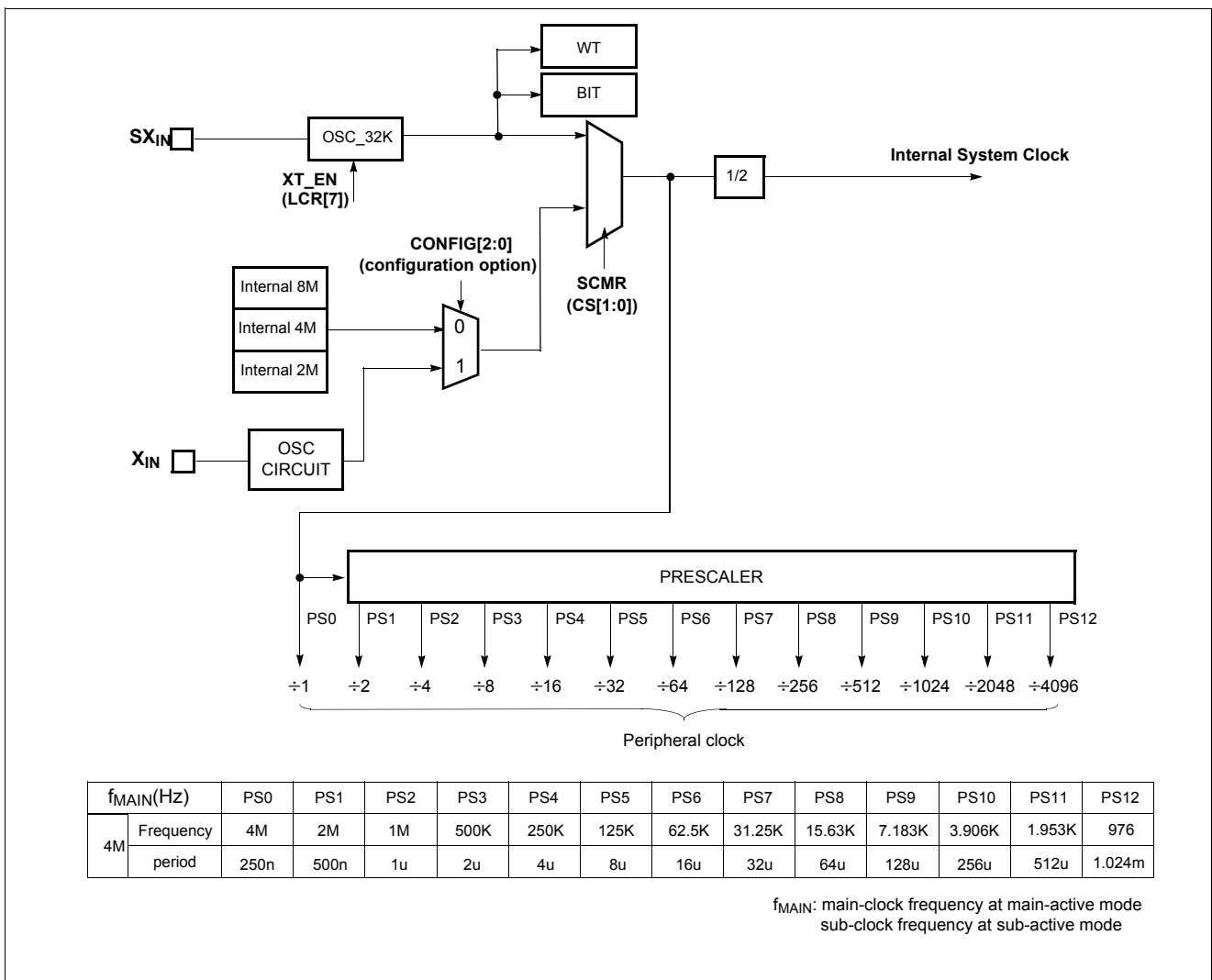

Figure 10-1 Block Diagram of Clock Generator

The SCMR should be set to operate by main oscillation. Bit2, bit1 and bit0 of the SCMR should be set to "000" or "001" to select main oscillation.

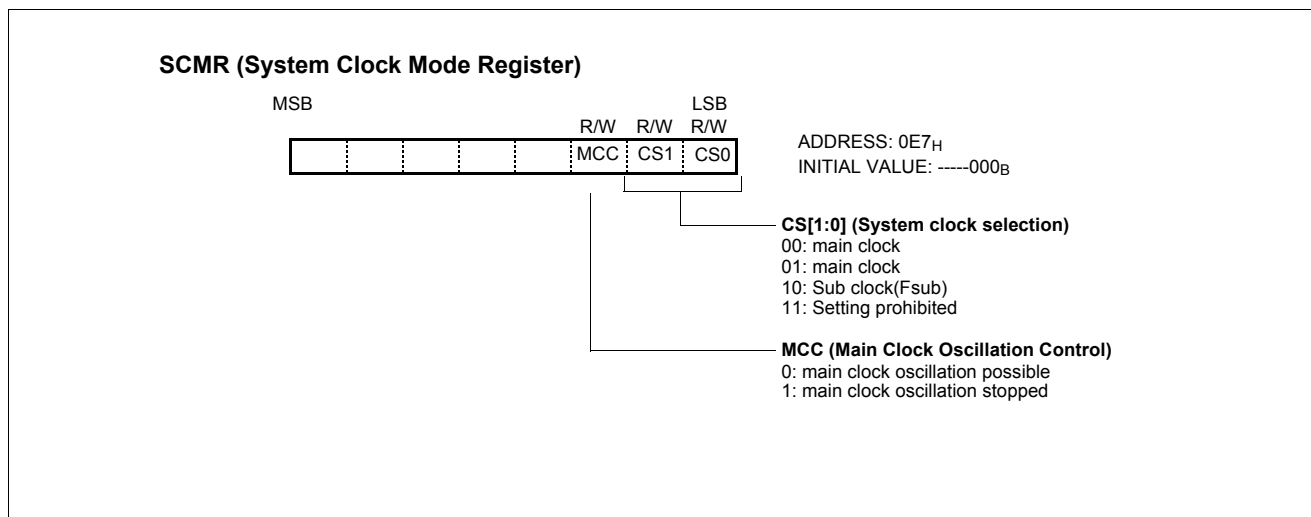

Figure 10-2 SCMR : System Clock Mode Register

11. BASIC INTERVAL TIMER

The MC80F7708A have one 8-bit Basic Interval Timer that is free-run and can not stop. Block diagram is shown in Figure 11-1.

The Basic Interval Timer Register (BITR) is increased every internal count pulse which is divided by prescaler. Since prescaler has division ratio from 8 to 1024, the count rate is 1/8 to 1/1024 of the oscillator frequency. After reset, the BCK bits are all set, so the longest oscillation stabilization time is obtained.

It also provides a Basic interval timer interrupt (BITF). The count overflow of BITR from FF_H to 00_H causes the

interrupt to be generated. The Basic Interval Timer is controlled by the clock control register (CKCTLR) shown in Figure 11-2.

Source clock can be selected by lower 3 bits of CKCTLR. When write “1” to bit BCL of CKCTLR, BITR register is cleared to “0” and restart to count up. The bit BCL becomes “0” automatically after one machine cycle by hardware.

BITR and CKCTLR are located at same address, and address 0E6_H is read as a BITR, and written to CKCTLR.

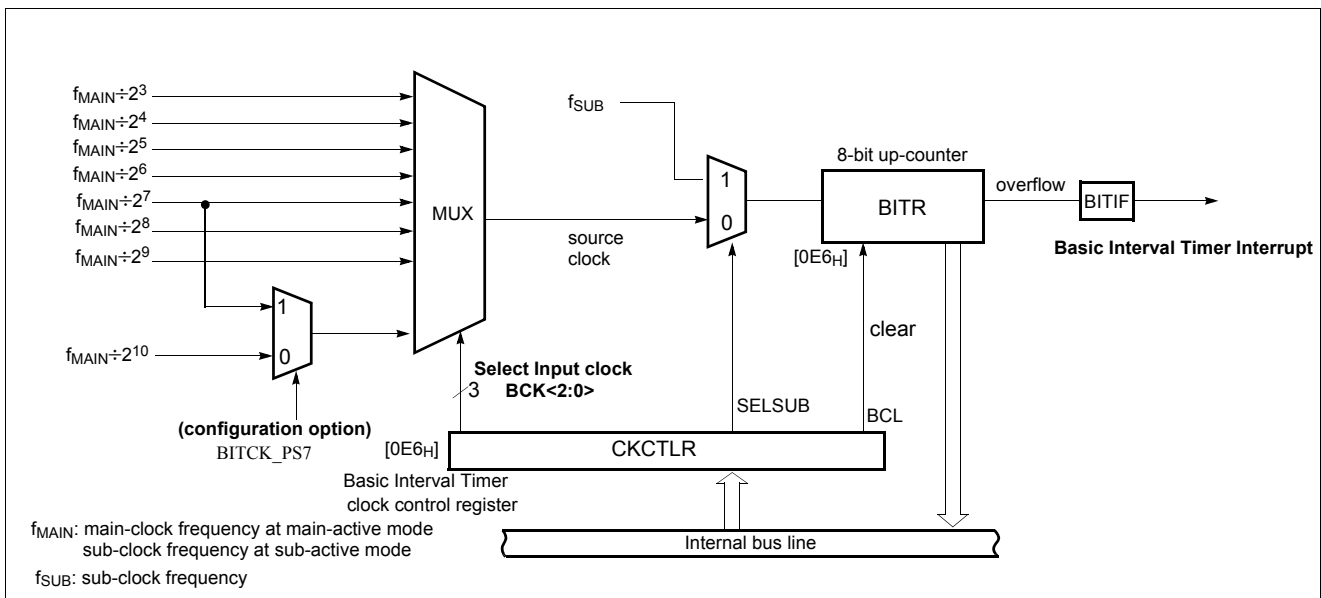

Figure 11-1 Block Diagram of Basic Interval Timer

BCK<2:0>	Source clock	Interrupt (overflow) Period
	SCMR[1:0] = 00 or 01	At f _{MAIN} = 4MHz
000	f _{MAIN} ÷ 2 ³	0.512 ms
001	f _{MAIN} ÷ 2 ⁴	1.024
010	f _{MAIN} ÷ 2 ⁵	2.048
011	f _{MAIN} ÷ 2 ⁶	4.096
100	f _{MAIN} ÷ 2 ⁷	8.192
101	f _{MAIN} ÷ 2 ⁸	16.384
110	f _{MAIN} ÷ 2 ⁹	32.768
111	f _{MAIN} ÷ 2 ¹⁰	65.536

Table 11-1 Basic Interval Timer Interrupt Time

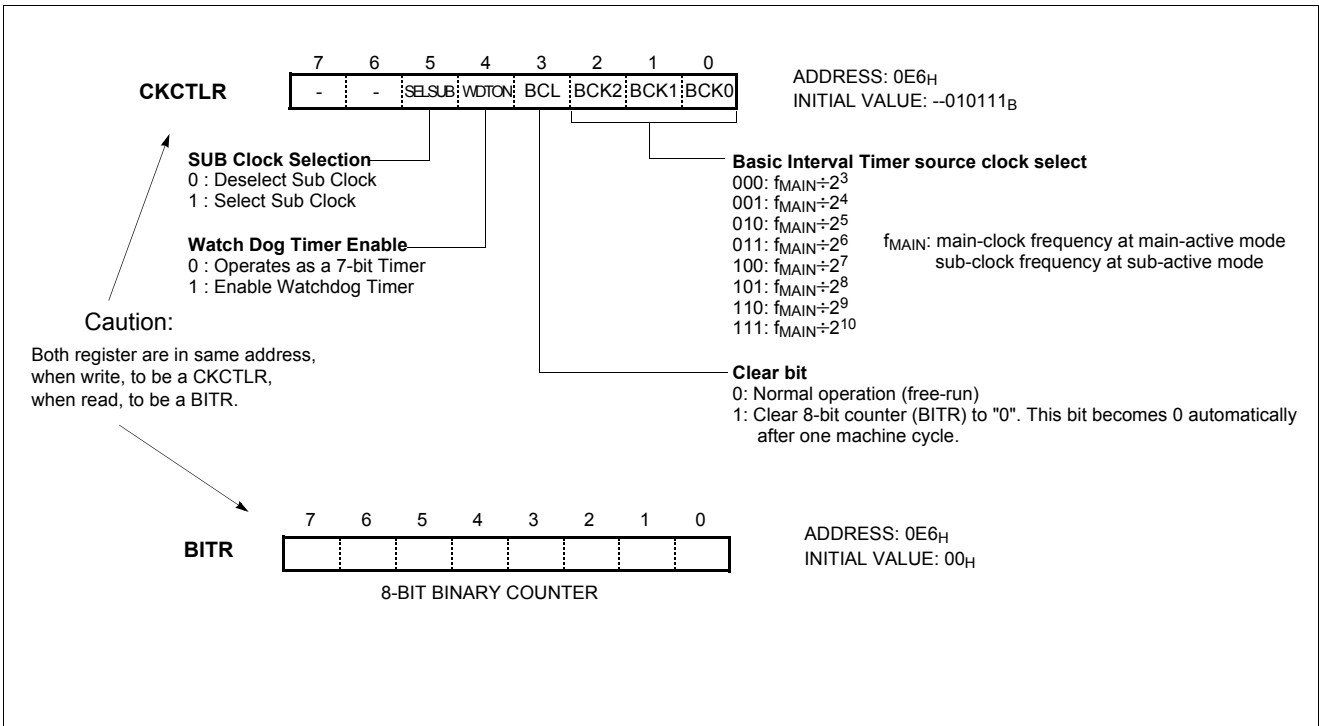

Figure 11-2 BITR: Basic Interval Timer Mode Register

Example 1:

Interrupt request flag is generated every 8.192ms at 4MHz.

```

:
LDM  CKCTRL, #0CH
SET1  BITE
EI
:
    
```

12. TIMER / COUNTER

Timer/Event Counter consists of prescaler, multiplexer, 8-bit timer data register, 8-bit counter register, mode register, input capture register and Comparator as shown in Figure 12-4. And the PWM high register for PWM is consisted separately.

The timer/counter has seven operating modes.

- 8 Bit Timer/Counter Mode
- 8 Bit Capture Mode
- 8 Bit Compare Output Mode
- 16 Bit Timer/Counter Mode
- 16 Bit Capture Mode
- 16 Bit Compare Output Mode
- PWM Mode

In the “timer” function, the register is increased every internal clock input. Thus, one can think of it as counting internal clock input. Since a least clock consists of 2 and

Example 1:

Timer 0 = 8-bit timer mode, 8ms interval at 4MHz

Timer 1 = 8-bit timer mode, 4ms interval at 4MHz

```
LDM SCMR,#0 ;Main clock mode
LDM TDR0,#249
LDM TM0,#0001_0011B
LDM TDR1,#124
LDM TM1,#0000_1111B

SET1 TOE
SET1 T1E
EI
:
:
:
```

Example 2:

Timer0 = 16-bit timer mode, 0.5s at 4MHz

```
LDM SCMR,#0 ;Main clock mode
LDM TDR0,#23H
LDM TDR1,#0F4H
LDM TM0,#0FH ;FMAIN/32, 8us
LDM TM1,#4CH

SET1 TOE
EI
:
:
:
```

most clock consists of 2048 oscillator periods, the count rate is 1/2 to 1/2048 of the oscillator frequency in Timer0. And Timer1 can use the same clock source too. In addition, Timer1 has more fast clock source (1/1 to 1/8).

In the “counter” function, the register is increased in response to a 0-to-1 (rising edge) transition at its corresponding external input pin EC0 (Timer 0).

In addition the “capture” function, the register is increased in response external or internal clock interrupt same with timer/counter function. When external interrupt edge input, the count register is captured into capture data register TMx.

Timer3 is shared with “PWM” function and Timer2 is shared with “Compare output” function.

Example 3:

Timer0 = 8-bit event counter

Timer2 = 8-bit capture mode, 2us sampling count.

```
LDM TDR0,#0FFH ;don't care
LDM TM0,#1FH ;event counter
LDM ROIO,#1XXX_XX1XB ;R07, R01 input

LDM IEDS,#XXXX_01XXB ;FALLING
LDM PSR0,#1XXX_XX1XB;INT1,EC0
LDM TDR2,#0FFH
LDM TM2,#0010_1011B ;2us

SET1 TOE ;ENABLE TIMER 0
SET1 T2E ;ENABLE TIMER 1
SET1 INT1E ;ENABLE INT1
EI
:
```

X: don't care.

Example 4:

Timer0 = 16-bit capture mode, 8us sampling count. at 4MHz

```
LDM TDR0,#0FFH
LDM TDR1,#0FFH
LDM TM0,#2FH
LDM TM1,#5FH

LDM IEDS,#XXXX_XX01B
LDM PSR0,#X1XX_XXXXB ;AS INT0

SET1 TOE ;ENABLE TIMER 0
SET1 INTOE ;ENABLE EXT. INT0
EI
:
```

X: don't care.

TM0, TM2 (Timer0, 2 Mode Control Register)

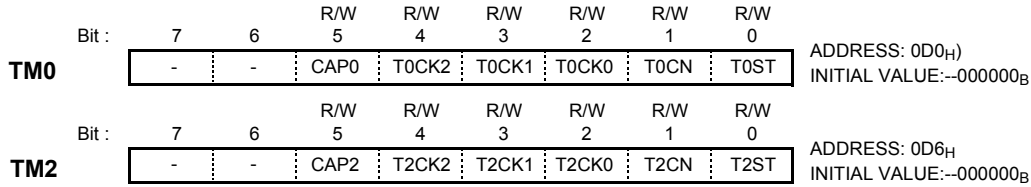

- CAP0,CAP2 (Capture Mode Selection Bit)**
0: Timer/Counter Mode
1: Capture Mode
- T0CN,T2CN (Timer 0,2 Continue Start)**
0: Pause Counting
1: Continue Counting
- T0ST,T2ST (Timer 0,2 Start Control)**
0: Stop Counting
1: Clear the counter and Start counting again
- T0CK[2:0],T2CK[2:0] (Timer 0,2 Input Clock Selection)**
- | | |
|-------------------------------|-----------------------------|
| T0CK[2:0] | T2CK[2:0] |
| 000: $f_{MAIN} \div 2$ | 000: $f_{MAIN} \div 2$ |
| 001: $f_{MAIN} \div 2^2$ | 001: $f_{MAIN} \div 2^2$ |
| 010: $f_{MAIN} \div 2^3$ | 010: $f_{MAIN} \div 2^4$ |
| 011: $f_{MAIN} \div 2^5$ | 011: $f_{MAIN} \div 2^6$ |
| 100: $f_{MAIN} \div 2^7$ | 100: $f_{MAIN} \div 2^8$ |
| 101: $f_{MAIN} \div 2^9$ | 101: $f_{MAIN} \div 2^{10}$ |
| 110: $f_{MAIN} \div 2^{11}$ | 110: $f_{MAIN} \div 2^{12}$ |
| 111: External Event clock ECO | 111: Reserved |
- f_{MAIN} : main-clock frequency at main-active mode
sub-clock frequency at sub-active mode

TM1, TM3 (Timer1, 3 Mode Control Register)

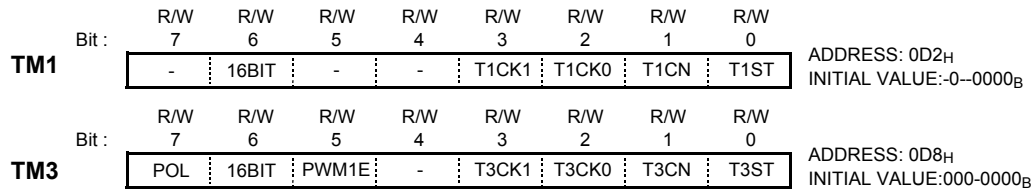

- POL (PWM Output Polarity Selection)**
0: Duty Active Low
1: Duty Active High
- 16BIT (16 Bit Mode Selection)**
0: 8-Bit Mode
1: 16-Bit Mode
- PWM1E (PWM Enable Bit)**
0: PWM1 Disable (T2O Enable)
1: PWM1 Enable (T2O Disable)
- T1CK[1:0],T3CK[1:0] (Timer 1,3 Input Clock Selection)**
- | | |
|-------------------------|-------------------------|
| T1CK[1:0] | T3CK[1:0] |
| 00: f_{MAIN} | 00: f_{MAIN} |
| 01: $f_{MAIN} \div 2$ | 01: $f_{MAIN} \div 2$ |
| 10: $f_{MAIN} \div 2^3$ | 10: $f_{MAIN} \div 2^4$ |
| 11: Timer0 Clock | 11: Timer2 Clock |
- f_{MAIN} : main-clock frequency at main-active mode
sub-clock frequency at sub-active mode
- T1CN,T3CN (Timer 1,3 Continue Start)**
0: Stop Counting
1: Start Counting
- T1ST,T3ST (Timer 1,3 Start Control)**
0: Stop counting
1: Clear the counter and start count again

****The counter will be cleared and restarted only when the TxST bit cleared and set again.
If TxST bit set again when TxST bit is set, the counter can't be cleared but only start again.**

T0CK2	T0CK1	T0CK0		4MHz	8MHz	10MHz
0	0	0	$(f_{MAIN} \div 2)$	500nS	250nS	200nS
0	0	1	$(f_{MAIN} \div 2^2)$	1uS	500nS	400nS
0	1	0	$(f_{MAIN} \div 2^3)$	2uS	1uS	800nS
0	1	1	$(f_{MAIN} \div 2^5)$	8uS	4uS	3.2uS
1	0	0	$(f_{MAIN} \div 2^7)$	32uS	16uS	12.8uS
1	0	1	$(f_{MAIN} \div 2^9)$	128uS	64uS	51.2uS
1	1	0	$(f_{MAIN} \div 2^{11})$	512uS	256uS	204.8uS

f_{MAIN} : main-clock frequency at main-active mode
sub-clock frequency at sub-active mode

Figure 12-1 Timer0,1,2,3 Registers

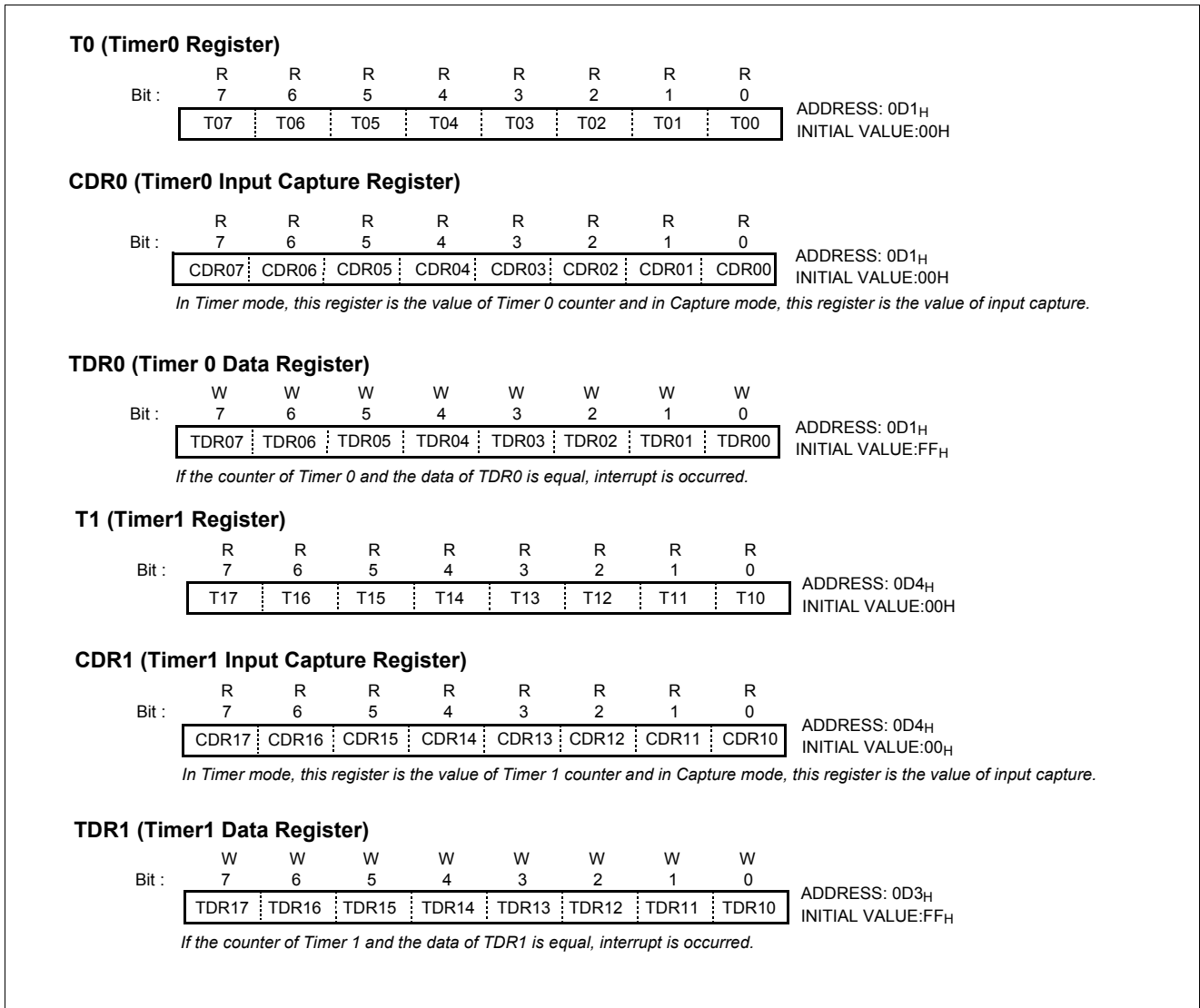

Figure 12-2 Related Registers with Timer/Counter0, 1

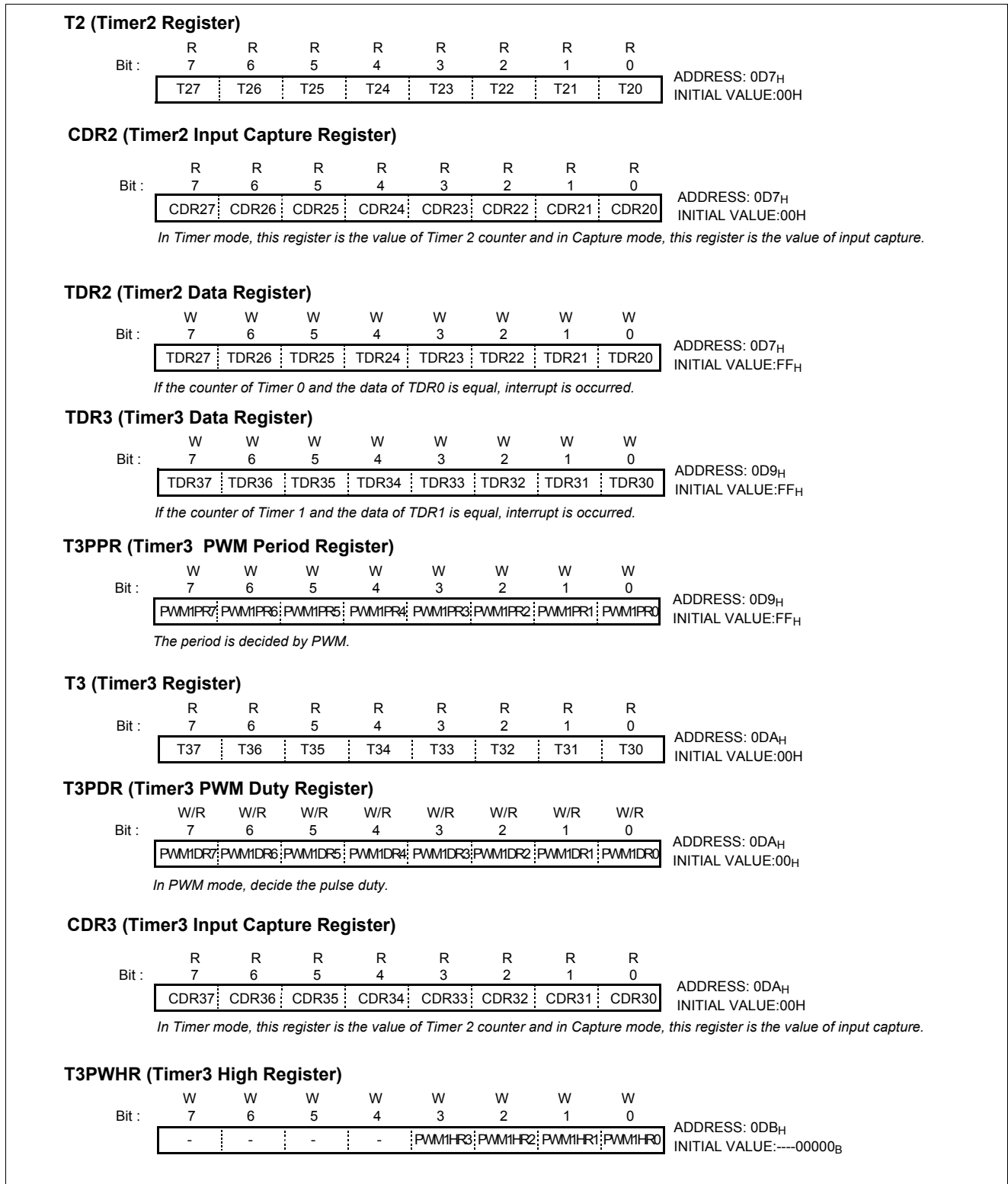

Figure 12-3 Related Registers with Timer/Counter2, 3

16BIT	CAP0	-	T0CK[2:0]	T1CK[1:0]	Timer 0	Timer 1
0	0	-	XXX	XX	8 Bit Timer	8 Bit Timer
0	0	-	111	XX	8 Bit Event Counter	8 Bit Timer
0	1	-	XXX	XX	8 Bit Capture	8 Bit Compare Output
1	0	-	XXX	11	16 Bit Timer	
1	0	-	111	11	16 Bit Event Counter	
1	1	-	XXX	11	16 Bit Capture	
1	0	-	XXX	11	16 Bit Compare Output	

Table 12-1 Operating Modes of Timer 0 and Timer 1

12.1 8-Bit Timer/Counter Mode

The MC80F7708A have four 8-bit Timer/Counters, Timer0, Timer1, Timer2 and Timer3 as shown in Figure 12-4.

The “timer” or “counter” function is selected by mode reg-

isters TMx (x=0,1,2,3) as shown in Figure 12-1 and Table 12-1. To use as an 8-bit timer/counter mode, bit CAPx of TMx is cleared to “0” and bits 16BIT of TM1(3) should be cleared to “0” (Table 12-1).

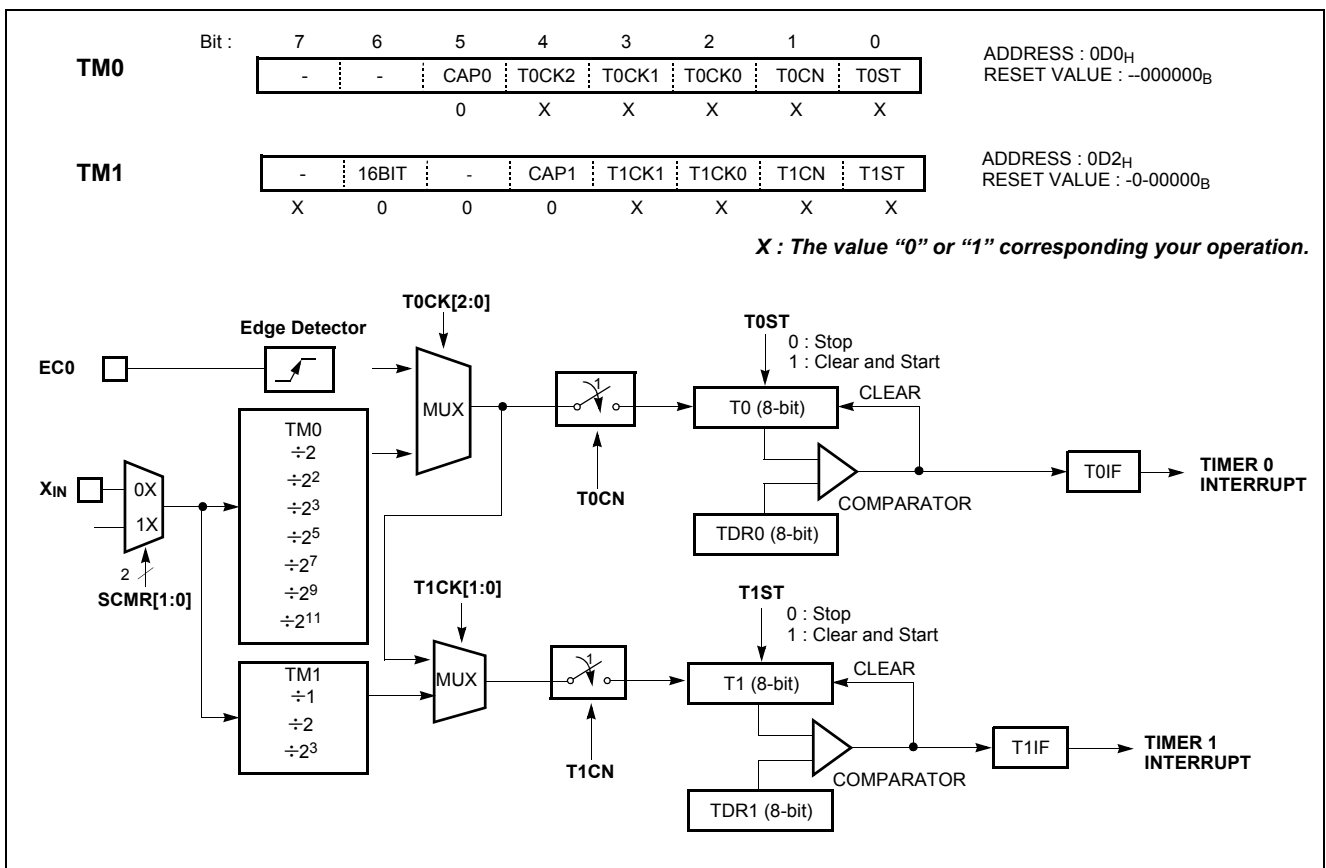

Figure 12-4 Block Diagram of Timer/Event Counter0,1

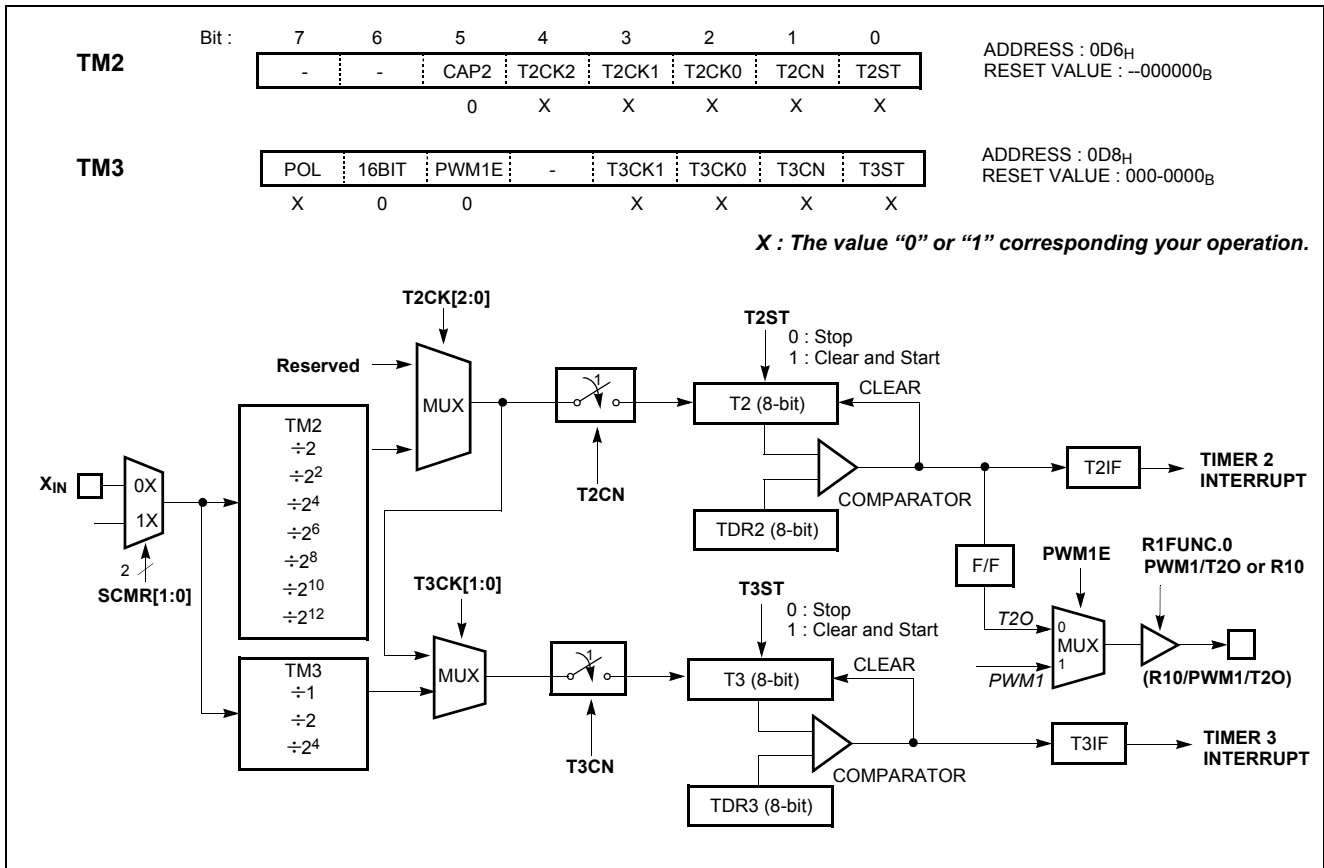

Figure 12-5 Block Diagram of Timer 2,3

These timers have each 8-bit count register and data register. The count register is increased by every internal or external clock input. The internal clock has a prescaler divide ratio option of 2, 4, 8, 32, 128, 512, 2048 (selected by control bits TxCK2, TxCK1 and TxCK0 of register TM0(2)) and 1, 2, 8 (selected by control bits TxCK1 and TxCK0 of register TM1(3)).

In the Timer, timer register Tx increases from 00_H until it matches TxDR and then reset to 00_H. If the value of Tx is equal with TxDR, Timer x interrupt is occurred (latched in TxIF bit). TxDR and T0 register are in same address, so this register is read from T0 and written to TDR0.

In counter function, the counter is increased every 0-to 1 (rising edge) transition of EC0 pin. In order to use counter function, the bit R01 of the R0 Direction Register (R0IO) should be set to "0" and the bit EC0E of Port Selection Register PSR0 should set to "1". The Timer 0 can be used as a counter by pin EC0 input, but other timers can not used as a event counter.

Note: The contents of TDR0, TDR1, TDR2 and TDR3 must be initialized (by software) with the value between 1_H and 0FF_H, not 0_H.

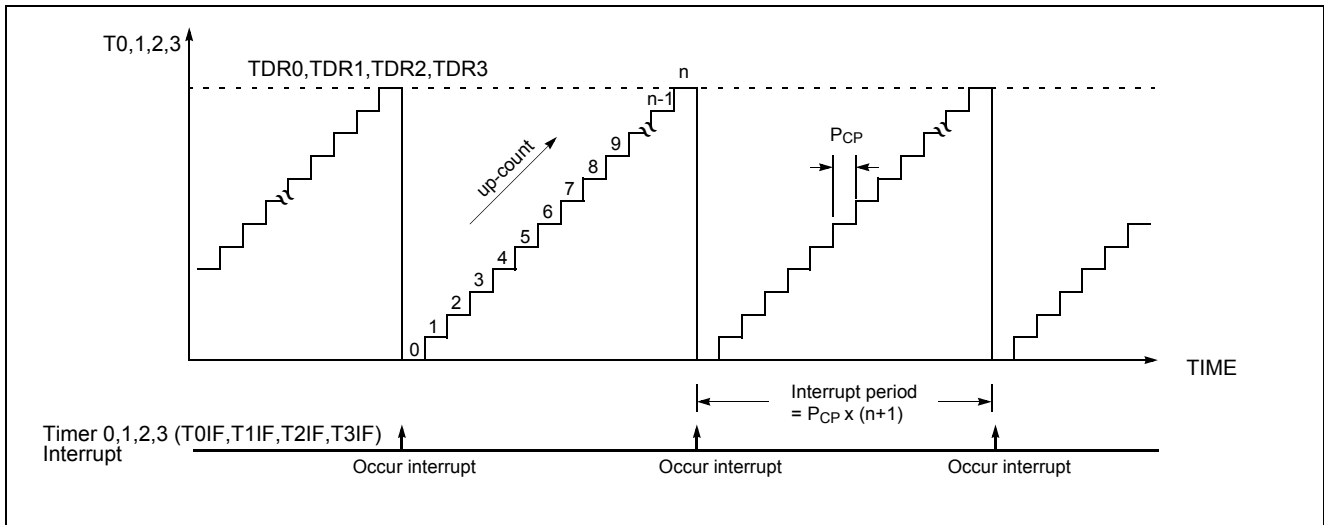

Figure 12-6 Counting Example of Timer Data Registers

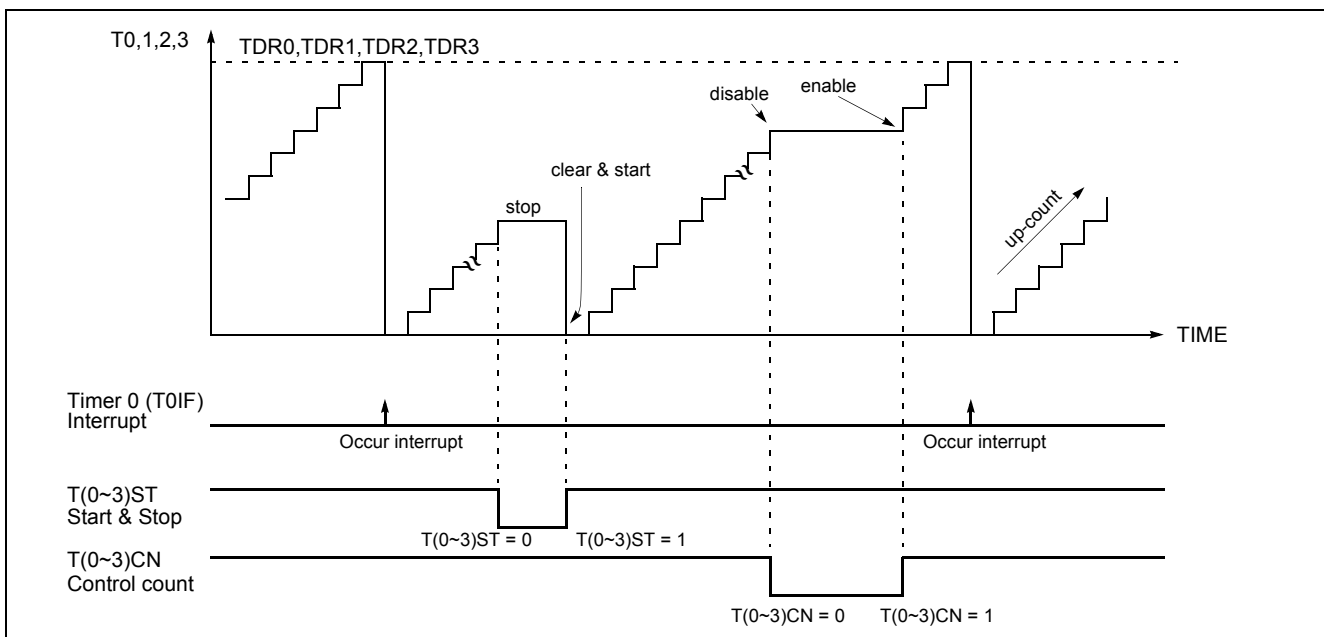

Figure 12-7 Timer Count Operation

12.2 16 Bit Timer/Counter Mode

The Timer register is running with 16 bits. A 16-bit timer/counter register T0, T1 are increased from 0000_H until it matches TDR0, TDR1 and then resets to 0000_H. The match output generates Timer 0 interrupt not Timer 1 interrupt.

The clock source of the Timer 0 is selected either internal or external clock by bit T0CK2, T0CK1 and T0CK0.

In 16-bit mode, the bits T1CK1, T1CK0 and 16BIT of TM1

should be set to “1” respectively.

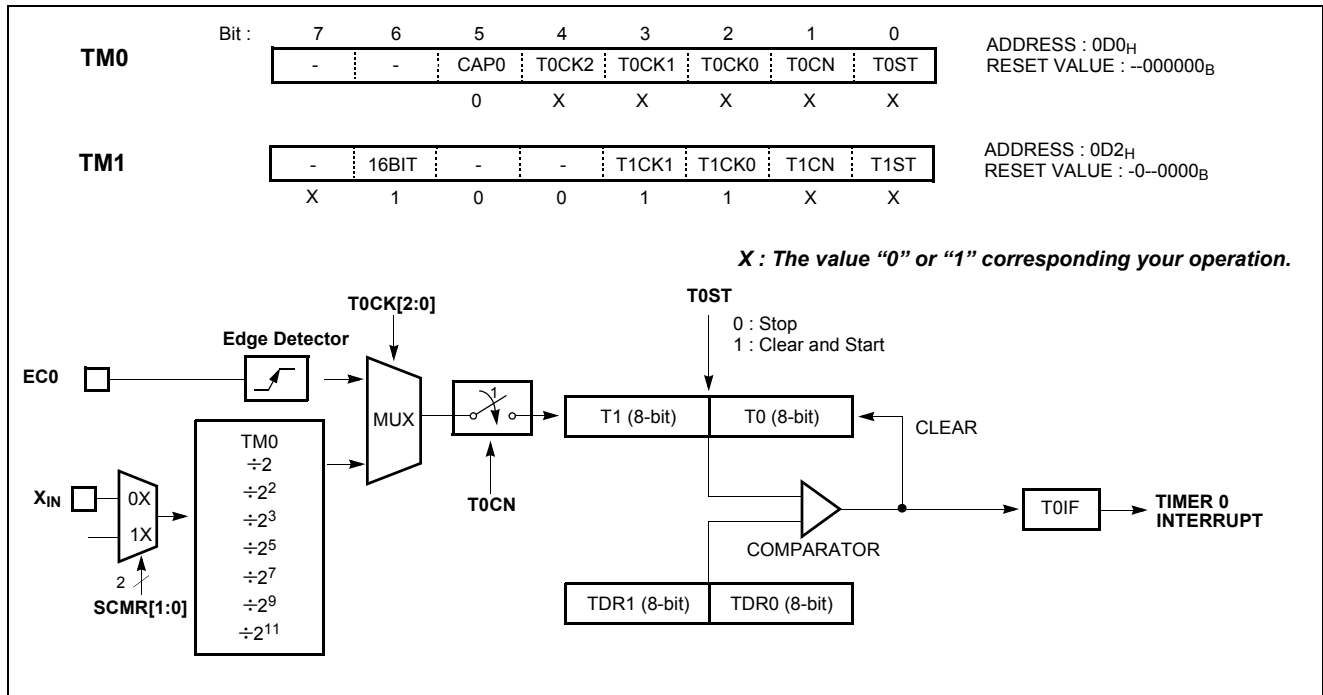

Figure 12-8 16-bit Timer / Counter Mode 0

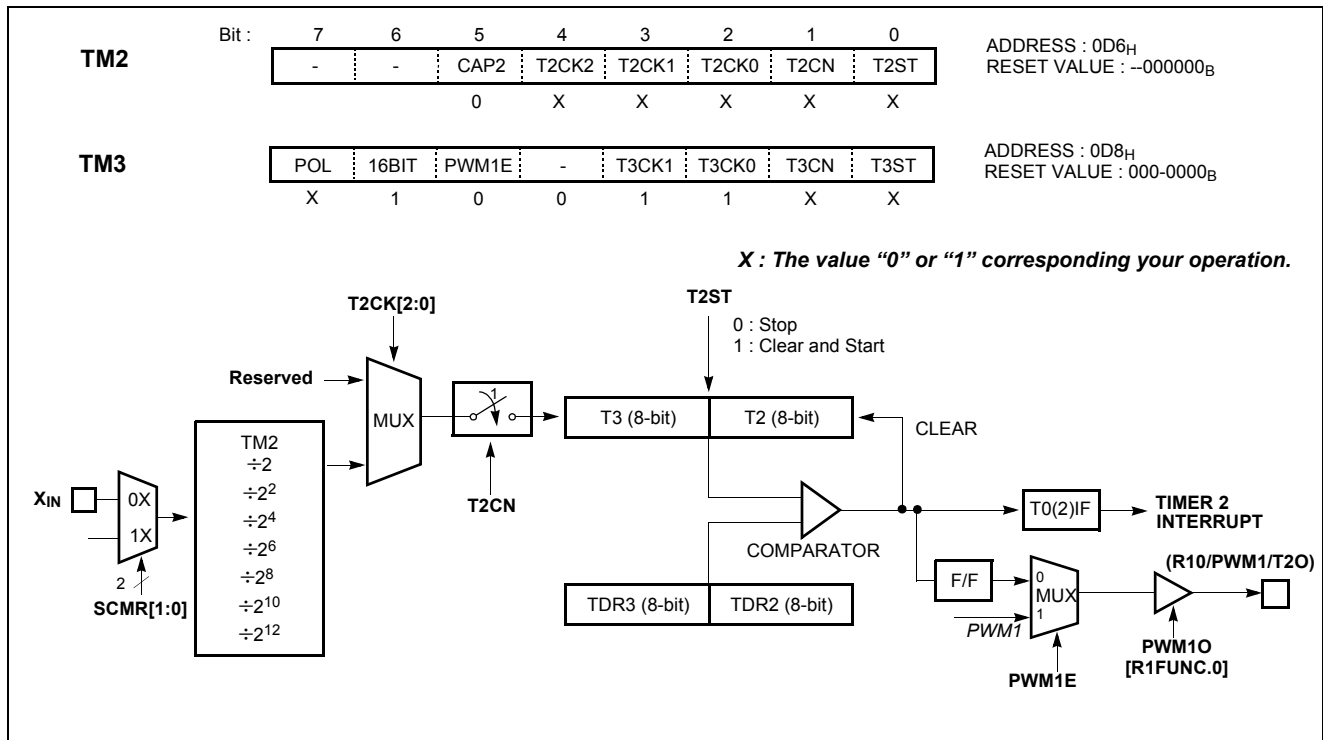

Figure 12-9 16-bit Timer / Counter Mode 2

12.3 8-Bit Capture Mode

The Timer 0 capture mode is set by bit CAP0 of timer mode register TM0 (bit CAPx of timer mode register TMx for Timer 1,2,3) as shown in Figure 12-10.

As mentioned above, not only Timer 0 but Timer 1,2,3 can also be used as a capture mode.

The Timer/Counter register is increased in response internal or external input. This counting function is same with normal timer mode, and Timer interrupt is generated when timer register T0 (T1,2,3) increases and matches TDR0 (TDR1,TDR2,TDR3).

This timer interrupt in capture mode is very useful when the pulse width of captured signal is more wider than the maximum period of Timer.

For example, in Figure 12-13, the pulse width of captured signal is wider than the timer data value (FF_H) over 2 times. When external interrupt is occurred, the captured value (13_H) is more little than wanted value. It can be obtained correct value by counting the number of timer over-

flow occurrence.

Timer/Counter still does the above, but with the added feature that a edge transition at external input INTx pin causes the current value in the Timer x register (T0,T1,T2,T3), to be captured into registers CDRx (x=0,1,2,3), respectively. After captured, Timer x register is cleared and restarts by hardware.

It has three transition modes: “falling edge”, “rising edge”, “both edge” which are selected by interrupt edge selection register IEDS (Refer to External interrupt section). In addition, the transition at INTx pin generate an interrupt.

Note: *The CDR0, TDR0 and T0 are in same address. In the capture mode, reading operation is to read the CDR0 and in timer mode, reading operation is read the T0. TDR0 is only for writing operation. The CDR1, T1 are in same address, the TDR1 is located in different address. In the capture mode, reading operation is to read the CDR1*

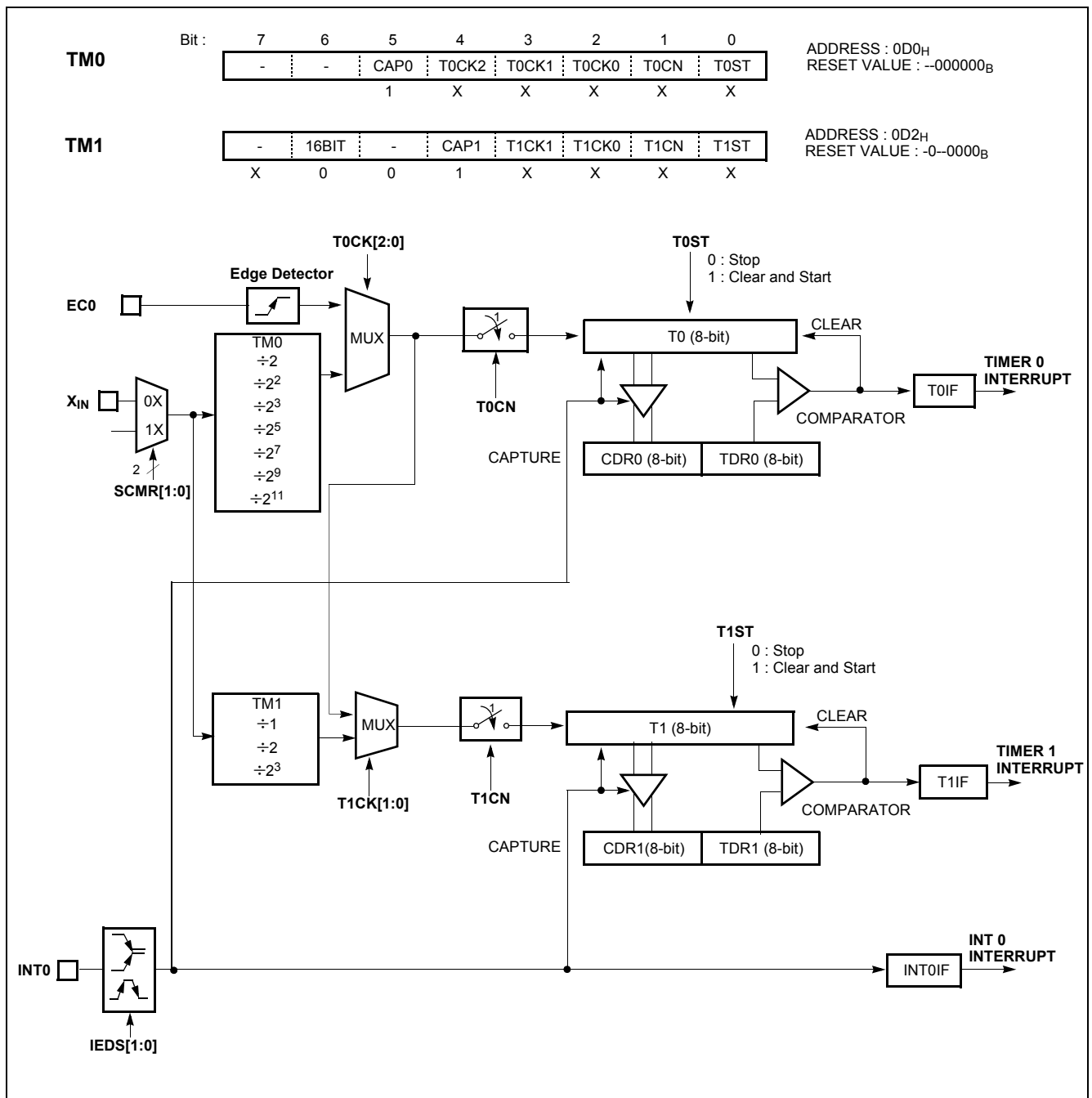

Figure 12-10 8-bit Capture Mode (Timer0, Timer1)

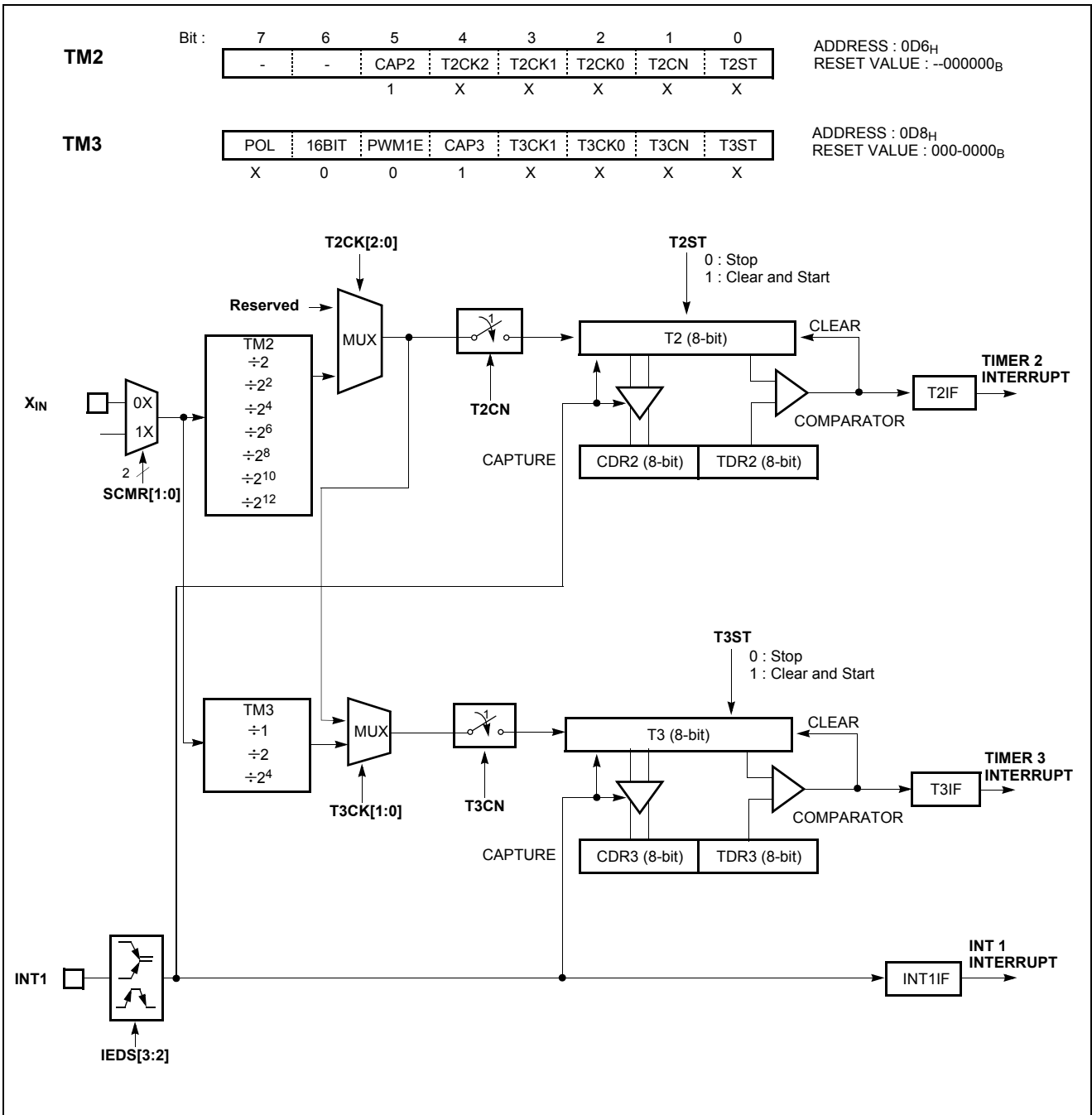

Figure 12-11 8-bit Capture Mode (Timer2, Timer3)

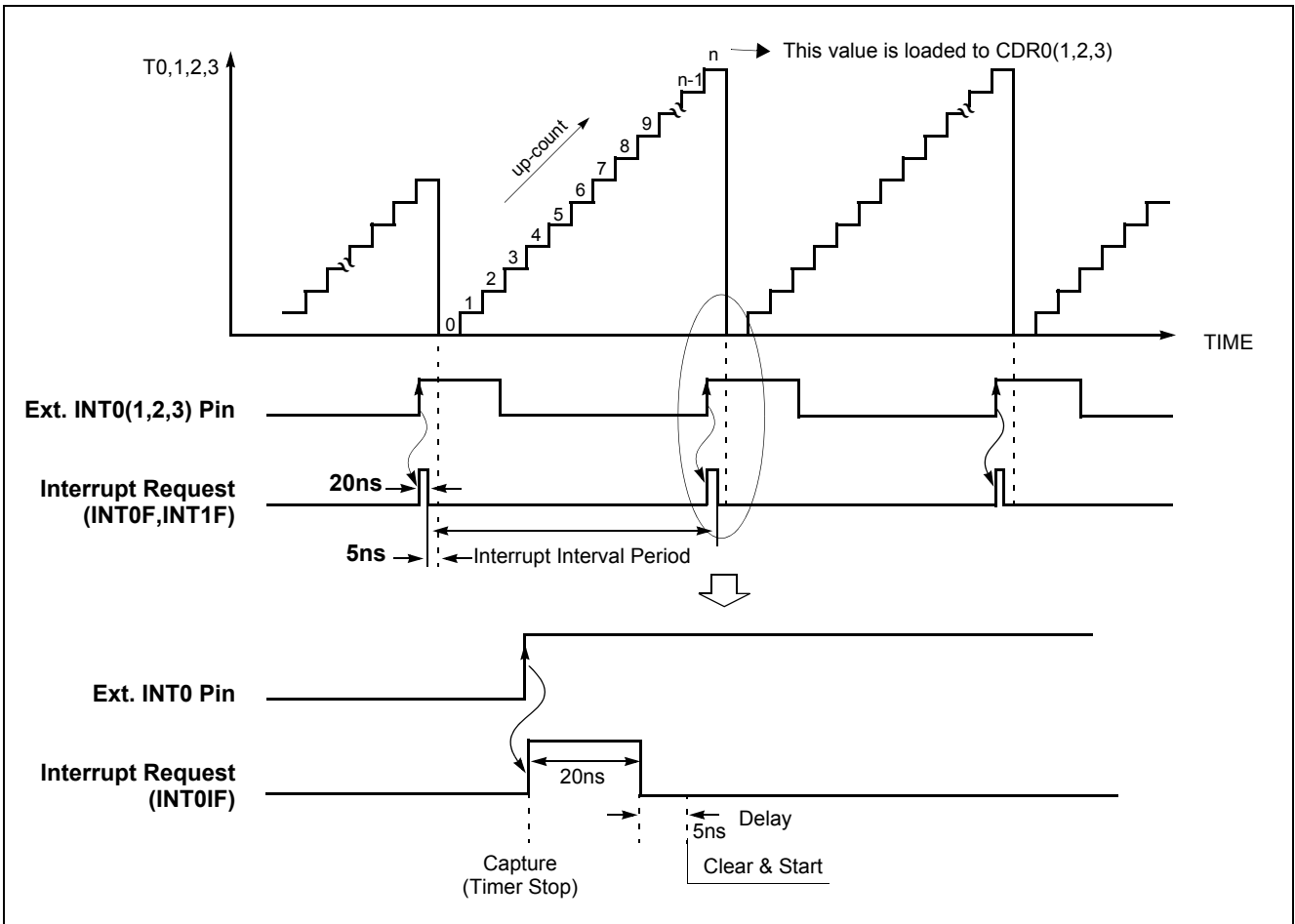

Figure 12-12 Input Capture Operation

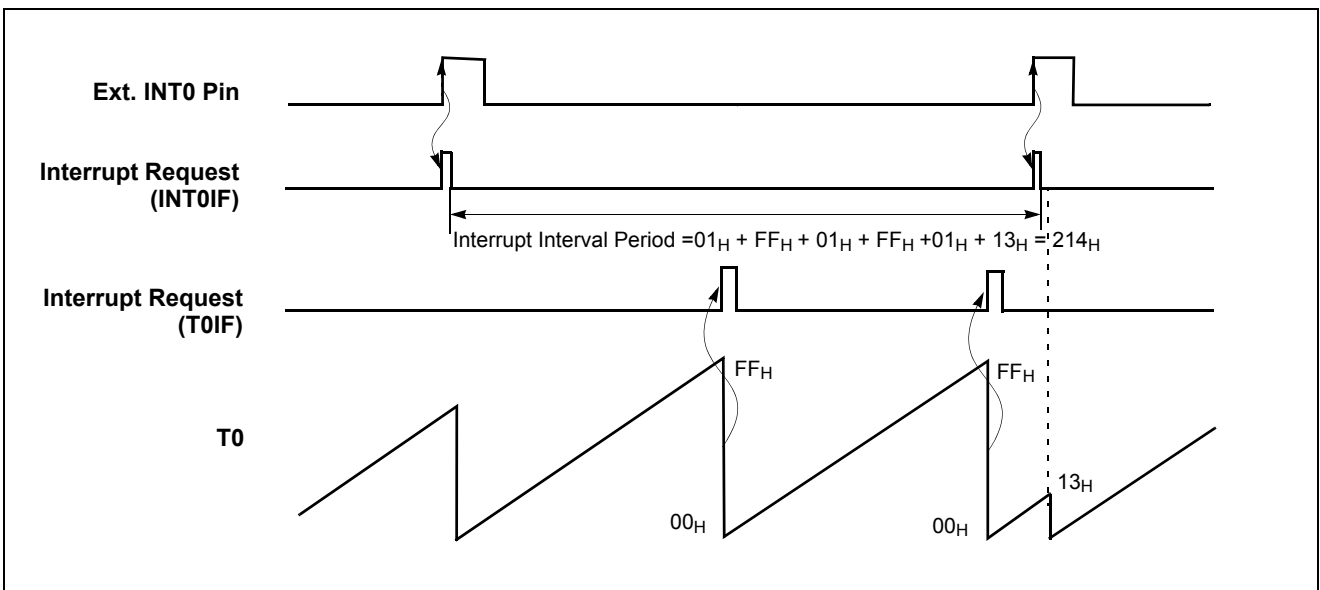

Figure 12-13 Excess Timer Overflow in Capture Mode

12.4 16-bit Capture Mode

16-bit capture mode is the same as 8-bit capture, except that the Timer register is running with 16 bits.

In 16-bit mode, the bits TxCK1, TxCK0 and 16BIT of TM1, TM3 should be set to "1" respectively.

The clock source of the Timer 0,2 is selected either internal or external clock by bit TxCK2, TxCK1 and TxCK0.

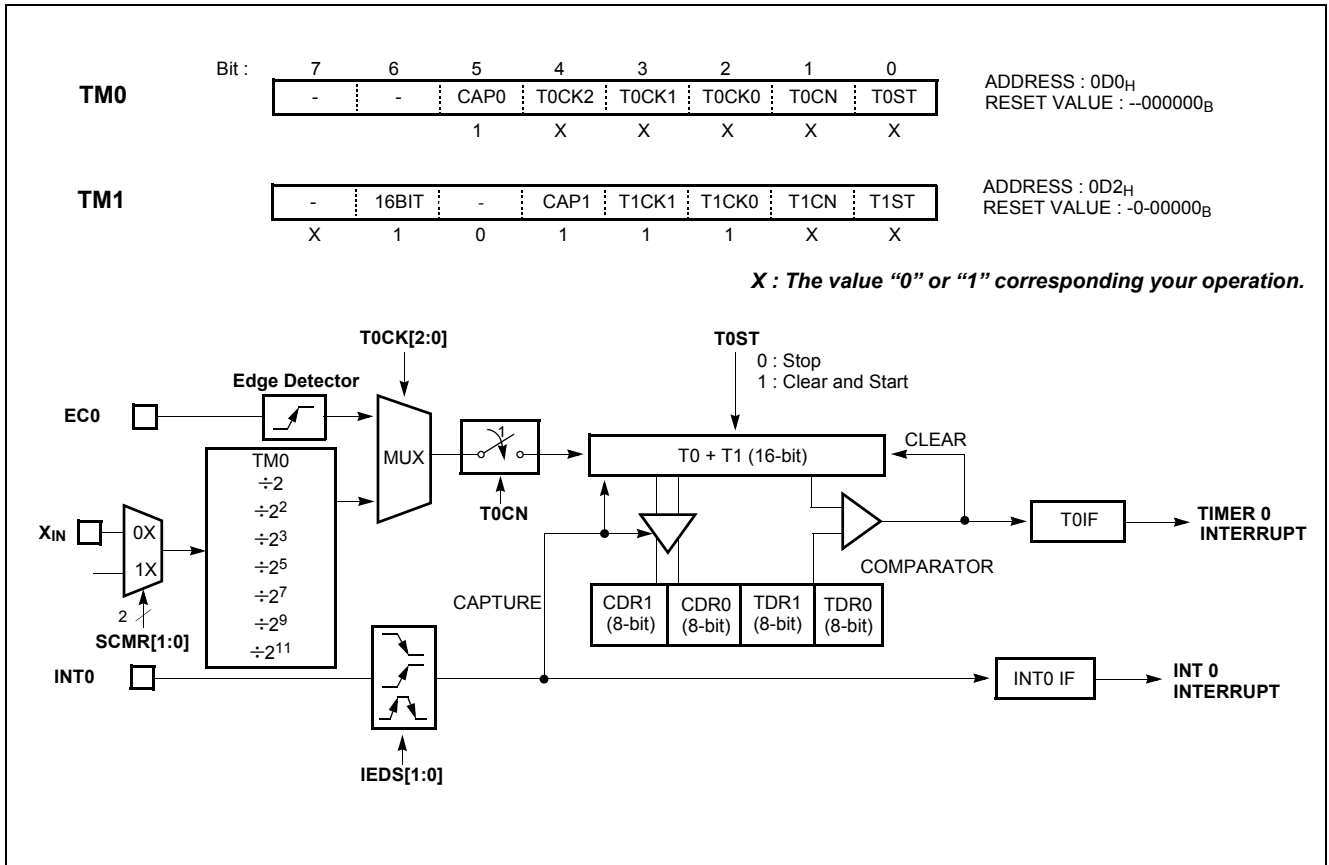

Figure 12-14 16-bit Capture Mode (Timer0,1)

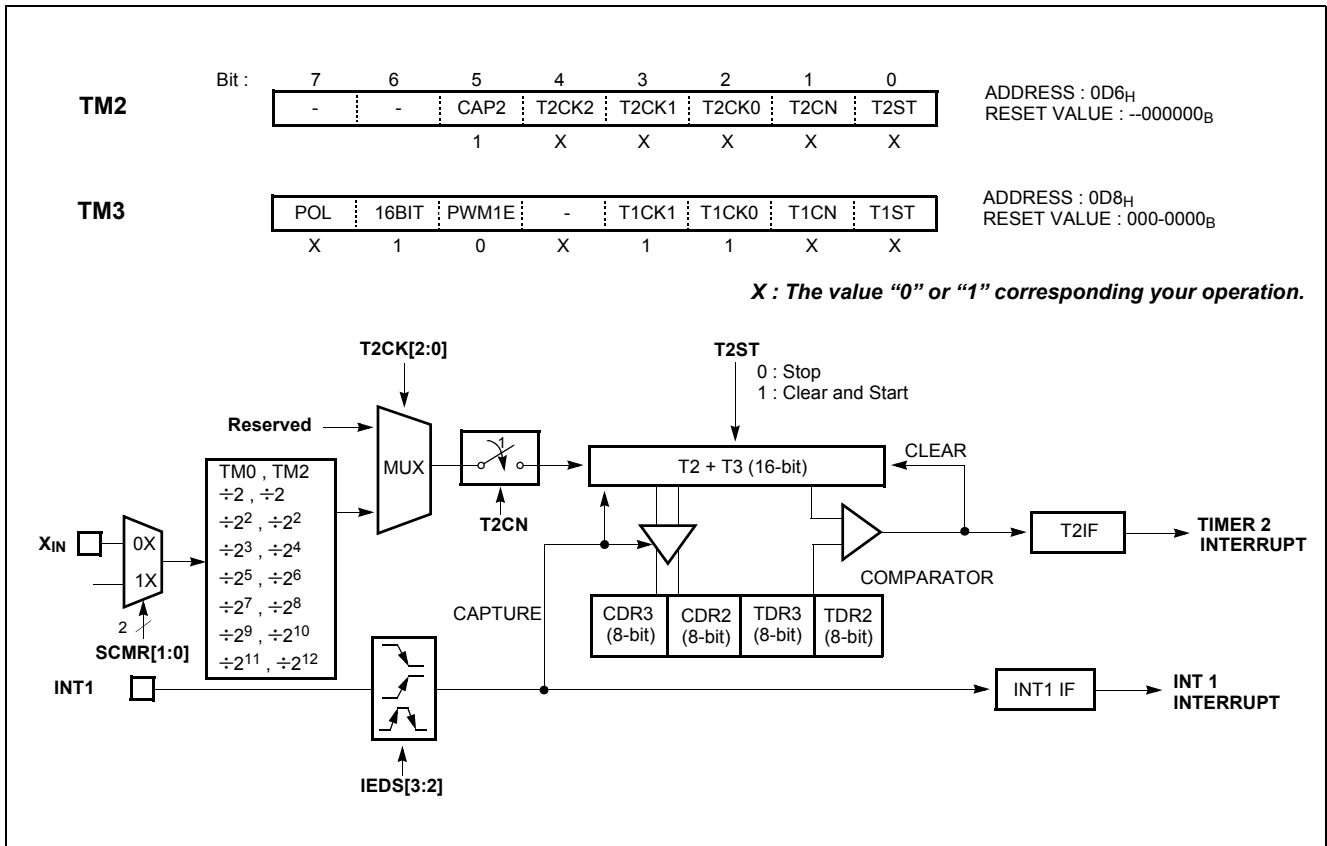

Figure 12-15 16-bit Capture Mode (Timer2,3)

12.5 8-Bit (16-Bit) Compare Output Mode

The MC80F7708A have a function of Timer Compare Output. To pulse out, the timer match can goes to port pin (R10) as shown in Figure 12-4 and Figure 12-8. Thus, pulse out is generated by the timer match. These operation is implemented to pin, R10/PWM1/T2O.

In this mode, the bit PWM10 of Port Mode Register R1FUNC should be set to "1", and the bit PWM1E of Timer3 Mode Register (TM3) should be cleared to "0".

12.6 PWM Mode

The MC80F7708A has one high speed PWM (Pulse Width Modulation) function which shared with Timer3. In PWM mode, the R10/PWM1 pins operate as a 10-bit resolution PWM output port. For this mode, the bit PWM10 of Port Mode Register (R1FUNC) and the bit PWM1E of timer3 mode register (TM3) should be set to "1" respectively.

The period of the PWM output is determined by the T3PPR (T3 PWM Period Register) and T3PWHR[3:2] (bit3, 2 of T3 PWM High Register) and the duty of the PWM output is determined by the T3PDR (T3 PWM Duty

In addition, 16-bit Compare output mode is available, also. This pin output the signal having a 50: 50 duty square wave, and output frequency is same as below equation

$$f_{COMP} = \frac{f_{XIN}}{2 \times PrescalerValue \times (TDR + 1)}$$

Register) and T3PWHR[1:0] (bit1, 0 of T3PWM High Register).

The user can use PWM data by writing the lower 8-bit period value to the T3PPR and the higher 2-bit period value to the T3PWHR[3:2]. And the duty value can be used with the T3PDR and the T3PWHR[1:0] in the same way.

The T3PDR is configured as a double buffering for glitchless PWM output. In Figure 12-16, the duty data is transferred from the master to the slave when the period data matched to the counted value. (i.e. at the beginning of next

duty cycle).

The bit POL1 of TM3 decides the polarity of duty cycle.

The duty value can be changed when the PWM outputs. However the changed duty value is output after the current period is over. And it can be maintained the duty value at present output when changed only period value shown as Figure 12-18. As it were, the absolute duty time is not changed in varying frequency.

Note: If the user need to change mode from the Timer3 mode to the PWM mode, the Timer3 should be stopped firstly, and then set period and duty register value. If user writes register values and changes mode to PWM mode while Timer3 is in operation, the PWM data would be different from expected data in the beginning.

The relation of frequency and resolution is in inverse proportion. Table 12-2 shows the relation of PWM frequency vs. resolution.

PWM Period = $[T3PWHR[3:2]T3PPR+1] X$ Source Clock

PWM Duty = $[T3PWHR[1:0]T3PDR+1] X$ Source Clock

If it needed more higher frequency of PWM, it should be reduced resolution.

Note: If the duty value and the period value are same, the PWM output is determined by the bit POL1 (1: High, 0: Low). And if the duty value is set to "00H", the PWM output is determined by the bit POL1 (1: Low, 0: High). The period value must be same or more than the duty value, and 00H cannot be used as the period value.

Resolution	Frequency		
	T3CK[1:0] =00 (250nS)	T3CK[1:0] =01 (500nS)	T3CK[1:0] =10 (2uS)
10-bit	3.9kHz	1.95kHz	0.49kHz
9-bit	7.8kHz	3.9kHz	0.98kHz
8-bit	15.6kHz	7.8kHz	1.95kHz
7-bit	31.2kHz	15.6kHz	3.90kHz

Table 12-2 PWM Frequency vs. Resolution at 4MHz

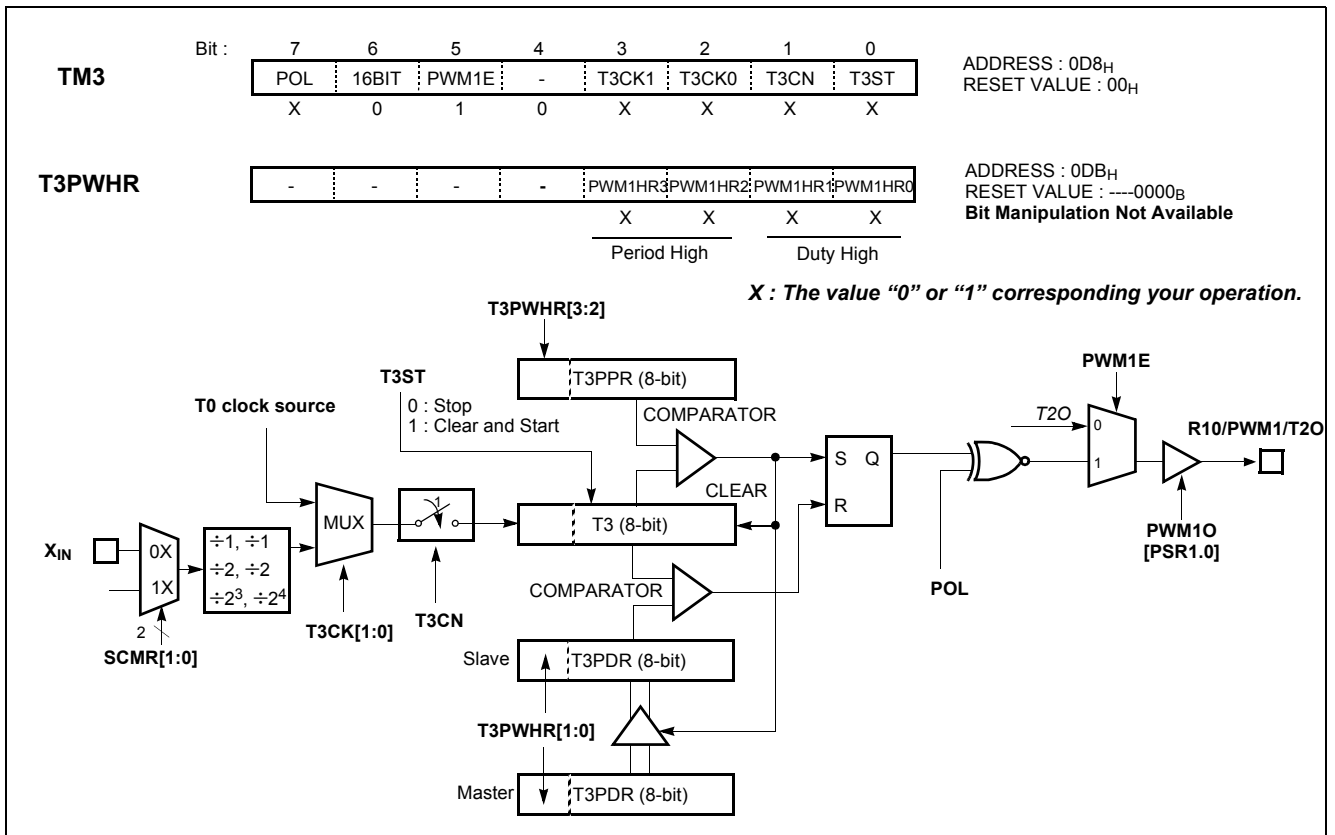

Figure 12-16 PWM Mode

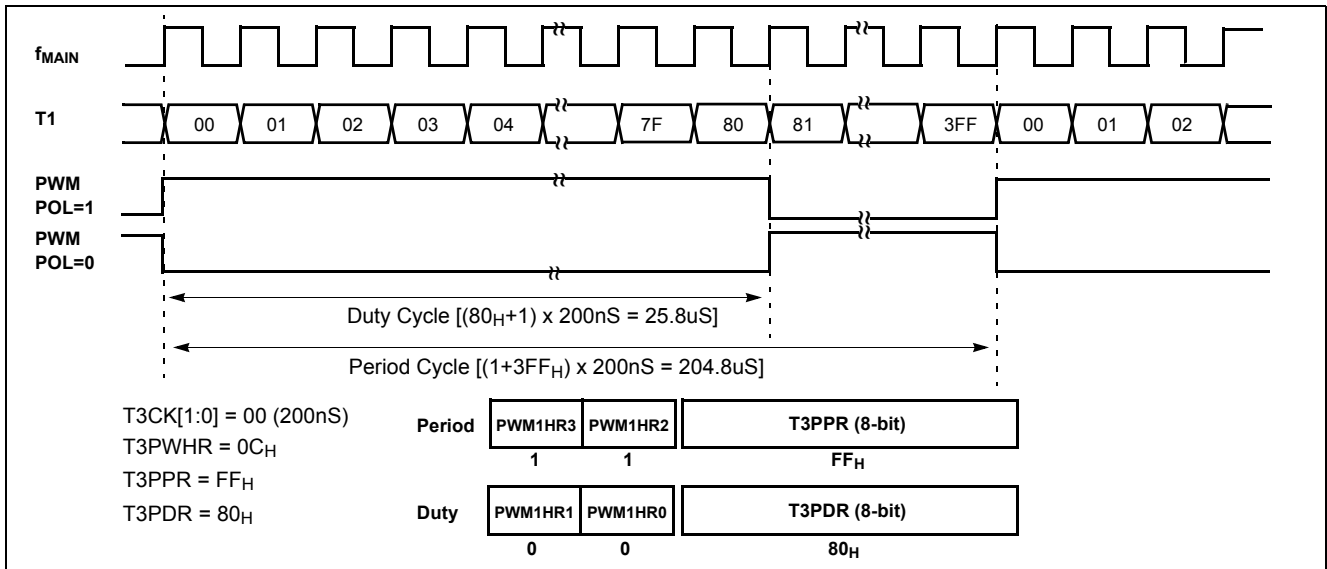

Figure 12-17 Example of PWM at 5MHz

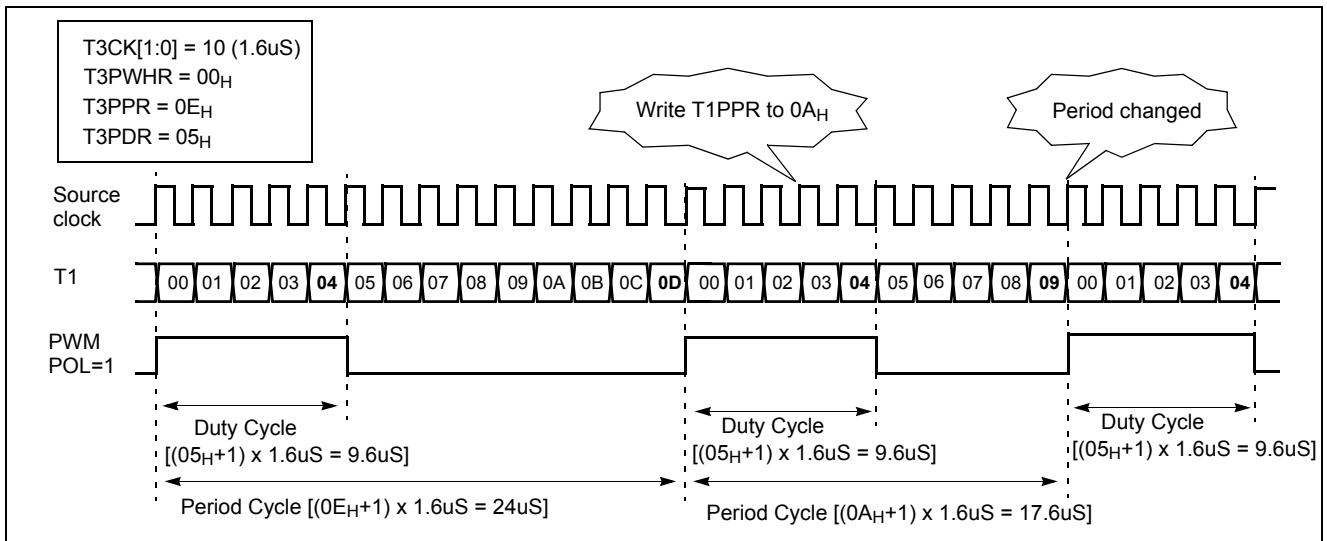

Figure 12-18 Example of Changing the Period in Absolute Duty Cycle (@5MHz)

Example:

Timer1 @4Mhz, 4kHz - 20% duty PWM mode

```

LDM R1IO, #0000_XXX1B ;R00 output
LDM TM3, #0010_0000B ;pwm enable
LDM T3PWHR, #0000_1100B ;20% duty
LDM T3PPR, #1110_0111B ;period 250uS
LDM T3PDR, #1100_0111B ;duty 50uS
LDM PSR1, #XXXX_XXX1B ;set pwm port.
LDM TM3, #0010_0011B ;timer1 start
    
```

X means don't care

13. WATCH TIMER

The watch timer generates interrupt for watch operation. The watch timer consists of the clock selector, 21-bit binary counter and watch timer mode register. It is a multi-purpose timer. It is generally used for watch design.

The bit 0, 1, 2 of WTMR select the clock source of watch timer among sub-clock, $f_{MAIN} \div 2^8$, $f_{MAIN} \div 2^7$, f_{MAIN} or $f_{MAIN} \div 2$ of main-clock and f_{MAIN} of main-clock. The f_{MAIN} of main-clock is used usually for watch timer test, so generally it is not used for the clock source of watch timer. The $f_{MAIN} \div 2^7$ or $f_{MAIN} \div 2^8$ clock is used when the single clock system is organized. If $f_{MAIN} \div 2^8$ or $f_{MAIN} \div 2^7$ clock is used as watch timer clock source, when the CPU enters into stop mode, the main clock is stopped and then watch timer is also stopped. If the sub-clock is used as the watch timer source clock, the watch timer count cannot be stopped. Therefore, the sub-clock does not stop and continues to oscillate even when the CPU is in the STOP mode. The timer counter consists of 21-bit binary counter and it

can count to max 60 seconds at sub-clock.

The bit 3, 4 of WTMR select the interrupt request interval of watch timer among 2Hz, 4Hz, 16Hz and 1/64Hz.

Note: The Clock source of watch timer is also applied to LCD driver clock source. When selecting LCD driver clock source, the WTCK[2:0] should be set to appropriate value.

Note: Interrupt request flag(WTIF) must be erased after maximum 40us instruction executing time at watch timer interrupt service routine because it is may not cleared itself during interrupt acceptance processing. In case of releasing STOP mode, internal WTIF signal is not cleared for next sub-clock(0~30.5us at 32.768kHz).

WTRH (Watch Timer Read High Register)

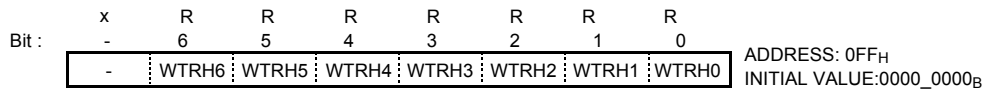

WTRH[6:0]: (WT data capture Value)

WTR (Watch Timer Register)

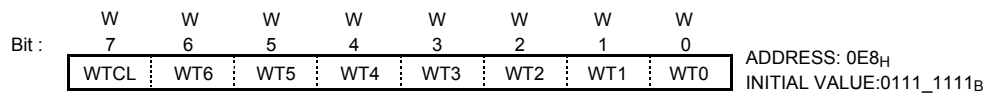

WTCL (WT Clear)

0: Free Run
1: WT Clear(Auto clear after 1cycle)

WT[6:0] (WT Interrupt Interval Value)

WT Interrupt Interval(IFWT) = (fwck/2¹⁴) x (7bit WT Value+1)

WTMR (Watch Timer Mode Register)

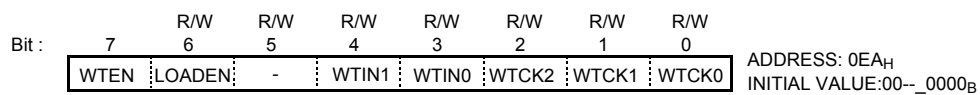

WTEN (Watch Timer Enable Bit)

0: Watch Timer Disable
1: Watch Timer Enable

LOADEN (7bit reload Counter Write Enable Bit)

0: Watch Dog Timer Write Enable
1: Watch Timer Write Enable

WTIN[1:0] (Watch Timer Interrupt Interval Selection)

00: $f_{wck} / 2^{11}$ [16Hz]*
01: $f_{wck} / 2^{13}$ [4Hz]*
10: $f_{wck} / 2^{14}$ [2Hz]*
11: $f_{wck} / 2^{14} \times (7\text{bit WT value}+1)$ [2Hz x (7bit WT value+1)]*

WTCK[2:0] (Watch Timer Clock Source Selection) : fwck

000: Sub. Clock (f_{SUB})
001: Main Clock (f_{MAIN}÷2⁸)
010: Main Clock (f_{MAIN}÷2⁷)
011: Main Clock (f_{MAIN})
100: Main Clock (f_{MAIN}÷2)

* When f_{SUB} = 32.768 kHz and f_{MAIN} = 4.19 MHz (f_{MAIN} ÷ 2⁷)

f_{MAIN}: main-clock frequency at main-active mode
sub-clock frequency at sub-active mode

Example:

; 1 minute watch timer interrupt selection

```
LDM WTMR, #1101_1000B ; T = 1/fSUB x 214 x (count+1)
LDM WTR, #1111_0111B ; 080h + 119(count)
```

Figure 13-1 Watch Timer Mode Register

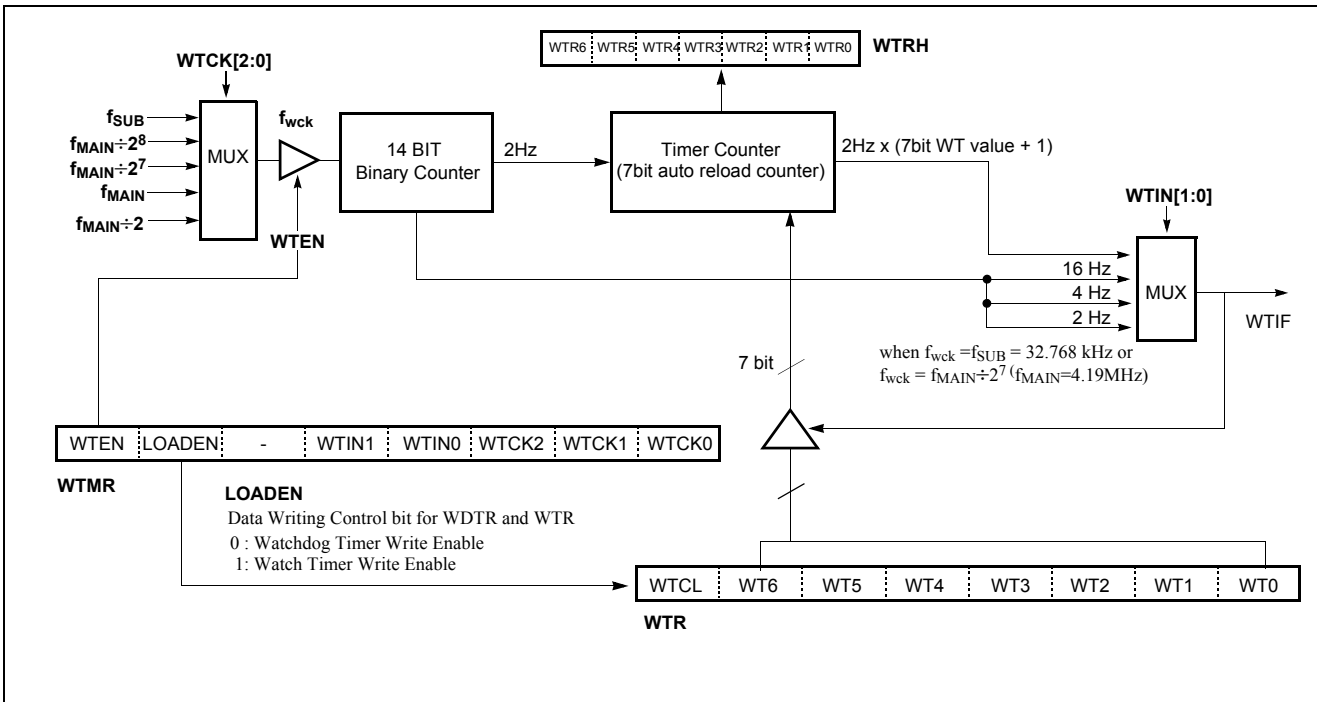

Figure 13-2 Watch Timer Block Diagram

Usage of Watch Timer in STOP Mode

When the system is off and the watch should be kept working, follow the steps below.

1. Set the clock source of watch timer to sub-clock.
2. Enters into STOP mode.
3. After released by watch timer interrupt, counts up timer and refreshes LCD Display. When performing count up and refresh the LCD, the CPU operates in main frequency mode. **And clear WTIF approximately after maximum 40us delay time. If WTIF is not cleared by**

software, watch timer interrupt may be happened twice because internal WTIF signal is set during next input clock.

4. Enters into STOP mode again.
5. Repeats 3 and 4.

When using STOP mode, if the watch timer interrupt interval is selected to 2Hz, the power consumption can be reduced considerably.

14. WATCH DOG TIMER

The watch dog timer (WDT) function is used for checking program malfunction due to external noise or other causes and return the operation to the normal contion.

The watchdog timer consists of 7-bit binary counter and the watchdog timer register(WDTR). The source clock of WDT is overflow of Basic Interval Timer. When the value of 7-bit binary counter is equal to the lower 7-bits of WDTR, the interrupt request flag is generated. This can be used as WDT interrupt or CPU reset signal in accordance with the bit WDTON. When WDTCL is set, 7-bit counter of WDT is reset. After one cycle, it is cleared by hardware.

When writing WDTR, the LOADEN bit of WTMR regis-

ter should be cleared to “0”.

Note: *WDTR and WTR has same address 0E8h. The LOADEN bit is used to select WDTR or WTR. When LOADEN of watch timer mode register(WTMR) is set to “1”, WDTR can not be wrote and WTR is wrote. The LOADEN bit should be cleared to “0” when writing any value to WDTR.*

Note: *When using watch dog timer, don't write WDT[6:0] to “000000”.*

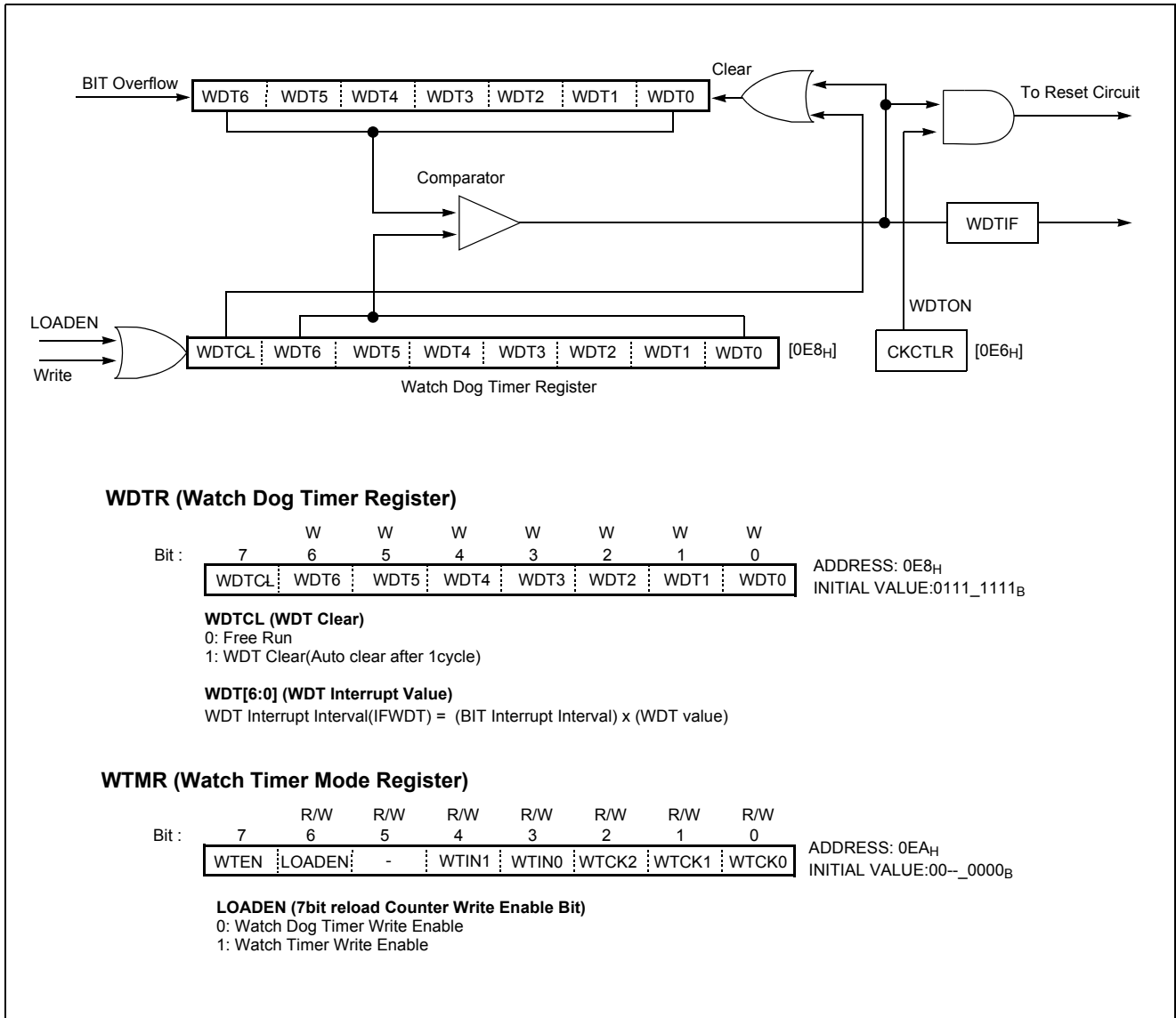

Figure 14-1 Block Diagram of Watch Dog Timer

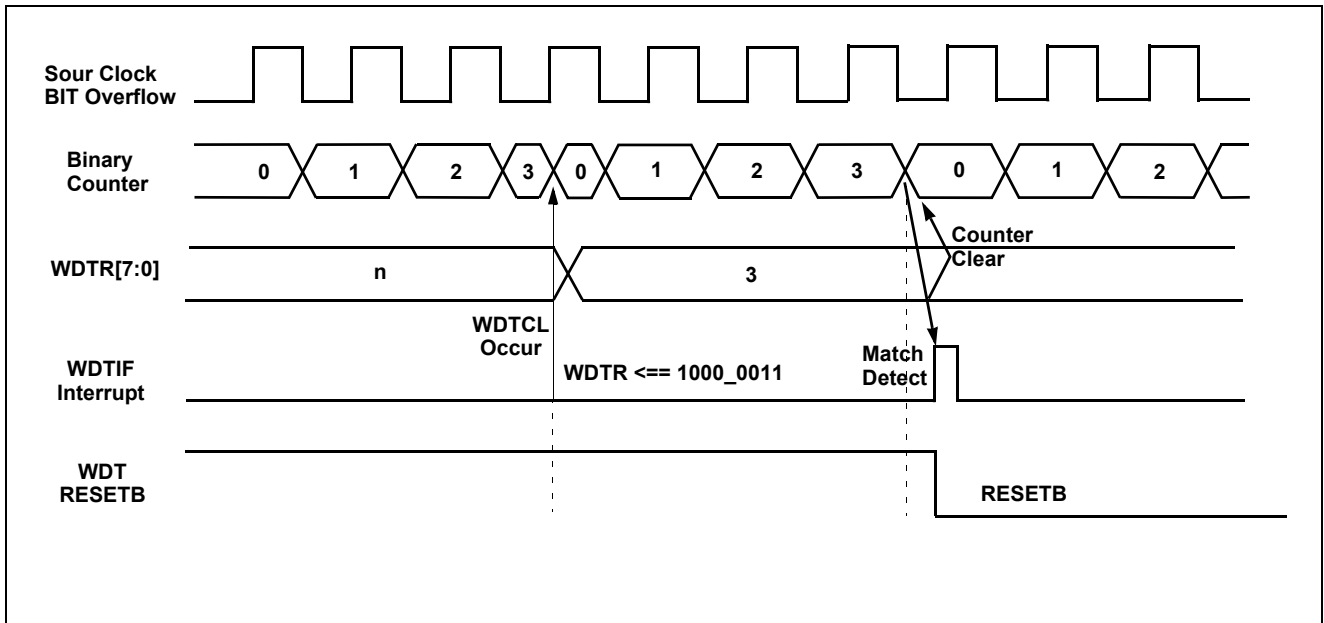

Figure 14-2 Watch Dog Timer Interrupt Time

15. ANALOG TO DIGITAL CONVERTER

The analog-to-digital(A/D) converter allows conversion of an analog input signal to an corresponding 8-bit digital value. The A/D module has six analog inputs, which are multiplexed into one sample and hold. The output of the sample and hold is the input of the converter, which generates the result via successive approximation. The analog supply voltage is connected to V_{DD} of ladder resistance of A/D module.

The A/D module has three registers which are the control register ADCM and A/D result register ADCRL. The ADCM register, shown in Figure 15-2, controls the operation of the A/D converter module. The port pins can be configured as analog inputs or digital I/O. To use analog inputs, each port should be assigned analog input port by

setting R2IO direction register as input mode and setting ADS[2:0] to select the corresponding channel.

The processing of conversion is start when the start bit ADST is set to "1". After one cycle, it is cleared by hardware. The register ADCRL contain the result of the A/D conversion. ADCRL contains the result of the A/D conversion. When the conversion is completed, the result is loaded into the ADCRL, the A/D conversion status bit ADF is set to "1". The block diagram of the A/D module is shown in Figure 15-1. The A/D status bit ADF is automatically set when A/D conversion is completed, cleared when A/D conversion is in process. The conversion time takes maximum 10uS(at $f_{XIN}=8\text{MHz}$).

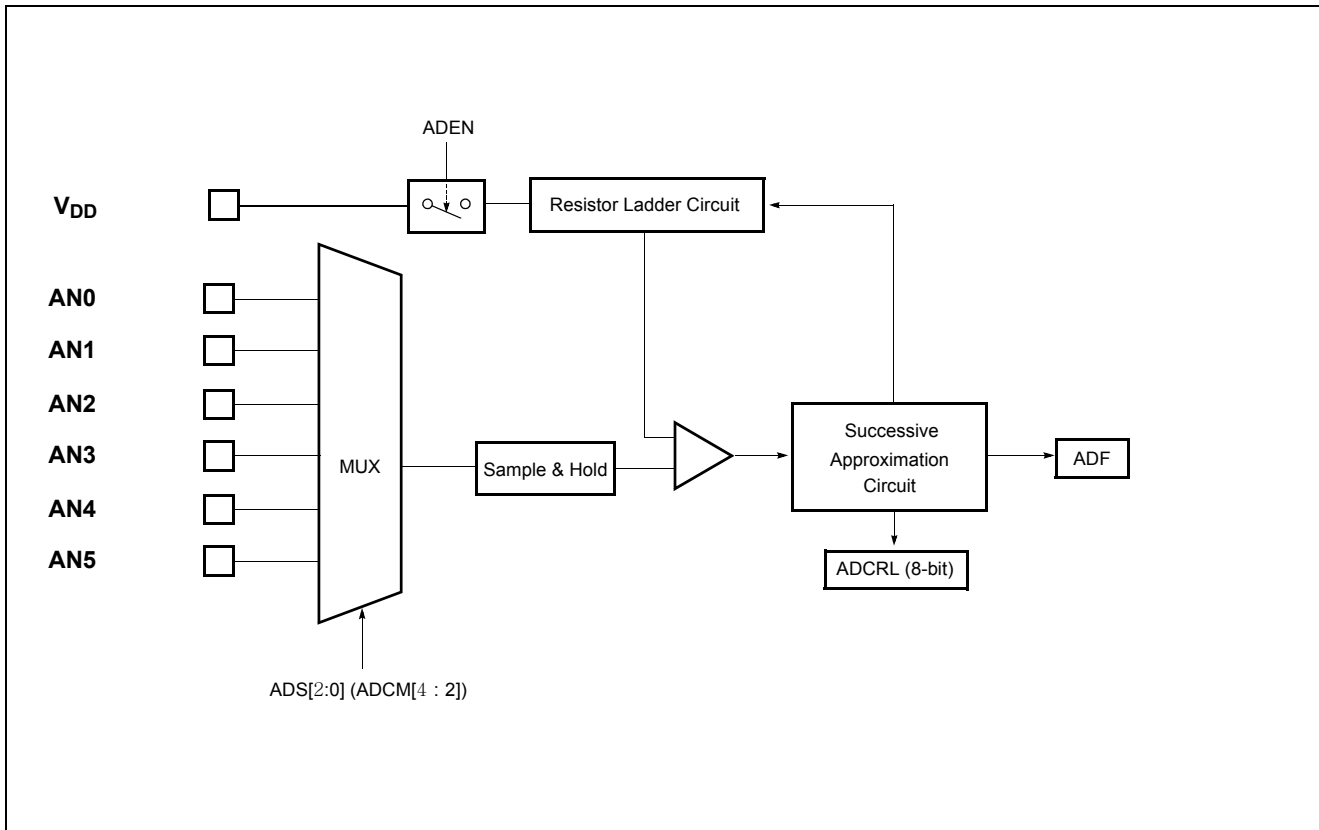

Figure 15-1 A/D Converter Block Diagram & Registers

ADCM (A/D Converter Mode Register)

	R/W				R/W	R/W	R/W	R
Bit :	7	6	5	4	3	2	1	0
	ADEN	1	0	ADS2	ADS1	ADS0	ADST	ADF

ADDRESS : 0E2_H
RESET VALUE : -0-00001_B

ADEN (A/D Converter Enable bit)

1 : Enable
0 : Disable

ADST (A/D Start bit)

1 : A/D Conversion is started
After 1 cycle, cleared to "0"
0 : Bit force to zero

ADF (A/D Status bit)

0 : A/D Conversion is in process
1 : A/D Conversion is completed

ADS[2:0] (A/D Converter Input Selection)

000 : Channel 0 (R20/AN0)
001 : Channel 1 (R21/AN1)
010 : Channel 2 (R22/AN2)
011 : Channel 3 (R23/AN3)
100 : Channel 4 (R24/AN4)
101 : Channel 5 (R25/AN5)
110 : Reserved
111 : Reserved

Note : R24/AN4 and R25/AN5 are not supported in MC80F7708AK/AD.

ADCRH (A/D Converter Result High Register: EVA only)

	W	W	W	R	R	R	R	R
Bit :	7	6	5	4	3	2	1	0
	0	0	1	-	-	-	-	-

ADDRESS : 0E4_H
RESET VALUE : Undefined

* Unused bit of ADCRH should be set as

Bit7 : "0"
Bit6 : "0"
Bit5 : "1"

ADCRL (A/D Converter Result Low Register)

	R	R	R	R	R	R	R	R
Bit :	7	6	5	4	3	2	1	0
	ADR7	ADR6	ADR5	ADR4	ADR3	ADR2	ADR1	ADR0

ADDRESS : 0E3_H
RESET VALUE : Undefined

*The conversion time takes maximum 10us at 8MHz and 20us at 4MHz.

Figure 15-2 A/D Converter Mode & Result Registers

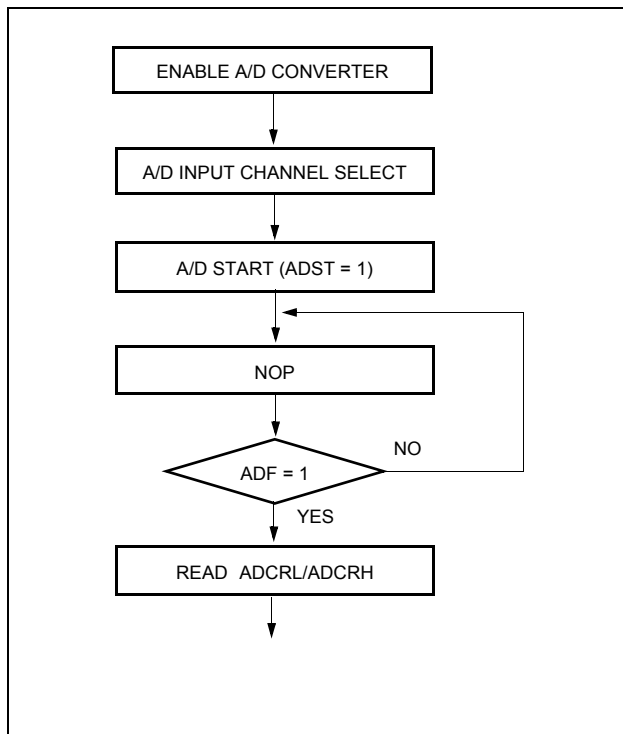

Figure 15-3 A/D Converter Operation Flow

A/D Converter Cautions

(1) Input range of AN0 to AN5

The input voltages of AN0 to AN7 should be within the specification range. In particular, if a voltage above V_{DD} or below V_{SS} is input (even if within the absolute maximum rating range), the conversion value for that channel can not be determined. The conversion values of the other channels may also be affected.

(2) Noise counter measures

In order to maintain 8-bit resolution, any attention must be paid to noise on pins AV_{DD} and AN0 to AN7. Since the effect increases in proportion to the output impedance of the analog input source, it is recommended that a capacitor is connected externally as shown below in order to reduce noise.

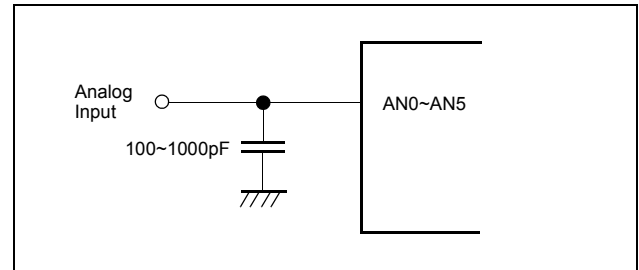

Figure 15-4 Analog Input Pin Connecting Capacitor

(3) Pins AN0/R20 to AN5/R25

The analog input pins AN0 to AN5 also function as input/output port (PORT R2) pins. When A/D conversion is performed with any of pins AN0 to AN57 selected, be sure not to execute a PORT input instruction while conversion is in progress, as this may reduce the conversion resolution.

Also, if digital pulses are applied to a pin adjacent to the pin in the process of A/D conversion, the expected A/D conversion value may not be obtainable due to coupling noise. Therefore, avoid applying pulses to pins adjacent to the pin undergoing A/D conversion.

(4) AV_{DD} pin input impedance

A series resistor string of approximately $10K\Omega$ is connected between the AV_{DD} pin and the V_{SS} pin.

Therefore, if the output impedance of the reference voltage source is high, this will result in parallel connection to the series resistor string between the AV_{DD} pin and the V_{SS} pin, and there will be a large reference voltage error.

16. BUZZER OUTPUT FUNCTION

The buzzer driver consists of 6-bit binary counter, the buzzer driver register BUZR and the clock selector. It generates square-wave which is very wide range frequency (500 Hz~125 kHz at $f_{MAIN} = 4\text{MHz}$) by user programmable counter.

Pin R04/BUZO is assigned for output port of Buzzer driver by setting the bit BUZO of R0 Function Register(R0FUNC) to "1".

The 6-bit buzzer counter is cleared and start the counting by writing signal to the register BUZR. It is increased from 00H until it matches with BUR[5:0].

Also, it is cleared by counter overflow and count up to output the square wave pulse of duty 50%.

The bit 0 to 5 of BUZR determines output frequency for

buzzer driving. BUZR[5:0] is initialized to 3FH after reset. Note that BUZR is a write-only register. Frequency calculation is following as shown below.

$$f_{BUZ} = \frac{f_{XIN}}{2 \times DivideRatio \times (BUZR[5:0] + 1)}$$

The bits BUCK1, BUCK0 of BUZR select the source clock from prescaler output.

- f_{BUZ} : Buzzer frequency
- f_{XIN} : Oscillator frequency
- Divide Ratio: Prescaler divide ratio by BUCK[1:0]
- BUZR[5:0]: Lower 6-bit value of BUZR. Buzzer control data

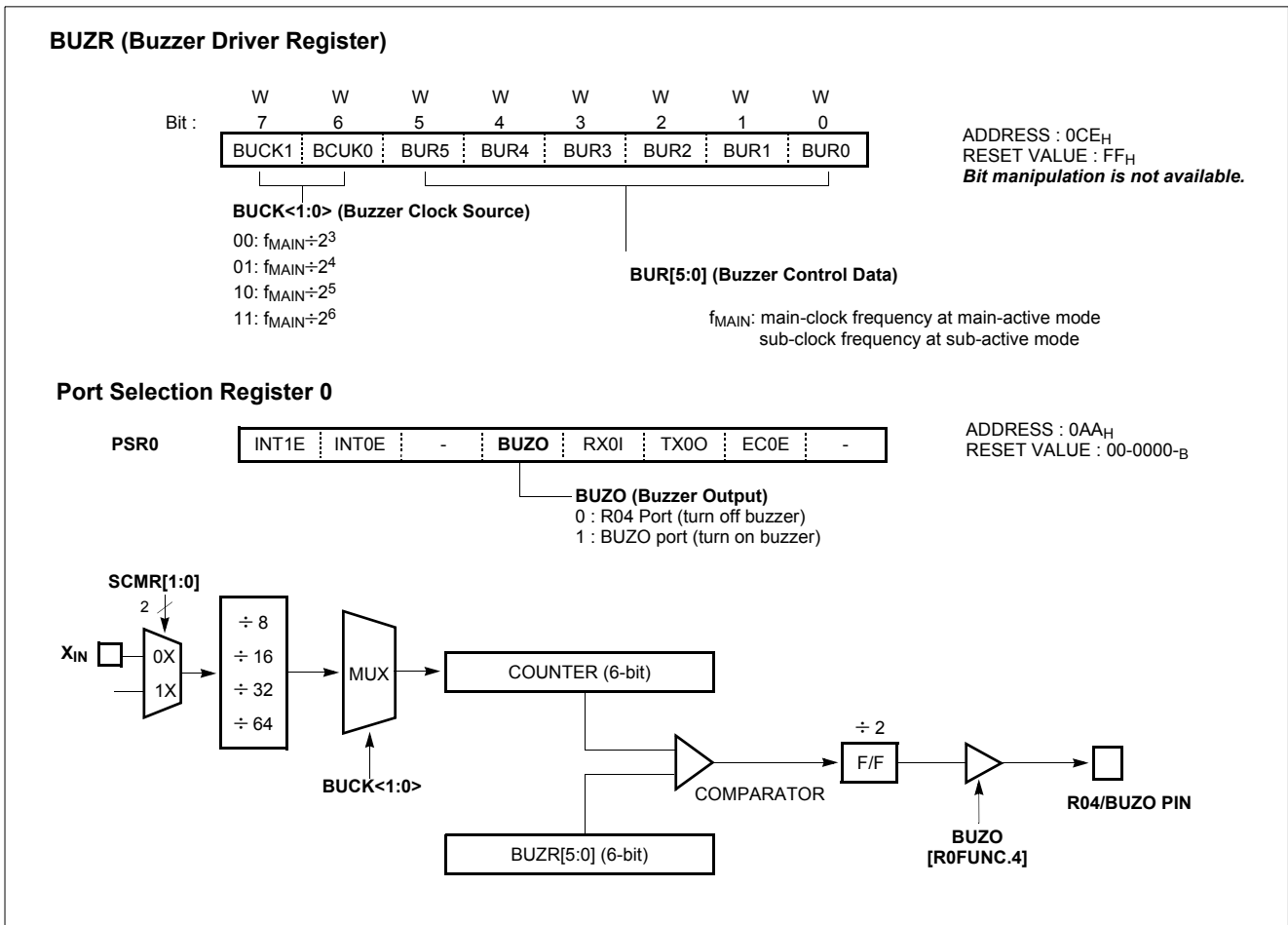

Figure 16-1 Buzzer Driver

Example: 2.5kHz output at 4MHz.

```
LDM R0FUNC, #XXX1_XXXXB
LDM BUZR, #1001_1000B
```

X means don't care

Buzzer Output Frequency

When main-frequency is 4MHz, buzzer frequency is shown as below.

BUZR [5:0]	Frequency Output (kHz) BUZR[7:6]				BUZR [5:0]	Frequency Output (kHz) BUZR[7:6]			
	00	01	10	11		00	01	10	11
00	250.000	125.000	62.500	31.250	20	7.576	3.788	1.894	0.947
01	125.000	62.500	31.250	15.625	21	7.353	3.676	1.838	0.919
02	83.333	41.667	20.833	10.417	22	7.143	3.571	1.786	0.893
03	62.500	31.250	15.625	7.813	23	6.944	3.472	1.736	0.868
04	50.000	25.000	12.500	6.250	24	6.757	3.378	1.689	0.845
05	41.667	20.833	10.417	5.208	25	6.579	3.289	1.645	0.822
06	35.714	17.857	8.929	4.464	26	6.410	3.205	1.603	0.801
07	31.250	15.625	7.813	3.906	27	6.250	3.125	1.563	0.781
08	27.778	13.889	6.944	3.472	28	6.098	3.049	1.524	0.762
09	25.000	12.500	6.250	3.125	29	5.952	2.976	1.488	0.744
0A	22.727	11.364	5.682	2.841	2A	5.814	2.907	1.453	0.727
0B	20.833	10.417	5.208	2.604	2B	5.682	2.841	1.420	0.710
0C	19.231	9.615	4.808	2.404	2C	5.556	2.778	1.389	0.694
0D	17.857	8.929	4.464	2.232	2D	5.435	2.717	1.359	0.679
0E	16.667	8.333	4.167	2.083	2E	5.319	2.660	1.330	0.665
0F	15.625	7.813	3.906	1.953	2F	5.208	2.604	1.302	0.651
10	14.706	7.353	3.676	1.838	30	5.102	2.551	1.276	0.638
11	13.889	6.944	3.472	1.736	31	5.000	2.500	1.250	0.625
12	13.158	6.579	3.289	1.645	32	4.902	2.451	1.225	0.613
13	12.500	6.250	3.125	1.563	33	4.808	2.404	1.202	0.601
14	11.905	5.952	2.976	1.488	34	4.717	2.358	1.179	0.590
15	11.364	5.682	2.841	1.420	35	4.630	2.315	1.157	0.579
16	10.870	5.435	2.717	1.359	36	4.545	2.273	1.136	0.568
17	10.417	5.208	2.604	1.302	37	4.464	2.232	1.116	0.558
18	10.000	5.000	2.500	1.250	38	4.386	2.193	1.096	0.548
19	9.615	4.808	2.404	1.202	39	4.310	2.155	1.078	0.539
1A	9.259	4.630	2.315	1.157	3A	4.237	2.119	1.059	0.530
1B	8.929	4.464	2.232	1.116	3B	4.167	2.083	1.042	0.521
1C	8.621	4.310	2.155	1.078	3C	4.098	2.049	1.025	0.512
1D	8.333	4.167	2.083	1.042	3D	4.032	2.016	1.008	0.504
1E	8.065	4.032	2.016	1.008	3E	3.968	1.984	0.992	0.496
1F	7.813	3.906	1.953	0.977	3F	3.906	1.953	0.977	0.488

Table 16-1 Buzzer Output Frequency

17. INTERRUPTS

The MC80F7708A interrupt circuits consist of Interrupt enable register (IENH, IENM, IENL), Interrupt request flag register (IRQH, IRQM, IRQL), Interrupt flag register (INTFH, INTFL), Interrupt Edge Selection Register (IEDS), priority circuit and Master enable flag (“I” flag of PSW). The interrupts are controlled by the interrupt master enable flag I-flag (bit 2 of PSW), the interrupt enable register and the interrupt request flag register except Power-on reset and software BRK interrupt. The configuration of interrupt circuit is shown in Figure 17-1 and interrupt priority is shown in Table 17-1.

Table 17-1 Vector Table

Reset/Interrupt	Symbol	Priority	Vector Addr.
Hardware Reset	RESET	0	FFFEH
External Int. 0	INTR0	1	FFFAH
External Int. 1	INTR1	2	FFF8H
External Int. 2	INTR2	3	FFF6H
External Int. 3	INTR3	4	FFF4H
-	-	-	-
-	-	-	-
Timer 0 Int.	T0	5	FFEEH
Timer 1 Int.	T1	6	FFECH
Timer 2 Int.	T2	7	FFEAH
Timer 3 Int.	T3	8	FFE8H
-	-	-	-
BIT Int.	BIT	10	FFE2H
Watch Dog timer int.	WDT	11	FFE0H
Watch timer int.	WT	12	FFE0H

Each bit of interrupt request flag registers (IRQH, IRQM, IRQL) in Figure 17-1 is set when corresponding interrupt condition is met. The interrupt request flags that actually generate external interrupts are bit INT0F, INT1F and INT2F in Register IRQH and INT3F in Register IRQL. The External Interrupts INT0, INT1, INT2 and INT3 can each be transition-activated (1-to-0, 0-to-1 and both transition). The RX0 and TX0 of UART0 Interrupts are generated by RX0IF and TX0IF which are set by finishing the reception and transmission of data.

The Timer 0,1,2 and Timer 3 Interrupts are generated by T0IF, T1IF, T2IF and T3IF, which are set by a match in

their respective timer/counter register.

The Basic Interval Timer Interrupt is generated by BITIF which is set by overflow of the Basic Interval Timer Register (BITR). The Watch dog Interrupt is generated by WDTIF which set by a match in Watch dog timer register (when the bit WDTON is set to “0”). The Watch Timer Interrupt is generated by WTIF which is set periodically according to the established time interval.

When an interrupt is generated, the bit of interrupt request flag register (IRQH, IRQM, IRQL) that generated it may not cleared itself during interrupt acceptance processing. After interrupt acceptance, it should be cleared in interrupt service routine.

Each bit of Interrupt flag register (INTFH, INTFL) is set when corresponding interrupt flag bit as well as interrupt enable bit are set. The bits of interrupt flag register are never cleared by the hardware although the service routine is vectored to. Therefore, the interrupt flag register can be used to distinguish a right interrupt source from two available ones in a vector address. For example, RX0 and TX0 which have the same vector address (FFF2H) may be distinguished by INTFH register.

Interrupt enable registers are shown in Figure 17-2. These registers are composed of interrupt enable bits of each interrupt source, these bits determine whether an interrupt will be accepted or not. When enable bit is “0”, a corresponding interrupt source is prohibited. Note that PSW contains also a master enable bit, I-flag, which disables all interrupts at once. When an interrupt is occurred, the I-flag is cleared and disable any further interrupt, the return address and PSW are pushed into the stack and the PC is vectored to.

In an interrupt service routine, any other interrupt may be serviced. The source(s) of these interrupts can be determined by polling the interrupt request flag bits. Then, the interrupt request flag bit(s) must be cleared by software before re-enabling interrupts to avoid recursive interrupts. The Interrupt Request flags are able to be read and written.

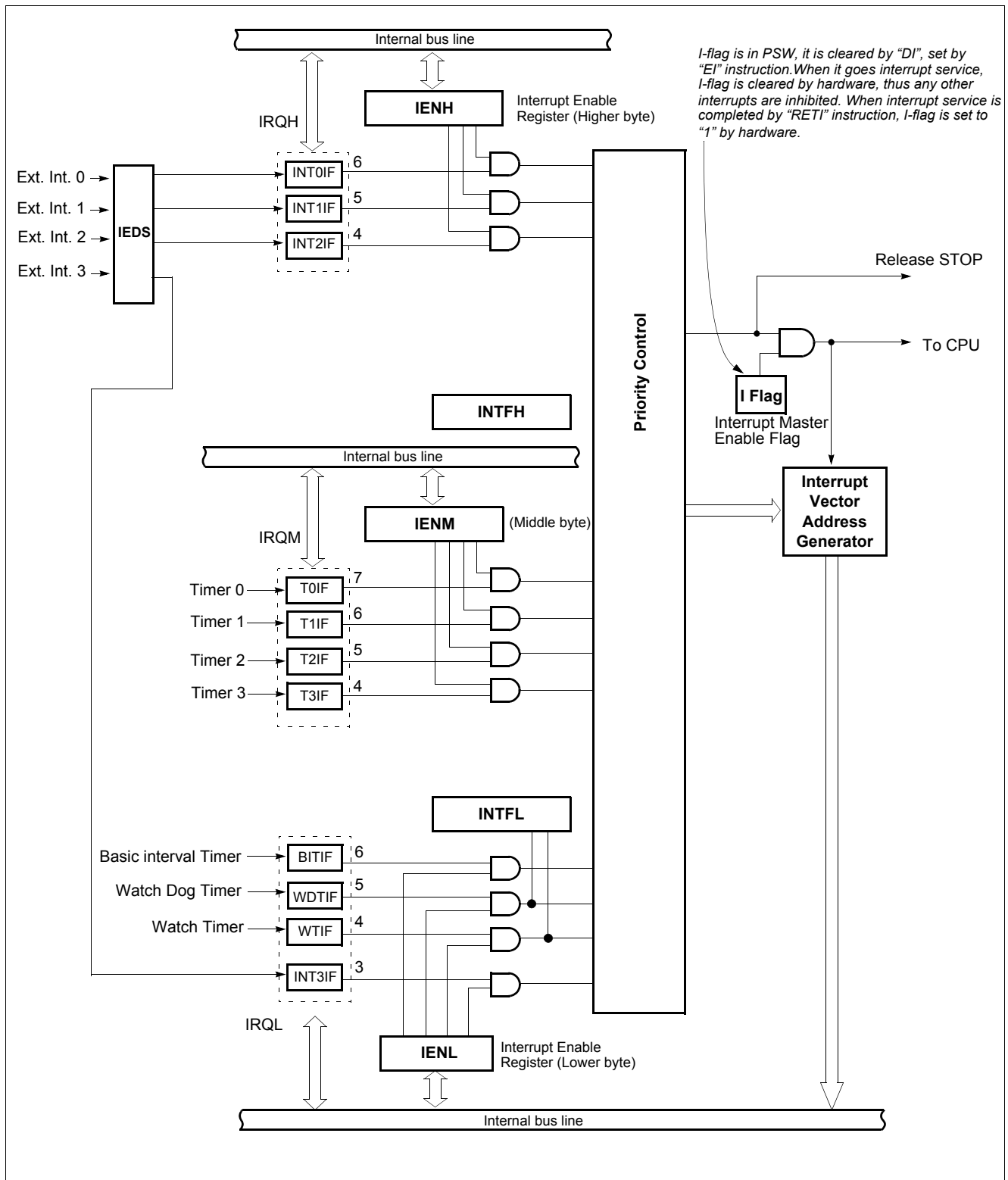

Figure 17-1 Block Diagram of Interrupt

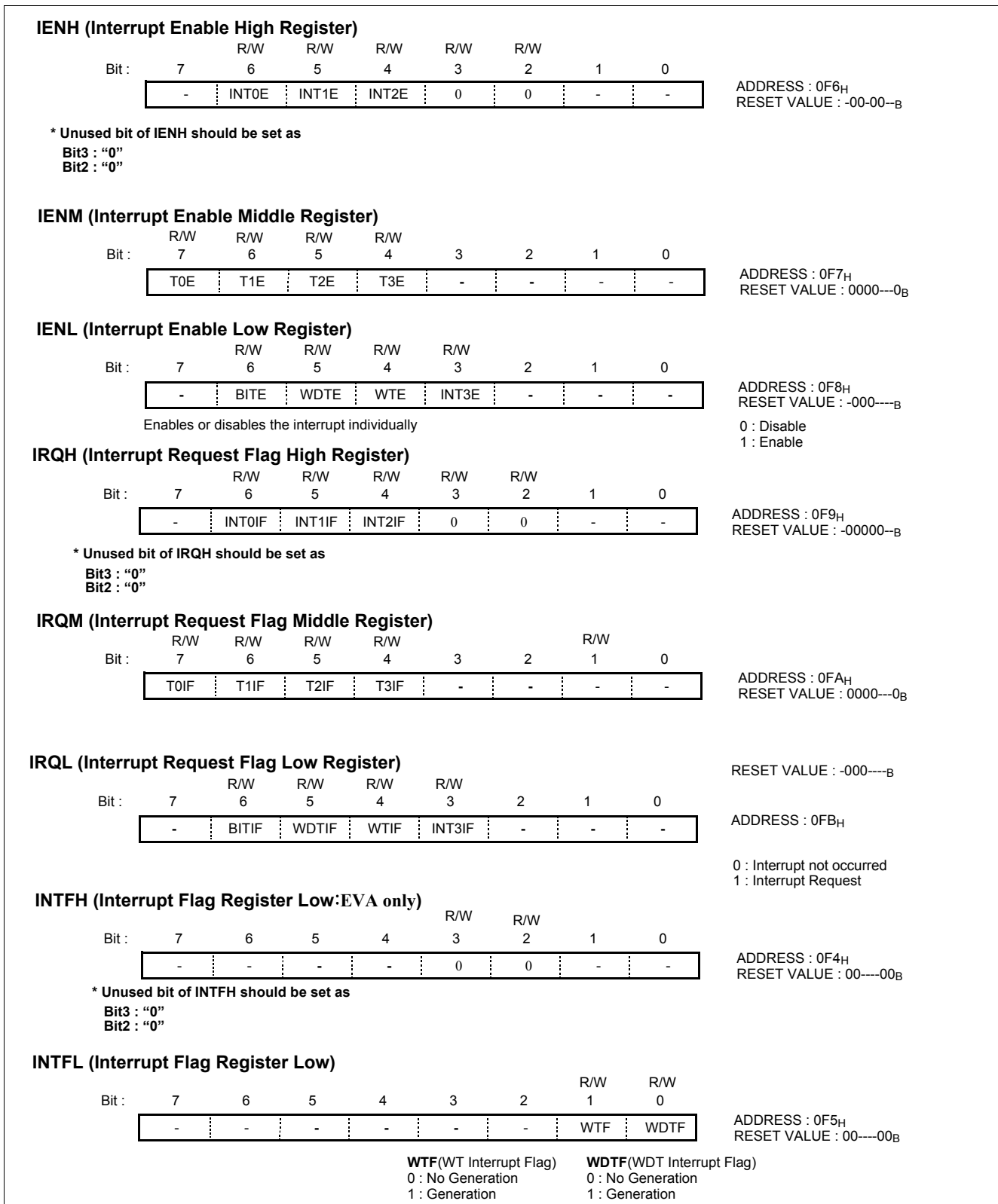

Figure 17-2 Interrupt Enable Registers and Interrupt Request Registers

17.1 Interrupt Sequence

An interrupt request is held until the interrupt is accepted or the interrupt latch is cleared to “0” by a reset or an instruction. Interrupt acceptance sequence requires $8 f_{OSC}$ ($2 \mu s$ at $f_{MAIN}=4MHz$) after the completion of the current instruction execution. The interrupt service task is terminated upon execution of an interrupt return instruction [RETI].

Interrupt acceptance

1. The interrupt master enable flag (I-flag) is cleared to “0” to temporarily disable the acceptance of any following maskable interrupts. When a non-maskable interrupt is accepted, the acceptance of any following interrupts is temporarily disabled.

2. Interrupt request flag for the interrupt source accepted is cleared to “0”.
3. The contents of the program counter (return address) and the program status word are saved (pushed) onto the stack area. The stack pointer decreases 3 times.
4. The entry address of the interrupt service program is read from the vector table address and the entry address is loaded to the program counter.
5. The instruction stored at the entry address of the interrupt service program is executed.

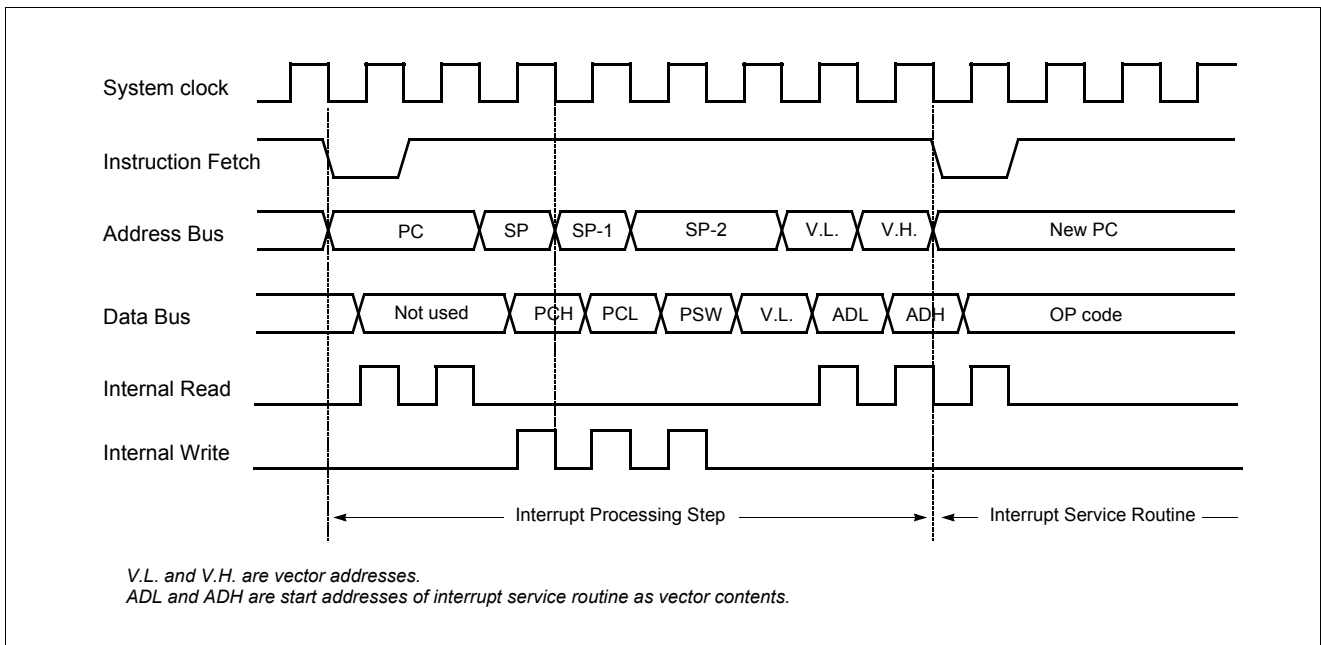
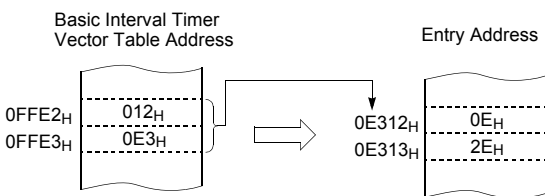

Figure 17-3 Timing chart of Interrupt Acceptance and Interrupt Return Instruction



Correspondence between vector table address for BIT interrupt and the entry address of the interrupt service program.

An interrupt request is not accepted until the I-flag is set to “1” even if a requested interrupt has higher priority than that of the current interrupt being serviced.

When nested interrupt service is required, the I-flag should be set to “1” by “EI” instruction in the interrupt service program. In this case, acceptable interrupt sources are selectively enabled by the individual interrupt enable flags.

Saving/Restoring General-purpose Register

During interrupt acceptance processing, the program counter and the program status word are automatically saved on the stack, but accumulator and other registers are not saved itself. If necessary, these registers should be saved by the software. Also, when multiple interrupt services are nested, it is necessary to avoid using the same data memory area for saving registers.

The following method is used to save/restore the general-purpose registers.

Example: Register saving

```
INTxx:  PUSH   A      ;SAVE ACC.
        PUSH   X      ;SAVE X REG.
        PUSH   Y      ;SAVE Y REG.
        [interrupt processing]
        POP    Y      ;RESTORE Y REG.
        POP    X      ;RESTORE X REG.
        POP    A      ;RESTORE ACC.
        RETI          ;RETURN
```

General-purpose registers are saved or restored by using push and pop instructions.

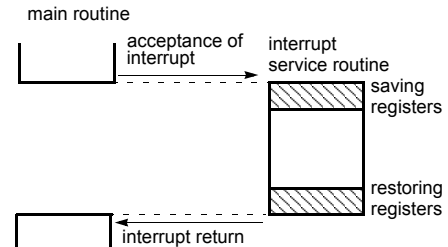

17.2 BRK Interrupt

Software interrupt can be invoked by BRK instruction, which has the lowest priority order.

Interrupt vector address of BRK is shared with the vector of TCALL 0 (Refer to Program Memory Section). When BRK interrupt is generated, B-flag of PSW is set to distinguish BRK from TCALL 0.

Each processing step is determined by B-flag as shown in Figure 17-4.

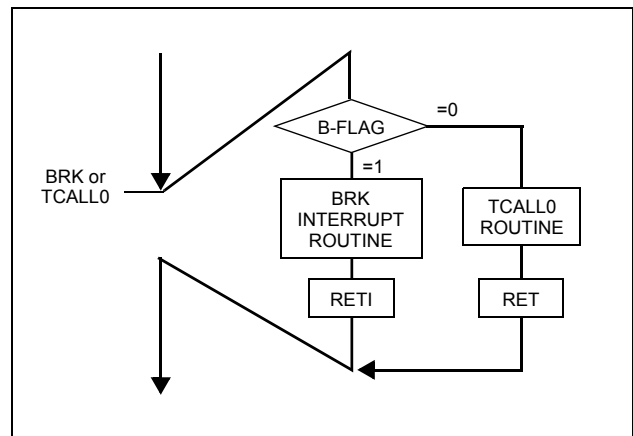

Figure 17-4 Execution of BRK/TCALL0

17.3 Multi Interrupt

If two requests of different priority levels are received simultaneously, the request of higher priority level is serviced. If requests of the interrupt are received at the same time simultaneously, an internal polling sequence determines by hardware which request is serviced.

However, multiple processing through software for special features is possible. Generally when an interrupt is accepted, the I-flag is cleared to disable any further interrupt. But as user sets I-flag in interrupt routine, some further interrupt can be serviced even if certain interrupt is in progress.

Example: Even though Timer1 interrupt is in progress, INTO interrupt serviced without any suspend.

```
TIMER1:  PUSH   A
         PUSH   X
         PUSH   Y
```

```
LDM     IENH, #40H   ; Enable INTO only
LDM     IENM, #0     ; Disable other
LDM     IENL, #0     ; Disable other
EI      ; Enable Interrupt
:
:
:
LDM     IENH, #0FFH  ; Enable all interrupts
LDM     IENM, #0FFH
LDM     IENL, #0F0H
POP     Y
POP     X
POP     A
RETI
```

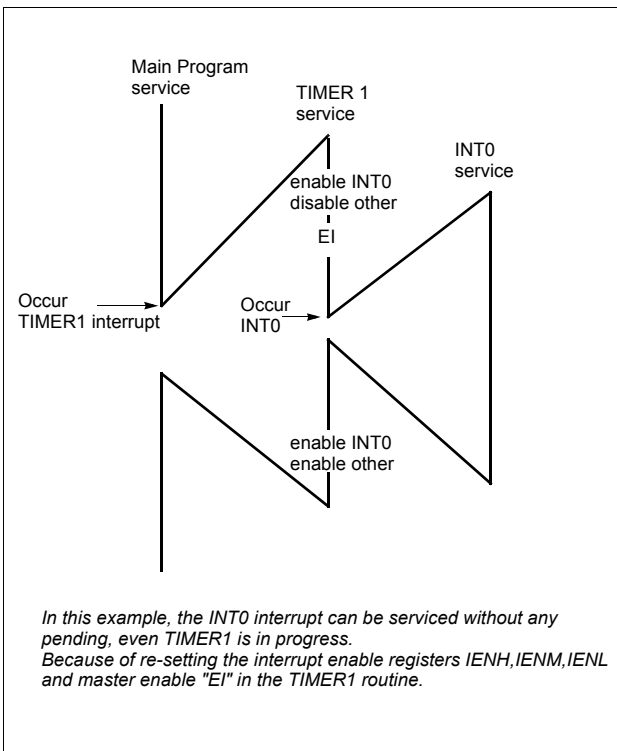

Figure 17-5 Execution of Multi Interrupt

17.4 External Interrupt

The external interrupt on INT0, INT1, INT2 and INT3 pins are edge triggered depending on the edge selection register IEDS (address 0FC_H) as shown in Figure 17-6.

The edge detection of external interrupt has three transition activated mode: rising edge, falling edge, and both edge.

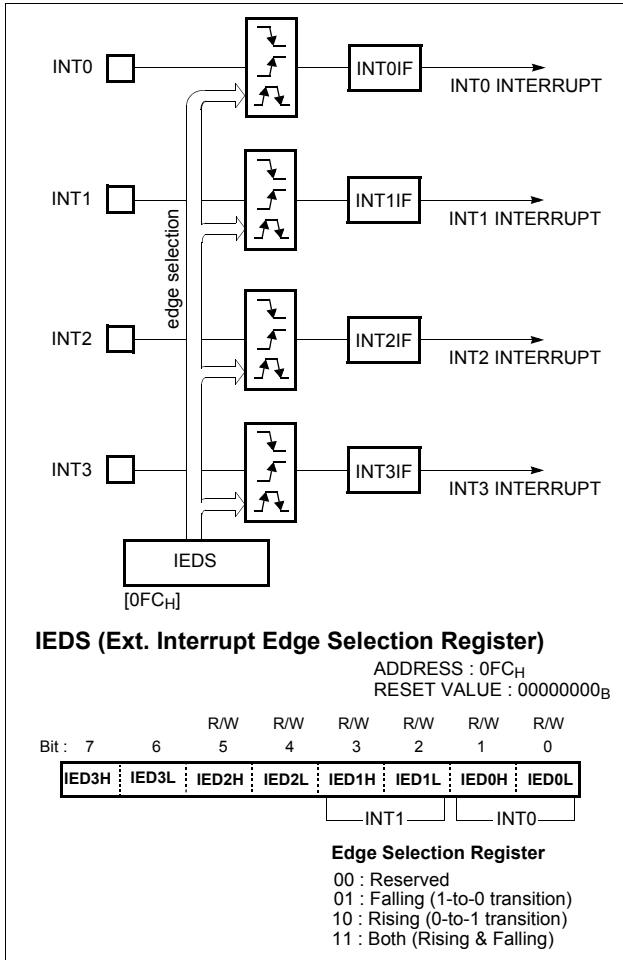

Figure 17-6 External Interrupt Block Diagram

Example: To use as an INT0

```

:
:
;**** Set port as an input port R0
LDM R0IO,#1011_1111B
;
;**** Set port as an interrupt port
LDM PSR0,#0100_0000B
;
;**** Set Falling-edge Detection
LDM IEDS,#0000_0001B
:
:
:

```

Response Time

The INT0, INT1, INT2 and INT3 edge are latched into INT0F, INT1F, INT2F and INT3F at every machine cycle. The values are not actually polled by the circuitry until the next machine cycle. If a request is active and conditions are right for it to be acknowledged, a hardware subroutine call to the requested service routine will be the next instruction to be executed. The DIV itself takes twelve cycles. Thus, a maximum of twelve complete machine cycles elapse between activation of an external interrupt request and the beginning of execution of the first instruction of the service routine.

Interrupt response timings are shown in Figure 17-7.

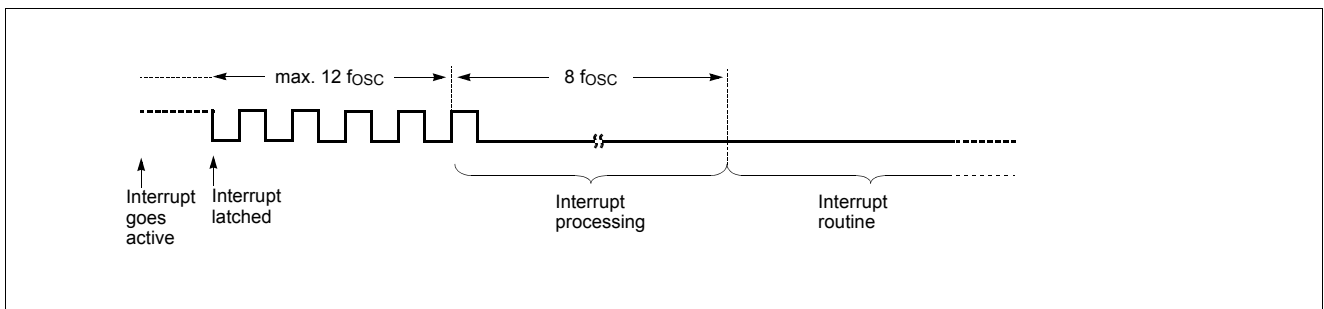

Figure 17-7 Interrupt Response Timing Diagram

18. LCD DRIVER

The MC80F7708A has the circuit that directly drives the liquid crystal display (LCD) and its control circuit. The segment/common driver directly drives the LCD panel, and the LCD controller generates the segment/common signals according to the RAM which stores display data. VCL3 ~ VCL0 voltage are made by the internal bias resistor circuit.

The MC80F7708A has the segment output port 20 pins (SEG0 ~ SEG19) and Common output port 4 pins (COM0 ~ COM3).

The Figure 18-1 shows the configuration of the LCD driver.

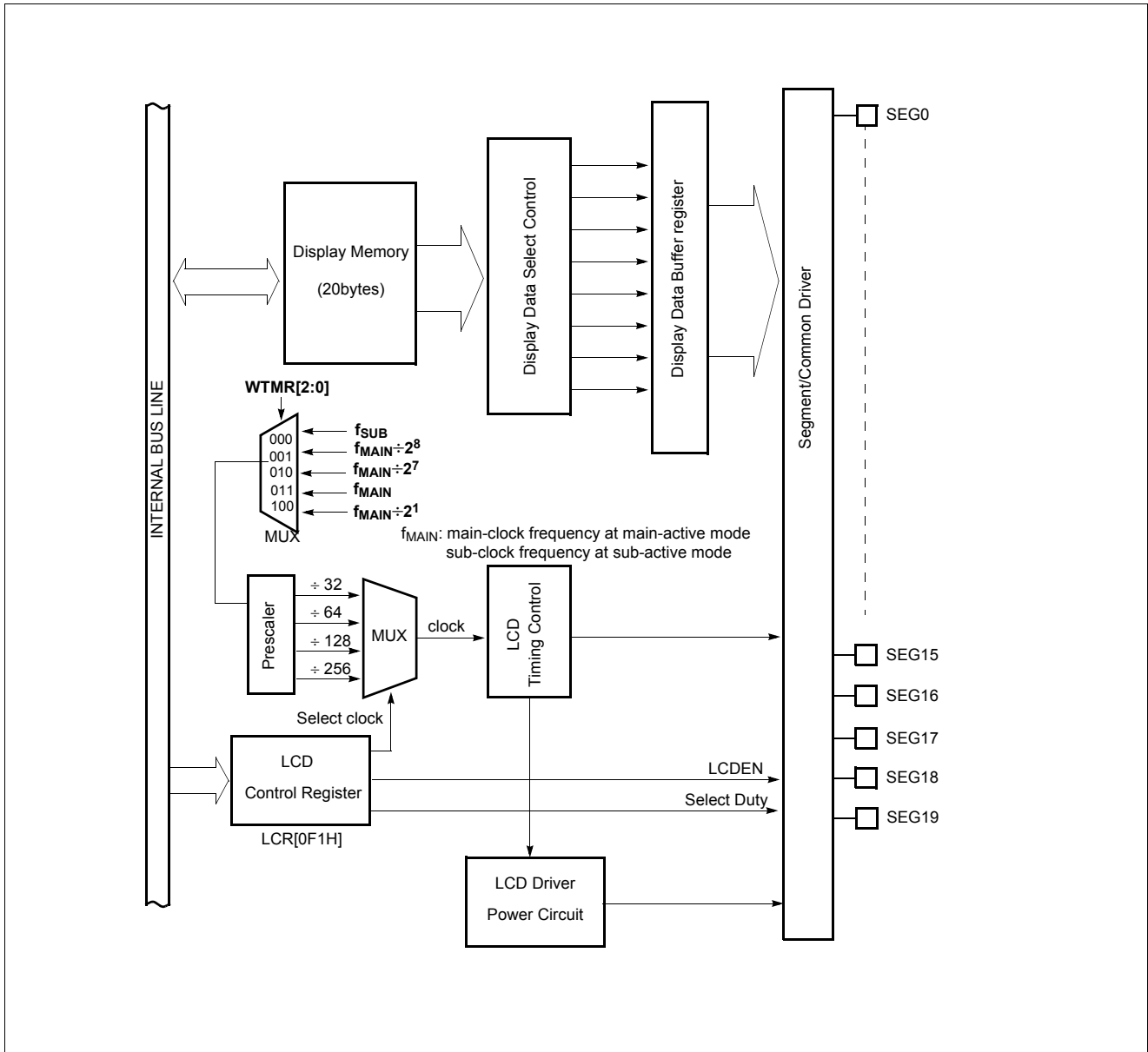

Figure 18-1 LCD Driver Block Diagram

18.1 Control of LCD Driver Circuit

The LCD driver is controlled by the LCD Control Register (LCR). The LCR[1:0] determines the frequency of COM signal scanning of each segment output. RESET clears the LCD control register LCR values to logic zero. The LCD SEG or COM ports are selected by setting corresponding

bits of R5PSR, R6PSR or R7PSR to “0”.

The LCD display can continue to operate during SLEEP and STOP modes if sub-frequency clock is used as LCD clock source.

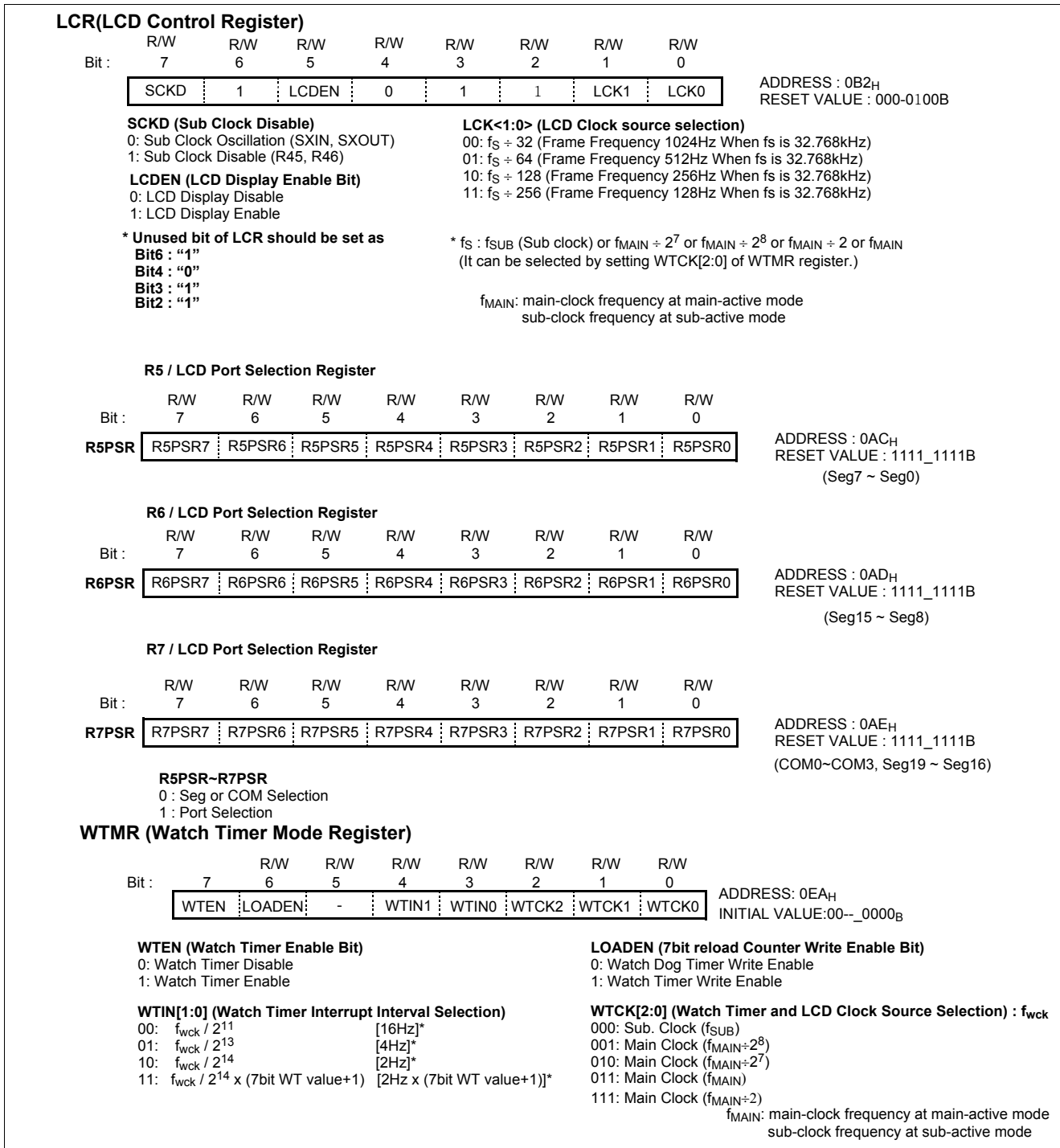

Figure 18-2 LCD Control Register

Note: If the SCKD is set to "1", the SXIN and SXOUT pin is used as normal I/O pin R45, R46.

Note: When the Sub clock is used as internal bias source clock, stabilization time is needed. Normally, the stabilization time is need more than 500ms.

Note: When selecting Sub clock as the LCD clock source, the WTCK[2:0] bit of WTMR(Watch Timer Mode Register) should be set to "000" as well as SCKD bit of LCR be set to "0".

Note: Bit 6, Bit 4, Bit 3 Bit 2 of LCR should be set to "1", "0", "1", "1" respectively.

Selecting Frame Frequency

Frame frequency is set to the base frequency as shown in the following Table 18-1. The f_S is selected to f_{SUB} (sub clock) which is 32.768kHz.

LCR[1:0]	LCD clock	Frame Frequency (Hz)	
		Duty = 1/4	Duty = 1/8(EVA only)
00	$f_{SUB} \div 32$	128	64
01	$f_{SUB} \div 64$	64	32
10	$f_{SUB} \div 128$	32	16
11	$f_{SUB} \div 256$	16	8

Table 18-1 Setting of LCD Frame Frequency

The matters to be attended to use LCD driver

In reset state, LCD source clock is sub clock. So, when the power is supplied, the LCD display would be flickered be-

fore the oscillation of sub clock is stabilized. It is recommended to use LCD display on after the stabilization time of sub clock is considered enough.

18.2 LCD BIAS Control

The MC80F7708A has internal Bias Circuit for driving LCD panel. It also has the contrast controller of 16 step.

The LCD Bias control register and internal Bias circuit is as shown in the Figure 18-3.

The SYS_SVLD[1:0] and SVLDF of LBCR register is used for controlling SVLD.

Note: The self bias check reference can be applied to contrast adjustment with VDD voltage variation. Because the VDD voltage can be calculated by reading the ADC value of self bias check reference. Writing appropriate value to CTR[3:0] with VDD level, LCD contrast variation with VDD can be reduced.

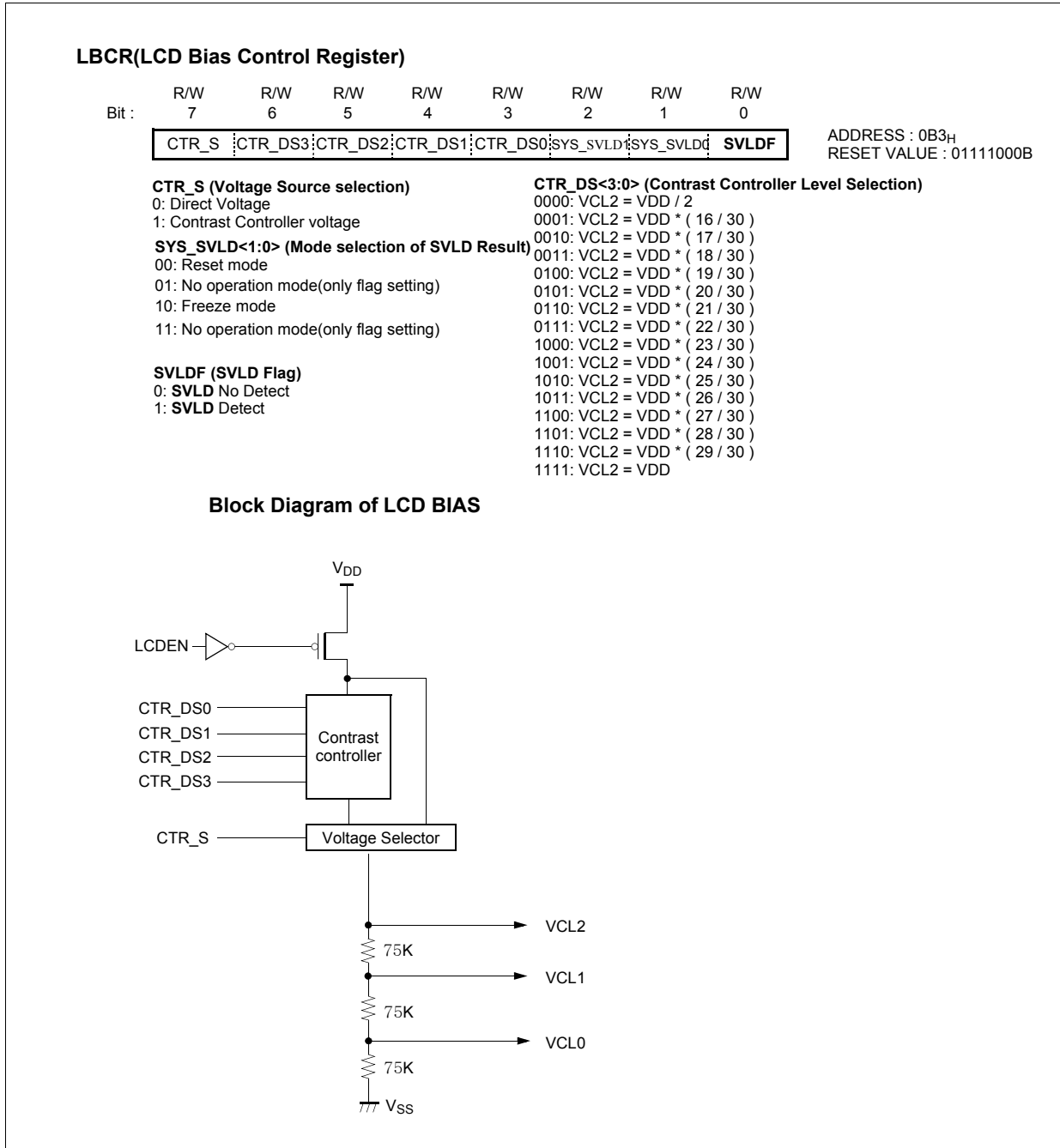

Figure 18-3 LCD Bias Control

18.3 LCD Display Memory

Display data are stored to the display data area (page 4) in the data memory.

The display data which stored to the display data area (address 0460_H-0473_H) are read automatically and sent to the LCD driver by the hardware. The LCD driver generates the segment signals and common signals in accordance with the display data and drive method. Therefore, display patterns can be changed by only overwriting the contents of the display data area with a program. The table look up instruction is mainly used for this overwriting.

Figure 18-4 shows the correspondence between the display data area and the SEG/COM pins. The LCD lights when the display data is “1” and turn off when “0”.

The SEG data for display is controlled by RPR (RAM Paging Register).

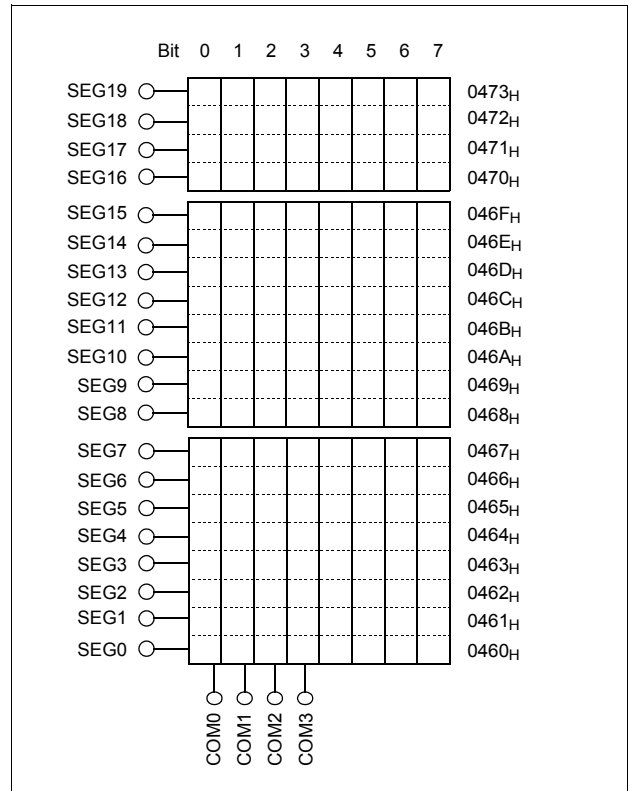

Figure 18-4 LCD Display Memory

18.4 Control Method of LCD Driver

Initial Setting

Flow chart of initial setting is shown in Figure 18-5.

Example: Driving of LCD

```

Select Frame Frequency      LDM   LCR,#4DH      ;fF=64Hz, 1/4 duty(fSUB= 32.768kHz)
:
Clear LCD Display Memory  C_LCD1: LDX   #60H
                          LDA   #0 ;RAM Clear
                          ; (0460H->0473H)
                          STA   {X}+
                          CMPX  #074H
                          BNE   C_LCD1
                          CLRG
:
Turn on LCD                SET1   LCR.5;Enable display
:
    
```

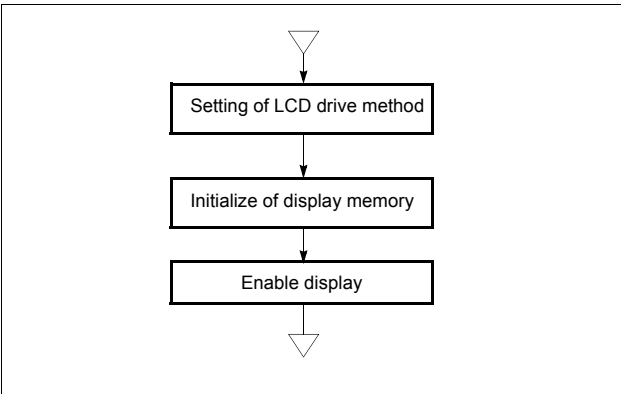

Figure 18-5 Initial Setting of LCD Driver

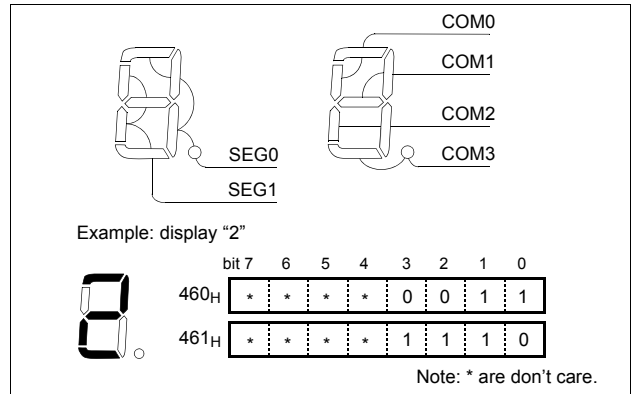

Figure 18-6 Example of Connection COM & SEG

Display Data

Normally, display data are kept permanently in the program memory and then stored at the display data area by the table look-up instruction. This can be explained using character display with 1/4 duty LCD as an example as well as any LCD panel. The COM and SEG connections to the LCD and display data are the same as those shown in Figure 18-6. Following is showing the programming example for displaying character.

Note: When power on RESET, sub oscillation start up time is required. Enable LCD display after sub oscillation is stabilized, or LCD may occur flicker at power on time shortly.

```

:
: CLRG
: LDX#<DISPRAM;Address included the data
: ;to be displayed.
GOLCD: LDA{X}
: TAY
: LDA!FONT+Y ;LOAD FONT DATA
: LDMRPR,#4;Set RPR = 4 to access LCD
: SETG ;Set Page 4
: LDX#60H
: STA{X}+;LOWER 4 BITS OF ACC. seg0
: XCN
: STA{X} ;UPPER 4 BITS OF ACC. seg1
: CLRG ;Set Page = 0
:
:
:
FONT DB 1101_0111B; "0"
DB 0000_0110B; "1"
DB 1110_0011B; "2"
DB 1010_0111B; "3"
DB 0011_0110B; "4"
DB 1011_0101B; "5"
DB 1111_0101B; "6"
DB 0000_0111B; "7"
DB 1111_0111B; "8"
DB 0011_0111B; "9"
    
```

LCD Waveform

The LCD duty(1/4) can be selected by LCR register. The example of 1/4 duty, 1/3 bias are shown in shown Fig- ure 18-7.

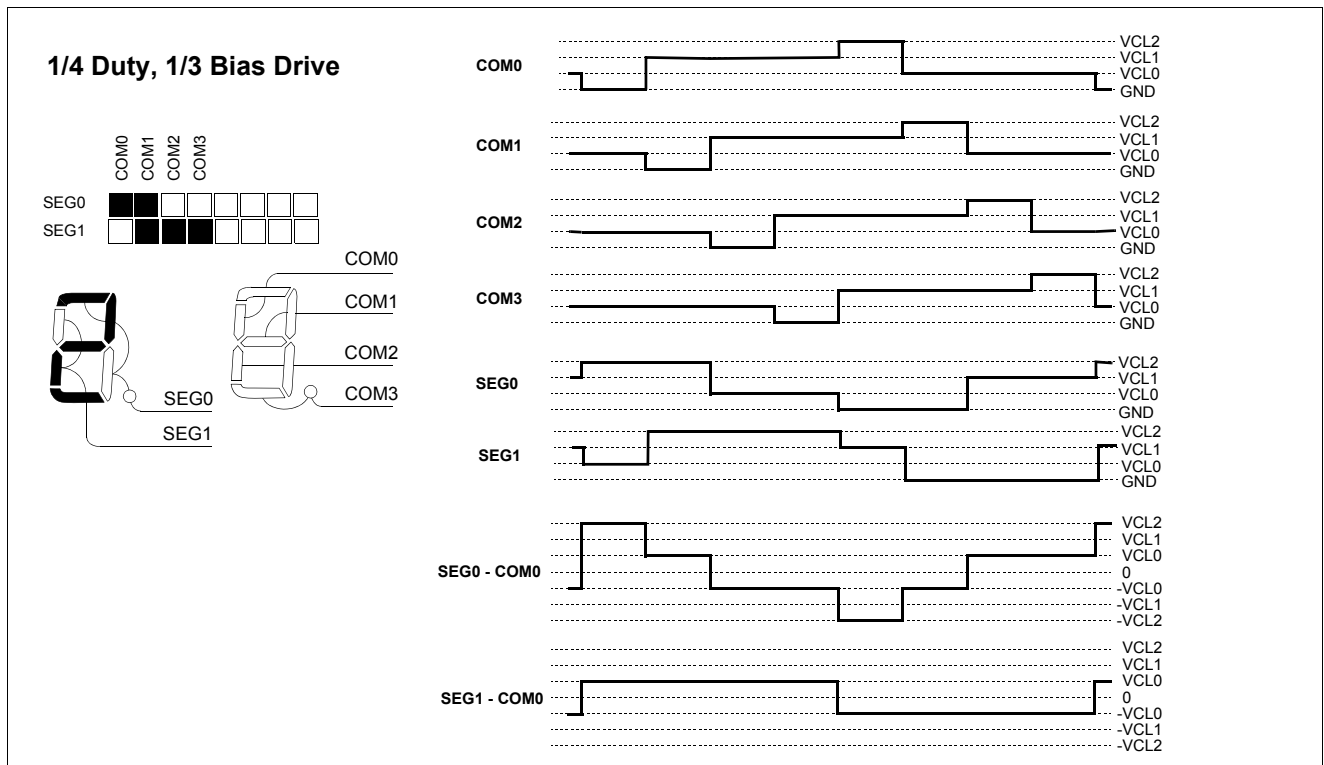

Figure 18-7 Example of LCD drive output

18.5 Duty and Bias Selection of LCD Driver

4 kinds of driving methods can be selected by LCDD[1:0] (bits 3 and 2 of LCD control register) and connection of BIAS pin exter-

nally. Figure 18-8 shows typical driving waveforms for LCD.).

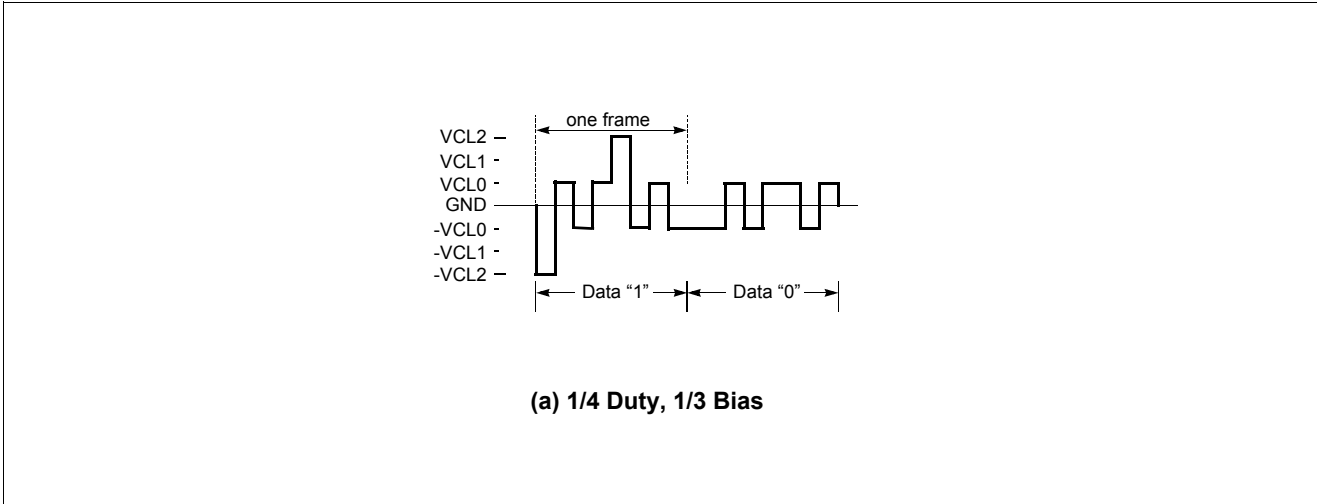

Figure 18-8 LCD Drive Waveform (Voltage COM-SEG Pins)

19. OPERATION MODE

The system clock controller starts or stops the main frequency clock oscillator, which is controlled by system clock mode register (SCMR). Figure 19-1 shows the operating mode transition diagram.

System clock control is performed by the system clock mode register (SCMR). During reset, this register is initialized to “0” so that the main-clock operating mode is selected.

Main Active mode

This mode is fast-frequency operating mode. The CPU and

the peripheral hardware are operated on the high-frequency clock. At reset release, this mode is invoked.

SLEEP mode

In this mode, the CPU clock stops while peripherals and the oscillation source continue to operate normally.

STOP mode

In this mode, the system operations are all stopped, holding the internal states valid immediately before the stop at the low power consumption level.

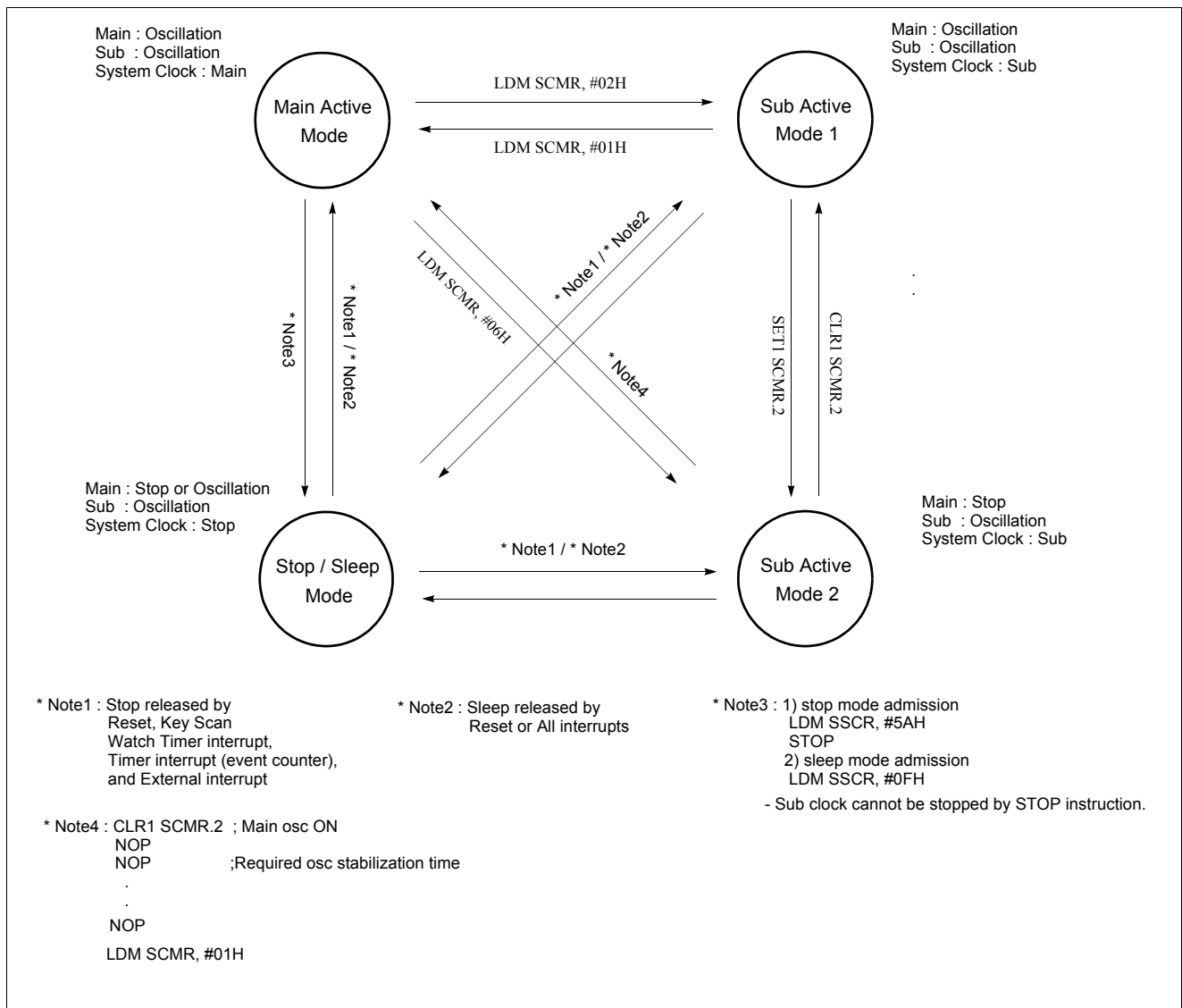

Figure 19-1 Operating Mode

19.1 Operation Mode Switching

Shifting from the Normal operation to the SLEEP mode

By writing “0F_H” into SSCR which will be explained in "20.1 SLEEP Mode" on page 88, the CPU clock stops and the SLEEP mode is invoked. The CPU stops while other peripherals are operate normally.

The way of release from this mode is RESET and all available interrupts.

For more detail, See "20.1 SLEEP Mode" on page 88

Shifting from the Normal operation to the STOP mode

By writing “5A_H” into SSCR and then executing STOP instruction, the main-frequency clock oscillation stops and the STOP mode is invoked. But sub-frequency clock oscillation is operated continuously.

After the STOP operation is released by reset, the operation mode is changed to Main active mode.

The methods of release are RESET, Key scan interrupt, Watch Timer interrupt, Timer/Event counter1 (EC0 pin) and External Interrupt.

For more details, see "20.2 STOP Mode" on page 89.

Note: *In the STOP and SLEEP operating modes, the power consumption by the oscillator and the internal hardware is reduced. However, the power for the pin interface (depending on external circuitry and program) is not directly associated with the low-power consumption operation. This must be considered in system design as well as interface circuit design.*

20. POWER DOWN OPERATION

MC80F7708A have 2 power down mode. In power down mode, power consumption is reduced considerably in Battery operation that Battery life can be extended a lot.

Sleep mode is entered by writing “0FH” into Stop and Sleep Control Register(SSCR), and STOP mode is entered by writing “5AH” into SSCR and then executing STOP instruction.

20.1 SLEEP Mode

In this mode, the internal oscillation circuits remain active.

Oscillation continues and peripherals are operate normally but CPU stops. The status of all Peripherals in this mode is shown in Table 20-1. Sleep mode is entered by writing “0FH” into SSCR (address 0E9H).

It is released by RESET or all interrupt. To be released by interrupt, interrupt should be enabled before Sleep mode.

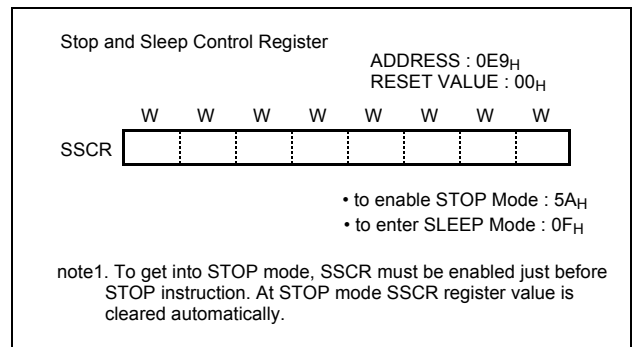

Figure 20-1 SLEEP Mode Register

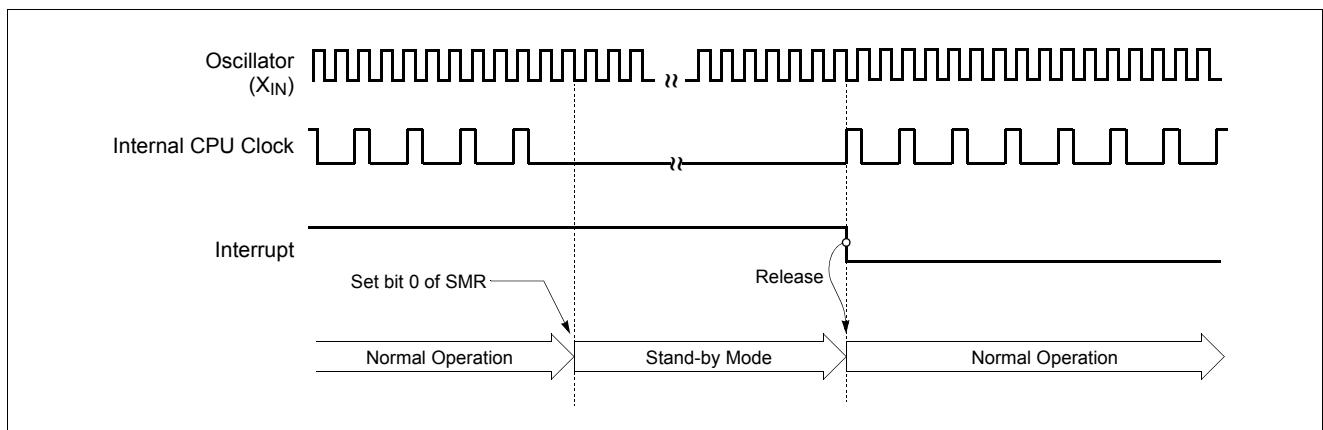

Figure 20-2 Sleep Mode Release Timing by External Interrupt

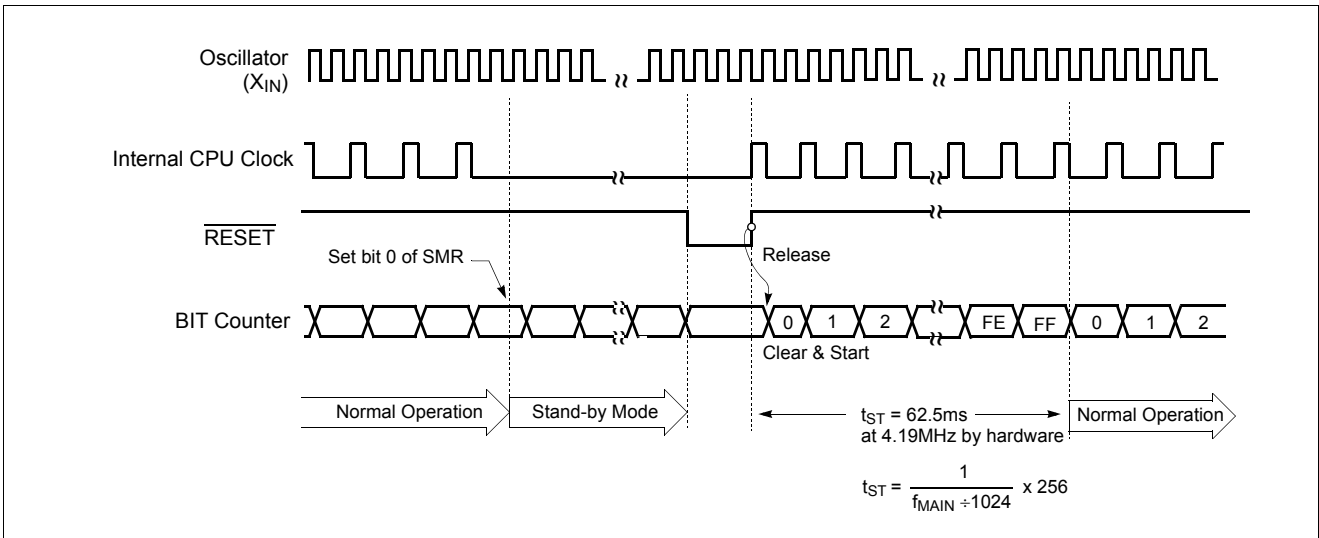

Figure 20-3 SLEEP Mode Release Timing by RESET pin

20.2 STOP Mode

For applications where power consumption is a critical factor, this device provides STOP mode for reducing power consumption.

Start The Stop Operation

The STOP mode can be entered by STOP instruction during program execution. In Stop mode, the on-chip main-

frequency oscillator, system clock, and peripheral clock are stopped (Watch timer clock is oscillating continuously). With the clock frozen, all functions are stopped, but the on-chip RAM and Control registers are held. The port pins output the values held by their respective port data register and the port direction registers. The status of peripherals during Stop mode is shown below.

Peripheral	STOP Mode	Sleep Mode
CPU	All CPU operations are disabled	All CPU operations are disabled
RAM	Retain	Retain
LCD driver	Operates continuously	Operates continuously
Basic Interval Timer	Halted	Operates continuously
Timer/Event counter 0	Halted (Only when the Event counter mode is enabled, Timer 0 operates normally)	Timer/Event counter 0 operates continuously
Watch Timer	Operates continuously	Operates continuously
Main-oscillation	Stop (X _{IN} =L, X _{OUT} =L)	Oscillation ¹
Sub-oscillation	Oscillation	Oscillation
I/O ports	Retain	Retain
Control Registers	Retain	Retain
Release method	by RESET, Watch Timer interrupt, Timer interrupt (EC0), and External interrupt	by RESET, All interrupts

Table 20-1 Peripheral Operation during Power Down Mode

1. Refer to the Table 10-2

Operating Clock source	Main Operating Mode	Main Sleep Mode	Sub Active Operating Mode	Sub Sleep Operating Mode	Stop Mode 1	Stop Mode 2
Main Clock	Oscillation	Oscillation	SCMR[2] 0 ==>Oscillation 1 ==>Stop	SCMR[2] 0 ==>Oscillation 1 ==>Stop	Stop	Stop
Sub Clock	Oscillation	Oscillation	Oscillation	Oscillation	Oscillation	Stop
System Clock	Active	Stop	Active	Stop	Stop	Stop
Peri. Clock	Active	Active	Active	Active	Stop ¹	Stop

1. Except watch timer(sub clock) and LCD driver(sub clock)

Table 20-2 Clock Operation of STOP and SLEEP mode

Note: Since the X_{IN} pin is connected internally to GND to avoid current leakage due to the crystal oscillator in STOP mode, do not use STOP instruction when an external clock is used as the main system clock.

In the Stop mode of operation, V_{DD} can be reduced to minimize power consumption. Be careful, however, that V_{DD} is not reduced before the Stop mode is invoked, and that V_{DD} is restored to its normal operating level before the Stop mode is terminated.

The reset should not be activated before V_{DD} is restored to its normal operating level, and must be held active long enough to allow the oscillator to restart and stabilize. And after STOP instruction, at least two or more NOP instruction should be written as shown in example below.

Example)

```

:
LDM    CKCLR, #0000_1111B
STOP
NOP
NOP
NOP
:
    
```

The Interval Timer Register CKCLR should be initialized by software in order that oscillation stabilization time should be longer than 20ms before STOP mode.

Release the STOP mode

The exit from STOP mode is using hardware reset or external interrupt, watch timer or timer interrupt (EC0).

To release STOP mode, corresponding interrupt should be enabled before STOP mode.

Specially as a clock source of Timer/Event counter, EC0 pin can release it by Timer/Event counter Interrupt request.

Reset redefines all the control registers but does not change the on-chip RAM. External interrupts allow both on-chip RAM and Control registers to retain their values.

Start-up is performed to acquire the time for stabilizing oscillation. During the start-up, the internal operations are all stopped.

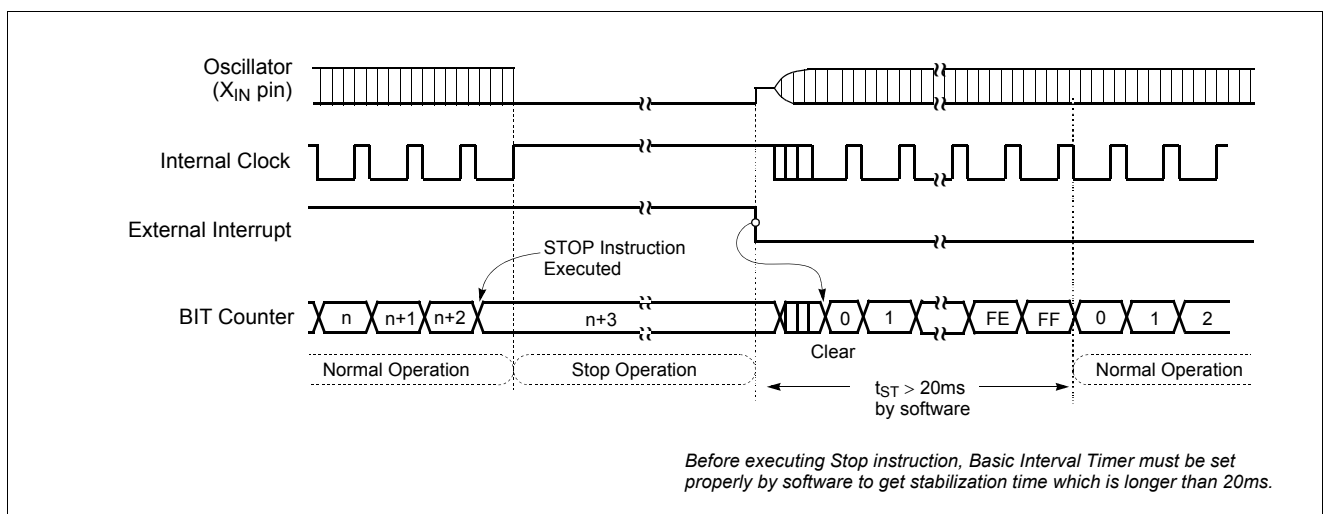

Figure 20-4 STOP Mode Release Timing by External Interrupt

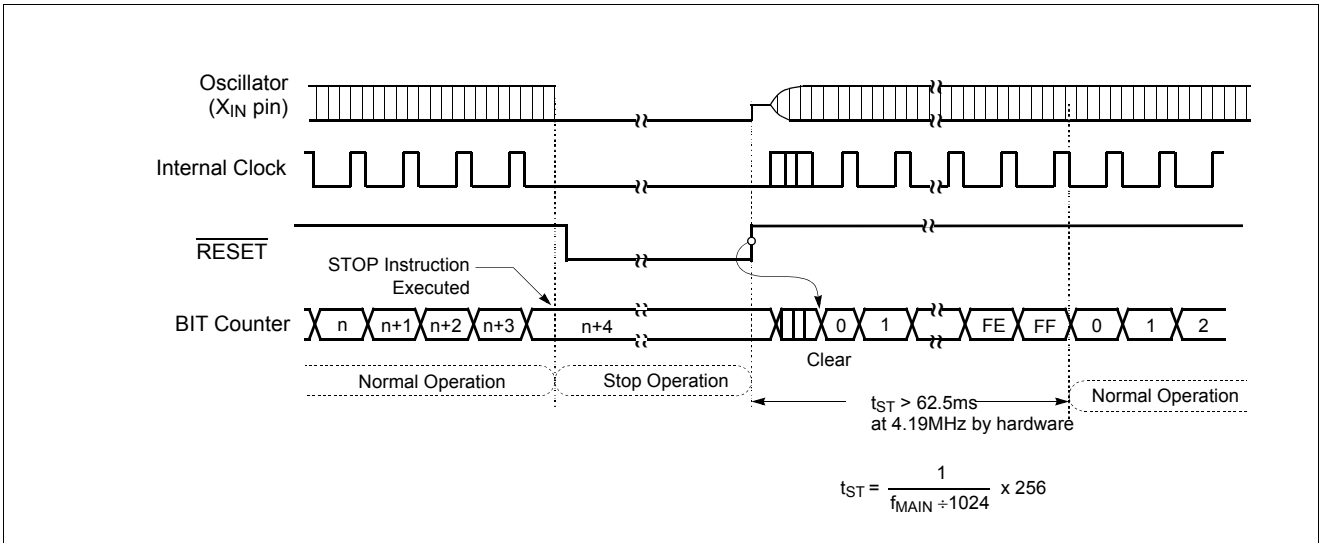

Figure 20-5 STOP Mode Release Timing by RESET

Minimizing Current Consumption

The Stop mode is designed to reduce power consumption. To minimize current drawn during Stop mode, the user should turn-off output drivers that are sourcing or sinking current, if it is practical.

Note: In the STOP operation, the power dissipation associated with the oscillator and the internal hardware is lowered; however, the power dissipation associated with the pin interface (depending on the external circuitry and program) is not directly determined by the hardware operation of the STOP feature. This point should be little current flows when the input level is stable at the power voltage level (V_{DD}/V_{SS}); however, when the input level becomes higher than the power voltage level (by approximately 0.3V), a current begins to flow. Therefore, if cutting off the output transistor at an I/O port puts the pin signal into the high-impedance state, a current flow across the ports input transistor, requiring it to fix the level by pull-up or other means.

It should be set properly that current flow through port doesn't exist.

First consider the setting to input mode. Be sure that there is no current flow after considering its relationship with external circuit. In input mode, the pin impedance viewing from external MCU is very high that the current doesn't flow.

But input voltage level should be V_{SS} or V_{DD} . Be careful that if unspecified voltage, i.e. if uniformed voltage level (not V_{SS} or V_{DD}) is applied to input pin, there can be little current (max. 1mA at around 2V) flow.

If it is not appropriate to set as an input mode, then set to output mode considering there is no current flow. Setting to High or Low is decided considering its relationship with external circuit. For example, if there is external pull-up resistor then it is set to output mode, i.e. to High, and if there is external pull-down resistor, it is set to low.

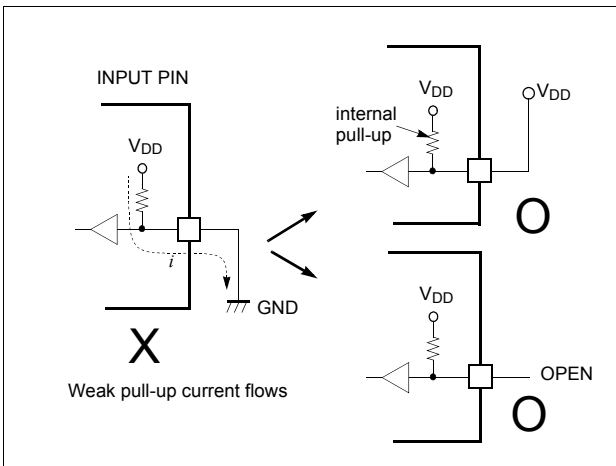
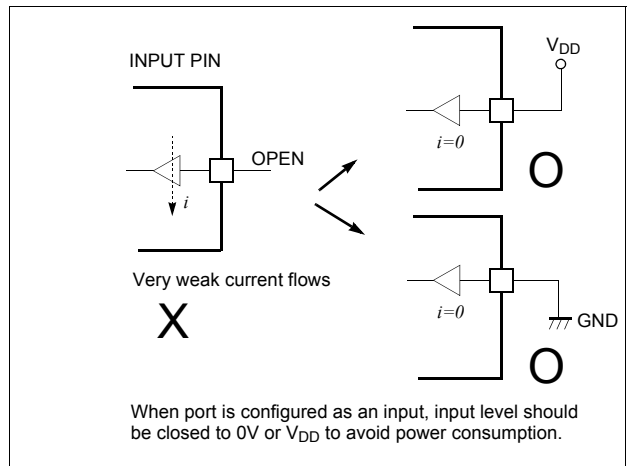

Figure 20-6 Application Example of Unused Input Port



When port is configured as an input, input level should be closed to 0V or V_{DD} to avoid power consumption.

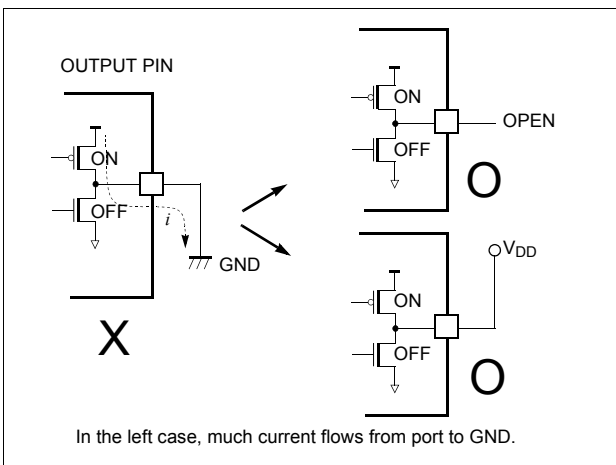
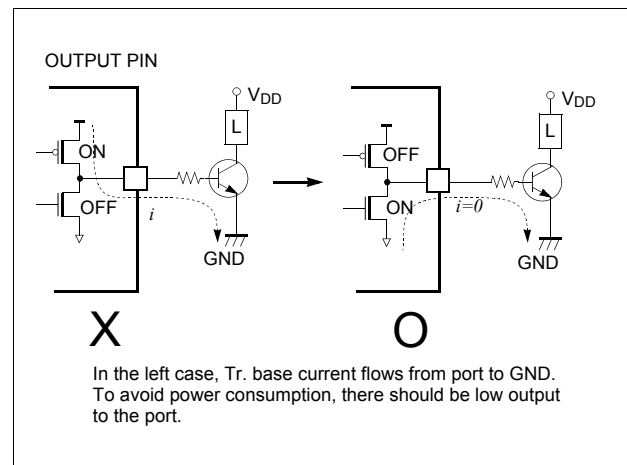

Figure 20-7 Application Example of Unused Output Port



In the left case, Tr. base current flows from port to GND. To avoid power consumption, there should be low output to the port.

21. OSCILLATOR CIRCUIT

The MC80F7708A have three oscillation circuits internally. X_{IN} and X_{OUT} are input and output for main frequency and SX_{IN} and SX_{OUT} are input and output for sub frequen-

cy, respectively, inverting amplifier which can be configured for being used as an on-chip oscillator, as shown in Figure 21-1.

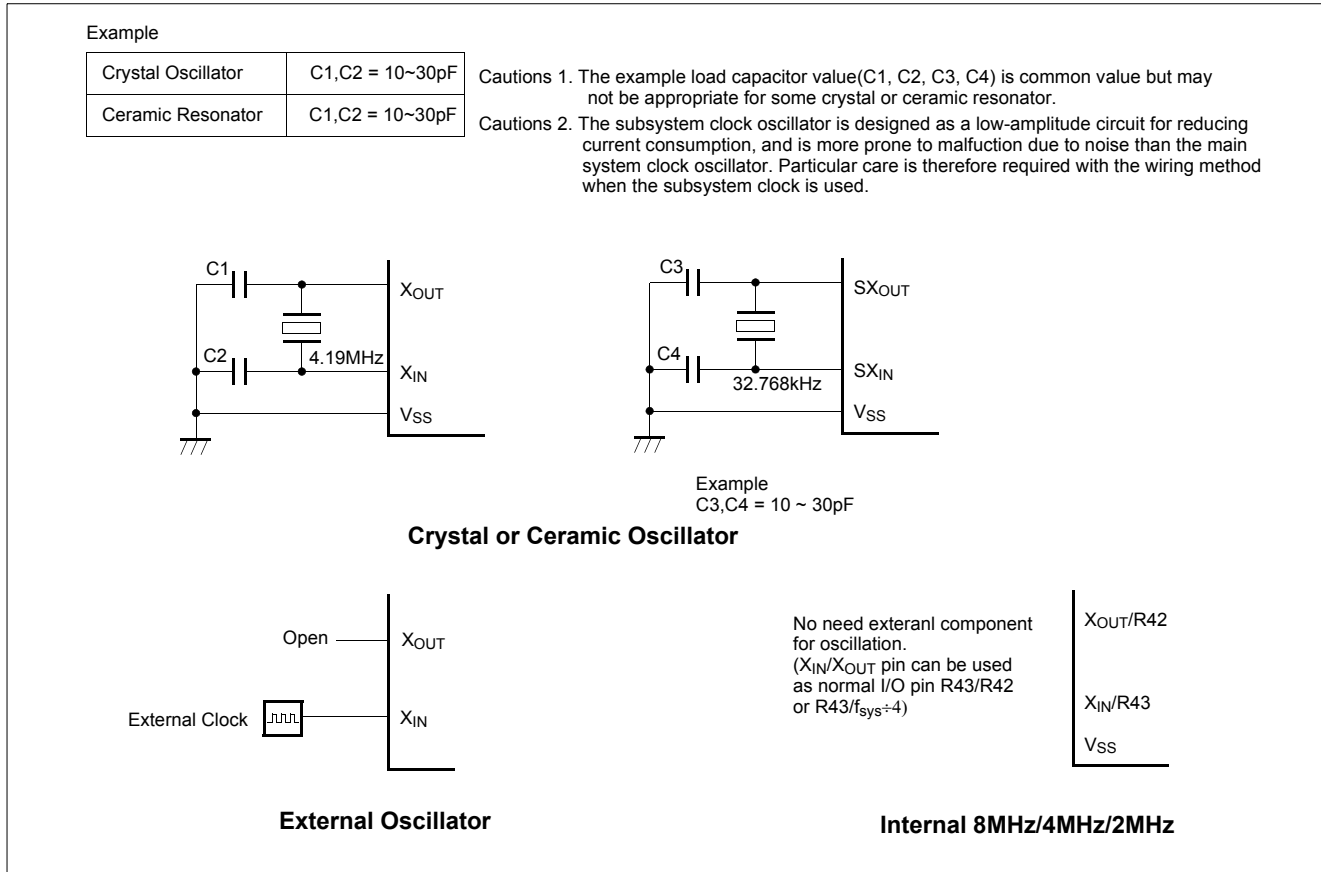

Figure 21-1 Oscillation Circuit

Oscillation circuit is designed to be used either with a ceramic resonator or crystal oscillator. Since each crystal and ceramic resonator have their own characteristics, the user should consult the crystal manufacturer for appropriate values of external components.

In addition, see Figure 21-2 for the layout of the crystal.

Note: Minimize the wiring length. Do not allow the wiring to intersect with other signal conductors. Do not allow the wiring to come near changing high current. Set the potential of the grounding position of the oscillator capacitor to that of V_{SS} . Do not ground it to any ground pattern where high current is present. Do not fetch signals from the oscillator.

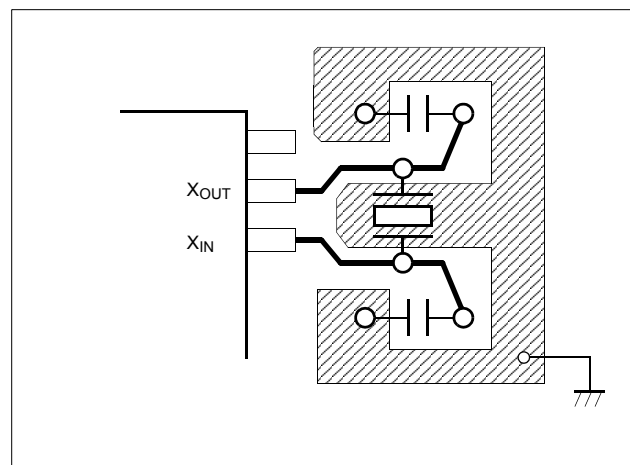

Figure 21-2 Layout of Oscillator PCB circuit

22. RESET

The MC80F7708A has four reset generation sources; external reset input, power on reset (POR), Supply Voltage level Detector Rest (SVLDR) and watch-dog timer reset.

Table 22-1 shows on-chip hardware initialization by reset action.

On-chip Hardware	Initial Value
Program counter (PC)	(FFFF _H) - (FFFE _H)
RAM page register (RPR)	0
G-flag (G)	0

On-chip Hardware	Initial Value
Operation mode	Main-frequency clock
Peripheral clock	On
Control registers	Refer to Table 8-1 on page 29

Table 22-1 Initializing Internal Status by Reset Action

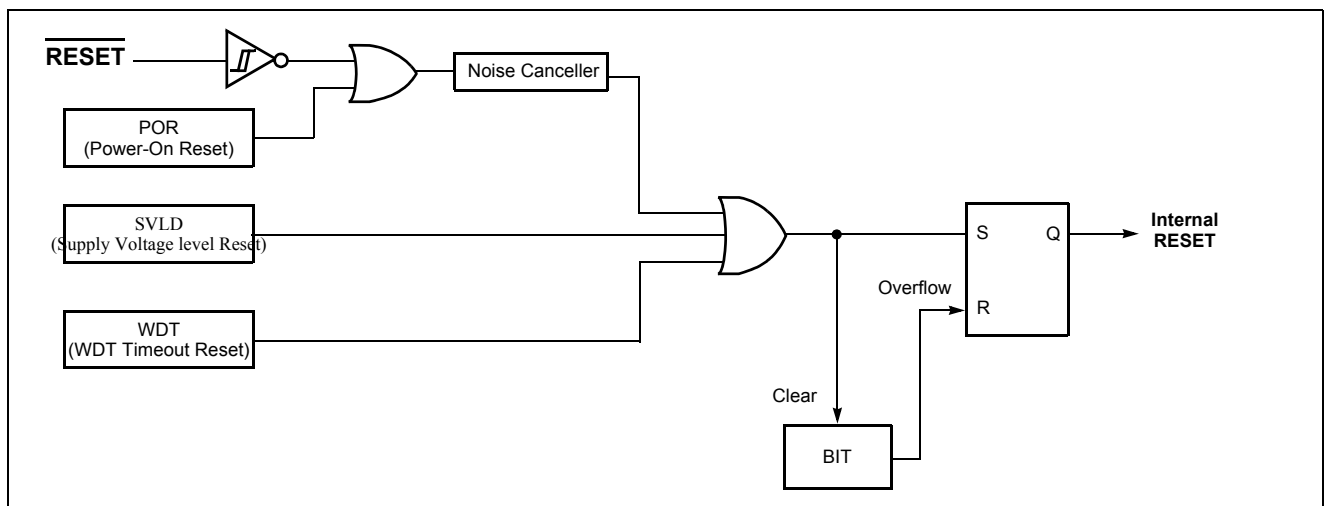

Figure 22-1 RESET Block Diagram

22.1 External Reset Input

The reset input is the $\overline{\text{RESET}}$ pin, which is the input to a Schmitt Trigger. A reset accomplished by holding the $\overline{\text{RESET}}$ pin to low for at least 8 oscillator periods, within the operating voltage range and oscillation stable, it is applied, and the internal state is initialized. After reset, 65.5ms (at 4MHz) and 7 oscillator periods are required to start execution as shown in Figure 22-3.

Internal User RAM is not affected by reset. When V_{DD} is turned on, the RAM content is indeterminate. Therefore, this RAM should be initialized before read or tested it.

When the $\overline{\text{RESET}}$ pin input goes to high, the reset operation is released and the program execution starts at the vector address stored at FFFE_H - FFFF_H.

A connection for normal power-on-reset is shown in Figure 22-2.

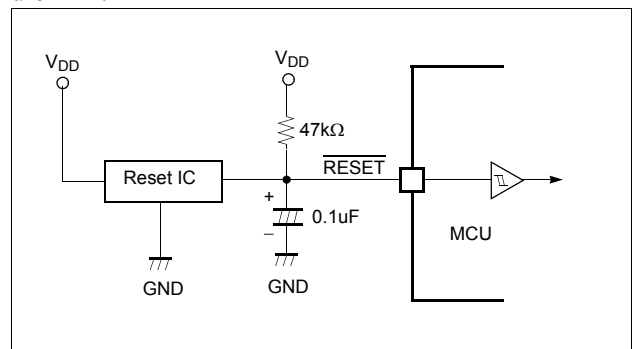

Figure 22-2 Normal Power-on-Reset Circuit

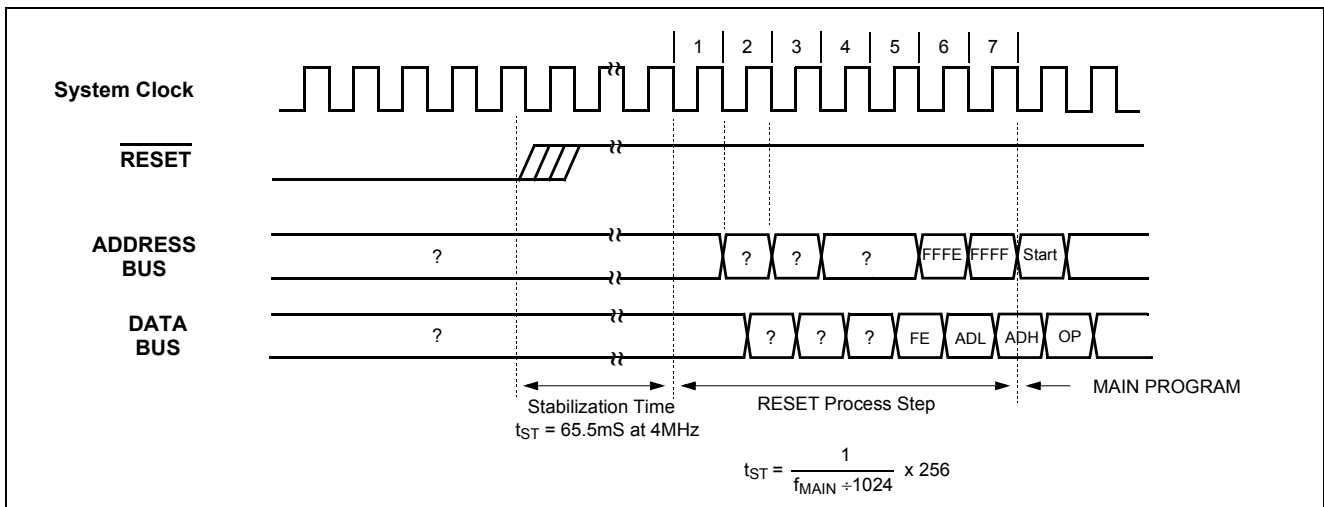

Figure 22-3 Timing Diagram of RESET

22.2 Power On Reset

The on-chip POR circuit holds down the device in RESET until V_{DD} has reached a high enough level for proper operation. It will eliminate external components such as reset IC or external resistor and capacitor for external reset circuit. In addition that the \overline{RESET} pin can be used to normal input port R47 by setting “POR” and “R47EN” bit of the Configuration option area(20C7H) in Flash programming. When the device starts normal operation, its operating

parameters (voltage, frequency, temperature...etc) must be met.

Note: When “POR” option is checked and “R47EN” option is not checked, $\overline{RESET}/R47$ pin acts as external Reset input pin. In this case, the external reset circuit should be connected to \overline{RESET} pin. If external reset is not needed, not only “POR”, but also “R47EN” option should be checked.

22.3 SVLD Reset

Refer to “23. Supply Voltage Level Detector (SVLD)”

22.4 Watchdog Timer Reset

Refer to “14. WATCH DOG TIMER”

23. Supply Voltage Level Detector (SVLD)

The MC80F7708A has an on-chip SVLD(Supply Voltage Level Detector) circuitry to immunize against power noise. The SVLD control register SVLDR can enable or disable

the built in reset circuitry. The Block diagram of SVLD is shown in the Figure 23-1.

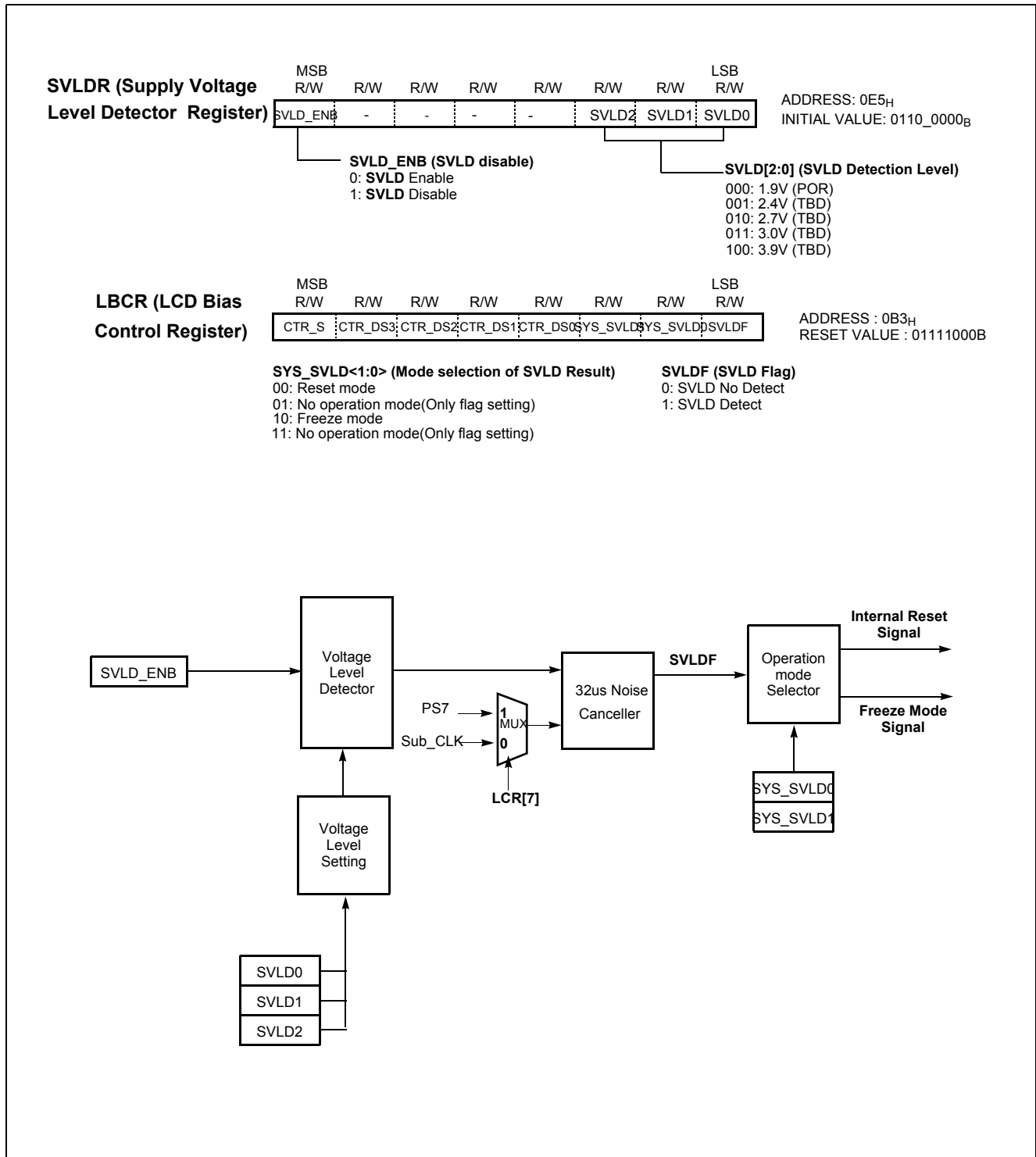

Figure 23-1 Block Diagram of SVLD (Built-In Reset)

The SVLD of MC80F7708A has 4 detection level which can be selected by SVLD[2:0].

SVLD does not generate internal reset signal or freeze mode signal because the 32us noise canceller eliminates low level detection signal less than 32us.

SVLD result can be selected by SYS_SVLD[1:0] of LBCR register. When SYS_SVLD[1:0] is set to "00", BIR generates reset signal. If SYS_SVLD[1:0] is set to "10", it generates freeze mode signal and CPU freeze until the VDD voltage returns to regular level.

SVLDF is set to "1" when SVLD occurs. It can be used to distinguish reset caused by SVLD and other.

When the POR is used, the SVL detection level should be set to the level less than POR level. If the POR level is 1.9V, SVL level 2.4V, 2.7V, 3.0V and 3.9V can not operate.

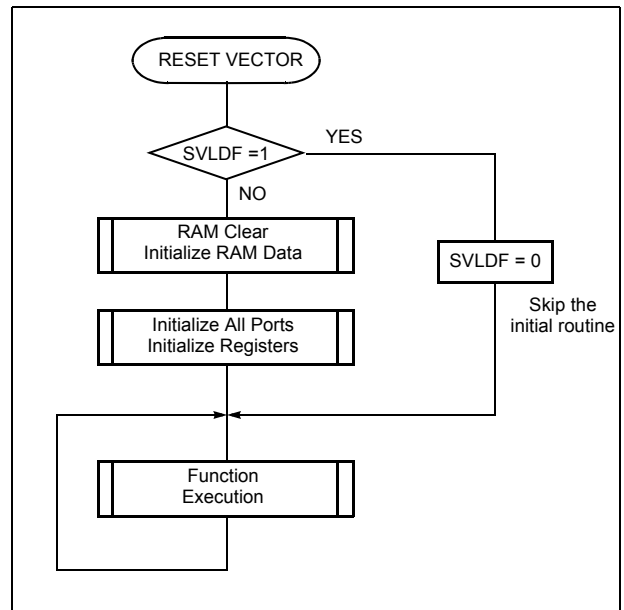

Figure 23-2 Example Flow of Reset flow by SVLD

24. Oscillation Noise Protector

The Oscillation Noise Protector (ONP) is used to supply stable internal system clock by excluding the noise which could be entered into oscillator and recovery the oscillation fail. This function could be enabled or disabled by the “ONP” bit of the Device configuration area (20C7H) for

the MC80F7708A.

The ONP function is like below.

- Recovery the oscillation wave crushed or loss caused by high frequency noise.

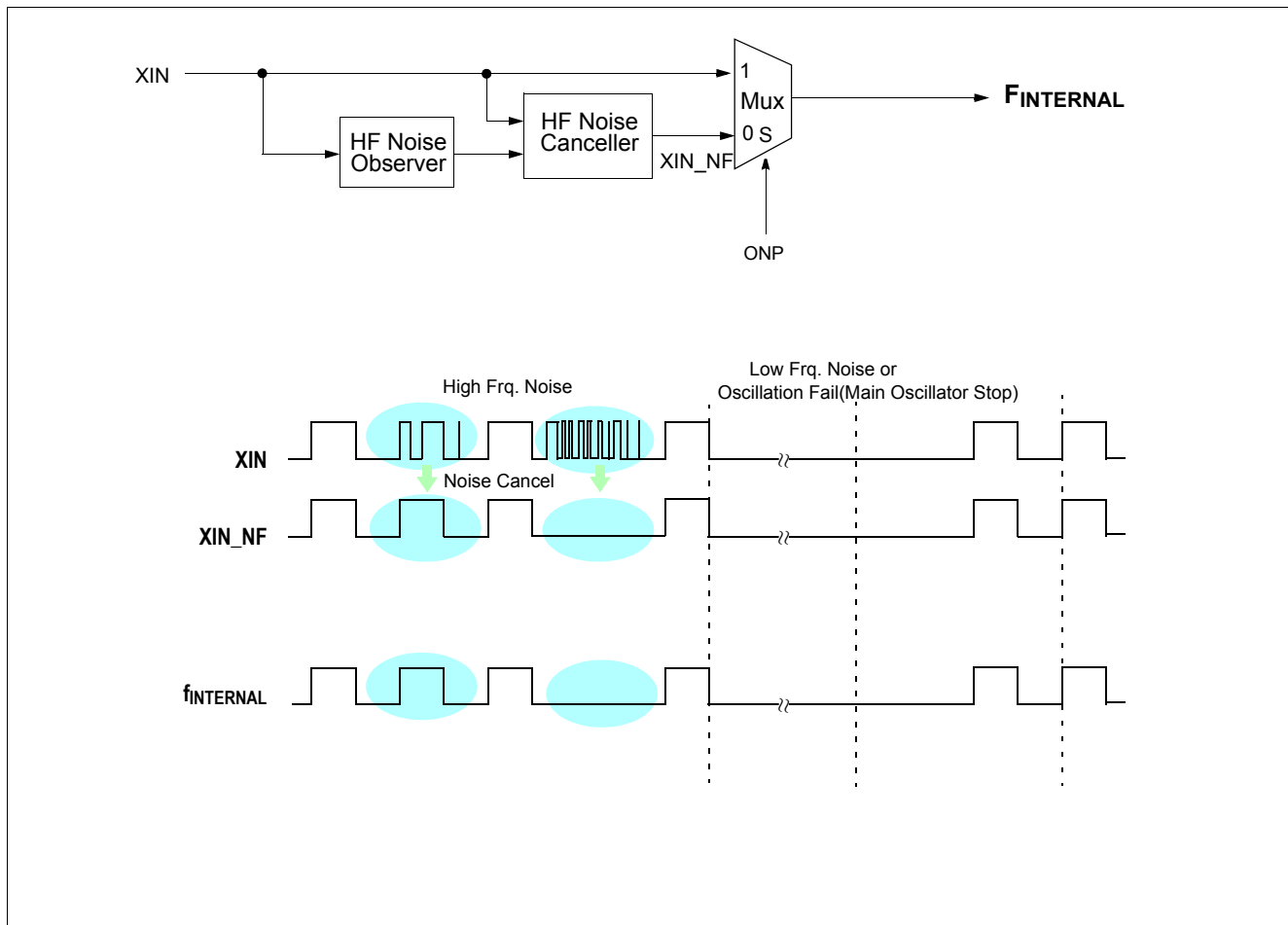

Figure 24-1 Block Diagram of ONP Respective Wave Forms

And this function can recover the external clock source when the external clock is recovered to normal state.

The “IN8MCLK”, “IN4MCLK”, “IN2MCLK”, “IN8MCLKXO”, “IN4MCLKXO”, “IN2MCLKXO” option of the Device Configuration Area enables the function to operate the device by using the internal oscillator clock

in ONP block as system clock. There is no need to connect the x-tal, resonator, RC and R externally. After selecting the this option, the period of internal oscillator clock could be checked by X_{OUT} outputting clock divided the internal oscillator clock by 4.

25. FLASH PROGRAMMING SPEC.

25.1 FLASH Configuration Byte

Except the user program memory, there is configuration byte(address 20C6H and 20C7H) for the selection of program lock, BIT clock selection, ONP, oscillation configuration and reset configuration. The configuration byte of FLASH is shown as Figure 25-1. It could be served when user use the FLASH programmer.

Note: The Configuration Option may not be read exactly when VDD rising time is very slow. It is recommended to adjust the VDD rising time faster than 40ms/V (200ms from 0V to 5V).

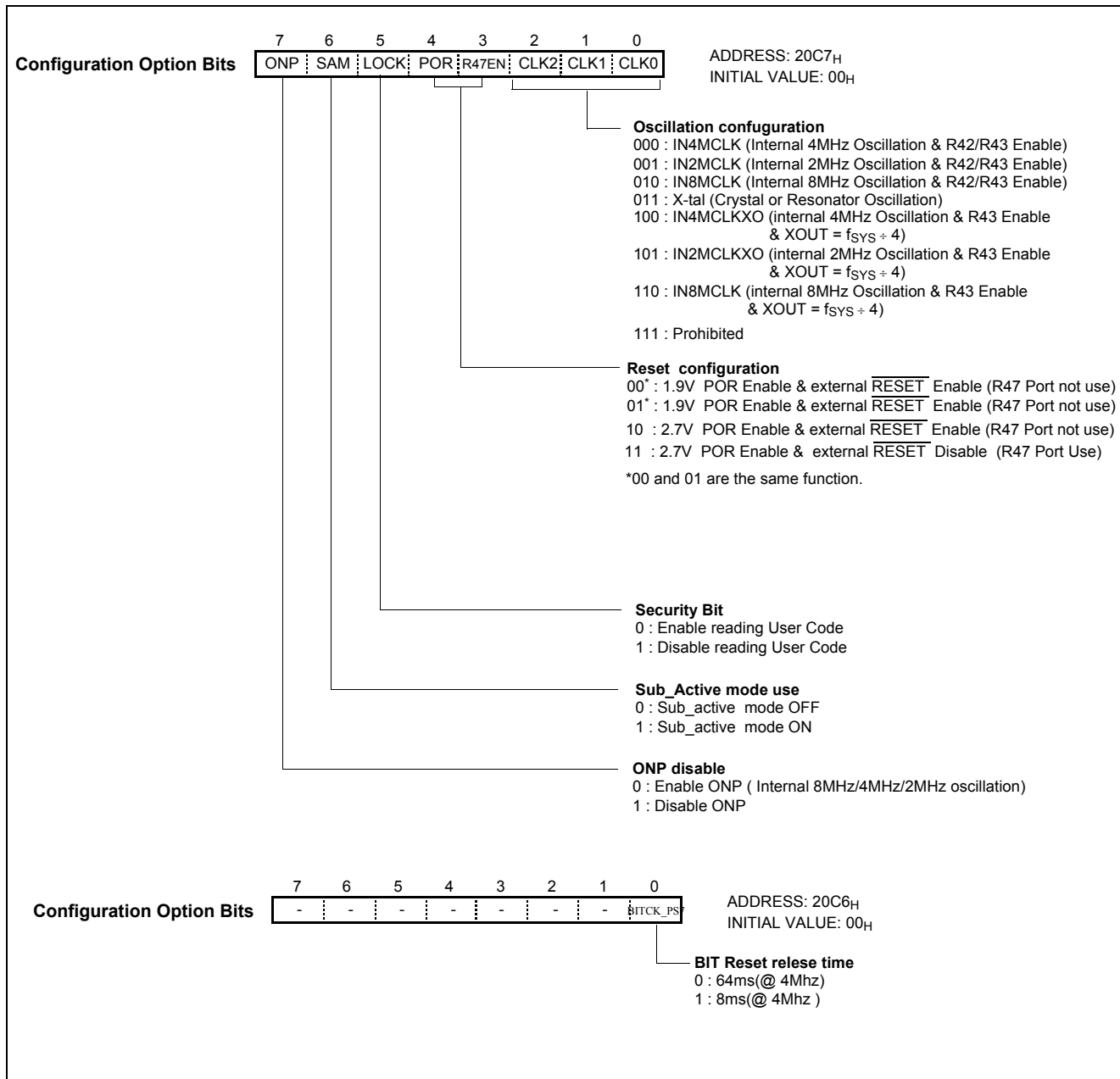

Figure 25-1 The FLASH Configuration Byte

25.2 FLASH Programming

The MC80F7708A is a MTP microcontroller. Its internal user memory is constructed with FLASH ROM.

Blank FLASH's internal memory is filled by 00_H, not FF_H.

Note: *In any case, you have to use the *.OTP file for programming, not the *.HEX file. After assemble, both OTP and HEX file are generated by automatically. The HEX file is used during program emulation on the emulator.*

How to Program

To program the FLASH or MTP devices, user can use ABOV own programmer.

ABOV own programmer list

Manufacturer: ABOV Semiconductor Programmer:

Choice-Sigma
StandAlone-Gang4
PGM-plus

The Choice-Sigma is a ABOV Universal Single Programmer for all of ABOV FLASH/OTP devices, also the StandAlone-Gang4

can program four FLASH/OTPs at once for ABOV device.

Ask to ABOV sales part for purchasing or more detail.

Programming Procedure

1. Select device MC80F7708A.
2. Load the *.OTP file from the PC. The file is composed of Motorola-S1 format.
3. Set the programming address range as below table.

Address	Set Value
Buffer start address	E000 _H
Buffer end address	FFFF _H
Device start address	E000 _H

4. Mount the socket adapter on the programmer.
5. Start program/verify.

26. EMULATOR EVA. BOARD SETTING

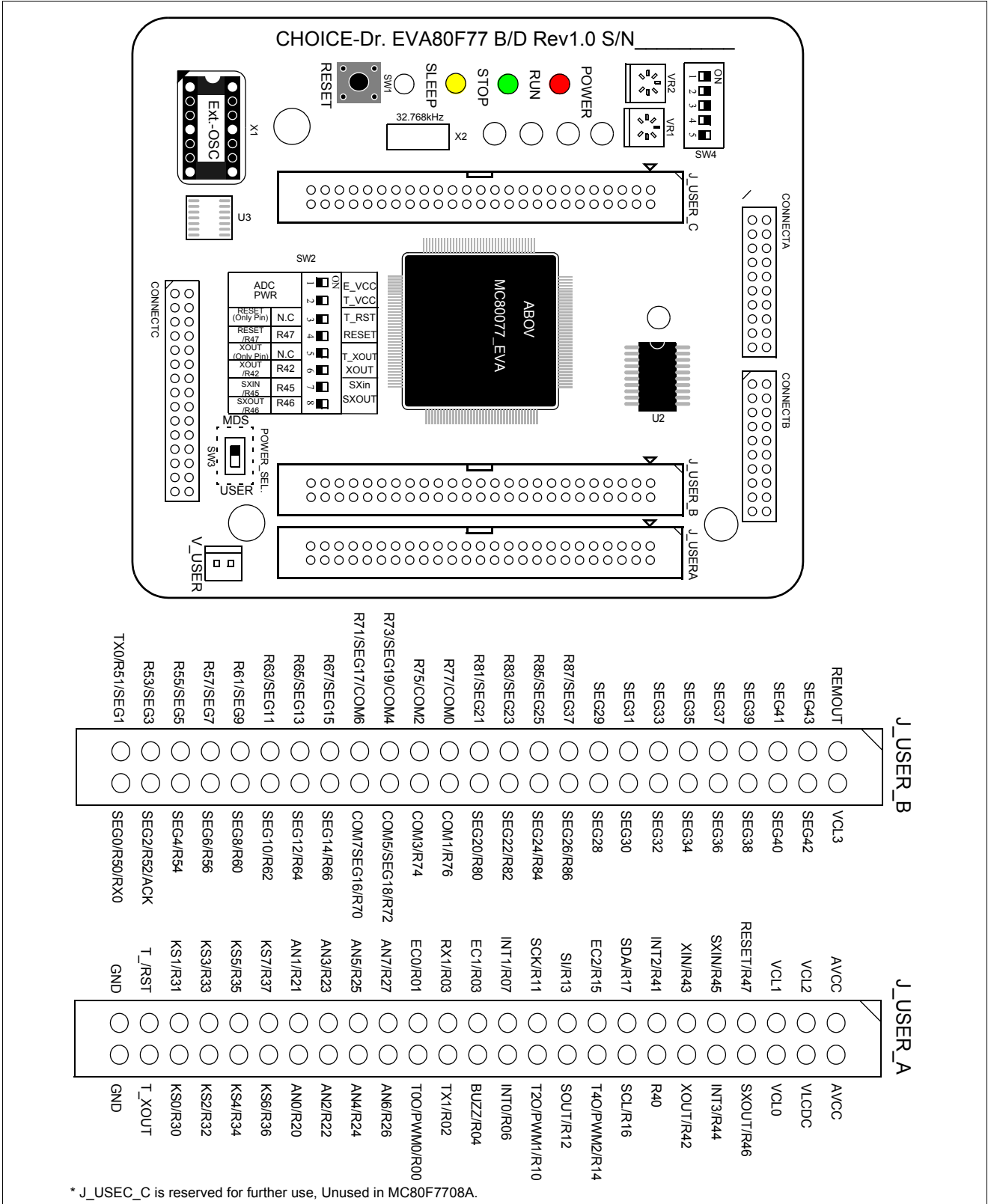

IP Switch and VR Setting

low configuration

Before execute the user program, keep in your mind the be-

DIP S/W, VR	Description	ON/OFF Setting
SW1	- Emulator Reset Switch. Reset the Emulator.	Reset the Emulator.
SW2	1 2 ADC voltage is supplied from EVA B/D voltage ADC voltage is supplied from Target(User POD pin) voltage 	SW2-1 must be ON position. SW2-2 must be OFF position.
	3 4 SW2-3 is NC pin. 	Normally OFF . EVA. chip can be reset by external user target board. SW2-3 ON : T_RST pin connected OFF : Disconnect circuit. SW2-4 ON : Reset is available by either user target system board or Emulator RESET switch. OFF : Reset the MCU by Emulator RESET switch. Does not work from user target board.
	5 6 SW2-5 is NC pin. POD XOUT pin configuration 	Normally OFF . MCU XOUT pin is disconnected internally in the Emulator. Some circumstance user may connect this circuit. SW2-5 ON : Output T_XOUT pin connected OFF : Disconnect circuit SW2-6 ON : Target board Port signal OFF : EVA board OSC XOUT
	7 8 SW2-7, SW2-8 select sub-clock function. 	SW2-7 ON : Target board Port signal OFF : EVA board Sub OSC SXIN SW2-8 ON : Target board Port signal OFF : EVA board Sub OSC SXOUT
SW3	1 This switch selects Eva. B/D Power supply source. 	Normally MDS . This switch selects Eva. B/D Power supply source.

DIP S/W, VR	Description	ON/OFF Setting
<p>SW4</p> <p>1 2 3 4 5 6</p>	<p>External Bias Resistors Connection</p> <p>SW4(Booster Mode) OFF ← ON SW4(External Divide Mode) OFF ← ON SW4 (Internal Divide Mode) OFF ← ON</p> <p>EVA. Chip Internal BIAS ← VCL3 ← VCL2 ← VCL1 ← VCL0 ← Vref 350kΩ 1MΩ V_{SS}</p> <p>SW4 SW4-1 SW4-2 SW4-3 SW4-4 SW4-5 SW4-6</p> <p>V_{DD} Adjust Contrast VR1 1MΩ 350kΩ × 3 0.47uF × 3 Adjust Contrast VR2 1MΩ External Resistor and Capacitor</p>	<p>Must be ON position. It serves the external bias resistors. If this switches are turned off, LCD bias voltage does not supplied, floated because there are no internal bias resistors and bias Tr. inside the Emulator.</p>
<p>VR1</p> <p>-</p>	<p>External Driver Mode : Adjust the LCD contrast. It supply bias voltage and adjust the VCL1 voltage.</p> <p>EVA. Chip Internal BIAS ← VCL3 ← VCL2 ← VCL1 ← VCL0 ← Vref 350kΩ</p> <p>V_{DD} Adjust Contrast VR1 1MΩ SW4-1 SW4-2 SW4-3 SW4-4 SW4-5 350kΩ × 2 0.47uF × 3 External Resistor and Capacitor</p>	<p>Adjust the proper position as well as LCD display good.</p>

DIP S/W, VR	Description	ON/OFF Setting
<p>VR2</p> <p>-</p>	<p>Internal boost mode : Adjust the LCD contrast. It supply bias voltage and adjust the VCL1 voltage.</p>	<p>Adjust the proper position as well as LCD display good.</p>

27. IN-SYSTEM PROGRAMMING

27.1 Getting Started / Installation

The In-System Programming (ISP) is performed without removing the microcontroller from the system. The In-System Programming(ISP) facility consists of a series of internal hardware resources coupled with internal firm-ware through the serial port. The In-System Programming (ISP) facility has made in-circuit programming in an embedded application possible with a minimum of additional expense in components and circuit board area. The following section details the procedure for accomplishing the installation procedure.

1. Power off a target system.

2. Configure a target system as ISP mode.

Refer to “27.3 Hardware Conditions to Enter the ISP Mode”

3. Attach a USB-SIO-ISP B/D into a target system.

4. Run the ABOV USB-SIO-ISP software.

- Download the ISP S/W from <http://www.abov.co.kr>.
- Unzip the download file and run USB-SIO-ISP.exe

5. Select a device in the USB-SIO-ISP S/W.

6. Power on a target system.

7. Execute ISP command such as read, program, auto... by pressing buttons on the USB-SIO-ISP S/W.

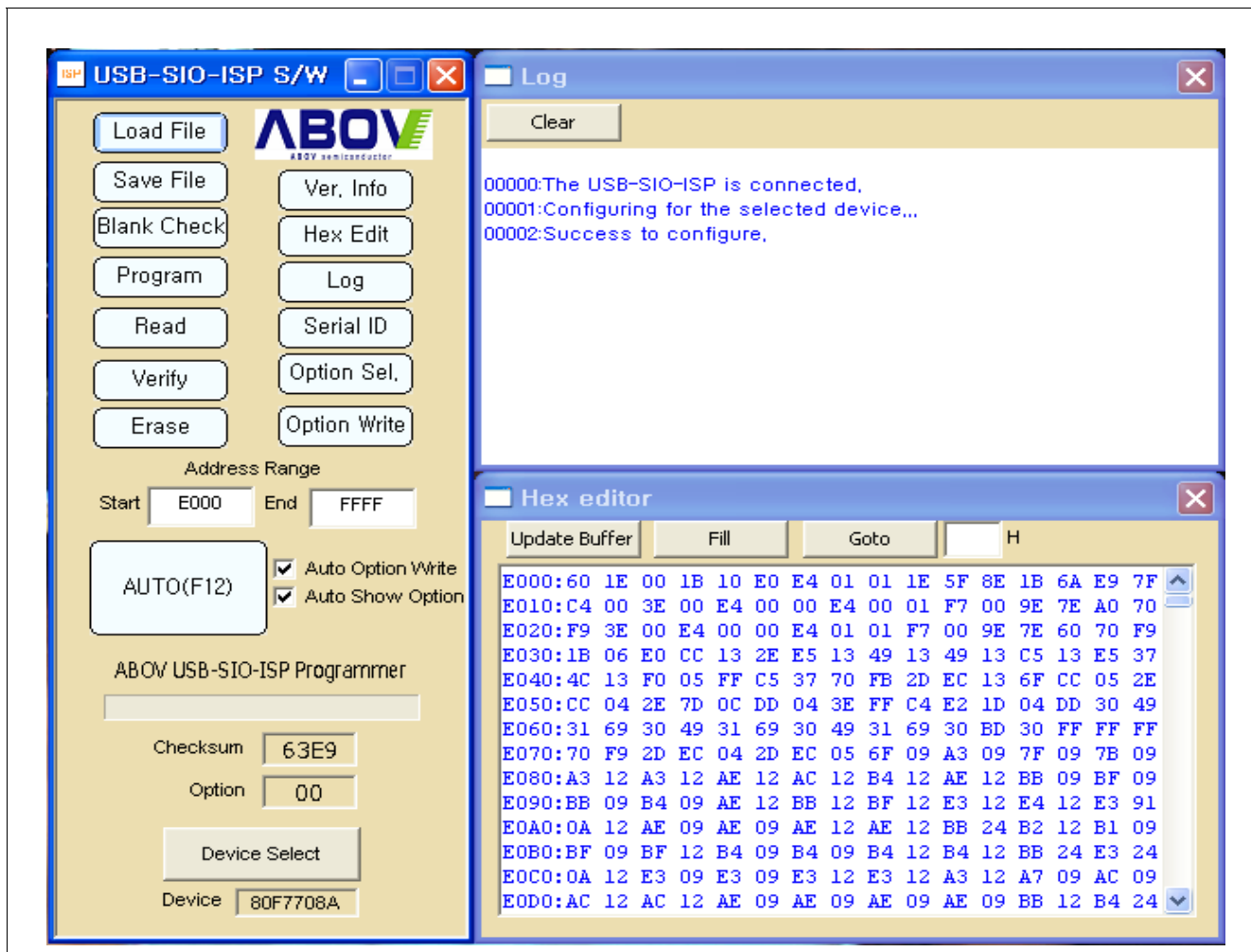

Figure 27-1 ISP software

27.2 Basic ISP S/W Information

The Figure 27-1 is the ISP software based on Windows™. This software is only supporting devices with ISO. In case

of not detecting its baudrates an user manually have to select specific baudrates.

Function	Description
Load File	Load the data from the selected file storage into the memory buffer.
Save File	Save the current data in your memory buffer to a disk storage by using the Intel Motorola HEX format.
Blank Check	Verify whether or not a device is in an erased or unprogrammed state.
Program	This button enables you to place new data from the memory buffer into the target device.
Read	Read the data in the target MCU into the buffer for examination. The checksum will be displayed on the checksum box.
Verify	Assures that data in the device matches data in the memory buffer. If your device is secured, a verification error is detected.
Erase	Erase the data in your target MCU before programming it.
Option Selection	Set the configuration data of target MCU. The security locking is set with this button.
Option Write	Program the configuration data of target MCU. The security locking is performed with this button.
Start _____	Starting address
End _____	End address
AUTO	Following sequence is performed ; 1.Erase 2.Program 3.Verify 4.Option Write
Auto Option Write	If you want to program the option(config) value after pressing the Auto Button, chek this button
Auto Show Option	If you check this button, the option(config) dialog is displayed whenever pressing the Auto button.
Checksum	Display the checksum(Hexdecimal) after reading the target device.
Select Device	Select target device. You need to select a device before turning on the target VDD
Update Buffer	Update buffer by pressing this button.
Fill	Fill the selected area with a data.
Goto	Display the selected page.
Serial ID	To program the serial ID.

Table 27-1 ISP Function Description

Note: MCU configuration value is erased after operation. It must be configured to match with user target board. Otherwise, it is failed to enter ISP mode, or its operation is not de-

scribable.

27.3 Hardware Conditions to Enter the ISP Mode

The boot loader can be executed by holding $\overline{\text{RESET}}/\text{V}_{\text{PP}}$ and $\overline{\text{RESET}}/\text{V}_{\text{PP}}$ as +9V. The ISP function uses following pins: SCL, SDA,

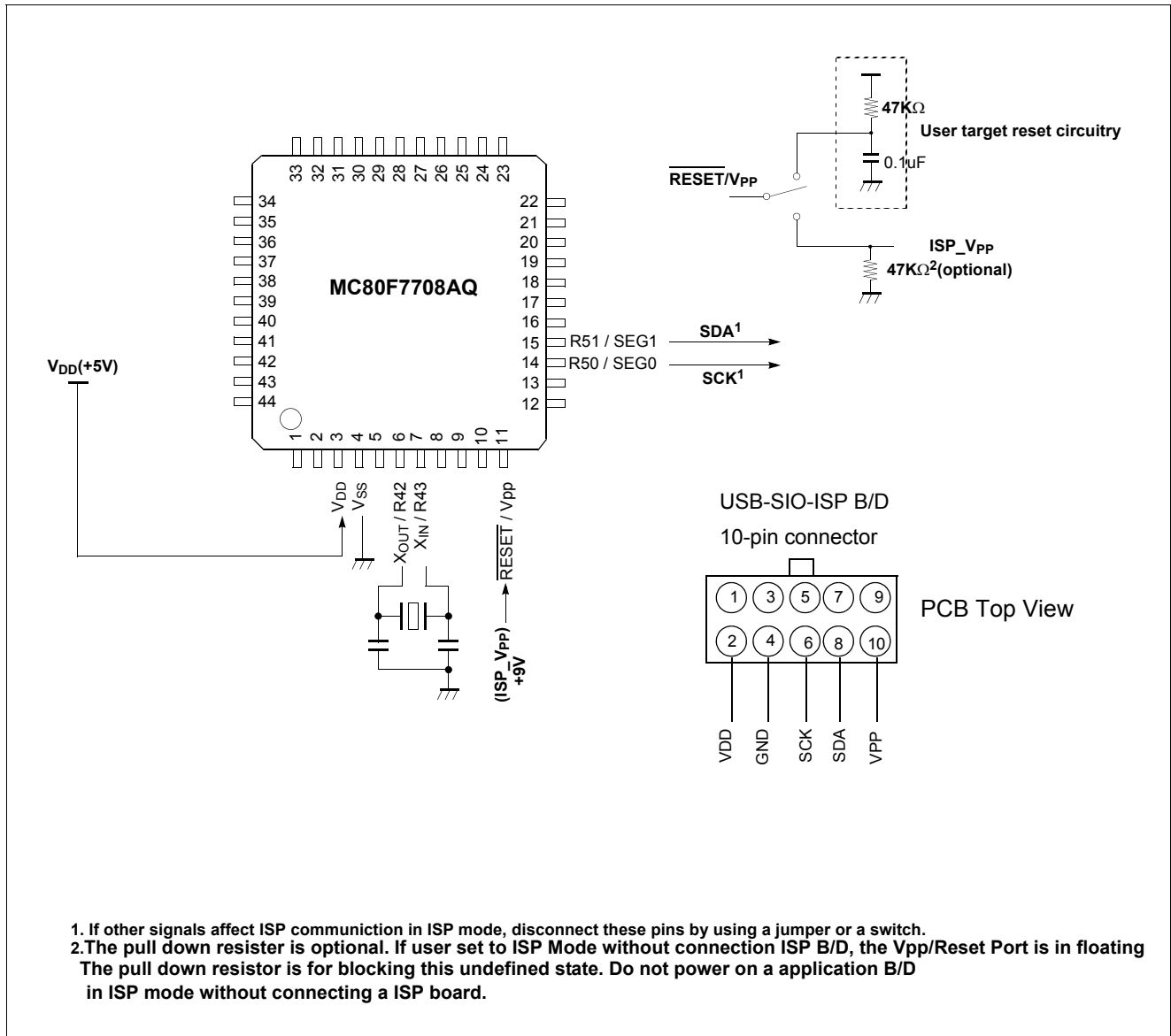

Figure 27-2 ISP Configuration

27.4 Sequence to enter ISP mode/user mode

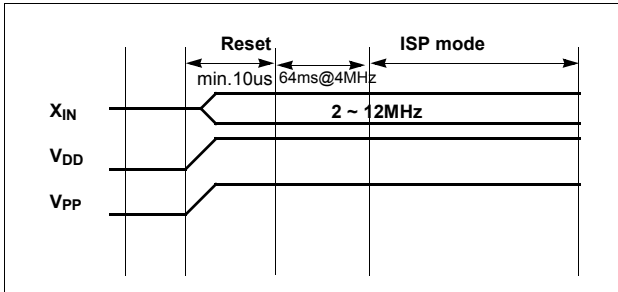

Figure 27-3 Timing diagram to enter the ISP mode

Sequence to enter ISP mode from user mode.

1. Power off a target system.
2. Configure a target system as ISP mode.
3. Attach a ISP B/D into a target system.
4. Run the ISP S/W and Select Device.
5. Power on a target system.

Sequence to enter user mode from ISP mode.

1. Close the ISP S/W.
2. Power off a target system.
3. Configure a target system as user mode
4. Detach a ISP B/D from a target system.
5. Power on.

27.5 Reference ISP Circuit Diagram and ABOV Supplied ISP Board

The ISP software and hardware circuit diagram are provided at www.abov.co.kr.

To get a ISP B/D, contact to sales department. The following circuit diagram is for reference use.

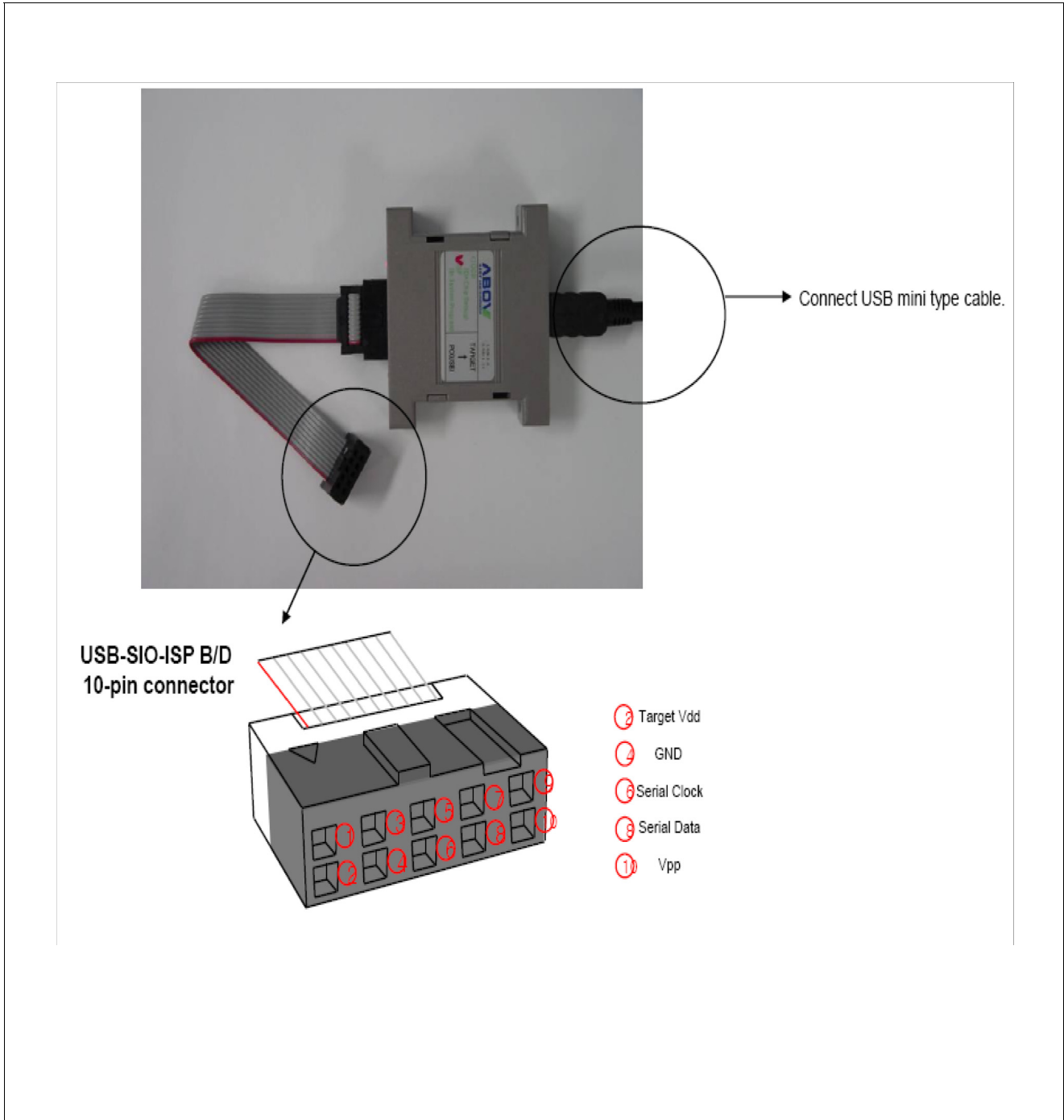
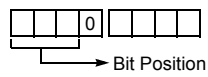
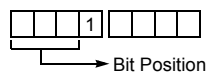

Figure 27-4 ISP board supplied by ABOV

APPENDIX

A. INSTRUCTION

A.1 Terminology List

Terminology	Description
A	Accumulator
X	X - register
Y	Y - register
PSW	Program Status Word
#imm	8-bit Immediate data
dp	Direct Page Offset Address
!abs	Absolute Address
[]	Indirect expression
{}	Register Indirect expression
{ }+	Register Indirect expression, after that, Register auto-increment
.bit	Bit Position
A.bit	Bit Position of Accumulator
dp.bit	Bit Position of Direct Page Memory
M.bit	Bit Position of Memory Data (000H~0FFFH)
rel	Relative Addressing Data
upage	U-page (0FF00H~0FFFFH) Offset Address
n	Table CALL Number (0~15)
+	Addition
x	 Upper Nibble Expression in Opcode
y	 Upper Nibble Expression in Opcode
-	Subtraction
×	Multiplication
/	Division
()	Contents Expression
^	AND
∨	OR
⊕	Exclusive OR
~	NOT
←	Assignment / Transfer / Shift Left
→	Shift Right
↔	Exchange
=	Equal
≠	Not Equal

A.2 Instruction Map

LOW HIGH	0000 00	00001 01	00010 02	00011 03	00100 04	00101 05	00110 06	00111 07	01000 08	01001 09	01010 0A	01011 0B	01100 0C	01101 0D	01110 0E	01111 0F
000	-	SET1 dp.bit	BBS A.bit,rel	BBS dp.bit,rel	ADC #imm	ADC dp	ADC dp+X	ADC !abs	ASL A	ASL dp	TCALL 0	SETA1 .bit	BIT dp	POP A	PUSH A	BRK
001	CLRC	"	"	"	SBC #imm	SBC dp	SBC dp+X	SBC !abs	ROL A	ROL dp	TCALL 2	CLRA1 .bit	COM dp	POP X	PUSH X	BRA rel
010	CLRG	"	"	"	CMP #imm	CMP dp	CMP dp+X	CMP !abs	LSR A	LSR dp	TCALL 4	NOT1 M.bit	TST dp	POP Y	PUSH Y	PCALL Upage
011	DI	"	"	"	OR #imm	OR dp	OR dp+X	OR !abs	ROR A	ROR dp	TCALL 6	OR1 OR1B	CMPX dp	POP PSW	PUSH PSW	RET
100	CLRV	"	"	"	AND #imm	AND dp	AND dp+X	AND !abs	INC A	INC dp	TCALL 8	AND1 AND1B	CMPY dp	CBNE dp+X	TXSP	INC X
101	SETC	"	"	"	EOR #imm	EOR dp	EOR dp+X	EOR !abs	DEC A	DEC dp	TCALL 10	EOR1 EOR1B	DBNE dp	XMA dp+X	TSPX	DEC X
110	SETG	"	"	"	LDA #imm	LDA dp	LDA dp+X	LDA !abs	TXA	LDY dp	TCALL 12	LDC LDCB	LDX dp	LDX dp+Y	XCN	DAS (N/A)
111	EI	"	"	"	LDM dp,#imm	STA dp	STA dp+X	STA !abs	TAX	STY dp	TCALL 14	STC M.bit	STX dp	STX dp+Y	XAX	STOP

LOW HIGH	10000 10	10001 11	10010 12	10011 13	10100 14	10101 15	10110 16	10111 17	11000 18	11001 19	11010 1A	11011 1B	11100 1C	11101 1D	11110 1E	11111 1F
000	BPL rel	CLR1 dp.bit	BBC A.bit,rel	BBC dp.bit,rel	ADC {X}	ADC !abs+Y	ADC [dp+X]	ADC [dp]+Y	ASL !abs	ASL dp+X	TCALL 1	JMP !abs	BIT !abs	ADDW dp	LDX #imm	JMP [!abs]
001	BVC rel	"	"	"	SBC {X}	SBC !abs+Y	SBC [dp+X]	SBC [dp]+Y	ROL !abs	ROL dp+X	TCALL 3	CALL !abs	TEST !abs	SUBW dp	LDY #imm	JMP [dp]
010	BCC rel	"	"	"	CMP {X}	CMP !abs+Y	CMP [dp+X]	CMP [dp]+Y	LSR !abs	LSR dp+X	TCALL 5	MUL	TCLR1 !abs	CMPW dp	CMPX #imm	CALL [dp]
011	BNE rel	"	"	"	OR {X}	OR !abs+Y	OR [dp+X]	OR [dp]+Y	ROR !abs	ROR dp+X	TCALL 7	DBNE Y	CMPX !abs	LDYA dp	CMPY #imm	RETI
100	BMI rel	"	"	"	AND {X}	AND !abs+Y	AND [dp+X]	AND [dp]+Y	INC !abs	INC dp+X	TCALL 9	DIV	CMPY !abs	INCW dp	INC Y	TAY
101	BVS rel	"	"	"	EOR {X}	EOR !abs+Y	EOR [dp+X]	EOR [dp]+Y	DEC !abs	DEC dp+X	TCALL 11	XMA {X}	XMA dp	DECW dp	DEC Y	TYA
110	BCS rel	"	"	"	LDA {X}	LDA !abs+Y	LDA [dp+X]	LDA [dp]+Y	LDY !abs	LDY dp+X	TCALL 13	LDA {X}+	LDX !abs	STYA dp	XAY	DAA (N/A)
111	BEQ rel	"	"	"	STA {X}	STA !abs+Y	STA [dp+X]	STA [dp]+Y	STY !abs	STY dp+X	TCALL 15	STA {X}+	STX !abs	CBNE dp	XYX	NOP

A.3 Instruction Set

Arithmetic / Logic Operation

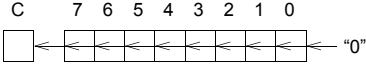
NO.	MNEMONIC	OP CODE	BYTE NO	CYCLE NO	OPERATION	FLAG NVGBHIZC
1	ADC #imm	04	2	2	Add with carry. $A \leftarrow (A) + (M) + C$	NV--H-ZC
2	ADC dp	05	2	3		
3	ADC dp + X	06	2	4		
4	ADC !abs	07	3	4		
5	ADC !abs + Y	15	3	5		
6	ADC [dp + X]	16	2	6		
7	ADC [dp] + Y	17	2	6		
8	ADC { X }	14	1	3		
9	AND #imm	84	2	2	Logical AND $A \leftarrow (A) \wedge (M)$	N-----Z-
10	AND dp	85	2	3		
11	AND dp + X	86	2	4		
12	AND !abs	87	3	4		
13	AND !abs + Y	95	3	5		
14	AND [dp + X]	96	2	6		
15	AND [dp] + Y	97	2	6		
16	AND { X }	94	1	3		
17	ASL A	08	1	2	Arithmetic shift left 	N-----ZC
18	ASL dp	09	2	4		
19	ASL dp + X	19	2	5		
20	ASL !abs	18	3	5		
21	CMP #imm	44	2	2	Compare accumulator contents with memory contents $(A) - (M)$	N-----ZC
22	CMP dp	45	2	3		
23	CMP dp + X	46	2	4		
24	CMP !abs	47	3	4		
25	CMP !abs + Y	55	3	5		
26	CMP [dp + X]	56	2	6		
27	CMP [dp] + Y	57	2	6		
28	CMP { X }	54	1	3		
29	CMPX #imm	5E	2	2	Compare X contents with memory contents $(X) - (M)$	N-----ZC
30	CMPX dp	6C	2	3		
31	CMPX !abs	7C	3	4		
32	CMPY #imm	7E	2	2	Compare Y contents with memory contents $(Y) - (M)$	N-----ZC
33	CMPY dp	8C	2	3		
34	CMPY !abs	9C	3	4		
35	COM dp	2C	2	4	1'S Complement : $(dp) \leftarrow \sim(dp)$	N-----Z-
36	DAA	DF	1	3	Decimal adjust for addition	N-----ZC
37	DAS	CF	1	3	Decimal adjust for subtraction	N-----ZC
38	DEC A	A8	1	2	Decrement $M \leftarrow (M) - 1$	N-----Z-
39	DEC dp	A9	2	4		
40	DEC dp + X	B9	2	5		
41	DEC !abs	B8	3	5		
42	DEC X	AF	1	2		
43	DEC Y	BE	1	2		
44	DIV	9B	1	12	Divide : YA / X Q: A, R: Y	NV--H-Z-

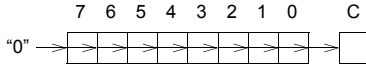
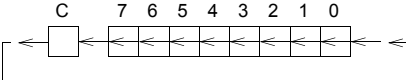
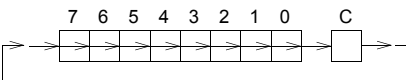
NO.	MNEMONIC	OP CODE	BYTE NO	CYCLE NO	OPERATION	FLAG NVGBHIZC	
45	EOR #imm	A4	2	2	Exclusive OR $A \leftarrow (A) \oplus (M)$	N-----Z-	
46	EOR dp	A5	2	3			
47	EOR dp + X	A6	2	4			
48	EOR !abs	A7	3	4			
49	EOR !abs + Y	B5	3	5			
50	EOR [dp + X]	B6	2	6			
51	EOR [dp] + Y	B7	2	6			
52	EOR { X }	B4	1	3	Increment $M \leftarrow (M) + 1$	N-----Z-	
53	INC A	88	1	2			
54	INC dp	89	2	4			
55	INC dp + X	99	2	5			
56	INC !abs	98	3	5	Logical shift right 	N-----ZC	
59	LSR A	48	1	2			
60	LSR dp	49	2	4			
61	LSR dp + X	59	2	5	Multiply : $YA \leftarrow Y \times A$	N-----Z-	
62	LSR !abs	58	3	5			
63	MUL	5B	1	9	Logical OR $A \leftarrow (A) \vee (M)$	N-----Z-	
64	OR #imm	64	2	2			
65	OR dp	65	2	3			
66	OR dp + X	66	2	4			
67	OR !abs	67	3	4			
68	OR !abs + Y	75	3	5			
69	OR [dp + X]	76	2	6			
70	OR [dp] + Y	77	2	6	Rotate left through carry 	N-----ZC	
72	ROL A	28	1	2			
73	ROL dp	29	2	4			
74	ROL dp + X	39	2	5	Rotate right through carry 	N-----ZC	
75	ROL !abs	38	3	5			
76	ROR A	68	1	2	Subtract with carry $A \leftarrow (A) - (M) - \sim(C)$	NV--HZC	
77	ROR dp	69	2	4			
78	ROR dp + X	79	2	5			
79	ROR !abs	78	3	5	Test memory contents for negative or zero (dp) - 00 _H		N-----Z-
80	SBC #imm	24	2	2			
81	SBC dp	25	2	3			
82	SBC dp + X	26	2	4			
83	SBC !abs	27	3	4			
84	SBC !abs + Y	35	3	5			
85	SBC [dp + X]	36	2	6			
86	SBC [dp] + Y	37	2	6	Exchange nibbles within the accumulator $A_7 \sim A_4 \leftrightarrow A_3 \sim A_0$	N-----Z-	
87	SBC { X }	34	1	3			
88	TST dp	4C	2	3	Exchange nibbles within the accumulator $A_7 \sim A_4 \leftrightarrow A_3 \sim A_0$	N-----Z-	
89	XCN	CE	1	5			

Register / Memory Operation

NO.	MNEMONIC	OP CODE	BYTE NO	CYCLE NO	OPERATION	FLAG NVGBHIZC
1	LDA #imm	C4	2	2	Load accumulator $A \leftarrow (M)$	N-----Z-
2	LDA dp	C5	2	3		
3	LDA dp + X	C6	2	4		
4	LDA !abs	C7	3	4		
5	LDA !abs + Y	D5	3	5		
6	LDA [dp + X]	D6	2	6		
7	LDA [dp] + Y	D7	2	6		
8	LDA { X }	D4	1	3		
9	LDA { X }+	DB	1	4		
10	LDM dp,#imm	E4	3	5	Load memory with immediate data : $(M) \leftarrow \text{imm}$	-----
11	LDX #imm	1E	2	2	Load X-register $X \leftarrow (M)$	N-----Z-
12	LDX dp	CC	2	3		
13	LDX dp + Y	CD	2	4		
14	LDX !abs	DC	3	4		
15	LDY #imm	3E	2	2	Load Y-register $Y \leftarrow (M)$	N-----Z-
16	LDY dp	C9	2	3		
17	LDY dp + X	D9	2	4		
18	LDY !abs	D8	3	4		
19	STA dp	E5	2	4	Store accumulator contents in memory $(M) \leftarrow A$	-----
20	STA dp + X	E6	2	5		
21	STA !abs	E7	3	5		
22	STA !abs + Y	F5	3	6		
23	STA [dp + X]	F6	2	7		
24	STA [dp] + Y	F7	2	7		
25	STA { X }	F4	1	4		
26	STA { X }+	FB	1	4	X- register auto-increment : $(M) \leftarrow A$, $X \leftarrow X + 1$	
27	STX dp	EC	2	4	Store X-register contents in memory $(M) \leftarrow X$	-----
28	STX dp + Y	ED	2	5		
29	STX !abs	FC	3	5		
30	STY dp	E9	2	4	Store Y-register contents in memory $(M) \leftarrow Y$	-----
31	STY dp + X	F9	2	5		
32	STY !abs	F8	3	5		
33	TAX	E8	1	2	Transfer accumulator contents to X-register : $X \leftarrow A$	N-----Z-
34	TAY	9F	1	2	Transfer accumulator contents to Y-register : $Y \leftarrow A$	N-----Z-
35	TSPX	AE	1	2	Transfer stack-pointer contents to X-register : $X \leftarrow \text{sp}$	N-----Z-
36	TXA	C8	1	2	Transfer X-register contents to accumulator: $A \leftarrow X$	N-----Z-
37	TXSP	8E	1	2	Transfer X-register contents to stack-pointer: $\text{sp} \leftarrow X$	N-----Z-
38	TYA	BF	1	2	Transfer Y-register contents to accumulator: $A \leftarrow Y$	N-----Z-
39	XAX	EE	1	4	Exchange X-register contents with accumulator : $X \leftrightarrow A$	-----
40	XAY	DE	1	4	Exchange Y-register contents with accumulator : $Y \leftrightarrow A$	-----
41	XMA dp	BC	2	5	Exchange memory contents with accumulator $(M) \leftrightarrow A$	N-----Z-
42	XMA dp+X	AD	2	6		
43	XMA {X}	BB	1	5		
44	XYX	FE	1	4		

16-BIT Operation

NO.	MNEMONIC	OP CODE	BYTE NO	CYCLE NO	OPERATION	FLAG NVGBHIZC
1	ADDW dp	1D	2	5	16-Bits add without carry $YA \leftarrow (YA) + (dp + 1)(dp)$	NV--H-ZC
2	CMPW dp	5D	2	4	Compare YA contents with memory pair contents : $(YA) - (dp+1)(dp)$	N-----ZC
3	DECW dp	BD	2	6	Decrement memory pair $(dp+1)(dp) \leftarrow (dp+1)(dp) - 1$	N-----Z-
4	INCW dp	9D	2	6	Increment memory pair $(dp+1)(dp) \leftarrow (dp+1)(dp) + 1$	N-----Z-
5	LDYA dp	7D	2	5	Load YA $YA \leftarrow (dp + 1)(dp)$	N-----Z-
6	STYA dp	DD	2	5	Store YA $(dp + 1)(dp) \leftarrow YA$	-----
7	SUBW dp	3D	2	5	16-Bits subtract without carry $YA \leftarrow (YA) - (dp + 1)(dp)$	NV--H-ZC

Bit Manipulation

NO.	MNEMONIC	OP CODE	BYTE NO	CYCLE NO	OPERATION	FLAG NVGBHIZC
1	AND1 M.bit	8B	3	4	Bit AND C-flag : $C \leftarrow (C) \wedge (M.bit)$	-----C
2	AND1B M.bit	8B	3	4	Bit AND C-flag and NOT : $C \leftarrow (C) \wedge \sim(M.bit)$	-----C
3	BIT dp	0C	2	4	Bit test A with memory :	MM----Z-
4	BIT labs	1C	3	5	$Z \leftarrow (A) \wedge (M), N \leftarrow (M_7), V \leftarrow (M_6)$	
5	CLR1 dp.bit	y1	2	4	Clear bit : $(M.bit) \leftarrow "0"$	-----
6	CLRA1 A.bit	2B	2	2	Clear A bit : $(A.bit) \leftarrow "0"$	-----
7	CLRC	20	1	2	Clear C-flag : $C \leftarrow "0"$	-----0
8	CLRG	40	1	2	Clear G-flag : $G \leftarrow "0"$	--0-----
9	CLRV	80	1	2	Clear V-flag : $V \leftarrow "0"$	-0--0---
10	EOR1 M.bit	AB	3	5	Bit exclusive-OR C-flag : $C \leftarrow (C) \oplus (M.bit)$	-----C
11	EOR1B M.bit	AB	3	5	Bit exclusive-OR C-flag and NOT : $C \leftarrow (C) \oplus \sim(M.bit)$	-----C
12	LDC M.bit	CB	3	4	Load C-flag : $C \leftarrow (M.bit)$	-----C
13	LDCB M.bit	CB	3	4	Load C-flag with NOT : $C \leftarrow \sim(M.bit)$	-----C
14	NOT1 M.bit	4B	3	5	Bit complement : $(M.bit) \leftarrow \sim(M.bit)$	-----
15	OR1 M.bit	6B	3	5	Bit OR C-flag : $C \leftarrow (C) \vee (M.bit)$	-----C
16	OR1B M.bit	6B	3	5	Bit OR C-flag and NOT : $C \leftarrow (C) \vee \sim(M.bit)$	-----C
17	SET1 dp.bit	x1	2	4	Set bit : $(M.bit) \leftarrow "1"$	-----
18	SETA1 A.bit	0B	2	2	Set A bit : $(A.bit) \leftarrow "1"$	-----
19	SETC	A0	1	2	Set C-flag : $C \leftarrow "1"$	-----1
20	SETG	C0	1	2	Set G-flag : $G \leftarrow "1"$	--1-----
21	STC M.bit	EB	3	6	Store C-flag : $(M.bit) \leftarrow C$	-----
22	TCLR1 labs	5C	3	6	Test and clear bits with A : $A - (M), (M) \leftarrow (M) \wedge \sim(A)$	N-----Z-
23	TSET1 labs	3C	3	6	Test and set bits with A : $A - (M), (M) \leftarrow (M) \vee (A)$	N-----Z-

Branch / Jump Operation

NO.	MNEMONIC	OP CODE	BYTE NO	CYCLE NO	OPERATION	FLAG NVGBHIZC
1	BBC A.bit,rel	y2	2	4/6	Branch if bit clear :	-----
2	BBC dp.bit,rel	y3	3	5/7	if (bit) = 0 , then pc ← (pc) + rel	-----
3	BBS A.bit,rel	x2	2	4/6	Branch if bit set :	-----
4	BBS dp.bit,rel	x3	3	5/7	if (bit) = 1 , then pc ← (pc) + rel	-----
5	BCC rel	50	2	2/4	Branch if carry bit clear if (C) = 0 , then pc ← (pc) + rel	-----
6	BCS rel	D0	2	2/4	Branch if carry bit set if (C) = 1 , then pc ← (pc) + rel	-----
7	BEQ rel	F0	2	2/4	Branch if equal if (Z) = 1 , then pc ← (pc) + rel	-----
8	BMI rel	90	2	2/4	Branch if minus if (N) = 1 , then pc ← (pc) + rel	-----
9	BNE rel	70	2	2/4	Branch if not equal if (Z) = 0 , then pc ← (pc) + rel	-----
10	BPL rel	10	2	2/4	Branch if minus if (N) = 0 , then pc ← (pc) + rel	-----
11	BRA rel	2F	2	4	Branch always pc ← (pc) + rel	-----
12	BVC rel	30	2	2/4	Branch if overflow bit clear if (V) = 0 , then pc ← (pc) + rel	-----
13	BVS rel	B0	2	2/4	Branch if overflow bit set if (V) = 1 , then pc ← (pc) + rel	-----
14	CALL !abs	3B	3	8	Subroutine call	-----
15	CALL [dp]	5F	2	8	M(sp) ← (pc _H) , sp ← sp - 1 , M(sp) ← (pc _L) , sp ← sp - 1 , if !abs, pc ← abs ; if [dp], pc _L ← (dp) , pc _H ← (dp + 1) .	-----
16	CBNE dp,rel	FD	3	5/7	Compare and branch if not equal :	-----
17	CBNE dp+X,rel	8D	3	6/8	if (A) ≠ (M) , then pc ← (pc) + rel.	-----
18	DBNE dp,rel	AC	3	5/7	Decrement and branch if not equal :	-----
19	DBNE Y,rel	7B	2	4/6	if (M) ≠ 0 , then pc ← (pc) + rel.	-----
20	JMP !abs	1B	3	3	Unconditional jump pc ← jump address	-----
21	JMP [!abs]	1F	3	5		
22	JMP [dp]	3F	2	4		
23	PCALL upage	4F	2	6	U-page call M(sp) ← (pc _H) , sp ← sp - 1 , M(sp) ← (pc _L) , sp ← sp - 1 , pc _L ← (upage) , pc _H ← "OFFH" .	-----
24	TCALL n	nA	1	8	Table call : (sp) ← (pc _H) , sp ← sp - 1 , M(sp) ← (pc _L) , sp ← sp - 1 , pc _L ← (Table vector L) , pc _H ← (Table vector H)	-----

Control Operation & Etc.

NO.	MNEMONIC	OP CODE	BYTE NO	CYCLE NO	OPERATION	FLAG NVGBHIZC
1	BRK	0F	1	8	Software interrupt : $B \leftarrow "1"$, $M(sp) \leftarrow (pc_H)$, $sp \leftarrow sp-1$, $M(s) \leftarrow (pc_L)$, $sp \leftarrow sp - 1$, $M(sp) \leftarrow (PSW)$, $sp \leftarrow sp - 1$, $pc_L \leftarrow (0FFDE_H)$, $pc_H \leftarrow (0FFDF_H)$.	---1-0--
2	DI	60	1	3	Disable interrupts : $I \leftarrow "0"$	-----0--
3	EI	E0	1	3	Enable interrupts : $I \leftarrow "1"$	-----1--
4	NOP	FF	1	2	No operation	-----
5	POP A	0D	1	4	$sp \leftarrow sp + 1$, $A \leftarrow M(sp)$ $sp \leftarrow sp + 1$, $X \leftarrow M(sp)$ $sp \leftarrow sp + 1$, $Y \leftarrow M(sp)$ $sp \leftarrow sp + 1$, $PSW \leftarrow M(sp)$	-----
6	POP X	2D	1	4		
7	POP Y	4D	1	4		
8	POP PSW	6D	1	4		
9	PUSH A	0E	1	4	$M(sp) \leftarrow A$, $sp \leftarrow sp - 1$	-----
10	PUSH X	2E	1	4	$M(sp) \leftarrow X$, $sp \leftarrow sp - 1$	
11	PUSH Y	4E	1	4	$M(sp) \leftarrow Y$, $sp \leftarrow sp - 1$	
12	PUSH PSW	6E	1	4	$M(sp) \leftarrow PSW$, $sp \leftarrow sp - 1$	
13	RET	6F	1	5	Return from subroutine $sp \leftarrow sp + 1$, $pc_L \leftarrow M(sp)$, $sp \leftarrow sp + 1$, $pc_H \leftarrow M(sp)$	-----
14	RETI	7F	1	6	Return from interrupt $sp \leftarrow sp + 1$, $PSW \leftarrow M(sp)$, $sp \leftarrow sp + 1$, $pc_L \leftarrow M(sp)$, $sp \leftarrow sp + 1$, $pc_H \leftarrow M(sp)$	restored
15	STOP	EF	1	3	Stop mode (halt CPU, stop oscillator)	-----