



## MC8200/MC7200 Series

The MTTL complex functions are designed for digital applications in the medium to high-speed range.

These MTTL devices provide significant reduction in package count and increased logic per function over devices in the basic MTTL and MDTL families.

## INDEX

Function	Operating Temperature Range		Packages		
	-55°C TO +125°C	0°C TO +70°C	Dual-in-line		Flat
			Plastic	Ceramic	
Dual 5 Bit Buffer Register	MC8200	MC7200	P	L	F
Dual 5 Bit Buffer Register W/D Inputs	MC8201	MC7201	P	L	F
10 Bit Buffer Register	MC8202	MC7202	P	L	F
10 Bit Buffer Register W/D Inputs	MC8203	MC7203	P	L	F
2 Input 4-Bit Digital Multiplexer	MC8233	MC7233	P	L	F
2 Input 4-Bit Digital Multiplexer	MC8234	MC7234	P	L	F
2 Input 4-Bit Digital Multiplexer	MC8235	MC7235	P	L	F
Quad Exclusive OR	MC8241	MC7241	P	L	F
Quad Exclusive NOR	MC8242	MC7242	P	L	F
Binary To Octal Decoder	MC8250	MC7250	P	L	F
BCD To Decimal Decoder	MC8251	MC7251	P	L	F
Arithmetic Logic Unit	MC8260	MC7260	P	L	F
Fast Carry Extender	MC8361	MC7261	P	L	F
2 Input 4-Bit Digital Multiplexer	MC8266	MC7266	P	L	F
2 Input 4-Bit Digital Multiplexer	MC8267	MC7267	P	L	F
4 Bit Shift Register	MC8270	MC7270	P	L	F
4 Bit Shift Register	MC8271	MC7271	P	L	F
Presetable Decode Counter	MC8280	MC7280	P	L	F
Presetable Binary Counter	MC8281	MC7281	P	L	F
Binary Up/Down Counter	MC8284	MC7284	P	L	F
Decade Up/Down Counter	MC8285	MC7285	P	L	F
Divide by Twelve Counter	MC8288	MC7288	P	L	F
Presetable High Speed Decade Counter	MC8290	MC7290	P	L	F
Presetable High Speed Binary Counter	MC8291	MC7291	P	L	F

## MC8200 • MC8201 • MC8202 • MC8203 BUFFER REGISTERS

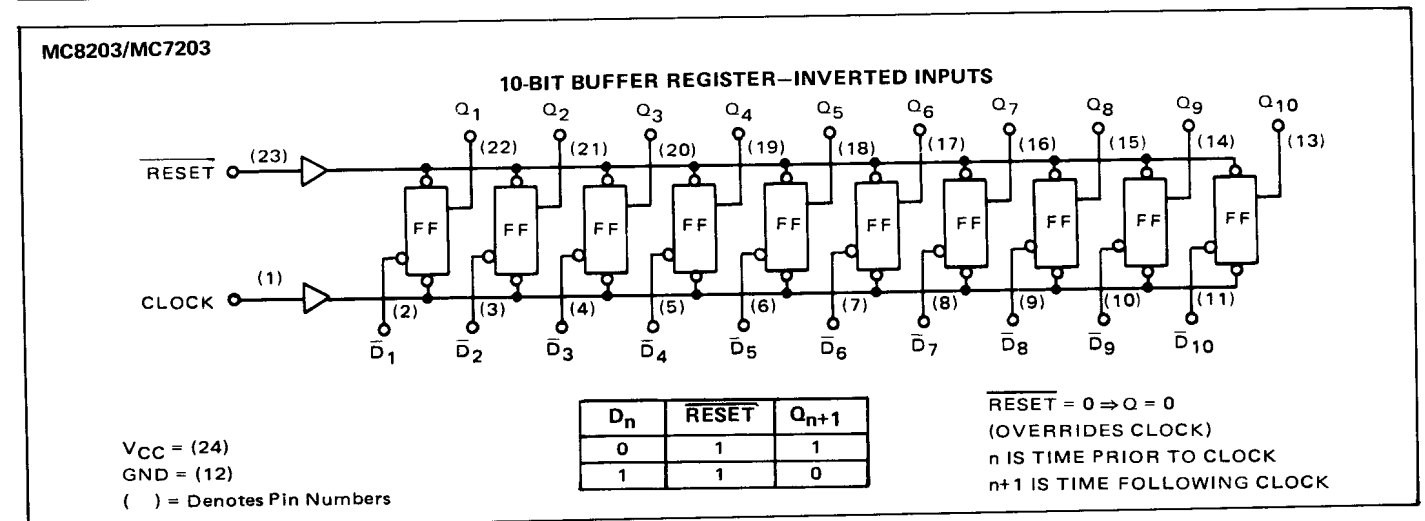
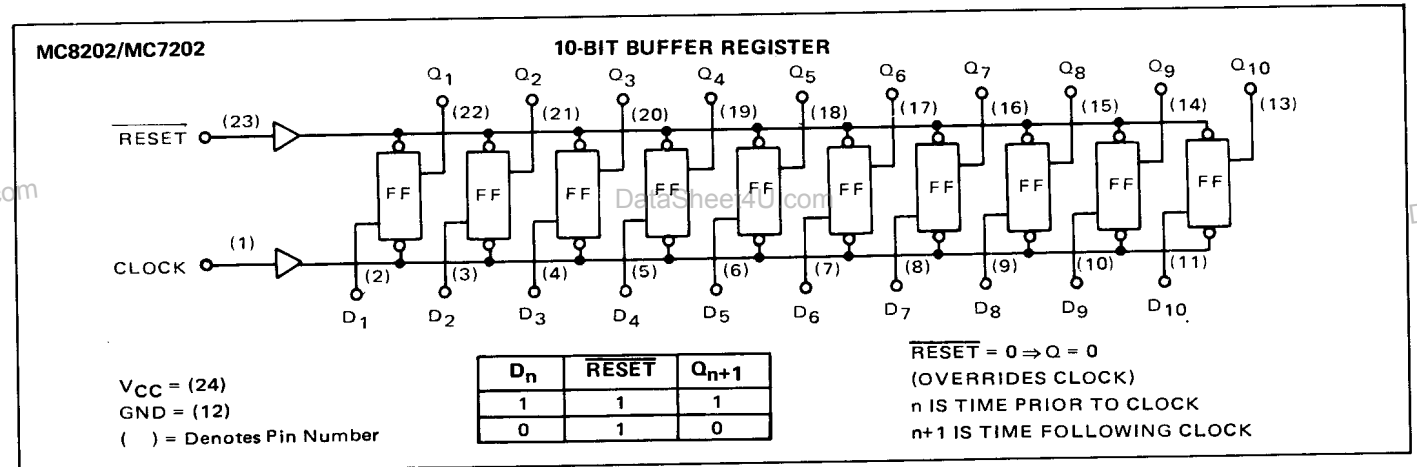
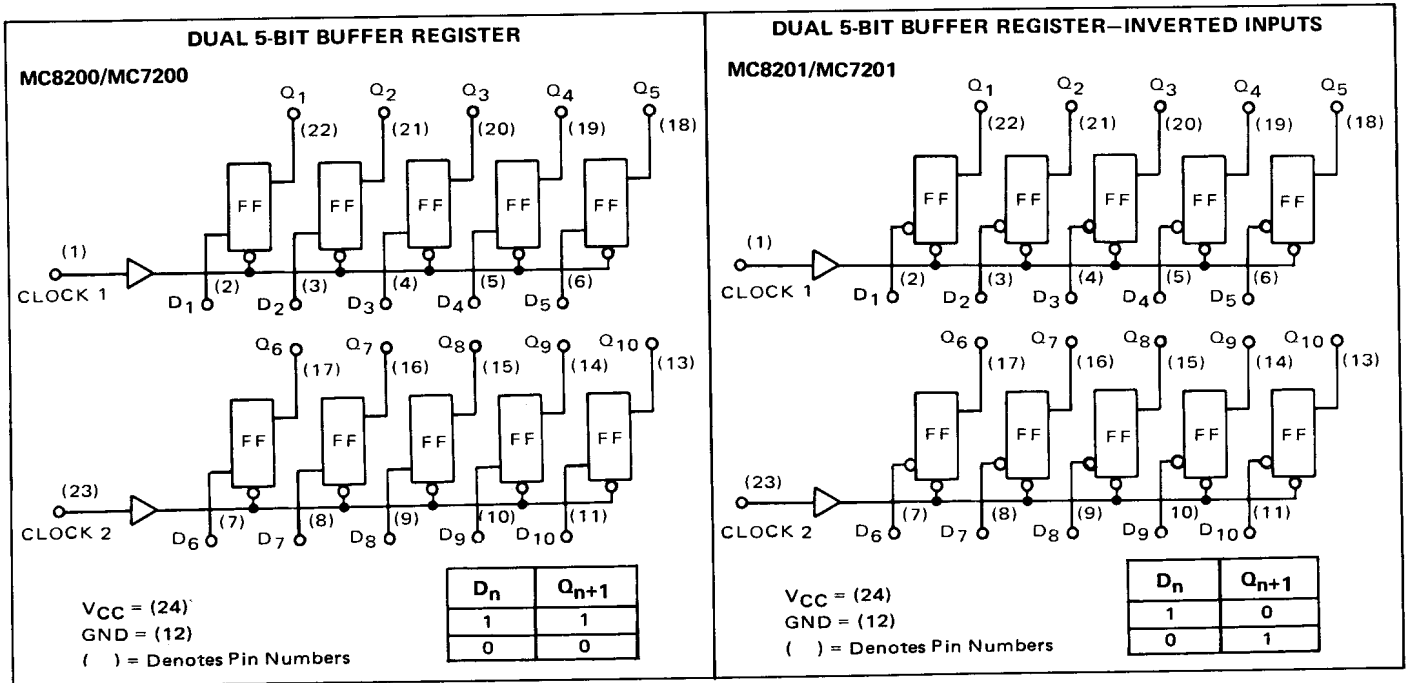

MC8233 • MC8234 • MC8235 2-INPUT 4-BIT DIGITAL MULTIPLEXER

MC8233/MC7233 (ACTIVE PULL-UP)

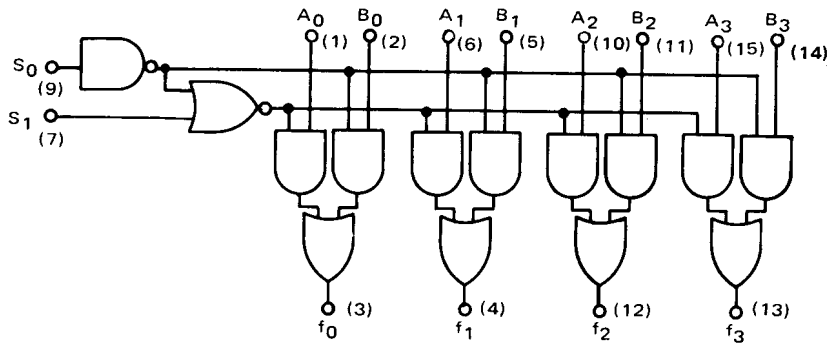

S <sub>0</sub>	S <sub>1</sub>	f <sub>n</sub>
0	0	A
1	0	A
0	1	B
1	1	0

V<sub>CC</sub> = (16)  
 GND = (8)  
 ( ) = Denotes Pin Numbers

MC8234/MC7234 (OPEN COLLECTOR)

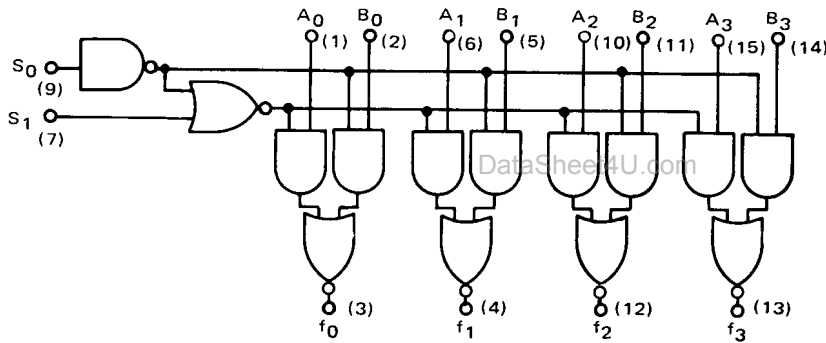

S <sub>0</sub>	S <sub>1</sub>	f <sub>n</sub>
0	0	$\overline{B}$
1	0	$\overline{A}$
0	1	$\overline{B}$
1	1	1

V<sub>CC</sub> = (16)  
 GND = (8)  
 ( ) = Denotes Pin Numbers

MC8235/MC7235 (OPEN COLLECTOR)

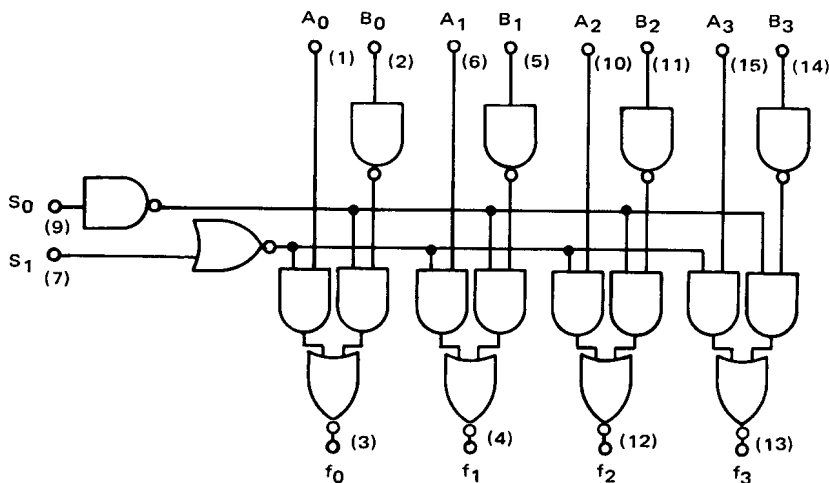

S <sub>0</sub>	S <sub>1</sub>	f <sub>n</sub>
0	0	$\overline{A_n}B_n$
0	1	$\overline{B_n}$
1	0	$\overline{A_n}$
1	1	1

V<sub>CC</sub> = (16)  
 GND = (8)  
 ( ) = Denotes Pin Numbers

MC8341 QUAD EXCLUSIVE OR • MC8242 QUAD EXCLUSIVE NOR

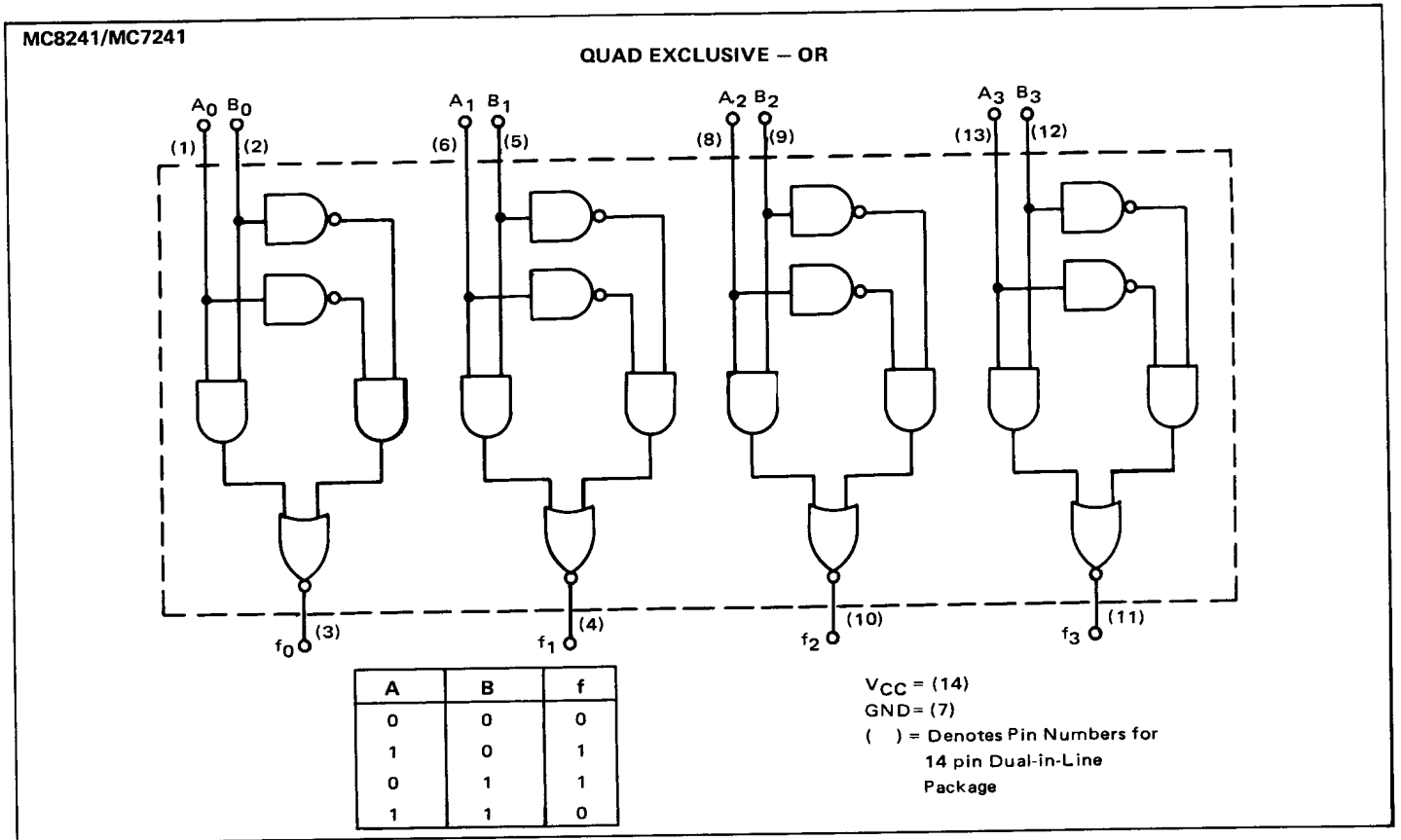

et4U.com

DataSheet4U.com

DataShe

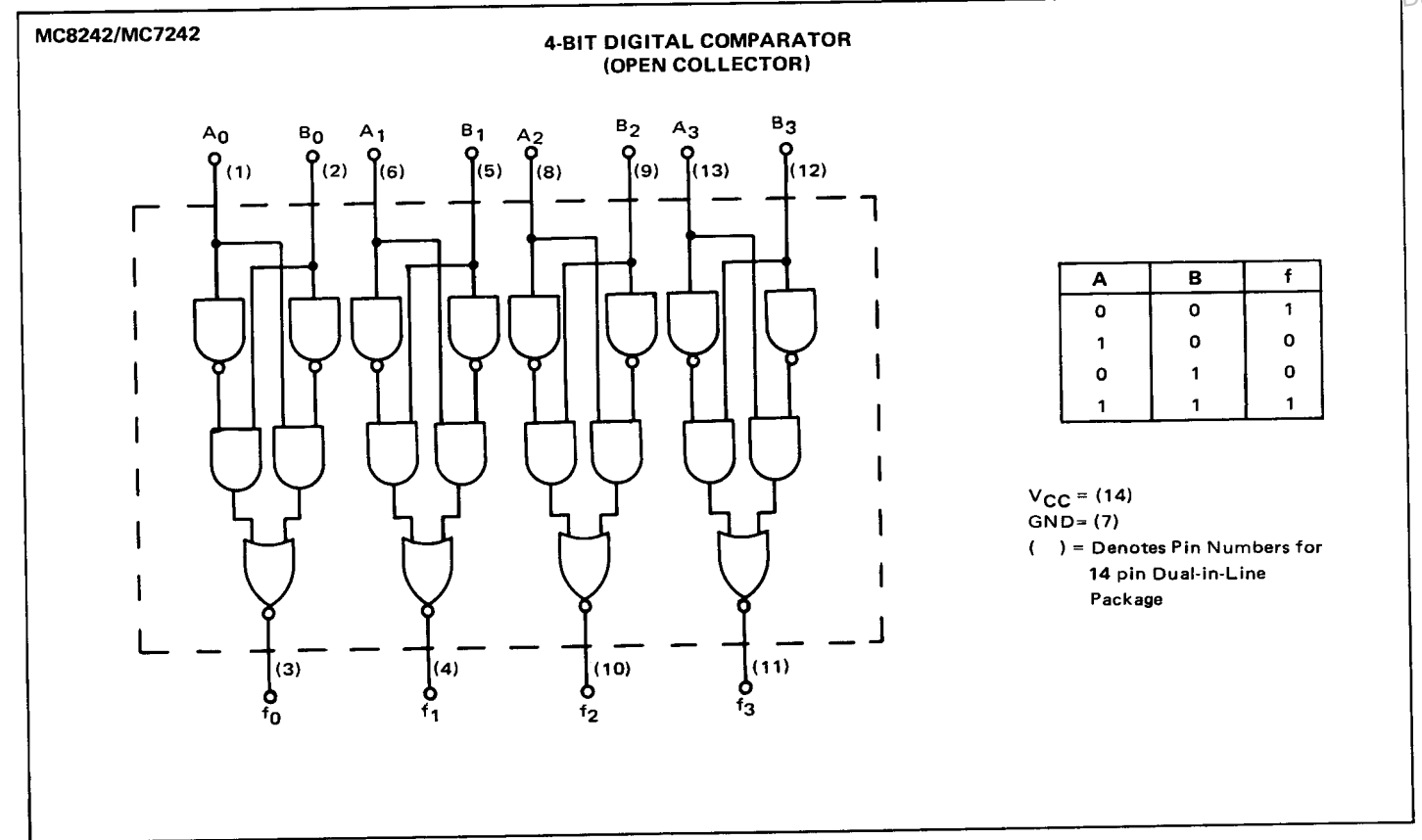

MC8250 BINARY TO ONE-OF-EIGHT DECODER • MC8251 BINARY TO ONE-OF-TEN DECODER

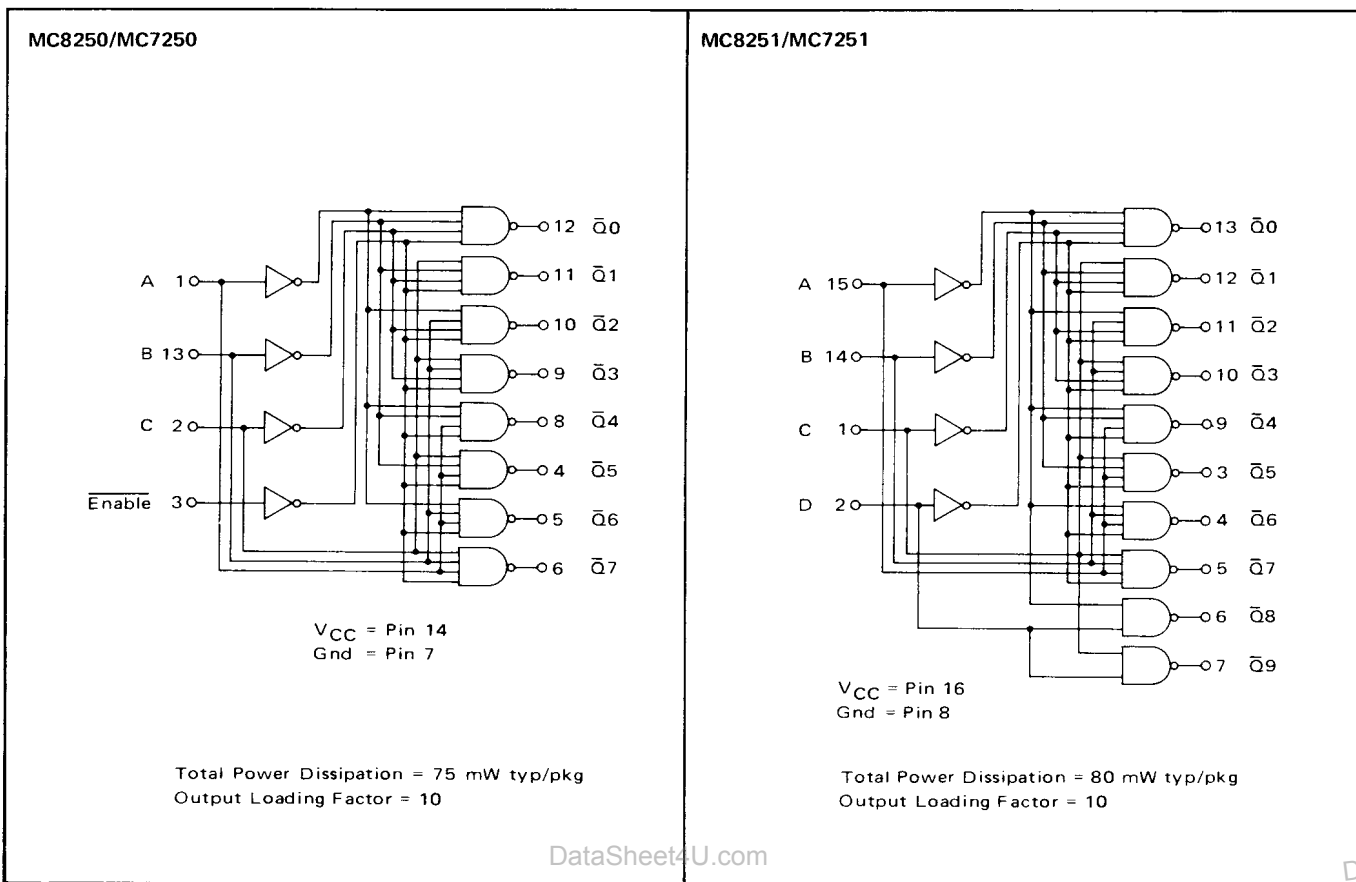

BOTH TYPES INPUT				MC8250/MC7250 OUTPUT								MC8251/MC7251 OUTPUT									
E/D	C	B	A	7	6	5	4	3	2	1	0	9	8	7	6	5	4	3	2	1	0
0	0	0	0	1	1	1	1	1	1	1	0	1	1	1	1	1	1	1	1	1	0
0	0	0	1	1	1	1	1	1	1	0	1	1	1	1	1	1	1	1	1	0	1
0	0	1	0	1	1	1	1	1	0	1	1	1	1	1	1	1	1	1	0	1	1
0	0	1	1	1	1	1	0	1	1	1	1	1	1	1	1	0	1	1	1	1	1
0	1	0	0	1	1	1	0	1	1	1	1	1	1	1	1	0	1	1	1	1	1
0	1	0	1	1	1	0	1	1	1	1	1	1	1	1	0	1	1	1	1	1	1
0	1	1	0	1	1	1	1	1	1	1	1	1	1	1	1	1	1	0	1	1	1
0	1	1	1	1	0	1	1	1	1	1	1	1	1	0	1	1	1	1	1	1	1
1	0	0	0	1	1	1	1	1	1	1	1	1	0	1	1	1	1	1	1	1	1
1	0	0	1	1	1	1	1	1	1	1	1	0	1	1	1	1	1	1	1	1	1
1	0	1	0	1	1	1	1	1	1	1	1	1	0	1	1	1	1	1	1	1	1
1	0	1	1	1	1	1	1	1	1	1	1	0	1	1	1	1	1	1	1	1	1
1	1	0	0	1	1	1	1	1	1	1	1	1	0	1	1	1	1	1	1	1	1
1	1	0	1	1	1	1	1	1	1	1	1	0	1	1	1	1	1	1	1	1	1
1	1	1	0	1	1	1	1	1	1	1	1	1	0	1	1	1	1	1	1	1	1
1	1	1	1	1	1	1	1	1	1	1	1	1	0	1	1	1	1	1	1	1	1

# MC8260 ARITHMETIC LOGIC ELEMENT • MC8261 FAST CARRY EXTENDER

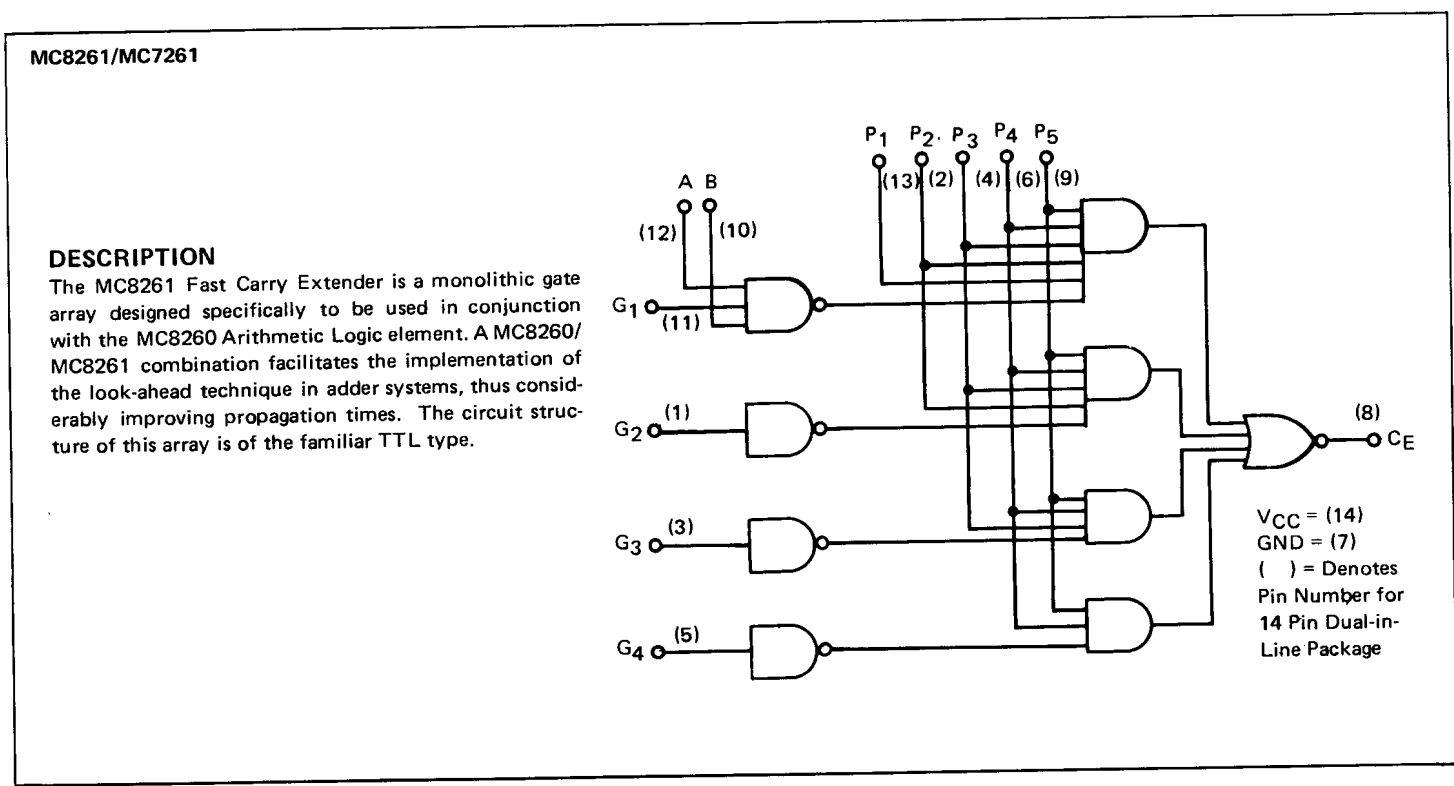
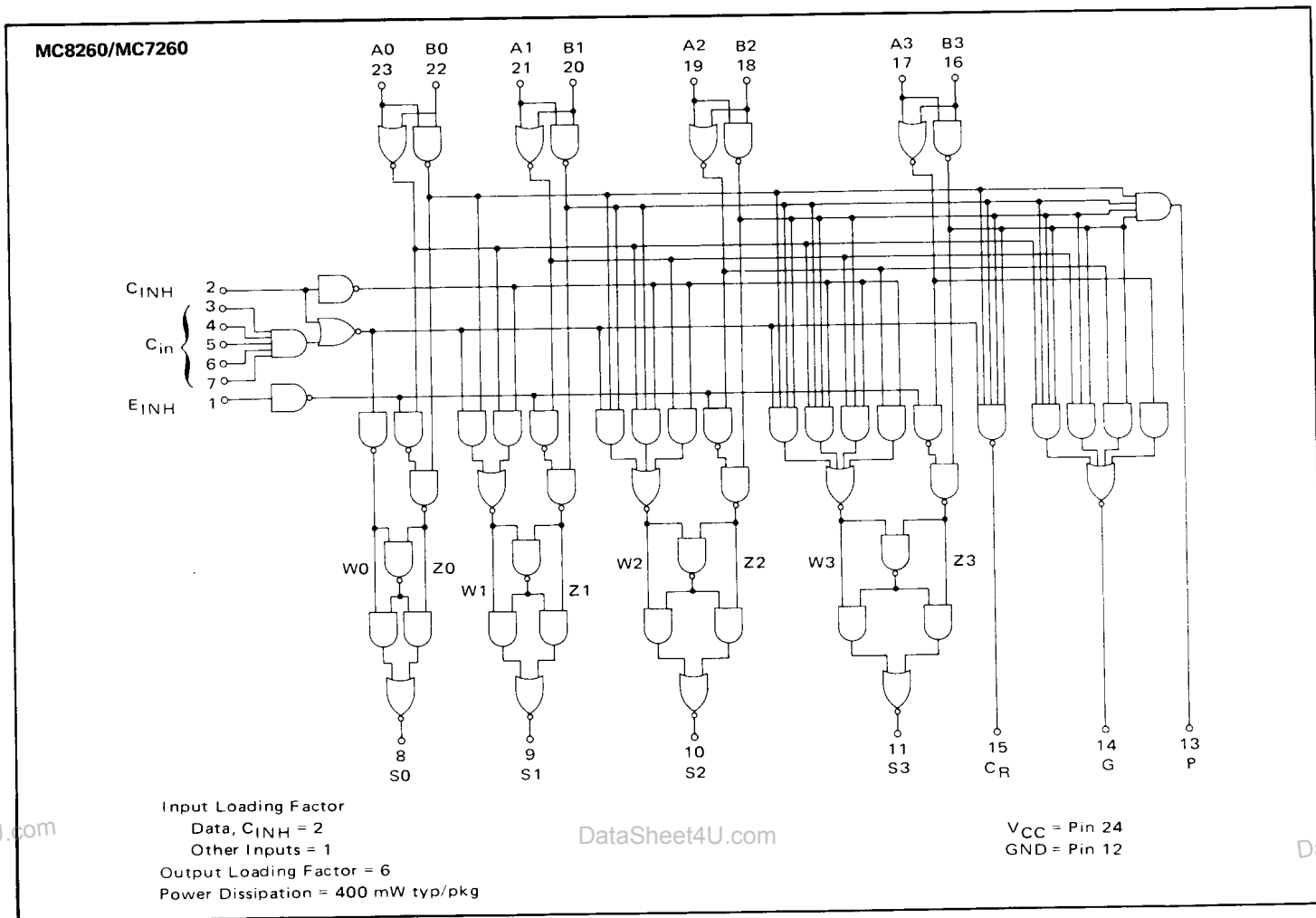

**MC8266 2-INPUT, 4-BIT DATA SELECTOR • MC8267 2-INPUT, 4-BIT DATA SELECTOR**  
**MC8270 • MC8271 4-BIT SHIFT REGISTERS**

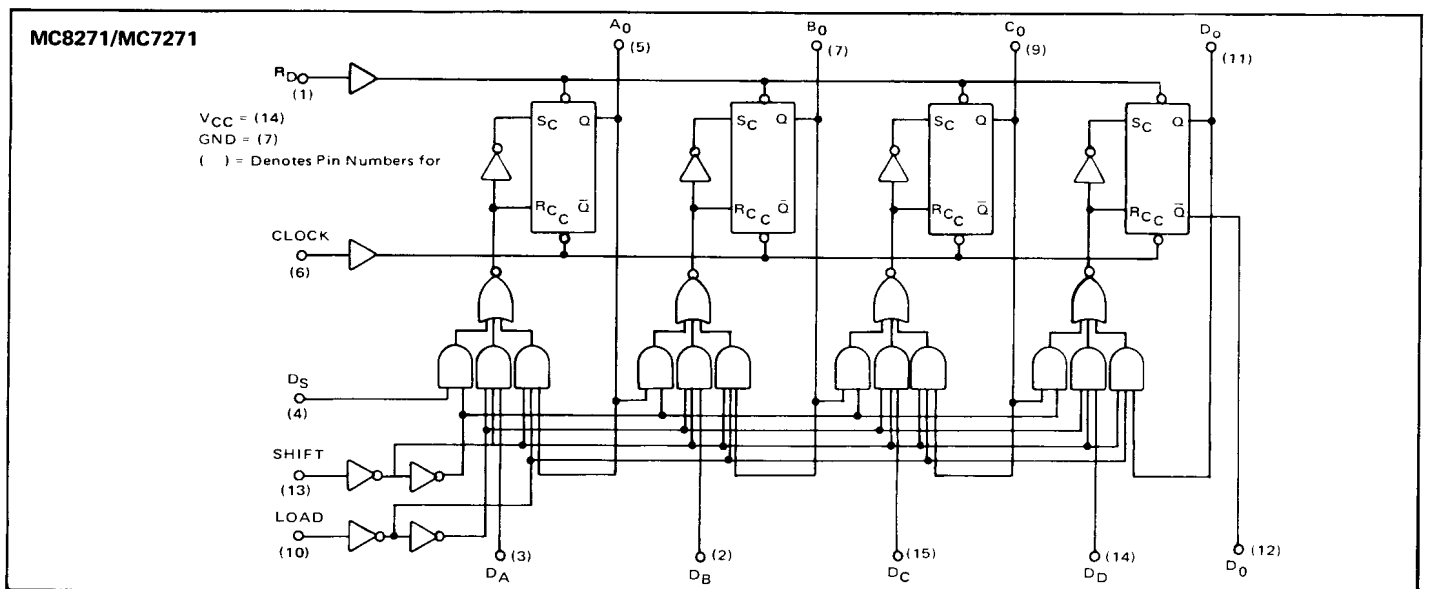
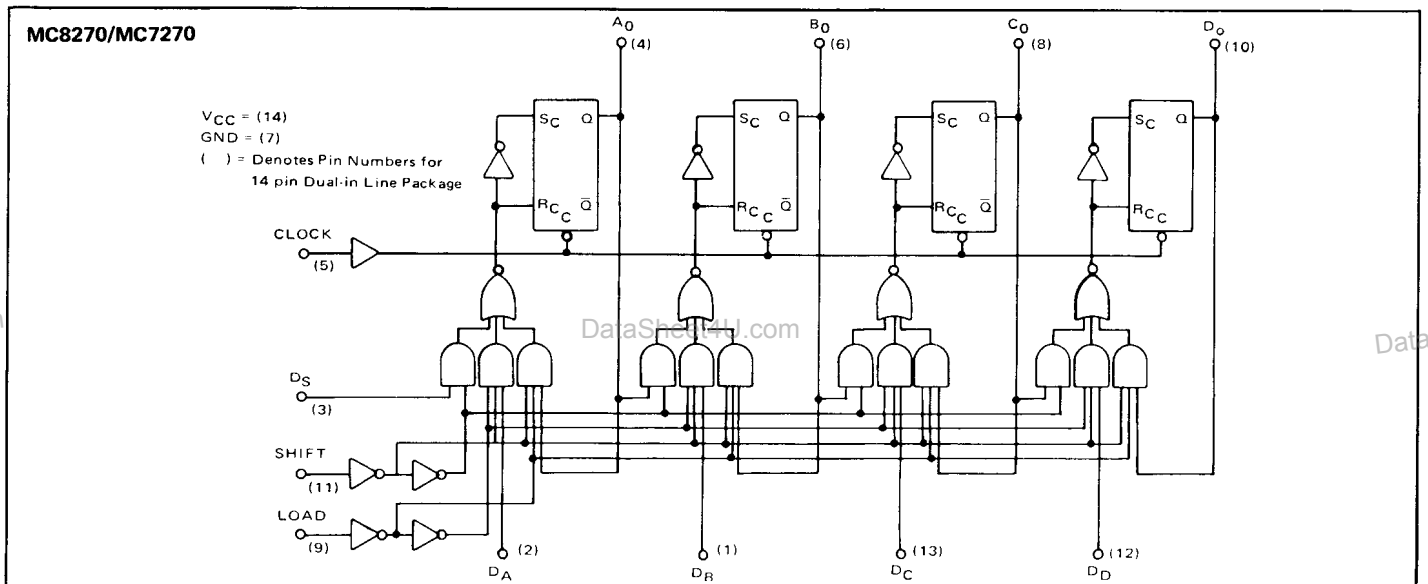
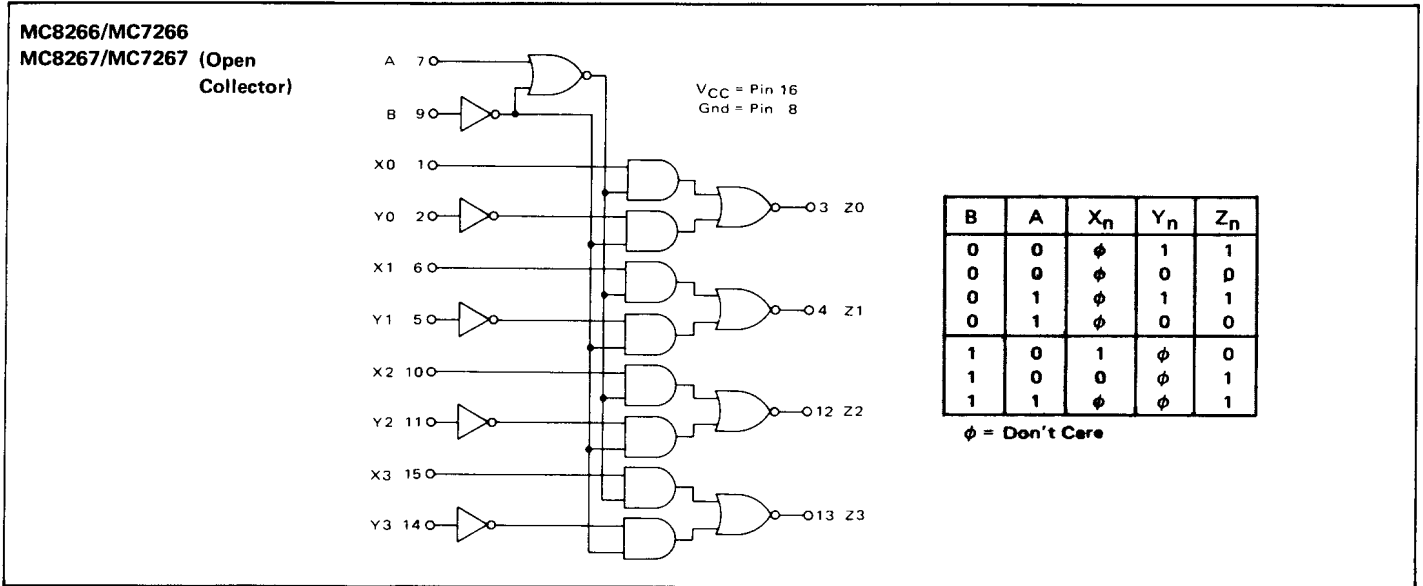

# MC8280 PRESETTABLE DECADE COUNTER • MC8281 PRESETTABLE BINARY COUNTER

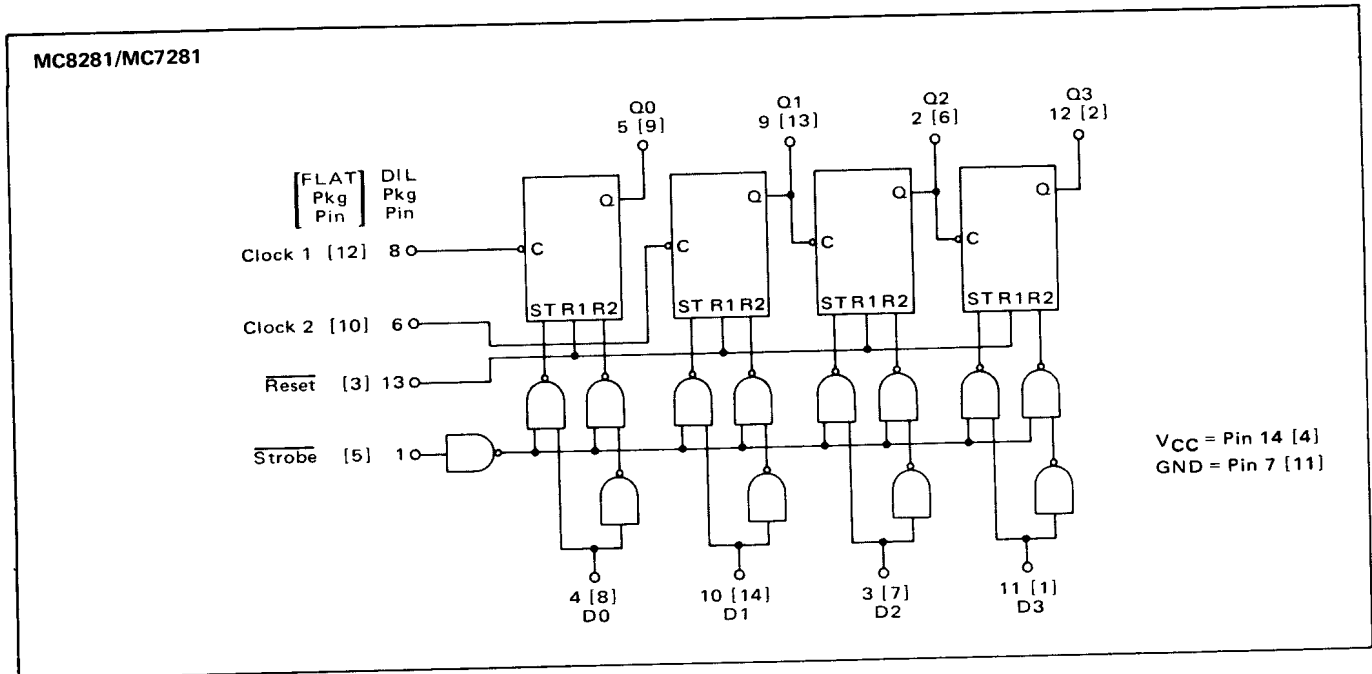
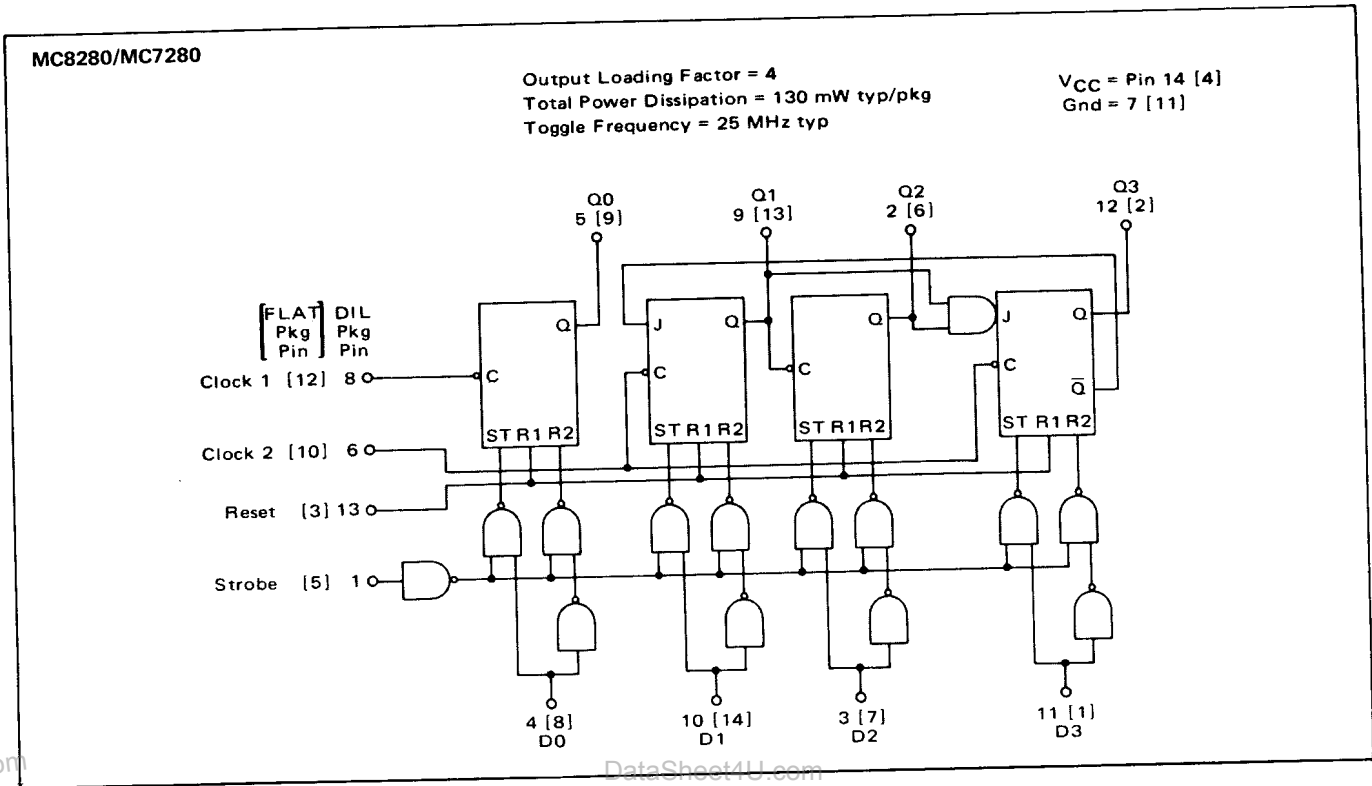



**MC8284 • MC8285 BINARY HEXADECIMAL AND BCD DECADE, SYNCHRONOUS UP/DOWN COUNTERS**

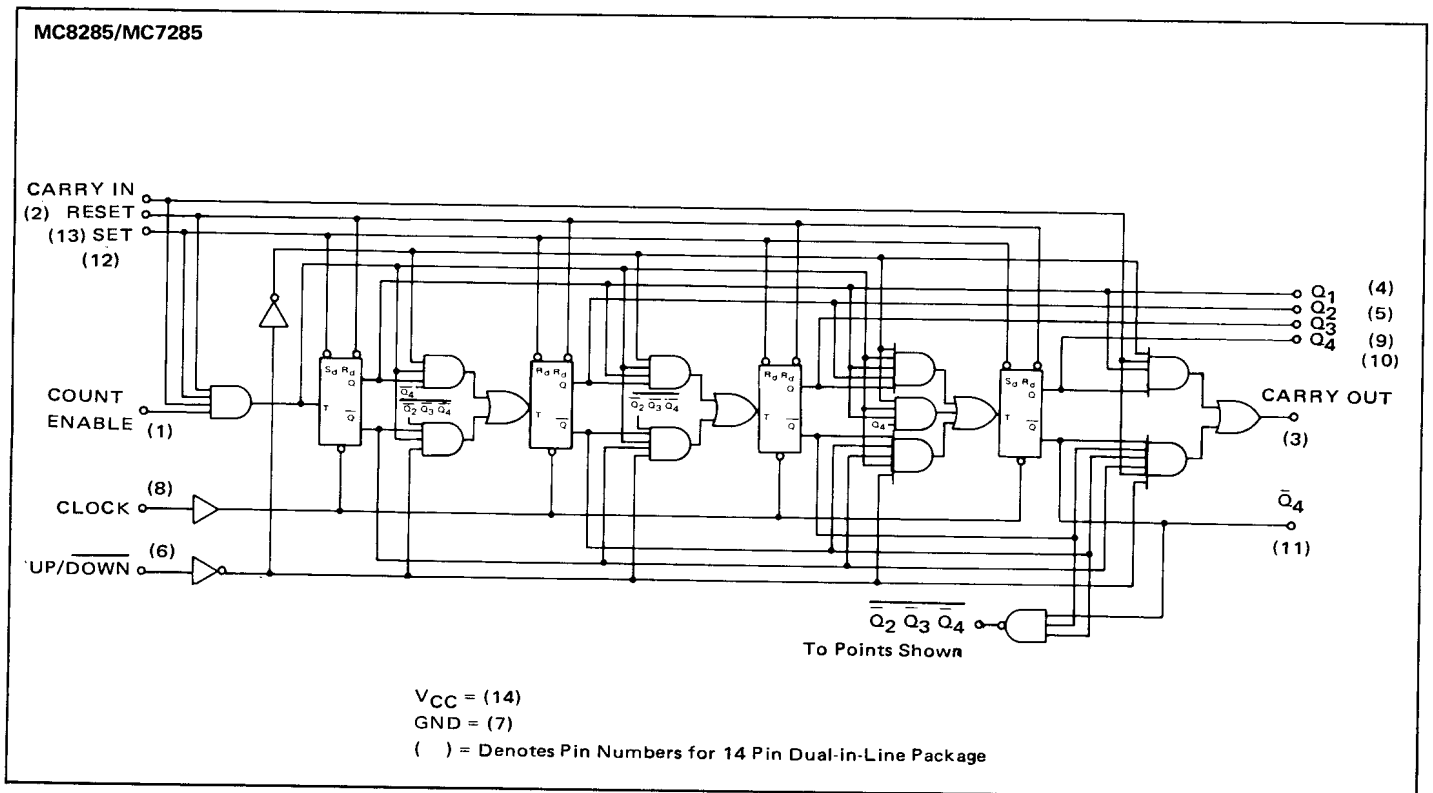
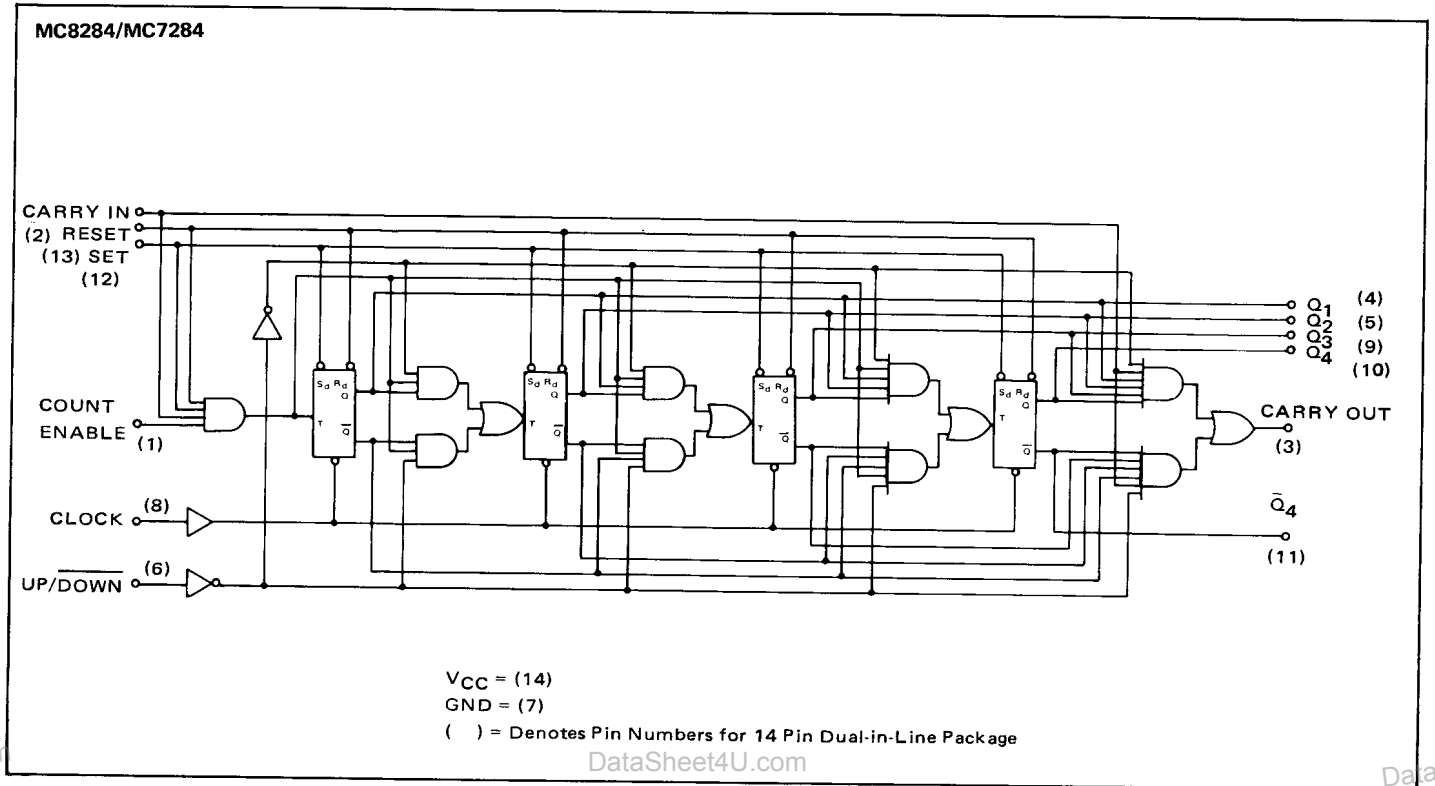

# MC8288 DIVIDE-BY-TWELVE COUNTER/STORAGE ELEMENT

## MCM8290 • MC8291 PRESETTABLE HIGH SPEED • DECADE/BINARY COUNTER

MC8288/MC7288

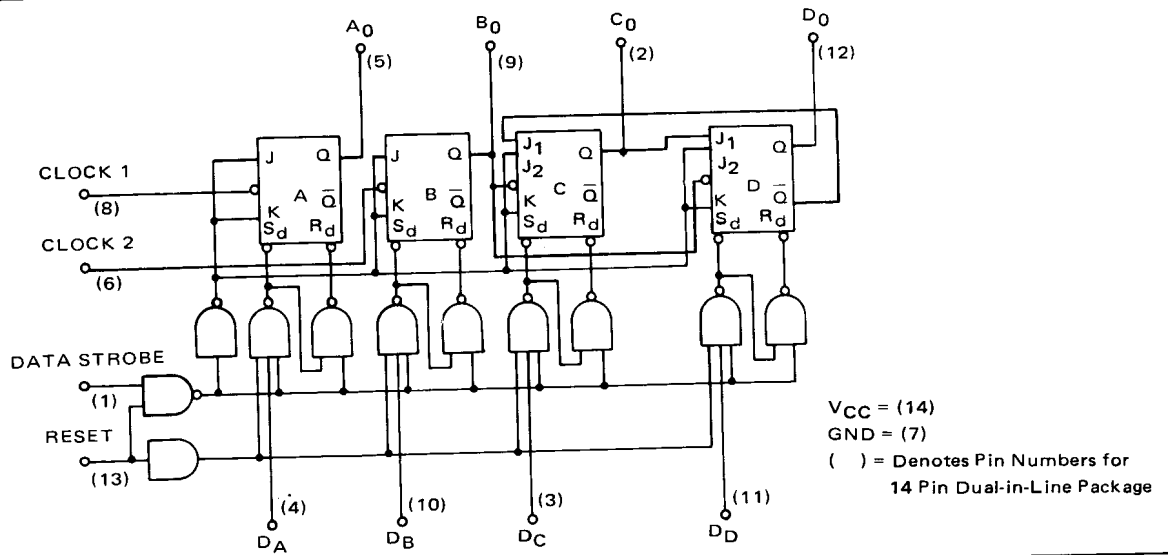

MC8290/MC7290

V<sub>CC</sub> = (14)  
GND = (7)  
( ) = Denotes Pin Numbers for 14 Pin Dual-in-Line Package

Input	B <sub>0</sub>	C <sub>0</sub>	D <sub>0</sub>	A <sub>0</sub>
0	0	0	0	0
1	1	0	0	0
2	0	1	0	0
3	1	1	0	0
4	0	0	0	1
5	0	0	0	1
6	1	0	0	1
7	0	1	0	1
8	1	1	0	1
9	0	0	1	1

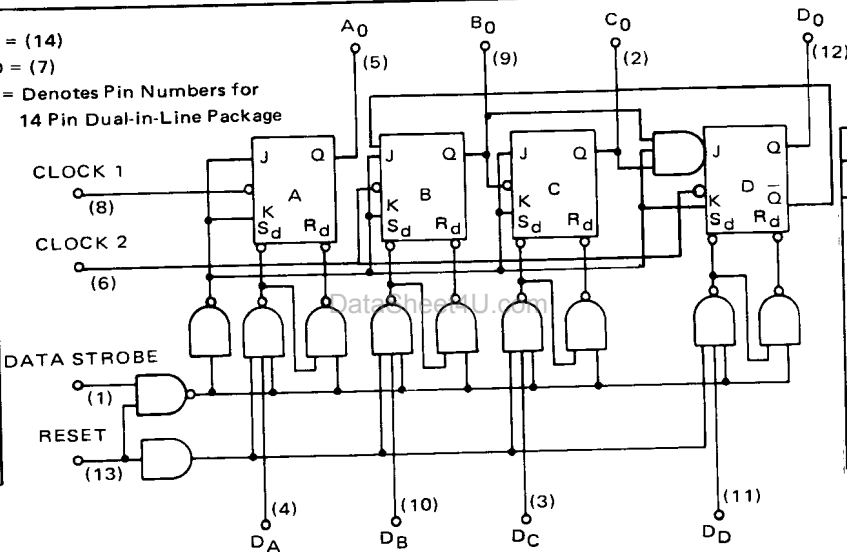

Input	A <sub>0</sub>	B <sub>0</sub>	C <sub>0</sub>	D <sub>0</sub>
0	0	0	0	0
1	1	0	0	0
2	0	1	0	0
3	1	1	0	0
4	0	0	1	0
5	1	0	1	0
6	0	1	1	0
7	1	1	1	0
8	0	0	0	1
9	1	0	0	1

MC8291/MC7291

V<sub>CC</sub> = (14)  
GND = (7)  
( ) = Denotes Pin Numbers for 14 Pin Dual-in-Line Package

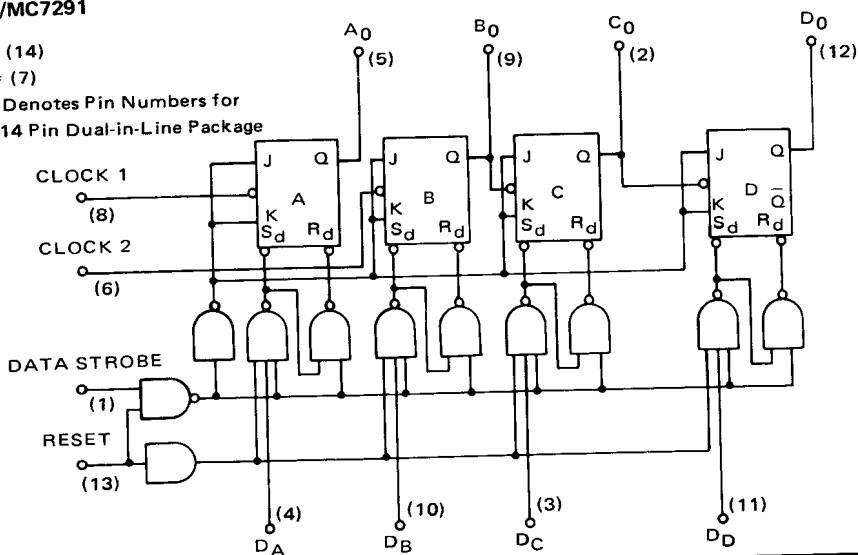

Input	A <sub>0</sub>	B <sub>0</sub>	C <sub>0</sub>	D <sub>0</sub>
0	0	0	0	0
1	1	0	0	0
2	0	1	0	0
3	1	1	0	0
4	0	0	1	0
5	1	0	1	0
6	0	1	1	0
7	1	1	1	0
8	0	0	0	1
9	1	0	0	1
10	0	1	0	1
11	1	1	0	1
12	0	0	1	1
13	1	0	1	1
14	0	1	1	1
15	1	1	1	1