CMOS single-chip 8-bit MCU with 12-bit A/D converter and LCD Driver



MC96F6632S **User's manual**

V 1.1

Main features

- **8-bit Microcontroller With High Speed 8051 CPU**
- **Basic MCU Function**
 - 32Kbytes Flash Code Memory
 - 1280bytes SRAM
- **Built-in Analog Function**
 - Power-On Reset and Low Voltage Detect Reset
 - Internal 8MHz RC Oscillator ($\pm 3.5\%$, $T_A = -40^\circ\text{C} \sim +85^\circ\text{C}$)
 - Watchdog Timer RC Oscillator (5kHz)
- **Peripheral Features**
 - 12-bit Analog to Digital Converter (5 inputs)
 - USART, SIO
 - LCD Driver (24Segment x 8Common)
- **I/O and Packages**
 - Up to 54 Programmable I/O lines with 64QFP-1010
- **Operating Conditions**
 - 1.8 V to 5.5V Wide Voltage Range
 - -40°C to 85°C Temperature Range
- **Application**
 - Small Home Appliance
 - Thermostat

Revised 12 July, 2013

Revision history

Version	Date	Revision list
0.0	2013.02.19	Published this book.
1.0	2013.05.23	Revised this book. Change "100,000" to "10,000(Sector 0~507)/100,000(Sector 508~511)" in Flash endurance.
1.1	2013.07.12	Revised this book. Add a Programmer Type "PGMplusLC Writer". Fixed a typo.

Version 1.1

Published by FAE team

2013 ABOV Semiconductor Co. Ltd. all rights reserved.

Additional information of this manual may be served by ABOV Semiconductor offices in Korea or distributors.

ABOV Semiconductor reserves the right to make changes to any information here in at any time without notice.

The information, diagrams and other data in this manual are correct and reliable;

however, ABOV Semiconductor is in no way responsible for any violations of patents or other rights of the third party generated by the use of this manual.

1 Overview

1.1. Description

The MC96F6632S is an advanced CMOS 8-bit microcontroller with 32Kbytes of FLASH memory. This is powerful microcontroller which provides a highly flexible and cost effective solution to many embedded control applications. This provides the following features : 32Kbytes of FLASH, 256bytes of IRAM, 1Kbytes of XRAM , general purpose I/O, basic interval timer, watchdog timer, 8/16-bit timer/counter, carrier generation, 8/16-bit PWM output, watch timer, buzzer driving port, SIO, UART, 12-bit A/D converter, LCD driver, on-chip POR, LVR, LVI, on-chip oscillator and clock circuitry. The MC96F6632S also supports power saving modes to reduce power consumption.

Device Name	FLASH	XRAM	IRAM	ADC	I/O PORT	Package
MC96F6632SL	32Kbytes	1Kbytes	256 bytes	5 channels	54	64LQFP

Table 1-1. Ordering Information of MC96F6632S

1.2 Features

- **CPU**
 - 8-Bit CISC Core (M8051 2clocks per cycle)
- **ROM (FLASH) Capacity**
 - 32Kbytes
 - Flash with self-read/write capability
 - In-system programming (ISP)
 - Endurance : 10,000 times(Sector 0 ~ 507)
100,000 times(Sector 508 ~ 511)
- **256bytes IRAM**
- **1Kbytes XRAM**
 - (30bytes including LCD display RAM)
- **General Purpose I/O (GPIO)**
 - Normal I/O : 18 Ports
(P0[5:0], P1[2:0], P1[6:4], P2[4:0], P92)
 - LCD shared I/O : 36 Ports
(P3[6:1], P4, P5, P6, P7[4:2], P8[7:5])
- **Basic Interval Timer (BIT)**
 - 8-bit x 1-ch
- **Watch Dog Timer (WDT)**
 - 8-bit x 1-ch
 - 5kHz internal RC oscillator
- **Timer/ Counter**
 - 8-bit x 2-ch (T0/T1), 16-bit x 2-ch (T2/T3)
- **Carrier Generation**
 - Carrier Generation (by T1), T2 Clock source
- **PWM**
 - 8-bit x 1-ch (by T0), 16-bit x 1-ch (by T3)
- **Watch Timer (WT)**
 - 3.91ms/0.25s/0.5s/1s/1minute interval at 32.768kHz
- **Buzzer**
 - 8-bit x 1-ch
- **SIO**
 - 8-bit x 1-ch
- **UART**
 - 8-bit x 1-ch
- **12-Bit A/D Converter**
 - 5 Input channels
- **LCD Driver**
 - 24Segments and 8Common terminals
 - Internal or external resistor bias
 - 2, 3, 4, 5, 6 and 8 common selectable
 - Bias selectable (1/2, 1/3, 1/4)
- **Power On Reset**
 - Reset release level (1.4V)
- **Low Voltage Reset**
 - 14 level detect (1.60V/ 2.00V/ 2.10V/ 2.20V/ 2.32V/
2.44V/ 2.59V/ 2.75V/ 2.93V/ 3.14V/ 3.38V/ 3.67V/
4.00V/ 4.40V)
- **Low Voltage Indicator**
 - 13 level detect (2.00V/ 2.10V/ 2.20V/ 2.32V/ 2.44V/
2.59V/ 2.75V/ 2.93V/ 3.14V/ 3.38V/ 3.67V/ 4.00V/
4.40V)
 - External reference detect
- **Interrupt Sources**
 - External Interrupts
(EXINT0~5, EINT10, EINT13) (8)
 - Timer(0/1/2/3) (6)
 - WDT (1)
 - BIT (1)
 - WT (1)
 - SIO (1)
 - UART(TX/RX) (2)
 - ADC (1)
- **Internal RC Oscillator**
 - Internal RC frequency: 8MHz \pm 3.5%
($T_A = -40^{\circ}\text{C} \sim +85^{\circ}\text{C}$)
- **Power Down Mode**
 - STOP, IDLE mode
- **Operating Voltage and Frequency**
 - 1.8V ~ 5.5V (@1.0 ~ 4.2MHz)
 - 2.7V ~ 5.5V (@1.0 ~ 10.0MHz)
 - 3.0V ~ 5.5V (@1.0 ~ 12.0MHz)
- **Minimum Instruction Execution Time**
 - 167ns (@ 12MHz main clock)
 - 61us (@ 32.768kHz sub clock)
- **Operating Temperature: – 40 ~ + 85 °C**
- **Oscillator Type**
 - 1.0-12.0MHz Crystal or Ceramic for main clock
 - 32.768kHz Crystal for sub clock
- **Package Type**
 - 64 LQFP-1010

1.3 Development tools

1.3.1 Compiler

ABOV Semiconductor does not provide compiler. It is recommended that you consult a compiler provider. The MC96F6632S core is Mentor 8051, and the ROM size is smaller than 64Kbytes. Therefore, developer can use the standard 8051 compiler from other providers.

1.3.2 OCD(On-chip debugger) emulator and debugger

The OCD (On Chip Debug) emulator supports ABOV Semiconductor's 8051 series MCU emulation. The OCD interface uses two-wire connection between PC and MCU which is attached to user's system. The OCD can read or change the value of MCU internal memory and I/O peripherals. And the OCD also controls MCU internal debugging logic, it means OCD controls emulation, step run, monitoring, etc.

The OCD debugger program works on Microsoft-Windows NT, 2000, XP, Vista (32-bit) operating system. If you want to see more details, please refer to OCD debugger manual. You can download debugger SW and manual from our website (<http://www.abov.co.kr>).

Connection:

- DSCL (MC96F6832 P01 port)
- DSDA (MC96F6832 P00 port)

NOTE)

1. MC96F6632S does not support the OCD function. MC96F6832 should be used for debugging.

OCD connector diagram: Connect OCD with user system

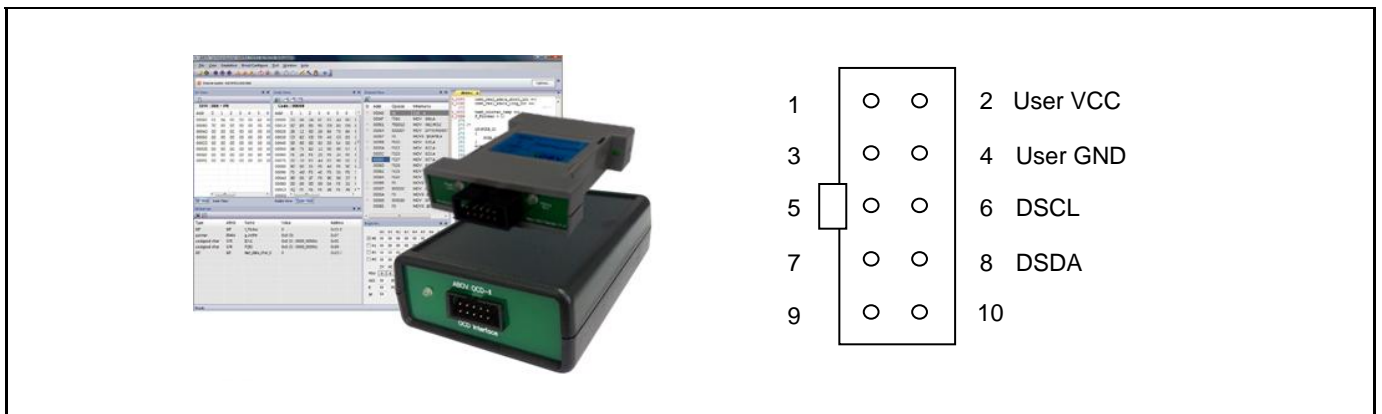

Figure 1-1. Debugger and pin description

Subject	MC96F6632S (Not used: always "0b")	MC96F6832 (Evaluation Chip) (Parenthesis: Reset Values)
P06 – P07 Related Registers (Chapter 9.3 – P0 Port)	1. Bits 7-6 of P0/P0IO/P0PU/P0OD/P0DB Registers: "Not used"	1. Bits 7-6 of P0/P0IO/P0PU/P0OD/P0DB Registers: "Used (11b)"
P13 and P75 Related Registers (Chapter 9.4 – P1 Port)	1. Bit 3 of P1/P1IO/P1PU/P1OD Registers: "Not used" 2. Bit 4 of P1DB Register: "Not used" 3. Bits 4-3 of PFSR0 Register: "Not used"	1. Bit 3 of P1/P1IO/P1PU/P1OD Registers: "Used (1b)" 2. Bit 4 of P1DB Register: "Used (0b)" 3. Bits 4-3 of PFSR0 Register: "Used (00b)"
P25 – P27 Related Registers (Chapter 9.5 – P2 Port)	1. Bits 7-5 of P2/P2IO/P2PU/P2OD Registers : "Not used" 2. Bits 7-6 of PFSR1 Register: "Not used" 3. Bits 1-0 of PFSR2 Register: "Not used"	1. Bits 7-5 of P2/P2IO/P2PU/P2OD Registers: "Used (111b)" 2. Bits 7-6 of PFSR1 Register: "Used (00b)" 3. Bits 1-0 of PFSR2 Register: "Used (00b)"
P77 – P75 and P71 – P70 Related Registers (Chapter 9.10 – P7 Port)	1. Bits 7-5 and 1-0 of P7/P7IO/P7PU/P7OD Registers: "Not used" 2. Bit 7 of P9CDR Register: "Not used" 3. Bits 5-4 of PFSR5 Register: "Not used" 4. Bits 7-4 of PFSR6 Register: "Not used" 5. Bits 1-0 of PFSR7 Register: "Not used"	1. Bits 7-5 and 1-0 of P7/P7IO/P7PU/P7OD Registers: "Used (000b and 00b)" 2. Bit 7 of P9CDR Register: EINT10 Position Select 3. Bits 5-4 of PFSR5 Register: "Used (00b)" 4. Bits 7-4 of PFSR6 Register : "Used (0000b)" 5. Bits 1-0 of PFSR7 Register: "Used (00b)"
P84 – P80 Related Registers (Chapter 9.11 – P8 Port)	1. Bits 4-0 of P8/P8IO/P8PU/P8OD Registers : "Not used" 2. Bits 7-2 of PFSR7 Register: "Not used" 3. Bits 1-0 of PFSR8 Register: "Not used"	1. Bits 4-0 of P8/P8IO/P8PU/P8OD Registers: "Used (11111b)" 2. Bits 7-2 of PFSR7 Register : "Used (000000b)" 3. Bits 1-0 of PFSR8 Register: "Used (00b)"
EINT7 – 6 Related Registers (Chapter 10.2 – Ext. Interrupt)	1. Bits 7-6 of EIFLAG0/EIEDGE0/EIPOL0/EIENAB0 Registers: "Not used"	1. Bits 7-6 of EIFLAG0/EIEDGE0/EIPOL0/EIENAB0 Registers: "Not used"
LVIREF Pin Related Register (Chapter 13.8 – LVI)	1. Bit 3-0 of LVICR Register: "Not available" when the bits are "1101b"	1. Bit 3-0 of LVICR Register: LVIREF Pin when the bits are "1101b"
AN7 – AN5 Related Register (11.11 – 12bit A/D Converter	1. Bits 3-0 of ADCCRL Register: "0101b"/ "0110b"/"0111b": "Not available"	1. Bits 3-0 of ADCCRL Register: "0101b"/ "0110b"/"0111b": "Available"

Table 1-2. Difference between MC96F6632S and evaluation chip (MC96F6832)

1.3.3 Programmer

Single programmer:

PGMplus USB: It programs MCU device directly.

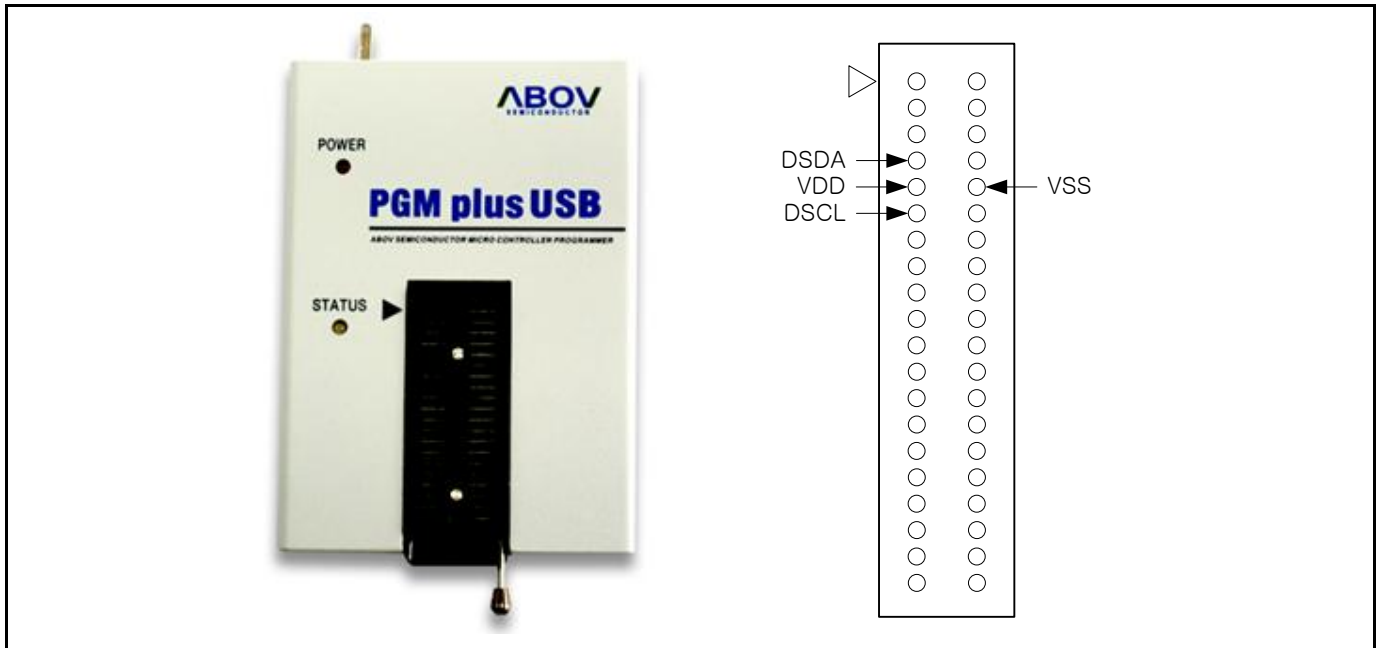

Figure 1-1. PGMplusUSB(Single writer)

Standalone PGMplus:

It programs MCU device directly.

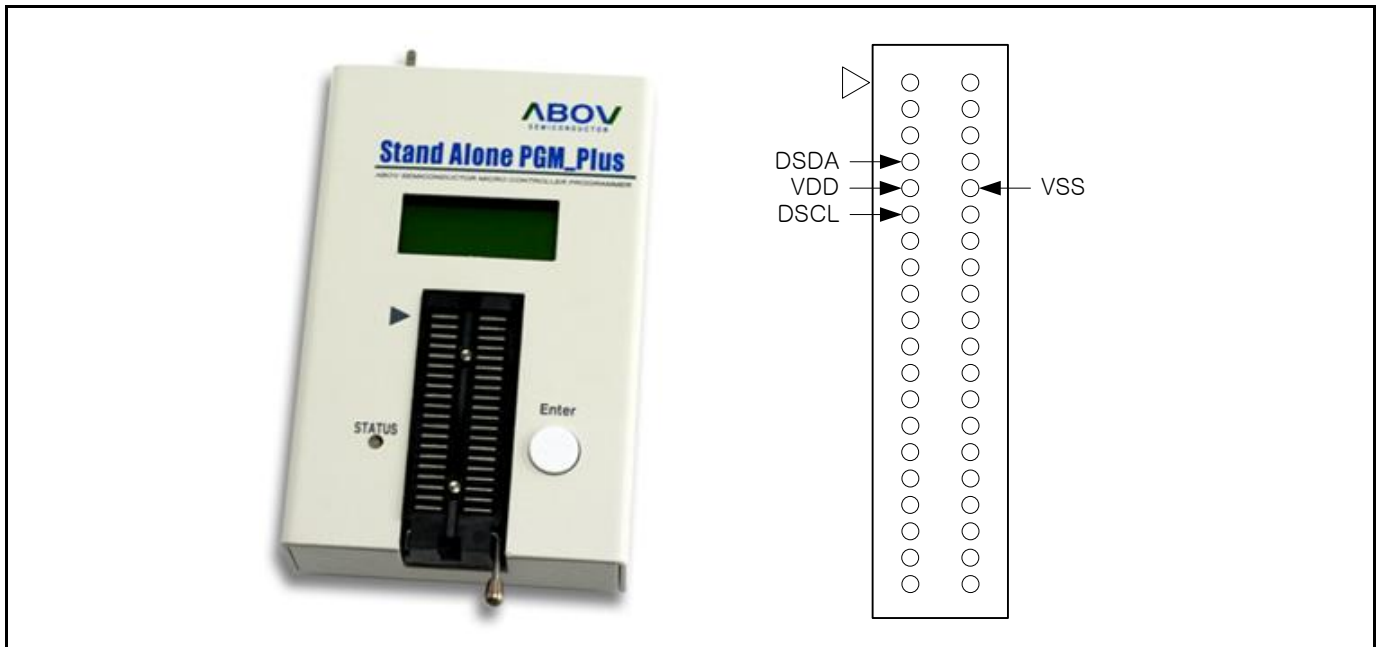

Figure 1-2. Standalone PGMplus(Single writer)

PGMplusLC Writer:

On Board Programming with PGMplusLC Writer available at MC9xFxxxxS main chip only, not available at OCD chip.

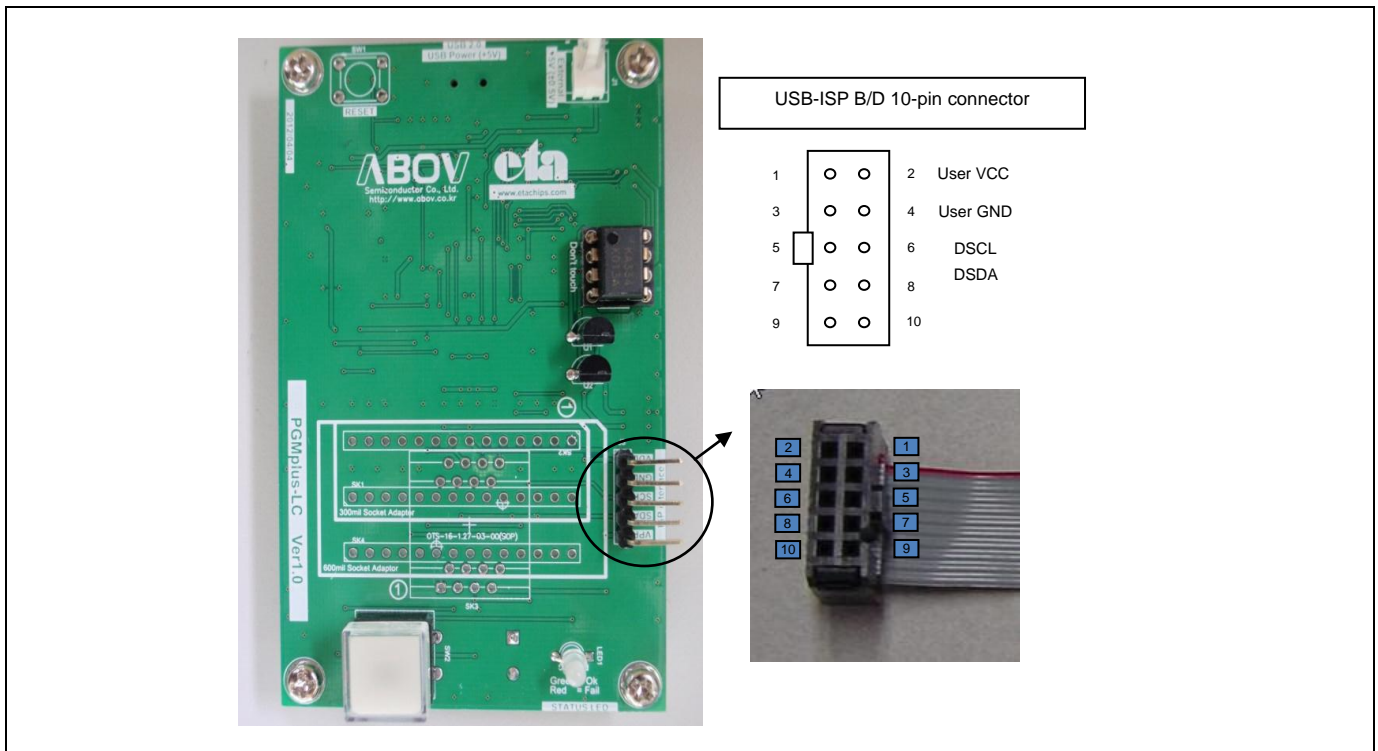

Figure 1-3. PGMplusLC writer

OCD emulator:

It can write code to MCU device too, because OCD debugger supports ISP (In System Programming).It does not require additional H/W, except developer's target system.

Gang programmer:

It programs 8 MCU devices at once. So, it is mainly used in mass production factory.

Gang programmer is standalone type, it means it does not require host PC, after a program is downloaded from host PC to Gang programmer.



Figure 1-4. Standalone Gang8 (for Mass Production)

1.4 MTP programming

1.4.1 Overview

The program memory of MC96F6632S is MTP Type. This flash is accessed by serial data format. There are four pins(DSCL, DSDA, VDD, and VSS) for programming/reading the flash.

Pin name	Main chip pin name	During programming	
		I/O	Description
DSCL	P01	I	Serial clock pin. Input only pin.
DSDA	P00	I/O	Serial data pin. Output port when reading and input port when programming. Can be assigned as input/push-pull output port.
VDD, VSS	VDD, VSS	-	Logic power supply pin.

Table 1-3. Descriptions of pins which are used to programming/reading the Flash

1.4.2 On-Board programming

The MC96F6632S needs only four signal lines including VDD and VSS pins for programming FLASH with serial communication protocol. Therefore the on-board programming is possible if the programming signal lines are ready at the PCB of application board is designed.

1.4.2.1 Circuit Design Guide

At the FLASH programming, the programming tool needs 4 signal lines that are DSCL, DSDA, VDD, and VSS. When you design the PCB circuits, you should consider the usage of these signal lines for the on-board programming.

Please be careful to design the related circuit of these signal pins because rising/falling timing of DSCL and DSDA is very important for proper programming.

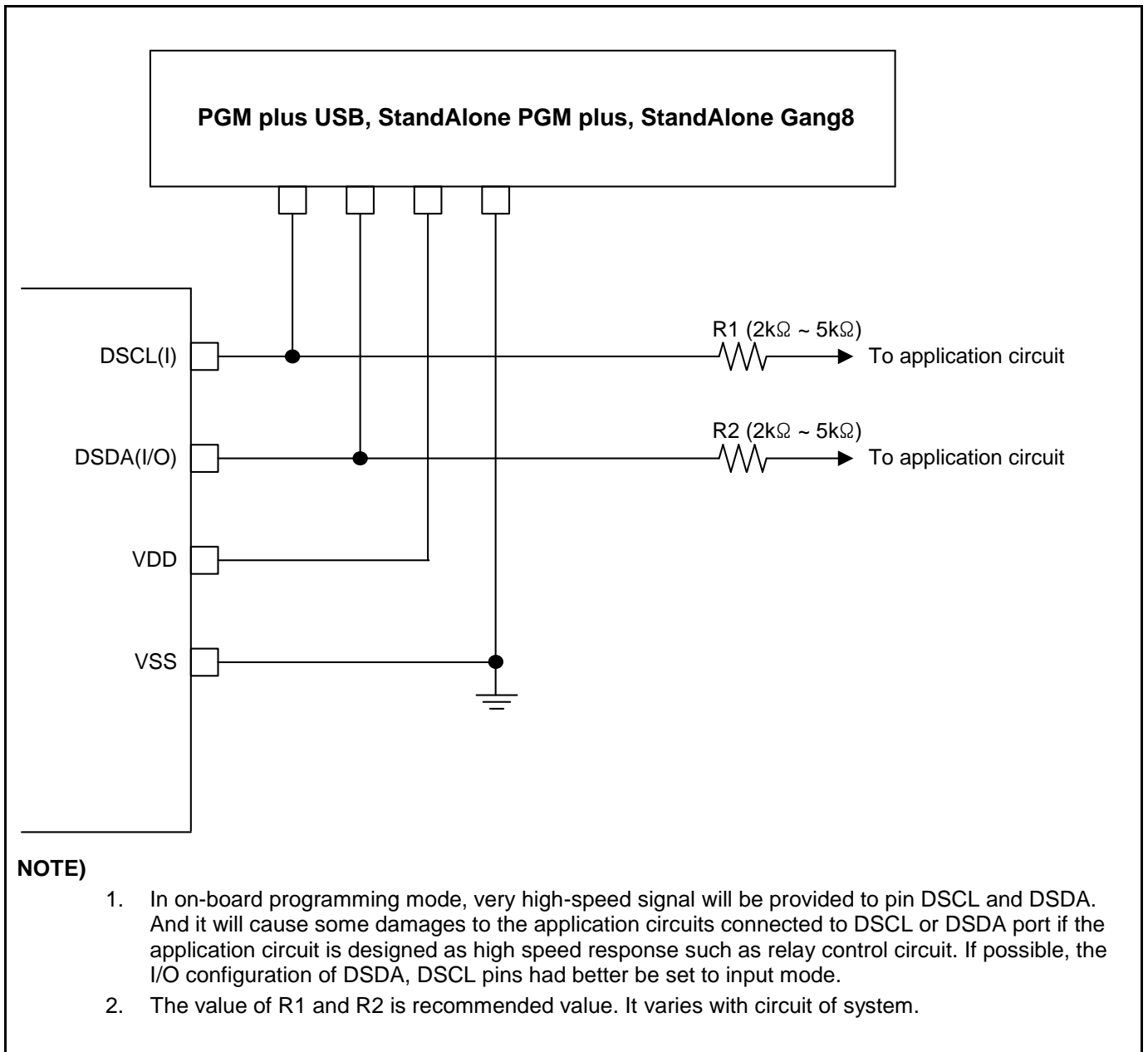

Figure 1-5. PCB design guide for on board programming

2 Block diagram

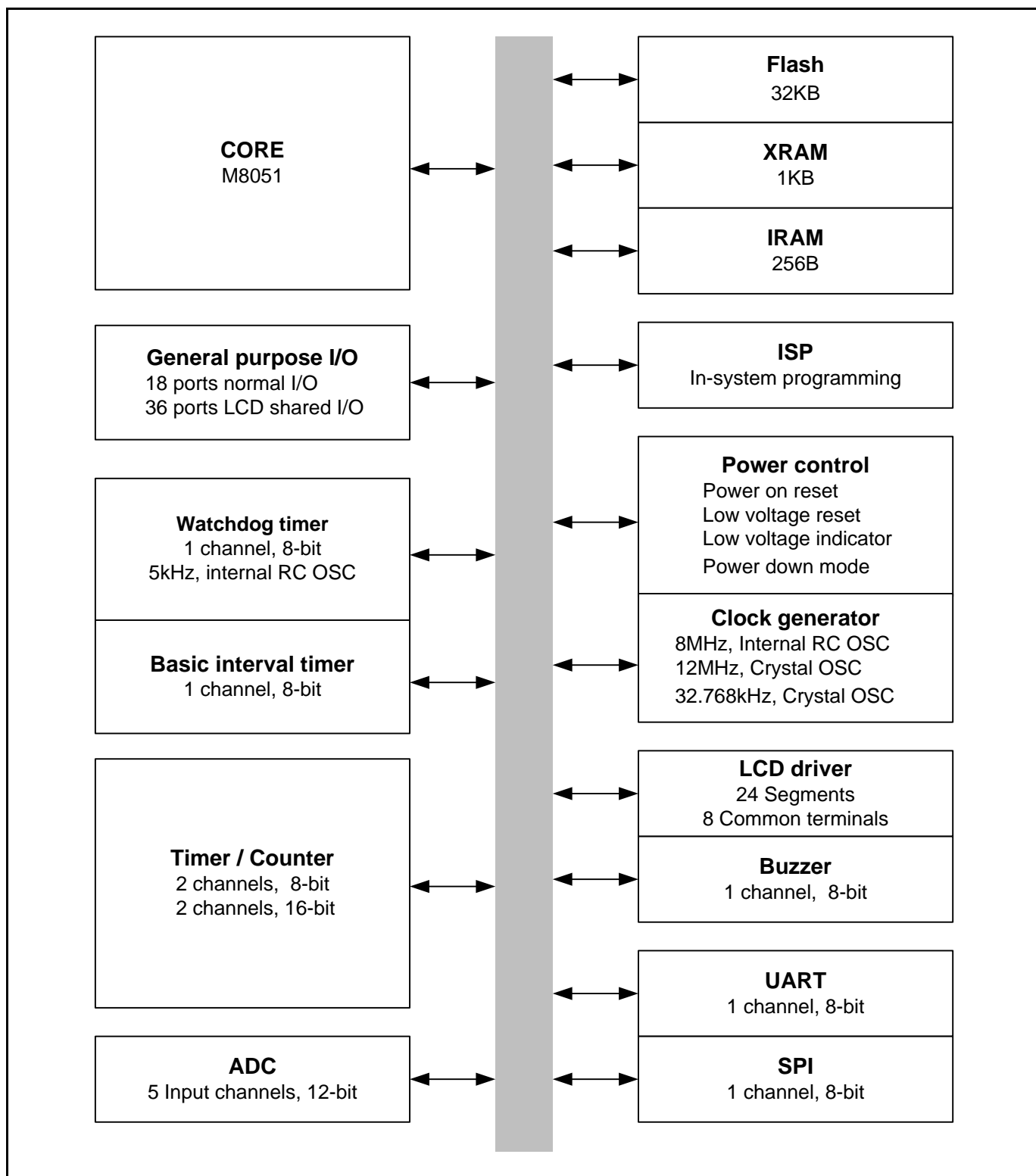
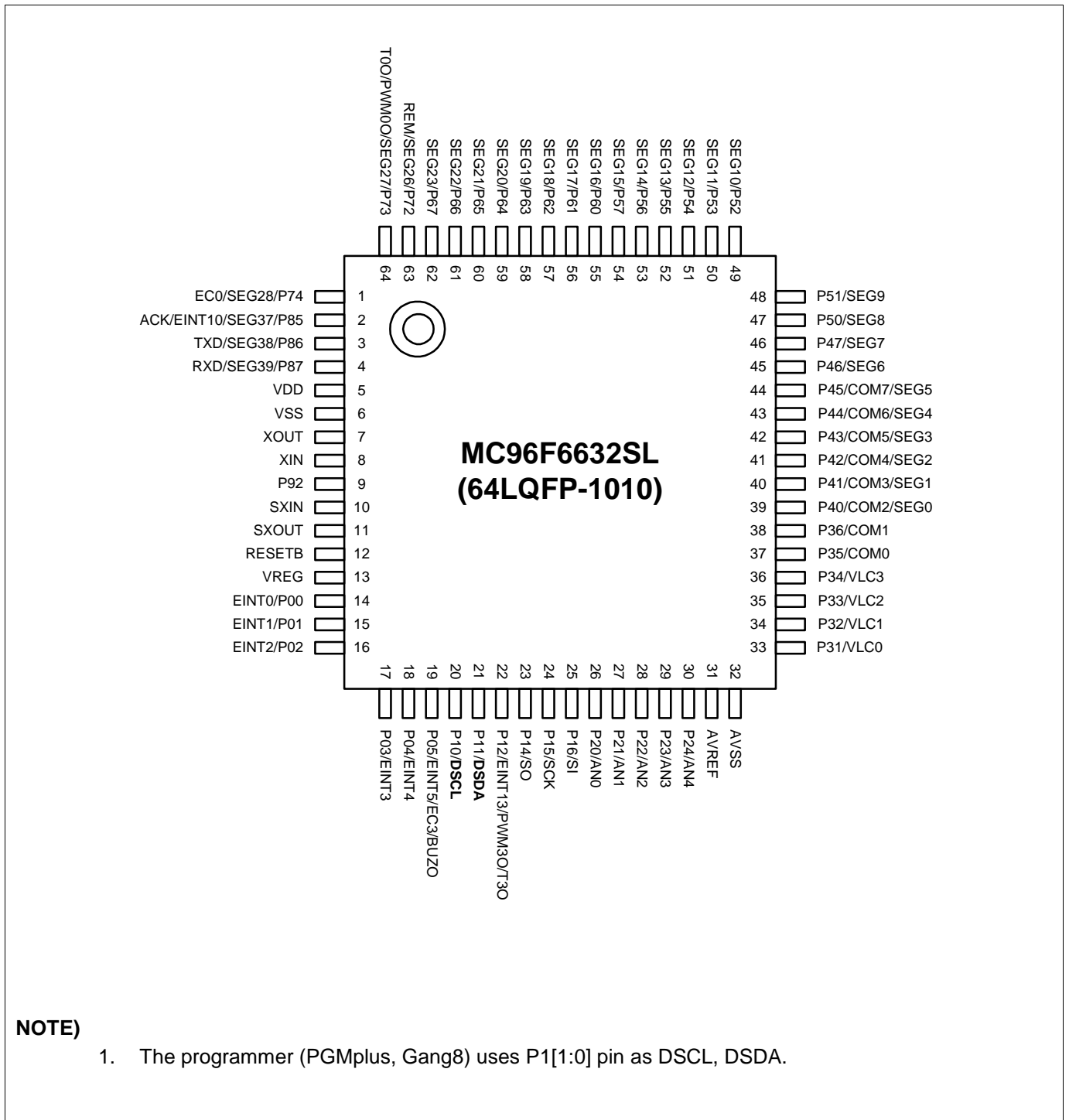

Figure 2-1. Block diagram of MC96F6632S

3 Pin assignment



NOTE)

1. The programmer (PGMplus, Gang8) uses P1[1:0] pin as DSCL, DSDA.

Figure 3-1. MC96F6632SL 64LQFP-1010 pin assignment

4 Package Diagram

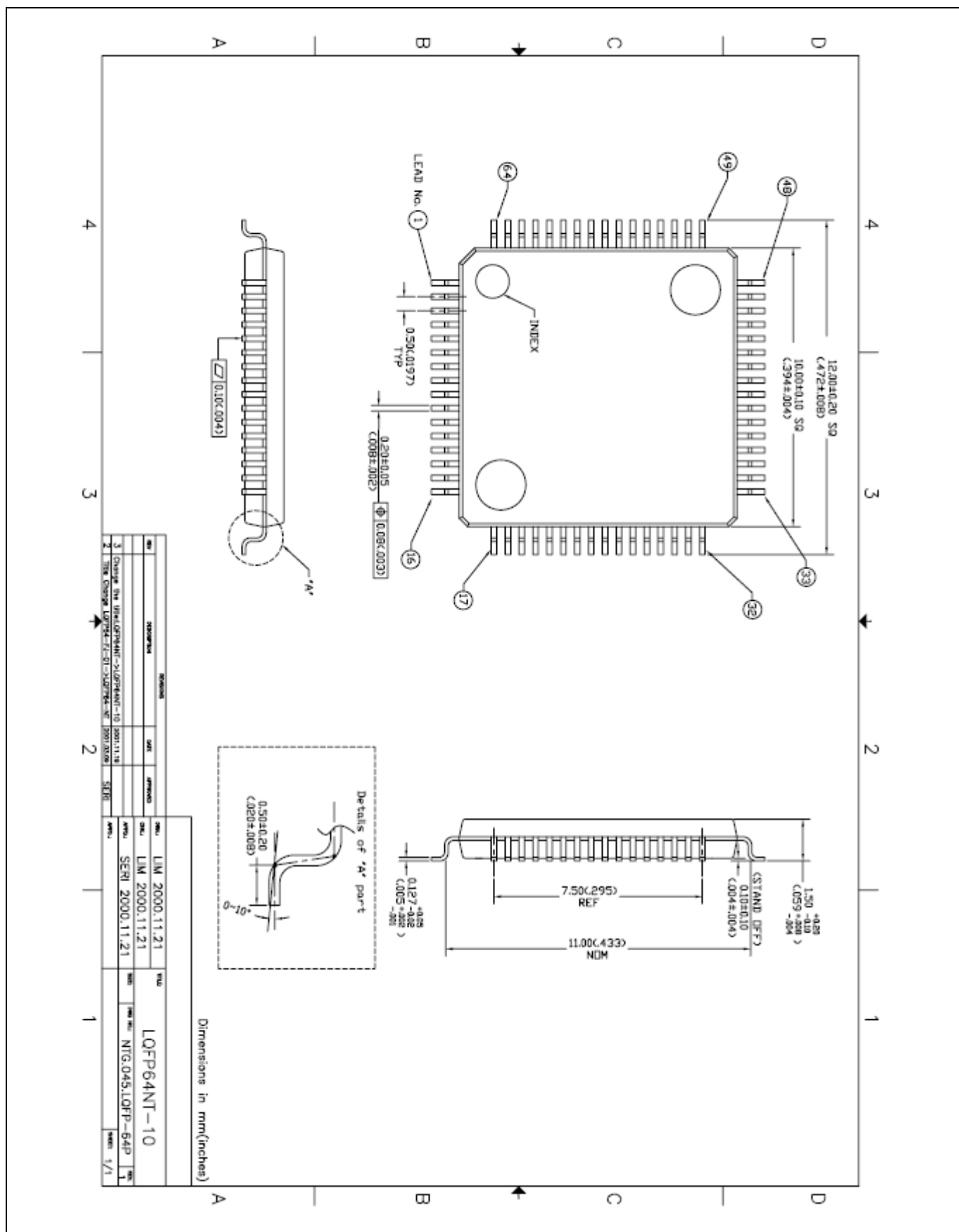

Figure 4-1. 64-Pin LQFP Package

5 Pin Description

PIN Name	I/O	Function	@RESET	Shared with
P00	I/O	Port 0 is a bit-programmable I/O port which can be configured as a Schmitt-trigger input, a push-pull output, or an open-drain output. A pull-up resistor can be specified in 1-bit unit.	Input	EINT0
P01				EINT1
P02				EINT2
P03				EINT3
P04				EINT4
P05				EINT5/EC3/BUZO
P10	I/O	Port 1 is a bit-programmable I/O port which can be configured as a Schmitt-trigger input, a push-pull output, or an open-drain output. A pull-up resistor can be specified in 1-bit unit.	Input	DSCL
P11				DSDA
P12				EINT13/PWM30/T30
P14			Input	SO
P15				SCK
P16				SI
P20	I/O	Port 2 is a bit-programmable I/O port which can be configured as an input, a push-pull output, or an open-drain output. A pull-up resistor can be specified in 1-bit unit.	Input	AN0
P21				AN1
P22				AN2
P23			Output	AN3
P24				AN4
P31	I/O	Port 3 is a bit-programmable I/O port which can be configured as an input, a push-pull output, or an open-drain output. A pull-up resistor can be specified in 1-bit unit.	Input	VLC0
P32				VLC1
P33				VLC2
P34				VLC3
P35				COM0
P36				COM1
P40	I/O	Port 4 is a bit-programmable I/O port which can be configured as an input, a push-pull output, or an open-drain output. A pull-up resistor can be specified in 1-bit unit.	Input	COM2/SEG0
P41				COM3/SEG1
P42				COM4/SEG2
P43				COM5/SEG3
P44				COM6/SEG4
P45				COM7/SEG5
P46				SEG6
P47				SEG7

Table 5-1. Normal Pin Description

PIN Name	I/O	Function	@RESET	Shared with
P50	I/O	Port 5 is a bit-programmable I/O port which can be configured as an input, a push-pull output, or an open-drain output. A pull-up resistor can be specified in 1-bit unit.	Input	SEG8
P51				SEG9
P52				SEG10
P53				SEG11
P54				SEG12
P55				SEG13
P56				SEG14
P57				SEG15
P60	I/O	Port 6 is a bit-programmable I/O port which can be configured as an input, a push-pull output, or an open-drain output. A pull-up resistor can be specified in 1-bit unit.	Input	SEG16
P61				SEG17
P62				SEG18
P63				SEG19
P64				SEG20
P65				SEG21
P66				SEG22
P67				SEG23
P72	I/O	Port 7 is a bit-programmable I/O port which can be configured as an input, a push-pull output, or an open-drain output. A pull-up resistor can be specified in 1-bit unit.	Input	SEG26/REM
P73				SEG27/T0O/PWM0O
P74				SEG28/EC0
P85	I/O	Port 8 is a bit-programmable I/O port which can be configured as an input (P85: Schmitt-trigger input), a push-pull output, or an open-drain output. A pull-up resistor can be specified in 1-bit unit	Output	SEG37/EINT10/ACK
P86				SEG38/TXD
P87				SEG39/RXD
P92	I/O	Port 9 is a bit-programmable I/O port which can be configured as an input, a push-pull output, or an open-drain output. A pull-up resistor can be specified in 1-bit unit	Input	–

Table 5-2. Normal Pin Description (Continued)

PIN Name	I/O	Function	@RESET	Shared with
EINT10	I/O	External interrupt input and Timer 0 capture input	Output	P85/SEG37/ACK
EINT13	I/O	External interrupt input and Timer 3 capture input	Input	P12/PWM30/T3O
EINT0	I/O	External interrupt inputs	Input	P00
EINT1				P01
EINT2				P02
EINT3				P03
EINT4				P04
EINT5				P05/EC3/BUZO
T0O	I/O	Timer 0 interval output	Input	P73/SEG27/PWM0O
PWM0O	I/O	Timer 0 PWM output	Input	P73/SEG27/T0O
EC0	I/O	Timer 0 event count input	Input	P74/SEG28
REM	I/O	Carrier generation output	Input	P72/SEG26
T3O	I/O	Timer 3 clock output	Input	P12/PWM30/EINT13
PWM3O	I/O	Timer 3 PWM output	Input	P12/T3O/EINT13
EC3	I/O	Timer 3 event count input	Input	P05/EINT5/BUZO
BUZO	I/O	Buzzer signal output	Input	P05/EC3/EINT5
SCK	I/O	Serial clock input/output	Input	P15
SI	I/O	Serial data input	Input	P16
SO	I/O	Serial data output	Input	P14
TXD	I/O	UART data output	Output	P86/SEG38
RXD	I/O	UART data input	Output	P87/SEG39
ACK	I/O	UART clock	Output	P85/SEG37/EINT10
VLC0– VLC3	I/O	LCD bias voltage pins	Input	P31–P34
COM0– COM1	I/O	LCD common signal output	Input	P35–P36
COM2– COM7				P40/SEG0–P45/SEG5

Table 5-3. Normal Pin Description (Continued)

PIN Name	I/O	Function	@RESET	Shared with
SEG0– SEG5	I/O	LCD segment signal output	Input	P40/COM2–P47/COM7
SEG6– SEG7				P46–P47
SEG8– SEG15				P50–P57
SEG16– SEG23				P60–P67
SEG26				P72/REM
SEG27				P73/T00/PWM00
SEG28				P74/EC0
SEG37			Output	P85/EINT10/ACK
SEG38				P86/TXD
SEG39				P87/RXD
AN0–AN3	I/O	A/D converter analog input channels	Input	P20–P23
AN4			Output	P24
RESET	I	System reset pin	–	–
DSDA	I/O	In-system programming data input/output	Input	P11
DSCL	I/O	In-system programming clock input	Input	P10
XIN, XOUT	–	Main oscillator pins	–	–
SXIN, SXOUT	–	Sub oscillator pins	–	–
VREG	–	Regulator voltage output for sub clock 0.1µF capacitor needed	–	–
AVREF	–	A/D converter reference voltage	–	–
AVSS	–	A/D converter ground	–	–
VDD, VSS	–	Power input pins	–	–

Table 5-4. Normal Pin Description (Continued)

NOTE)

1. If the P10 and P11 pins are connected to the programmer during power-on reset, the pins are automatically configured as In-System programming pins.
2. The P10 and P11 pins are configured as inputs with internal pull-up resistor only during the reset or power-on reset.

6 Port Structures

6.1 General Purpose I/O Port

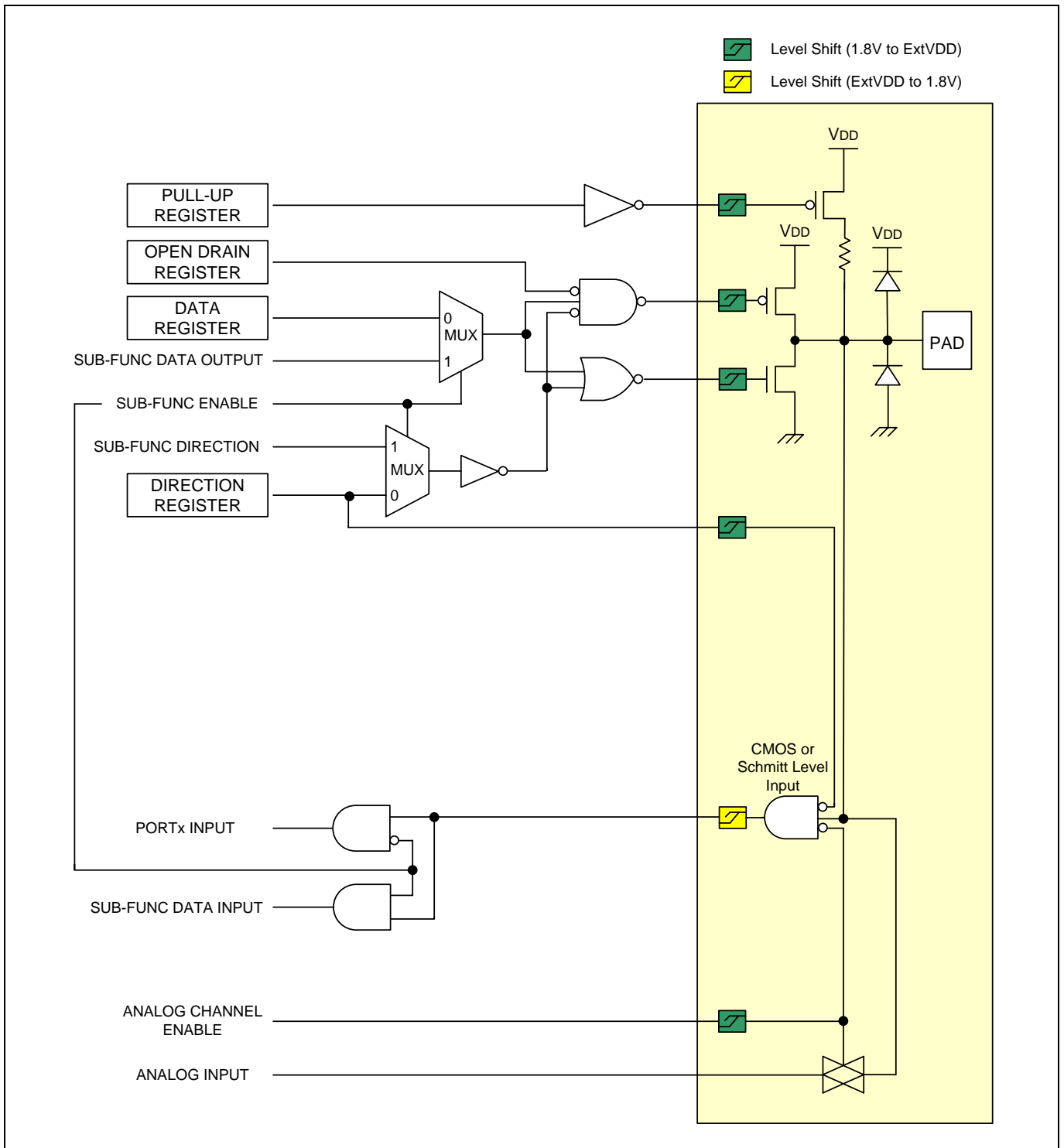

Figure 6-1. General Purpose I/O Port

6.2 External Interrupt I/O Port

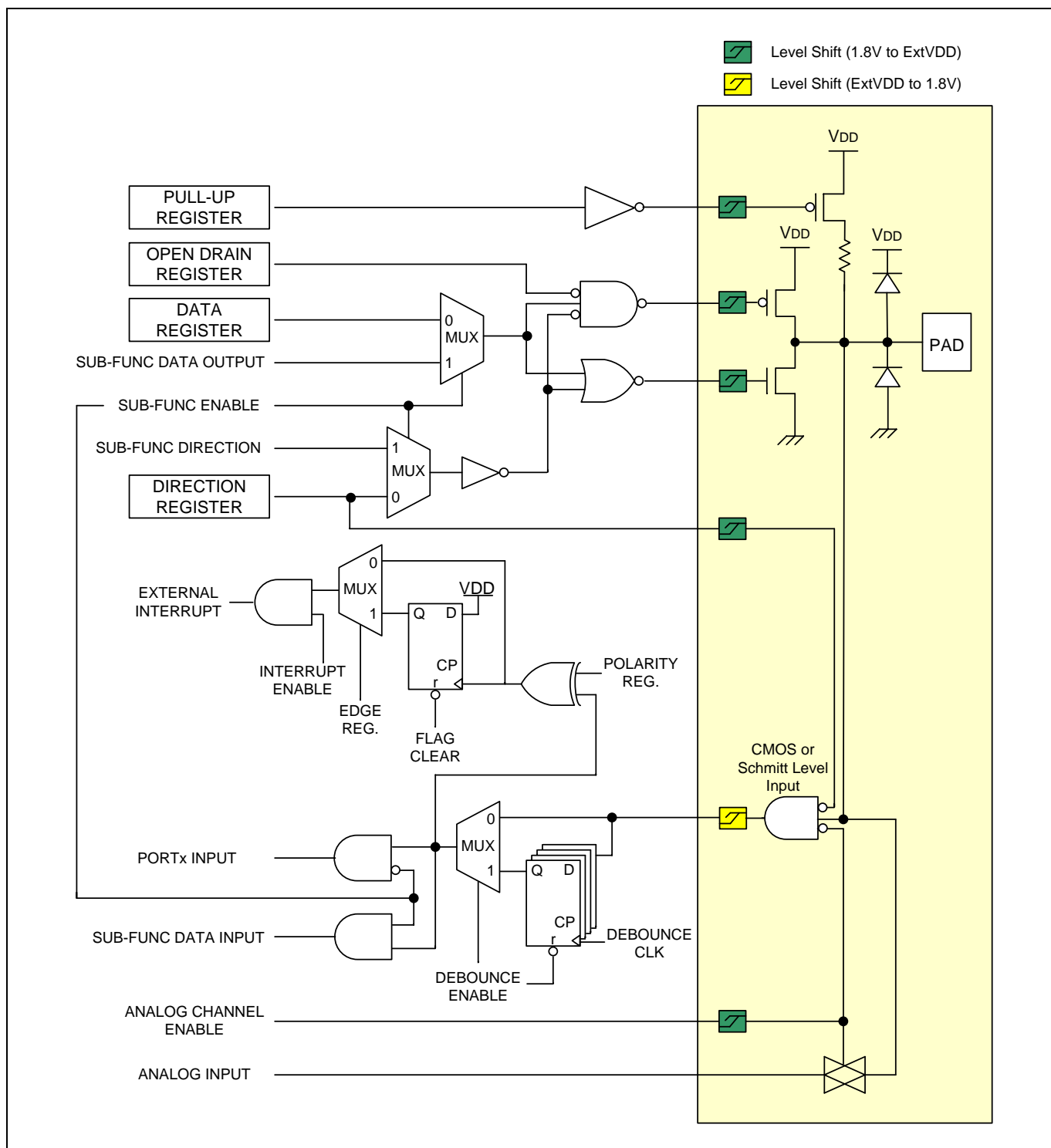

Figure 6-2. External Interrupt I/O Port

7 Electrical Characteristics

7.1 Absolute Maximum Ratings

Parameter	Symbol	Rating	Unit	Note
Supply Voltage	VDD	-0.3 ~ +6.5	V	–
Normal Voltage Pin	V _I	-0.3 ~ VDD+0.3	V	Voltage on any pin with respect to VSS
	V _O	-0.3 ~ VDD+0.3	V	
	I _{OH}	-10	mA	Maximum current output sourced by (I _{OH} per I/O pin)
	∑I _{OH}	-80	mA	Maximum current (∑I _{OH})
	I _{OL}	60	mA	Maximum current sunk by (I _{OL} per I/O pin)
	∑I _{OL}	120	mA	Maximum current (∑I _{OL})
Total Power Dissipation	P _T	600	mW	–
Storage Temperature	T _{STG}	-65 ~ +150	°C	–

Table 7-1. Absolute Maximum Ratings

NOTE)

- Stresses beyond those listed under “Absolute Maximum Ratings” may cause permanent damage to the device. This is a stress rating only and functional operation of the device at any other conditions beyond those indicated in the operational sections of this specification is not implied. Exposure to absolute maximum rating conditions for extended periods may affect device reliability.

7.2 Recommended Operating Conditions

Parameter	Symbol	Conditions	(T _A = -40°C ~ +85°C)			Unit	
			MIN	TYP	MAX		
Supply Voltage	VDD	f _X = 32 ~ 35kHz	Sub Crystal	1.8	–	5.5	V
		f _X = 1.0 ~ 4.2MHz	Main Crystal, Internal RC	1.8	–	5.5	
		f _X = 1.0 ~ 10.0MHz		2.7	–	5.5	
		f _X = 1.0 ~ 12.0MHz		3.0	–	5.5	
Operating Temperature	T _{OPR}	VDD= 1.8 ~ 5.5V		-40	–	85	°C

Table 7-2. Recommended Operating Conditions

7.3 A/D Converter Characteristics

(T_A= -40°C ~ +85°C, VDD= 1.8V ~ 5.5V, VSS= 0V)

Parameter	Symbol	Conditions	MIN	TYP	MAX	Unit	
Resolution		–	–	12	–	bit	
Integral Linear Error	ILE	AVREF= 2.7V – 5.5V fx= 8MHz	–	–	±6	LSB	
Differential Linearity Error	DLE		–	–	±1		
Zero Offset Error	ZOE		–	–	±5		
Full Scale Error	FSE		–	–	±5		
Conversion Time	t _{CON}	12bit resolution, 8MHz	20	–	–	us	
Analog Input Voltage	V _{AN}	–	AVSS	–	AVREF	V	
Analog Reference Voltage	AVREF	–	1.8	–	VDD		
Analog Ground Voltage	AVSS	–	VSS	–	VSS+0.3		
Analog Input Leakage Current	I _{AN}	AVREF= 5.12V	–	–	2	uA	
ADC Operating Current	I _{ADC}	Enable	VDD= 5.12V	–	1	2	mA
		Disable		–	–	0.1	uA

Table 7-3. A/D Converter Characteristics

NOTE)

1. Zero offset error is the difference between 000000000000 and the converted output for zero input voltage (VSS).
2. Full scale error is the difference between 111111111111 and the converted output for full-scale input voltage (AVREF).

7.4 Power-On Reset Characteristics

(T_A= -40°C ~ +85°C, VDD= 1.8V ~ 5.5V, VSS= 0V)

Parameter	Symbol	Conditions	MIN	TYP	MAX	Unit
RESET Release Level	V _{POR}	–	–	1.4	–	V
VDD Voltage Rising Time	t _R	–	0.05	–	30.0	V/ms
POR Current	I _{POR}	–	–	0.2	–	uA

Table 7-4. Power-On Reset Characteristics

7.5 Low Voltage Reset and Low Voltage Indicator Characteristics

(T_A= -40°C ~ +85°C, VDD= 1.8V ~ 5.5V)

Parameter	Symbol	Conditions		MIN	TYP	MAX	Unit
Detection Level	V _{LVR} V _{LVI}	The LVR can select all levels but LVI can select other levels except 1.60V.		–	1.60	1.79	V
				1.85	2.00	2.15	
				1.95	2.10	2.25	
				2.05	2.20	2.35	
				2.17	2.32	2.47	
				2.29	2.44	2.59	
				2.39	2.59	2.79	
				2.55	2.75	2.95	
				2.73	2.93	3.13	
				2.94	3.14	3.34	
				3.18	3.38	3.58	
				3.37	3.67	3.97	
				3.70	4.00	4.30	
4.10	4.40	4.70					
Hysteresis	ΔV	–		–	50	150	mV
Minimum Pulse Width	t _{LW}	–		100	–	–	us
LVR and LVI Current	I _{BL}	Enable (Both)	VDD= 3V, RUN Mode	–	14.0	24.0	uA
		Enable (One of two)		–	10.0	18.0	
		Disable (Both)	VDD= 3V	–	–	0.1	

Table 7-5. LVR and LVI Characteristics

7.6 Internal RC Oscillator Characteristics

(T_A= -40°C ~ +85°C, VDD= 1.8V ~ 5.5V)

Parameter	Symbol	Conditions	MIN	TYP	MAX	Unit
Frequency	f _{IRC}	T _A = 25°C	–	8.0	–	MHz
Tolerance	–	T _A = -40°C to +85°C With 0.1uF Bypass capacitor	-3.5	–	+3.5	%
Clock Duty Ratio	TOD	–	40	50	60	%
Stabilization Time	t _{WDTS}	T _A = 25°C	–	–	100	us
IRC Current	I _{IRC}	Enable	–	0.2	–	mA
		Disable	–	–	0.1	uA

Table 7-6. Internal RC Oscillator Characteristics

NOTE)

1. A 0.1uF bypass capacitor should be connected to VDD and VSS. Refer to the “7.19 Recommended Circuit and Layout”.

7.7 Internal Watch-Dog Timer RC Oscillator Characteristics

(T_A= -40°C ~ +85°C, VDD= 1.8V ~ 5.5V, VSS= 0V)

Parameter	Symbol	Conditions	MIN	TYP	MAX	Unit
Frequency	f _{WDTRC}	–	2	5	10	kHz
Stabilization Time	t _{WDTS}	–	–	–	1	ms
WDTRC Current	I _{WDTRC}	Enable	–	1	–	uA
		Disable	–	–	0.1	

Table 7-7. Internal WDTRC Oscillator Characteristics

7.8 DC Characteristics

(T_A= -40°C ~ +85°C, VDD= 1.8V ~ 5.5V, VSS= 0V, f_{XIN}= 12MHz)

Parameter	Symbol	Conditions	MIN	TYP	MAX	Unit	
Input High Voltage	V _{IH1}	P0x, P1x, P85, RESETB	0.8VDD	–	VDD	V	
	V _{IH2}	All input pins except V _{IH1}	0.7VDD	–	VDD	V	
Input Low Voltage	V _{IL1}	P0x, P1x, P85, RESETB	–	–	0.2VDD	V	
	V _{IL2}	All input pins except V _{IL1}	–	–	0.3VDD	V	
Output High Voltage	V _{OH1}	All output ports; I _{OH} = -2mA, VDD= 4.5V	VDD-1.0	–	–	V	
Output Low Voltage	V _{OL1}	P1x, P2x; I _{OL} = 15mA, VDD= 4.5V	–	–	1.0		
	V _{OL2}	All output ports except V _{OL1} ; I _{OL} = 10mA, VDD=4.5V	–	–	1.0	V	
Input High Leakage Current	I _{IH}	All input ports	–	–	1	uA	
Input Low Leakage Current	I _{IL}	All input ports	-1	–	–	uA	
Pull-Up Resistor	R _{PU1}	V _I =0V, T _A = 25°C All Input ports	VDD=5.0V	25	50	100	kΩ
			VDD=3.0V	50	100	200	
	R _{PU2}	V _I =0V, T _A = 25°C RESETB	VDD=5.0V	150	250	400	kΩ
			VDD=3.0V	300	500	700	
OSC feedback resistor	R _{X1}	XIN= VDD, XOUT= VSS T _A = 25°C, VDD= 5V	600	1200	2000	kΩ	
	R _{X2}	SXIN=VDD, SXOUT=VSS T _A = 25 °C ,VDD=5V	2500	5000	10000		
LCD Voltage Dividing Resistor	R _{LCD}	T _A = 25 °C	25	50	80	kΩ	
Common Driver Voltage Drop	V _{DC}	VDD= 2.7V to 5.5V, V _{LC} D-COM _i , (i=0-7) -15uA per common pin	–	–	120	mV	
Segment Driver Voltage Drop	V _{DS}	VDD= 2.7V to 5.5V, V _{LC} D-SEG _x , (x=0-39) -15uA per common pin	–	–	120	mV	
Middle Output Voltage (NOTE)	V _{LC1}	VDD= 2.7V to 5.5V, 1/4 bias LCD clock= 0Hz, VLC0=VDD	0.75VDD-0.2	0.75VDD	0.75VDD+0.2	V	
	V _{LC2}		0.50VDD-0.2	0.5VDD	0.50VDD+0.2		
	V _{LC3}		0.25VDD-0.2	0.25VDD	0.25VDD+0.2		

Table 7-8. DC Characteristics

NOTE)

1. It is middle output voltage when the VDD and the V_{LC0} node are connected.

($T_A = -40^{\circ}\text{C} \sim +85^{\circ}\text{C}$, $V_{DD} = 1.8\text{V} \sim 5.5\text{V}$, $V_{SS} = 0\text{V}$, $f_{XIN} = 12\text{MHz}$)

Parameter	Symbol	Condition	MIN	TYP	MAX	Unit	
Supply Current	I_{DD1} (RUN)	$f_{XIN} = 12\text{MHz}$, $V_{DD} = 5\text{V} \pm 10\%$	–	3.0	6.0	mA	
		$f_{XIN} = 10\text{MHz}$, $V_{DD} = 3\text{V} \pm 10\%$	–	2.2	4.4		
		$f_{XIN} = 4.2\text{MHz}$, $V_{DD} = 3\text{V} \pm 10\%$	–	1.6	3.2		
	I_{DD2} (IDLE)	$f_{XIN} = 12\text{MHz}$, $V_{DD} = 5\text{V} \pm 10\%$	–	2.0	4.0	mA	
		$f_{XIN} = 10\text{MHz}$, $V_{DD} = 3\text{V} \pm 10\%$	–	1.3	2.6		
		$f_{XIN} = 4.2\text{MHz}$, $V_{DD} = 3\text{V} \pm 10\%$	–	0.7	1.4		
	I_{DD3}	$f_{XIN} = 32.768\text{kHz}$ $V_{DD} = 3\text{V} \pm 10\%$	Sub RUN	–	60.0	90.0	μA
	I_{DD4}	$T_A = 25^{\circ}\text{C}$, $\text{PSAVE} = 1$	Sub IDLE	–	4.0	8.0	μA
I_{DD5}	STOP, $V_{DD} = 5\text{V} \pm 10\%$, $T_A = 25^{\circ}\text{C}$		–	0.5	3.0	μA	

Table 7-9. DC Characteristics (Continued)

NOTE)

1. Where the f_{XIN} is an external main oscillator, f_{SUB} is an external sub oscillator, the f_{IRC} is an internal RC oscillator, and the f_x is the selected system clock.
2. All supply current items don't include the current of an internal Watch-dog timer RC (WDTRC) oscillator and a peripheral block.
3. All supply current items include the current of the power-on reset (POR) block.

7.9 Serial I/O Characteristics

($T_A = -40^{\circ}\text{C} \sim +85^{\circ}\text{C}$, $V_{DD} = 1.8\text{V} \sim 5.5\text{V}$)

Parameter	Symbol	Conditions	MIN	TYP	MAX	Unit
SCK cycle time	t_{KCY}	External SCK source	1,000			ns
		Internal SCK source	1,000			
SCK high, low width	t_{KH}, t_{KL}	External SCK source	500			ns
		Internal SCK source	$t_{KCY}/2-50$			
SI setup time to SCK high	t_{SIK}	External SCK source	250	-	-	ns
		Internal SCK source	250			
SI hold time to SCK high	t_{KSI}	External SCK source	400			ns
		Internal SCK source	400			
Output delay for SCK to SO	t_{KSO}	External SCK source	-	-	300	ns
		Internal SCK source			250	
Interrupt input high, low width	t_{INTH}, t_{INTL}	All interrupt, $V_{DD} = 5\text{V}$	200	-	-	ns
RESETB input low width	t_{RSL}	Input, $V_{DD} = 5\text{V}$	10	-	-	us

Table 7-10. Serial I/O Characteristics

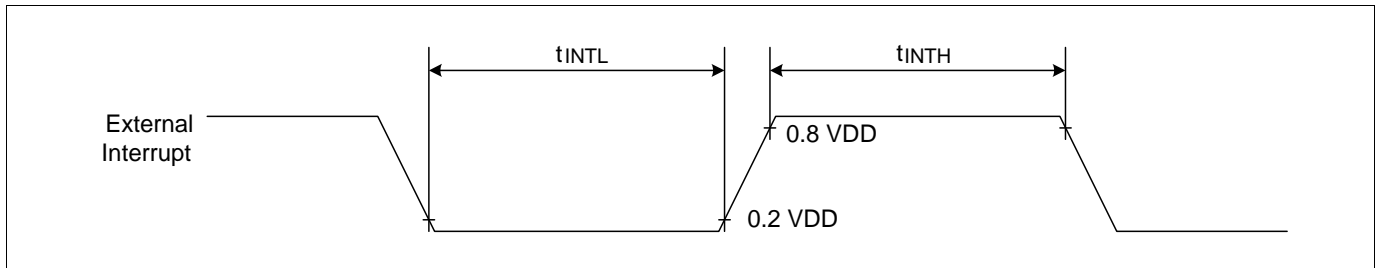

Figure 7-1. Input Timing for External Interrupts

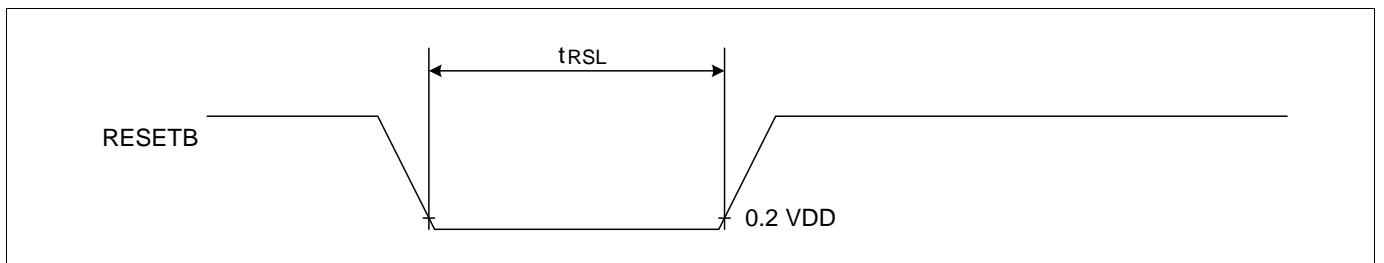

Figure 7-2. Input Timing for RESETB

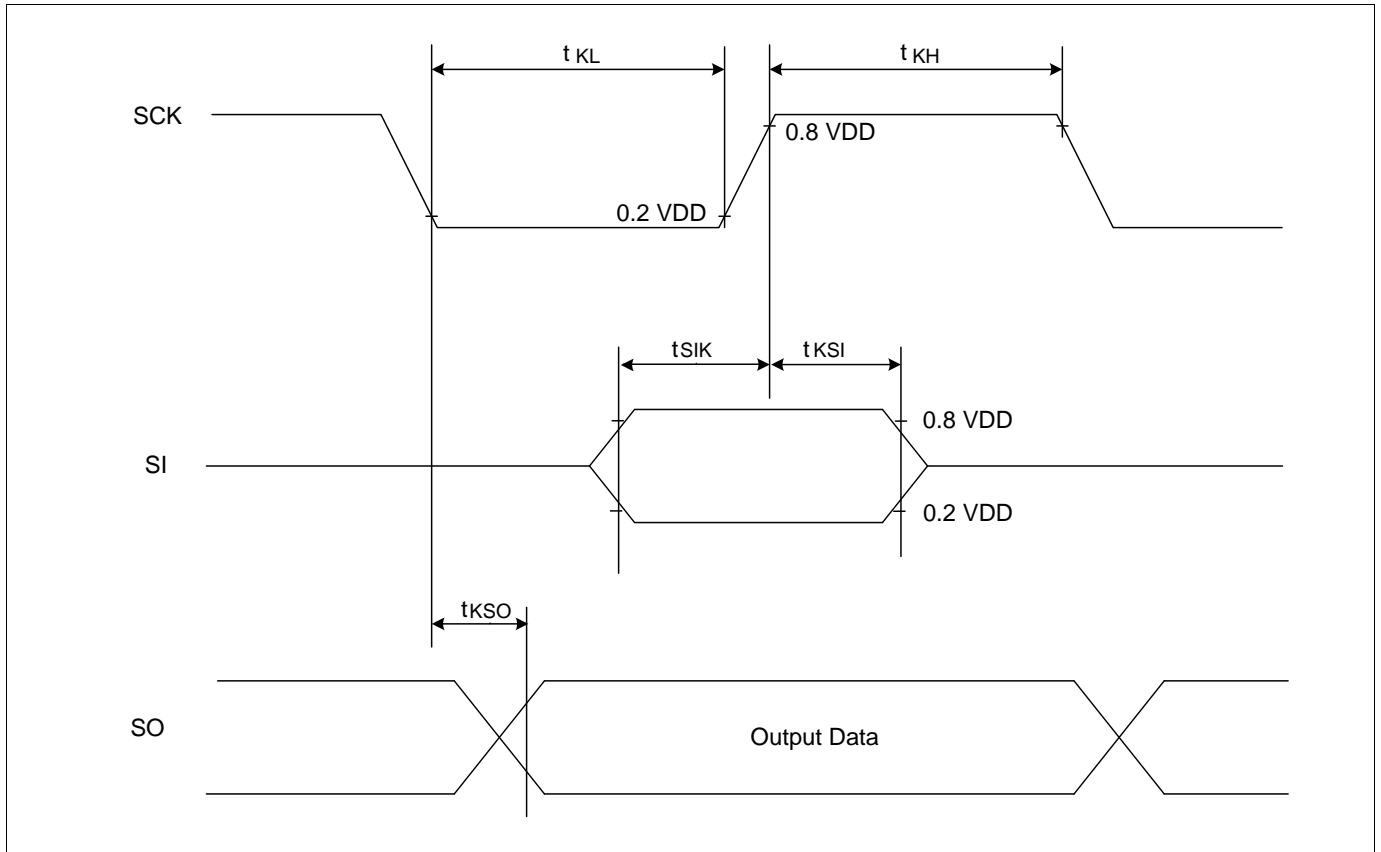

Figure 7-3. Serial Interface Data Transfer Timing

7.10 UART Characteristics

($T_A = -40^{\circ}\text{C} \sim +85^{\circ}\text{C}$, $V_{DD} = 1.8\text{V} \sim 5.5\text{V}$, $f_{XIN} = 11.1\text{MHz}$)

Parameter	Symbol	MIN	TYP	MAX	Unit
Serial port clock cycle time	t_{SCK}	1250	$t_{CPU} \times 16$	1650	ns
Output data setup to clock rising edge	t_{S1}	590	$t_{CPU} \times 13$	–	ns
Clock rising edge to input data valid	t_{S2}	–	–	590	ns
Output data hold after clock rising edge	t_{H1}	$t_{CPU} - 50$	t_{CPU}	–	ns
Input data hold after clock rising edge	t_{H2}	0	–	–	ns
Serial port clock High, Low level width	t_{HIGH}, t_{LOW}	470	$t_{CPU} \times 8$	970	ns

Table 7-11. UART Characteristics

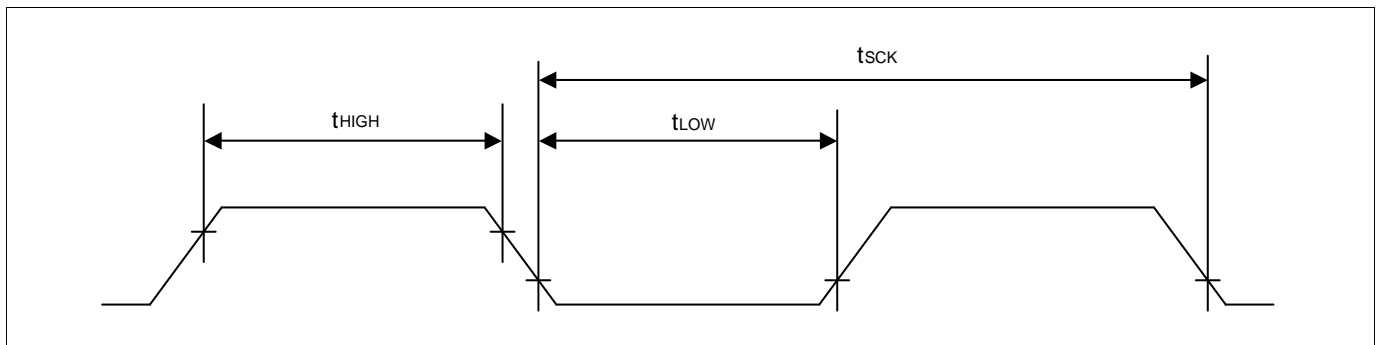

Figure 7-4. Input Timing for RESETB

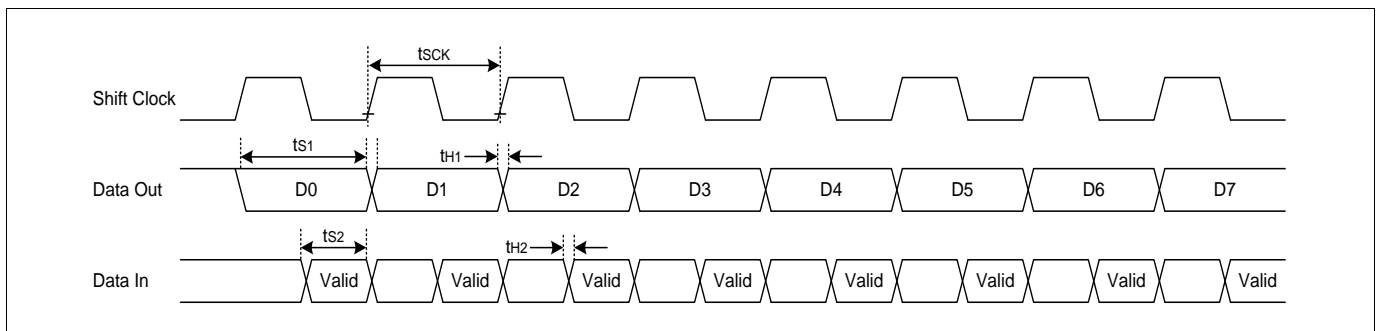

Figure 7-5. Input Timing for RESETB

7.11 Data Retention Voltage in Stop Mode

($T_A = -40^{\circ}\text{C} \sim +85^{\circ}\text{C}$, $V_{DD} = 1.8\text{V} \sim 5.5\text{V}$)

Parameter	Symbol	Conditions	MIN	TYP	MAX	Unit
Data retention supply voltage	V_{DDDR}	–	1.8	–	5.5	V
Data retention supply current	I_{DDDR}	$V_{DDDR} = 1.8\text{V}$, ($T_A = 25^{\circ}\text{C}$), Stop mode	–	–	1	μA

Table 7-12. Data Retention Voltage in Stop Mode

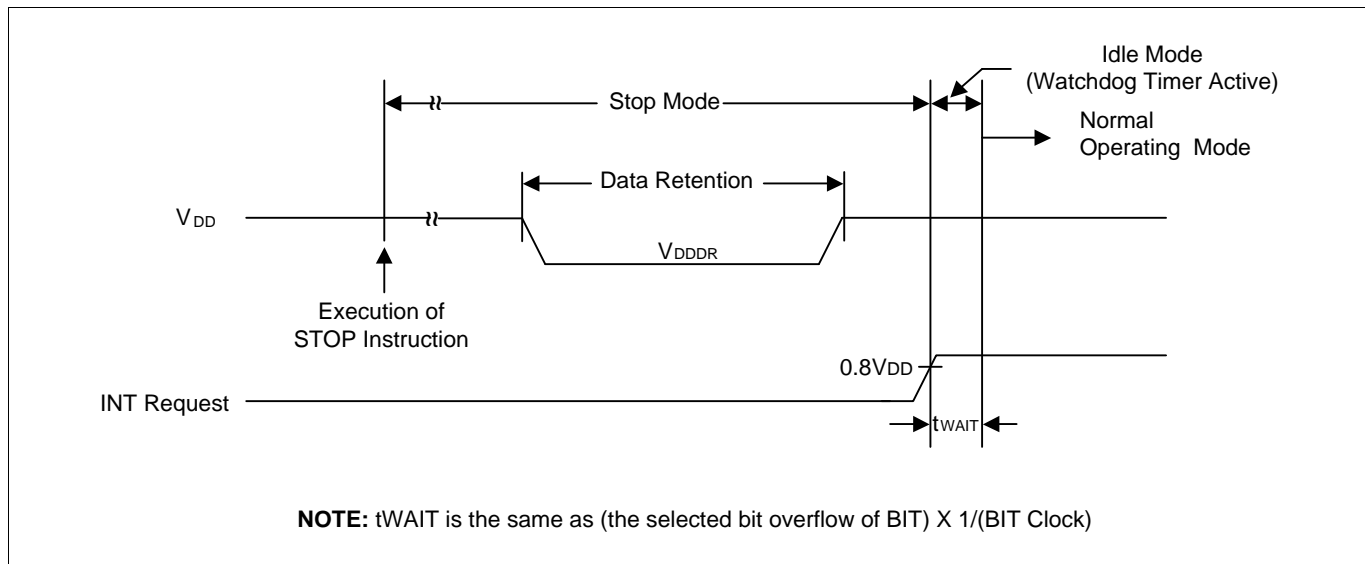

Figure 7-6. Stop Mode Release Timing when Initiated by an Interrupt

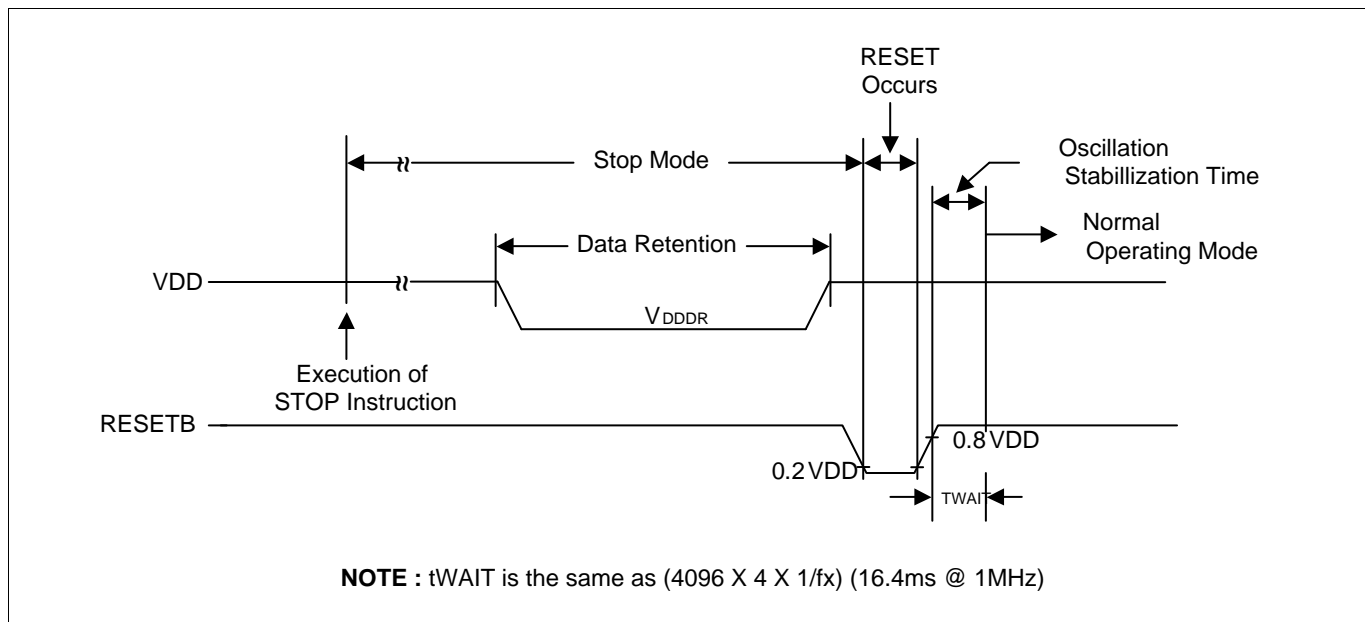

Figure 7-7. Stop Mode Release Timing when Initiated by RESETB

7.12 Internal Flash Rom Characteristics

($T_A = -40^\circ\text{C} \sim +85^\circ\text{C}$, $V_{DD} = 1.8\text{V} \sim 5.5\text{V}$, $V_{SS} = 0\text{V}$)

Parameter	Symbol	Condition	MIN	TYP	MAX	Unit
Sector Write Time	t_{FSW}	–	–	2.5	2.7	ms
Sector Erase Time	t_{FSE}	–	–	2.5	2.7	
Hard-Lock Time	t_{FHL}	–	–	2.5	2.7	
Page Buffer Reset Time	t_{FBR}	–	–	–	5	us
Flash Programming Frequency	f_{PGM}	–	1	–	–	MHz
Endurance of Write/Erase (Sector 0~507)	N_{FWE}	–	–	–	10,000	Times
Endurance of Write/Erase (Sector 508~511)					100,000	

Table 7-13. Internal Flash Rom Characteristics

NOTE)

1. During a flash operation, SCLK[1:0] of SCCR must be set to “00” or “01” (INT-RC OSC or Main X-TAL for system clock).

7.13 Input/Output Capacitance

($T_A = -40^\circ\text{C} \sim +85^\circ\text{C}$, $V_{DD} = 0\text{V}$)

Parameter	Symbol	Condition	MIN	TYP	MAX	Unit
Input Capacitance	C_{IN}	fx= 1MHz Unmeasured pins are connected to VSS	–	–	10	pF
Output Capacitance	C_{OUT}					
I/O Capacitance	C_{IO}					

Table 7-14. Input/Output Capacitance

7.14 Main Clock Oscillator Characteristics

($T_A = -40^{\circ}\text{C} \sim +85^{\circ}\text{C}$, $V_{DD} = 1.8\text{V} \sim 5.5\text{V}$)

Oscillator	Parameter	Condition	MIN	TYP	MAX	Unit
Crystal	Main oscillation frequency	1.8V – 5.5V	1.0	–	4.2	MHz
		2.7V – 5.5V	1.0	–	10.0	
		3.0V – 5.5V	1.0	–	12.0	
Ceramic Oscillator	Main oscillation frequency	1.8V – 5.5V	1.0	–	4.2	MHz
		2.7V – 5.5V	1.0	–	10.0	
		3.0V – 5.5V	1.0	–	12.0	
External Clock	XIN input frequency	1.8V – 5.5V	1.0	–	4.2	MHz
		2.7V – 5.5V	1.0	–	10.0	
		3.0V – 5.5V	1.0	–	12.0	

Table 7-15. Main Clock Oscillator Characteristics

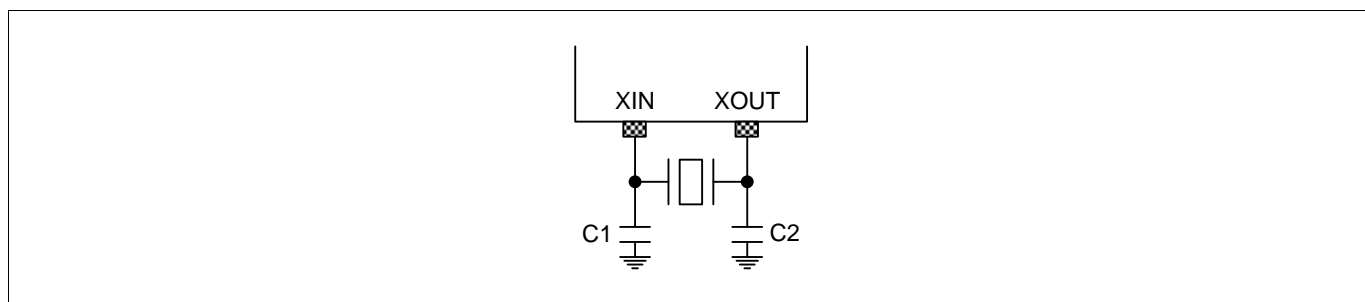

Figure 7-8. Crystal/Ceramic Oscillator

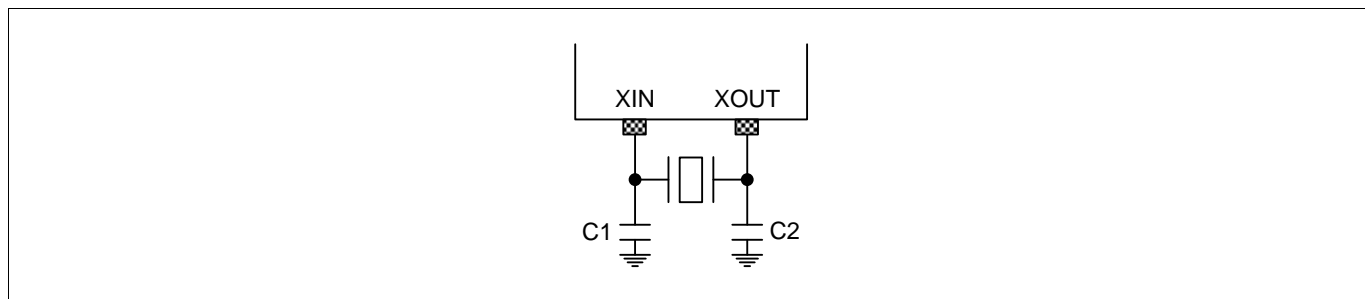

Figure 7-9. External Clock

7.15 Sub Clock Oscillator Characteristics

($T_A = -40^{\circ}\text{C} \sim +85^{\circ}\text{C}$, $V_{DD} = 1.8\text{V} \sim 5.5\text{V}$)

Oscillator	Parameter	Condition	MIN	TYP	MAX	Unit
Crystal	Sub oscillation frequency	1.8V – 5.5V	32	32.768	35	kHz
External Clock	SXIN input frequency		32	–	100	kHz

Table 7-16. Sub Clock Oscillator Characteristics

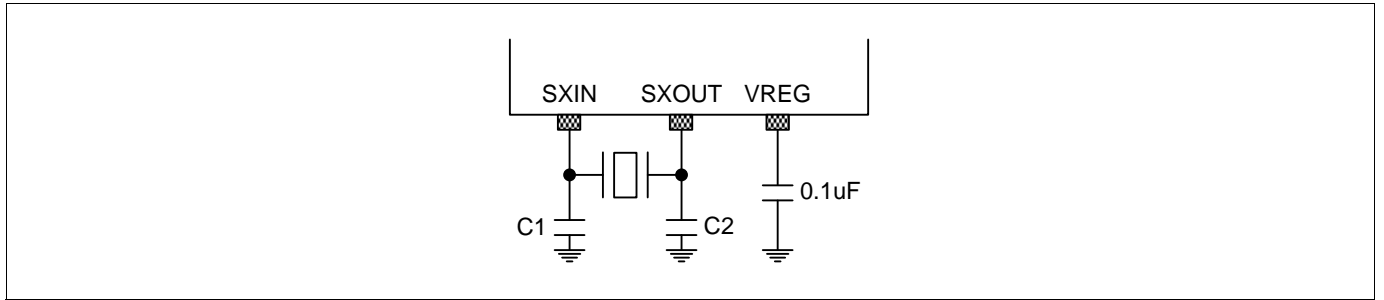

Figure 7-10. Crystal Oscillator

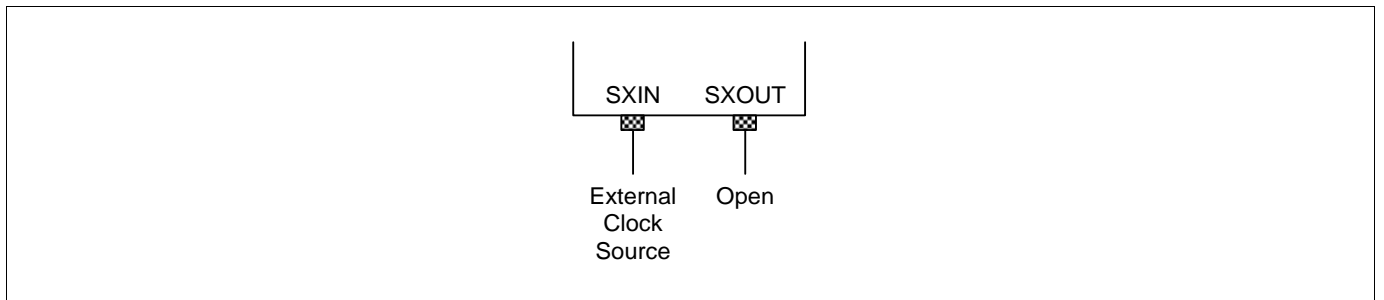

Figure 7-11. External Clock

7.16 Main Oscillation Stabilization Characteristics

($T_A = -40^\circ\text{C} \sim +85^\circ\text{C}$, $V_{DD} = 1.8\text{V} \sim 5.5\text{V}$)

Oscillator	Parameter	MIN	TYP	MAX	Unit
Crystal	$f_x > 1\text{MHz}$	-	-	60	ms
Ceramic	Oscillation stabilization occurs when VDD is equal to the minimum oscillator voltage range.	-	-	10	ms
External Clock	$f_{XIN} = 1 \text{ to } 12\text{MHz}$ XIN input high and low width (t_{XH} , t_{XL})	42	-	500	ns

Table 7-17. Main Oscillation Stabilization Characteristics

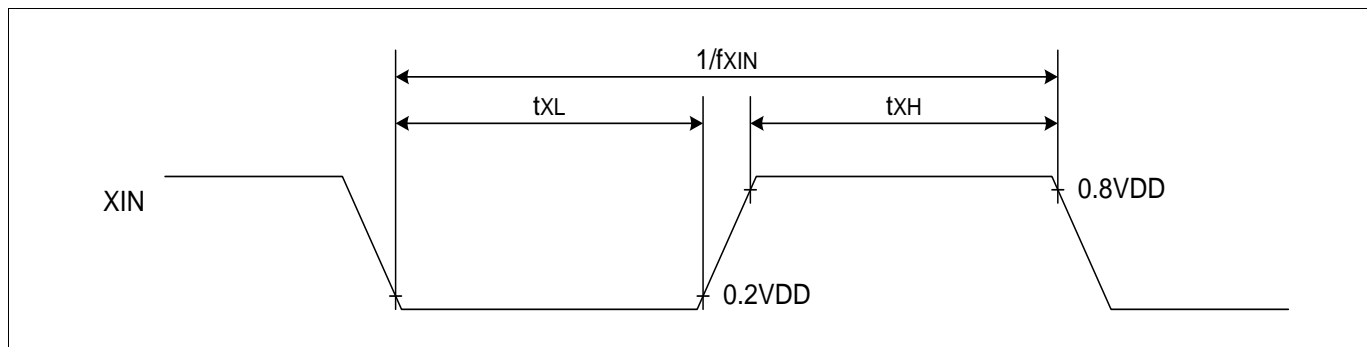

Figure 7-12. Clock Timing Measurement at XIN

7.17 Sub Oscillation Characteristics

($T_A = -40^{\circ}\text{C} \sim +85^{\circ}\text{C}$, $V_{DD} = 1.8\text{V} \sim 5.5\text{V}$)

Oscillator	Parameter	MIN	TYP	MAX	Unit
Crystal	–	–	–	10	s
External Clock	SXIN input high and low width (t_{XH} , t_{XL})	5	–	15	us

Table 7-18. Main Oscillation Stabilization Characteristics

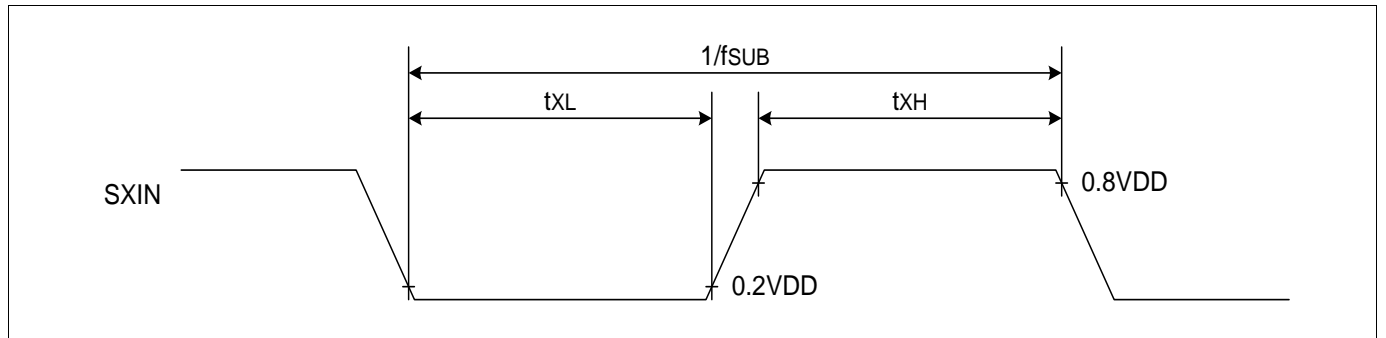

Figure 7-13. Clock Timing Measurement at SXIN

7.18 Operating Voltage Range

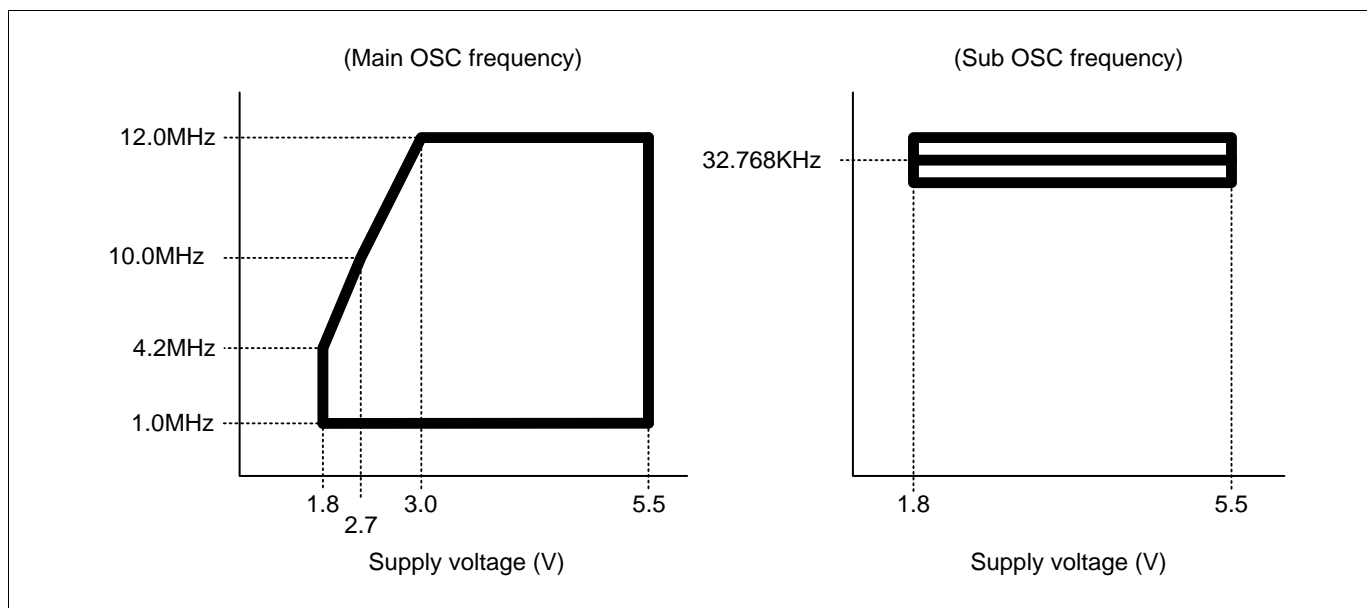

Figure 7-14. Operating Voltage Range

7.19 Recommended Circuit and Layout

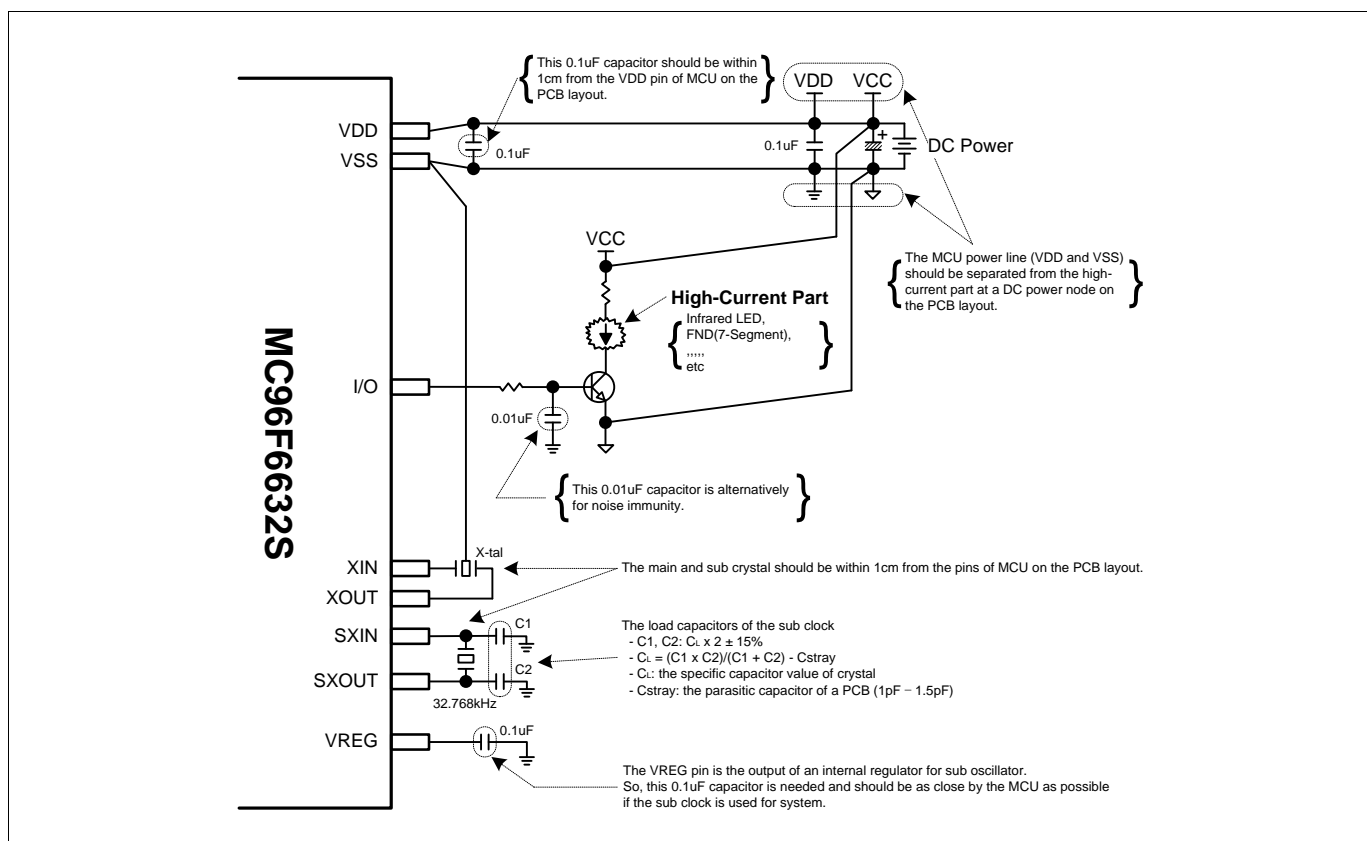

Figure 7-15. Recommended Circuit and Layout

7.20 Typical Characteristics

These graphs and tables provided in this section are only for design guidance and are not tested or guaranteed. In graphs or tables some data are out of specified operating range (e.g. out of specified VDD range). This is only for information and devices are guaranteed to operate properly only within the specified range.

The data presented in this section is a statistical summary of data collected on units from different lots over a period of time. "Typical" represents the mean of the distribution while "max" or "min" represents (mean + 3σ) and (mean - 3σ) respectively where σ is standard deviation.

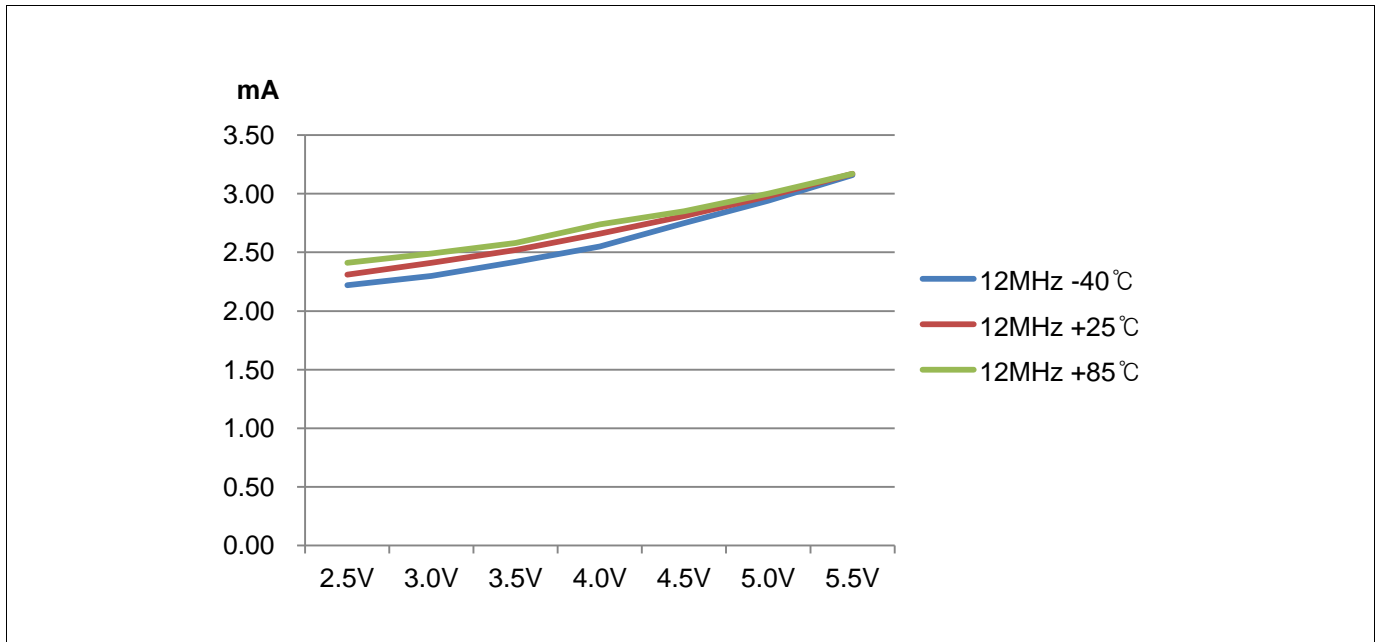

Figure 7-16. RUN (IDD1) Current

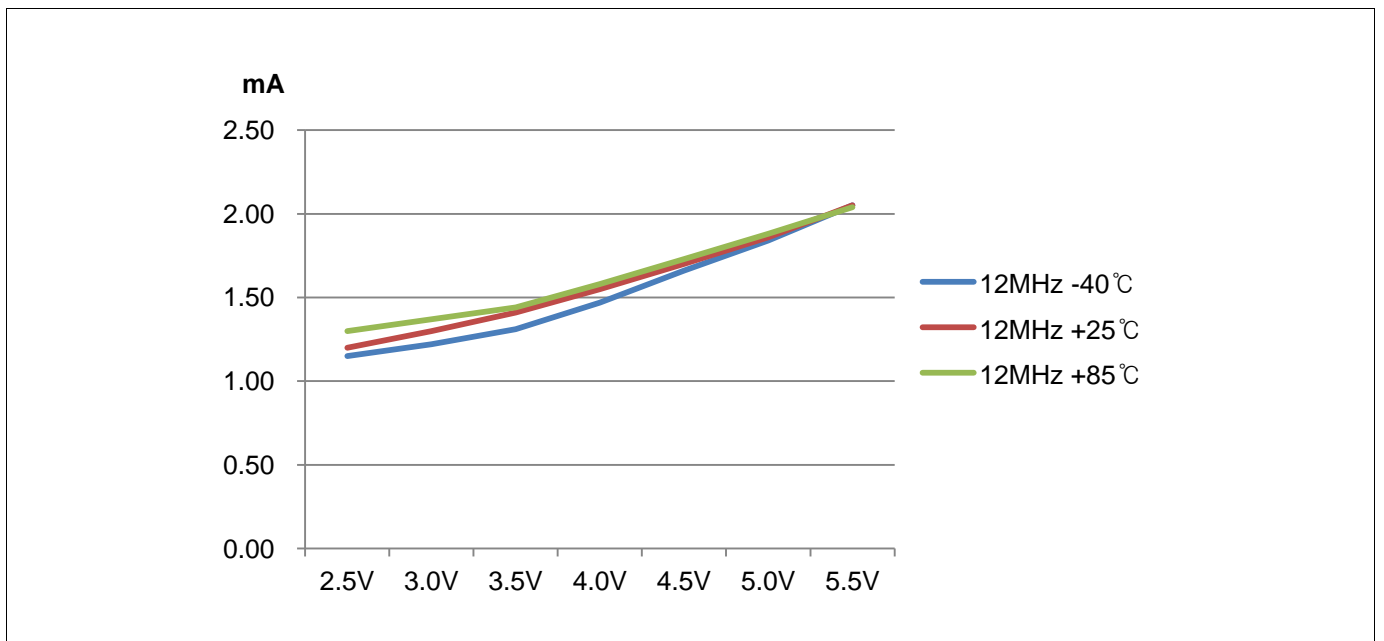

Figure 7-17. IDLE (IDD2) Current

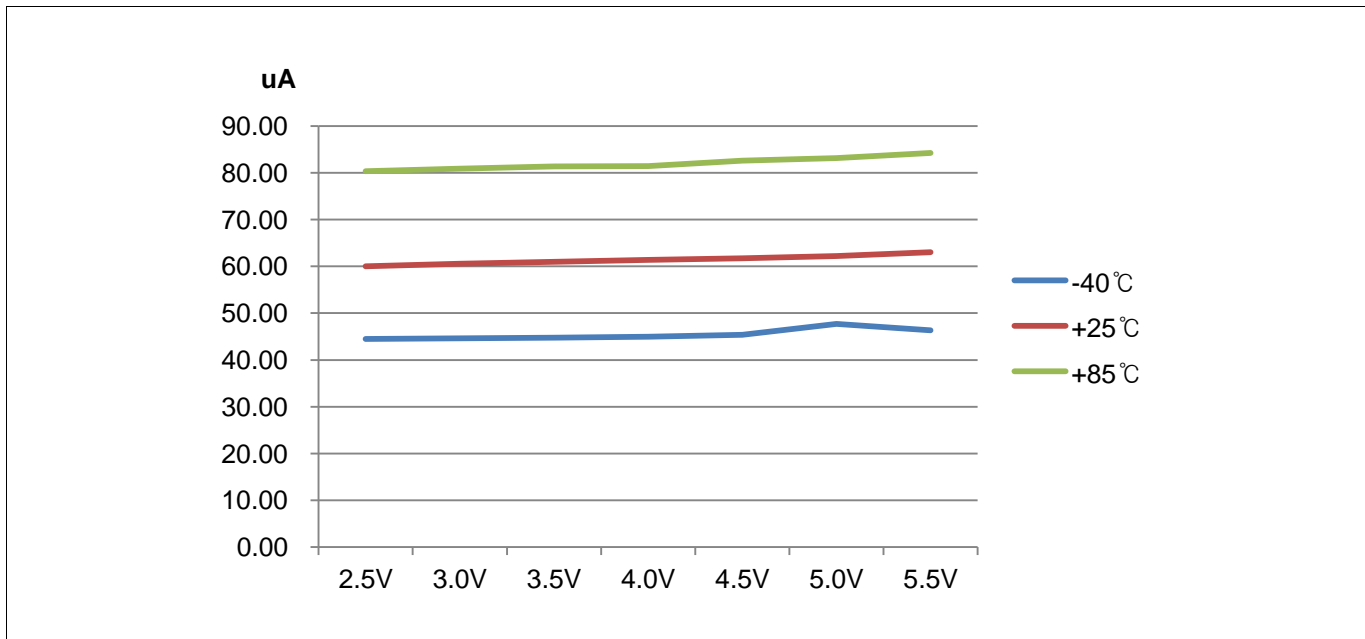

Figure 7-18. SUB RUN (IDD3) Current

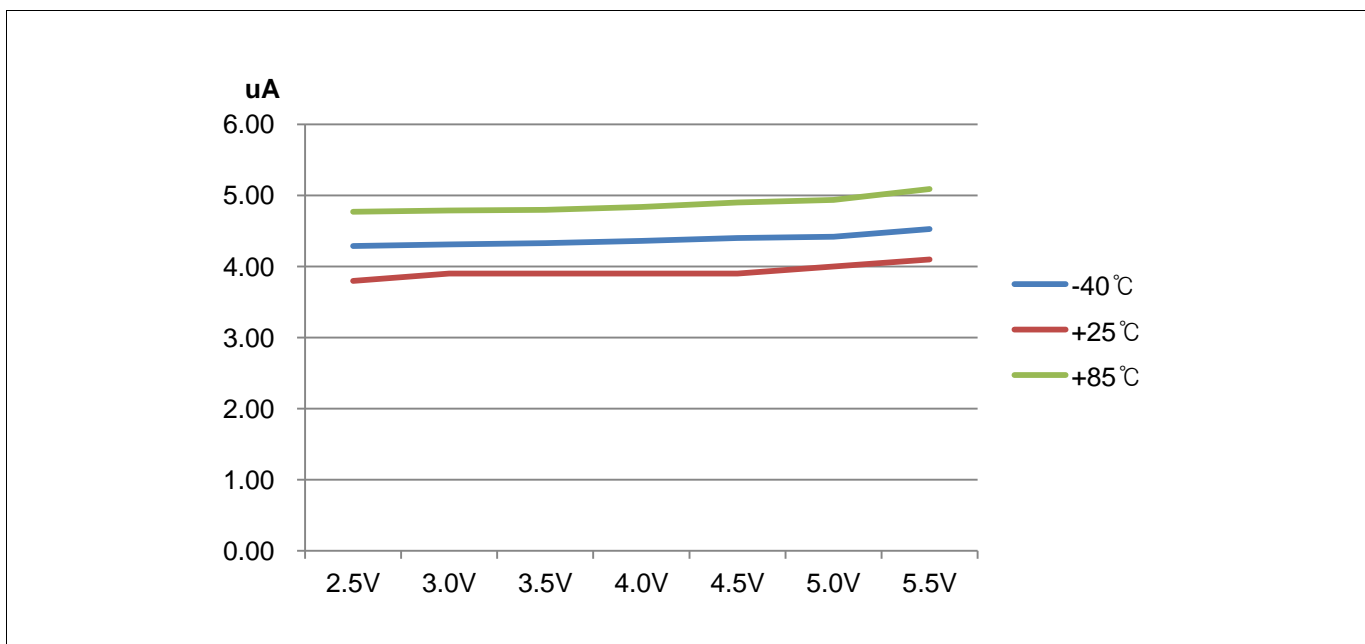

Figure 7-19. SUB IDLE (IDD4) Current

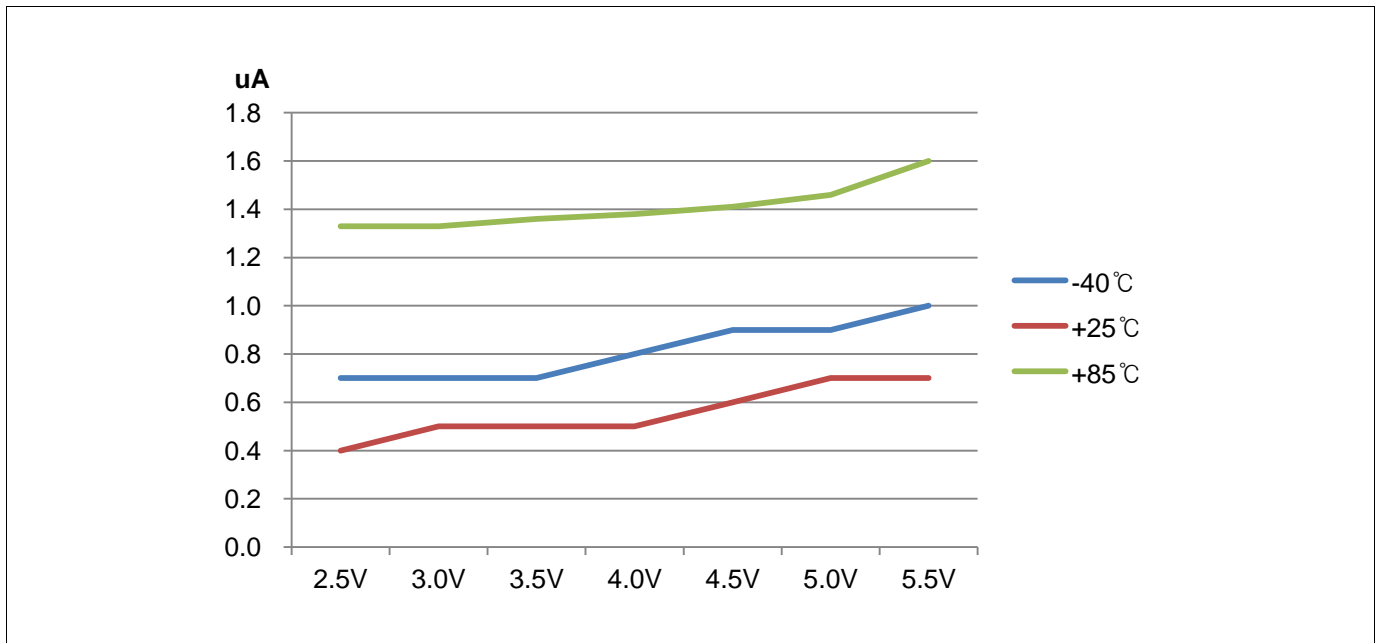

Figure 7-20. STOP (IDD5) Current

8 Memory

The MC96F6632S addresses two separate address memory stores: Program memory and Data memory. The logical separation of Program and Data memory allows Data memory to be accessed by 8-bit addresses, which makes the 8-bit CPU access the data memory more rapidly. Nevertheless, 16-bit Data memory addresses can also be generated through the DPTR register.

MC96F6632S provides on-chip 32Kbytes of the ISP type flash program memory, which can be read and written to. Internal data memory (IRAM) is 256bytes and it includes the stack area. External data memory (XRAM) is 1Kbytes and it includes 30bytes of LCD display RAM

8.1 Program Memory

A 16-bit program counter is capable of addressing up to 64Kbytes, but this device has just 32Kbytes program memory space.

Figure 8-1 shows the map of the lower part of the program memory. After reset, the CPU begins execution from location 0000H. Each interrupt is assigned a fixed location in program memory. The interrupt causes the CPU to jump to that location, where it commences execution of the service routine. External interrupt 10, for example, is assigned to location 000BH. If external interrupt 10 is going to be used, its service routine must begin at location 000BH. If the interrupt is not going to be used, its service location is available as general purpose program memory. If an interrupt service routine is short enough (as is often the case in control applications), it can reside entirely within that 8bytes interval. Longer service routines can use a jump instruction to skip over subsequent interrupt locations, if other interrupts are in use.

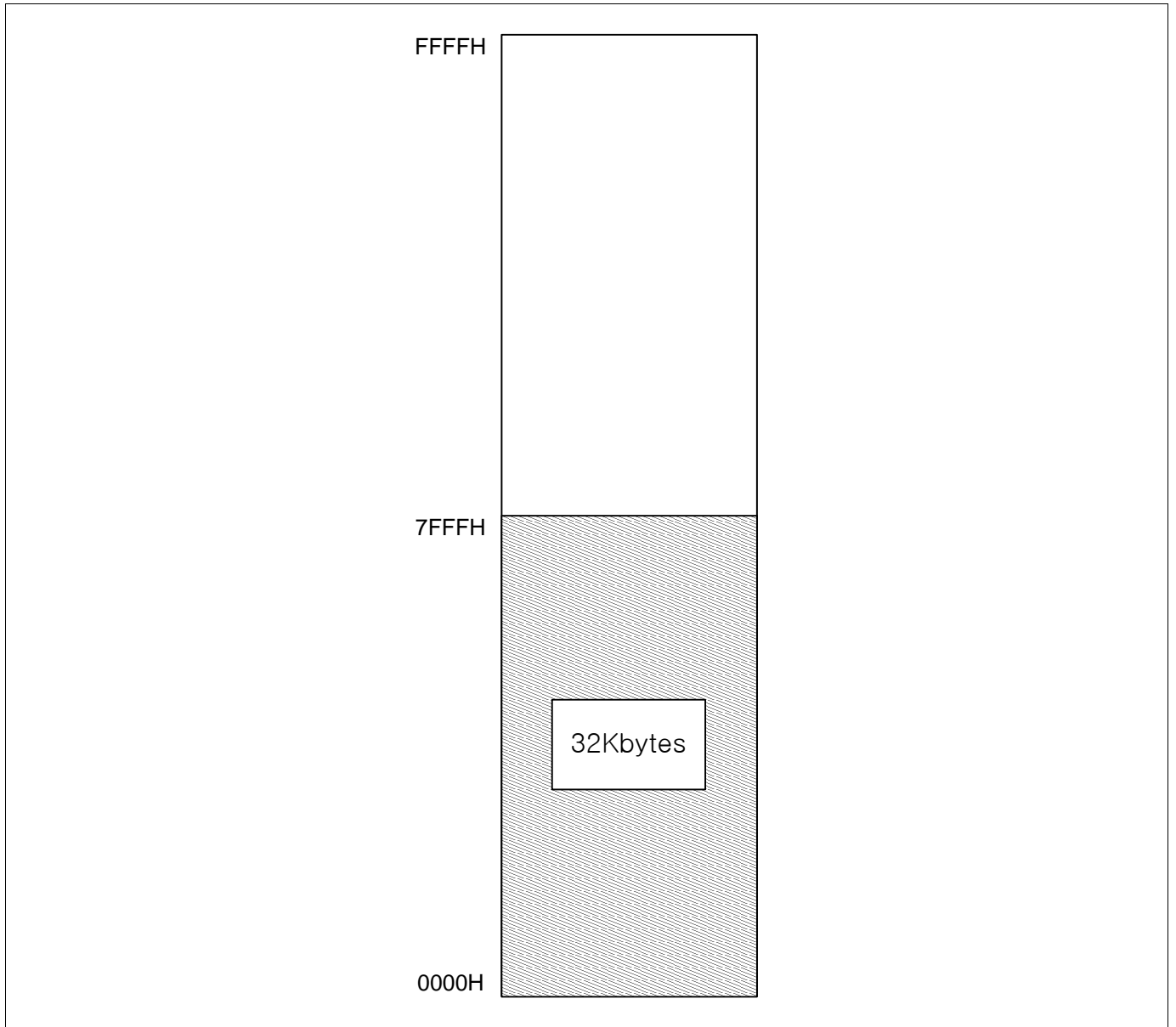

Figure 8-1. Program Memory

8.2 Data Memory

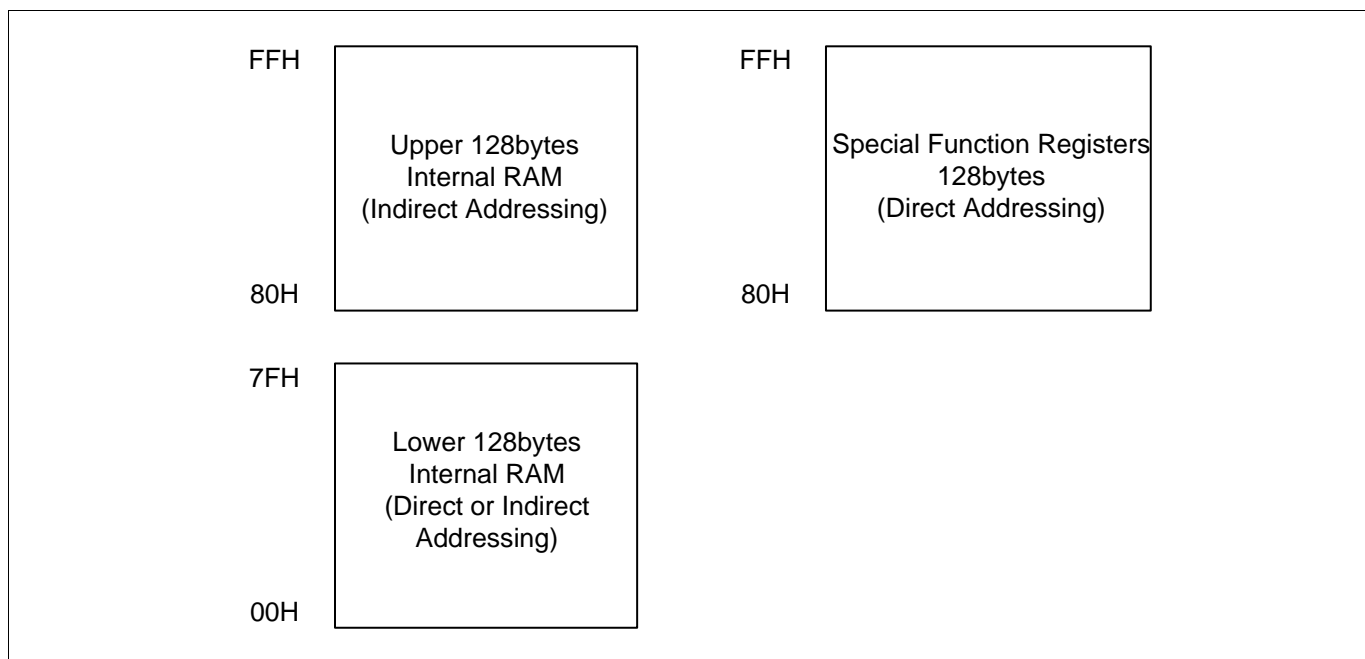

Figure 8-2. Data Memory Map

The internal data memory space is divided into three blocks, which are generally referred to as the lower 128bytes, upper 128bytes, and SFR space.

Internal data memory addresses are always one byte wide, which implies an address space of only 256bytes. However, in fact the addressing modes for internal RAM can accommodate up to 384bytes by using a simple trick. Direct addresses higher than 7FH access one memory space and indirect addresses higher than 7FH access a different memory space. Thus Figure 8-2 shows the upper 128bytes and SFR space occupying the same block of addresses, 80H through FFH, although they are physically separate entities.

The lower 128bytes of RAM are present in all 8051 devices as mapped in Figure 8-3. The lowest 32bytes are grouped into 4 banks of 8 registers. Program instructions call out these registers as R0 through R7. Two bits in the Program Status Word select which register bank is in use. This allows more efficient use of code space, since register instructions are shorter than instructions that use direct addressing.

The next 16bytes above the register banks form a block of bit-addressable memory space. The 8051 instruction set includes a wide selection of single-bit instructions, and the 128bits in this area can be directly addressed by these instructions. The bit addresses in this area are 00H through 7FH.

All of the bytes in the lower 128bytes can be accessed by either direct or indirect addressing. The upper 128bytes RAM can only be accessed by indirect addressing. These spaces are used for data RAM and stack.

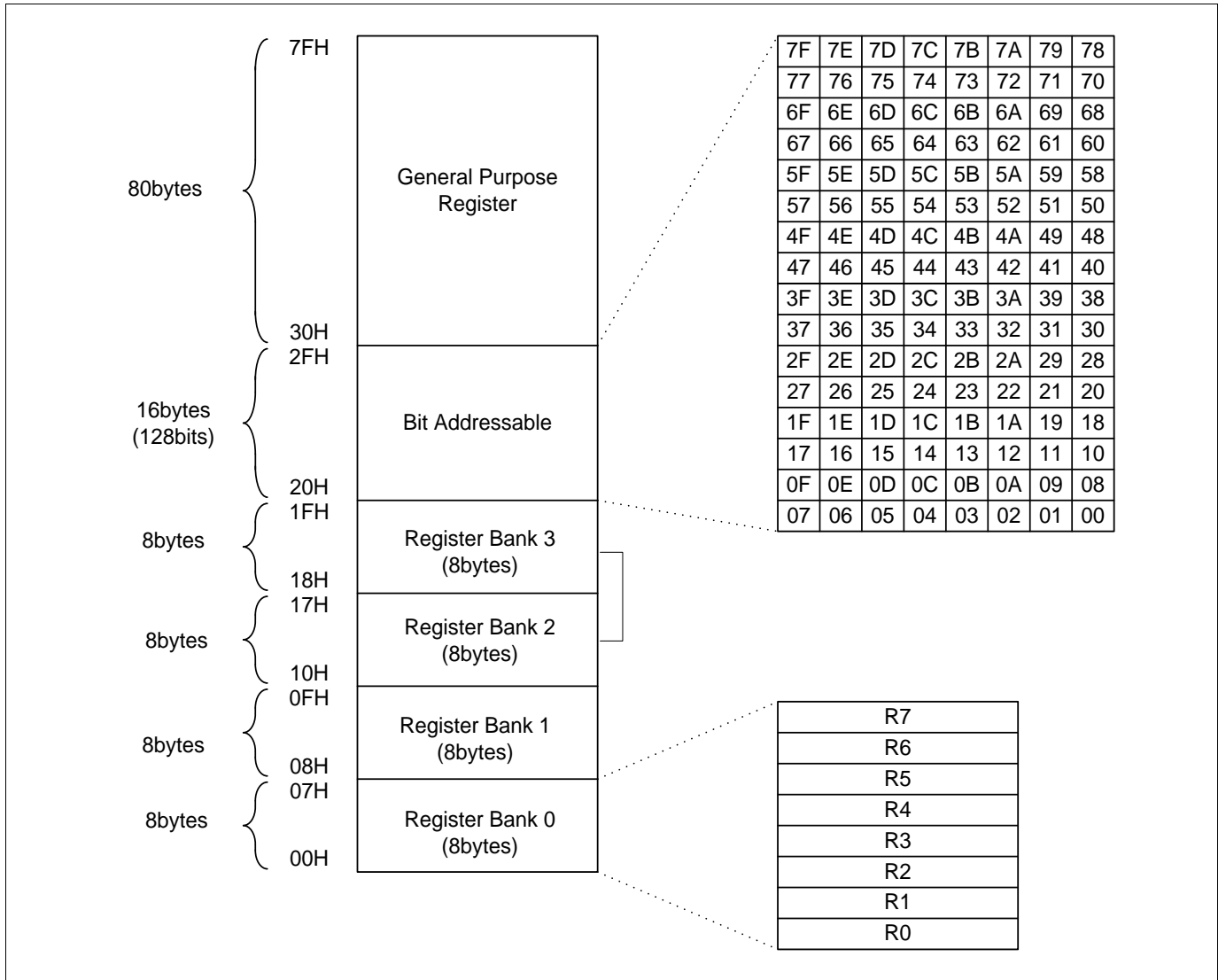

Figure 8-3. Lower 128bytes RAM

8.3 XRAM Memory

MC96F6632S has 1Kbytes XRAM. This area has no relation with RAM/FLASH. It can be read and written to through SFR with 8-bit unit.

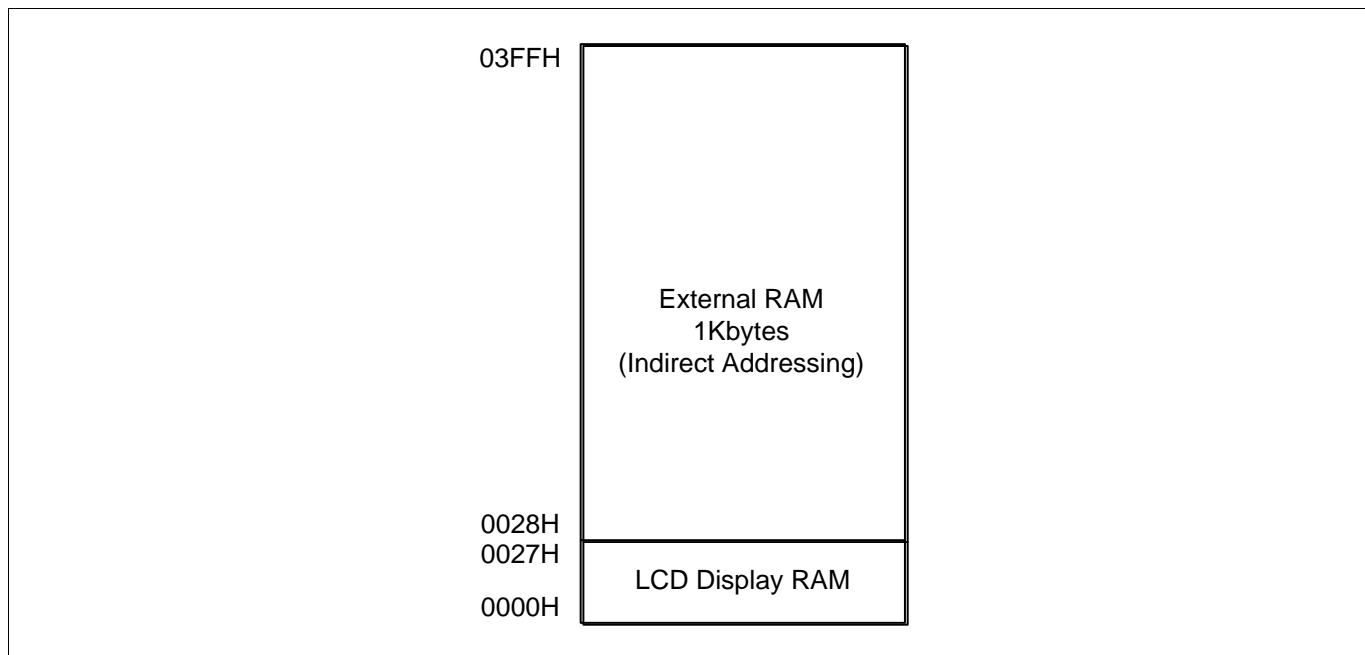

Figure 8-4. XDATA Memory Area

8.4 SFR Map

8.4.1 SFR Map Summary

-	Reserved
	M8051 compatible

	00H/8H ⁽¹⁾	01H/9H	02H/0AH	03H/0BH	04H/0CH	05H/0DH	06H/0EH	07H/0FH
0F8H	IP1	-	FSADRH	FSADRM	FSADRL	FIDR	FMCR	-
0F0H	B	PFSR3	PFSR4	PFSR5	PFSR6	-	PFSR8	LVR CR
0E8H	P9CDR	P0DB	P1DB	LCDCRL	LCDCRH	PFSR0	PFSR1	PFSR2
0E0H	ACC	LVICR	UARTCR1	UARTCR2	UARTCR3	UARTST	UARTBD	UARTDR
0D8H	P8	OSCCR	P4PU	P5PU	P6PU	P7PU	P8PU	-
0D0H	PSW	P8IO	P8OD	-	P0PU	P1PU	P2PU	P3PU
0C8H	P7	P7IO	T1CR	T1CNT	T1DRL	T1DRH	CARCR	P7OD
0C0H	P6	P6IO	T3CR	TIFR	T3CNTL	T3CNTH	T3DRL/ T3CDRL	T3DRH/ T3CDRH
0B8H	IP	P5IO	T2CR	P6OD	T2CNTL	T2CNTH	T2DRL	T2DRH
0B0H	P5	P4IO	T0CR	T0CNT	T0DR/ T0CDR	SIOCR	SIODR	SIOPS
0A8H	IE	IE1	IE2	IE3	EIENAB0	EIFLAG0	EIEDGE0	EIPOL0
0A0H	P4	P3IO	EO	EIENAB1	EIFLAG1	EIEDGE1	EIPOL1	P5OD
98H	P3	P2IO	ADCCRL	ADC DRL	ADCDRH	ADCCRH	WTCR	WTDR/ WTCNT
90H	P2	P1IO	P0OD	P1OD	P2OD	P3OD	P4OD	BUZCR
88H	P1	P0IO	SCCR	BITCR	BITCNT	WDTCR	WDTDR/ WDTCNT	BUZDR
80H	P0	SP	DPL	DPH	DPL1	DPH1	RSTFR	PCON

NOTE)

- (1)These registers are bit-addressable.

8.4.2 SFR Map

Address	Function	Symbol	R/W	@Reset								
				7	6	5	4	3	2	1	0	
80H	P0 Data Register	P0	R/W	–	–	0	0	0	0	0	0	0
81H	Stack Pointer	SP	R/W	0	0	0	0	0	1	1	1	1
82H	Data Pointer Register Low	DPL	R/W	0	0	0	0	0	0	0	0	0
83H	Data Pointer Register High	DPH	R/W	0	0	0	0	0	0	0	0	0
84H	Data Pointer Register Low 1	DPL1	R/W	0	0	0	0	0	0	0	0	0
85H	Data Pointer Register High 1	DPH1	R/W	0	0	0	0	0	0	0	0	0
86H	Reset Flag Register	RSTFR	R/W	1	x	0	–	1	–	–	–	–
87H	Power Control Register	PCON	R/W	0	–	–	–	0	0	0	0	0
88H	P1 Data Register	P1	R/W	–	0	0	0	–	0	0	0	0
89H	P0 Direction Register	P0IO	R/W	–	–	0	0	0	0	0	0	0
8AH	System and Clock Control Register	SCCR	R/W	0	0	–	–	–	–	0	0	0
8BH	Basic Interval Timer Control Register	BITCR	R/W	0	–	–	–	0	0	0	1	1
8CH	Basic Interval Timer Counter Register	BITCNT	R	0	0	0	0	0	0	0	0	0
8DH	Watch Dog Timer Control Register	WDTCR	R/W	0	0	0	–	–	–	–	0	0
8EH	Watch Dog Timer Data Register	WDTDR	W	1	1	1	1	1	1	1	1	1
	Watch Dog Timer Counter Register	WDCNT	R	0	0	0	0	0	0	0	0	0
8FH	BUZZER Data Register	BUZDR	R/W	1	1	1	1	1	1	1	1	1
90H	P2 Data Register	P2	R/W	–	–	–	1	1	0	0	0	0
91H	P1 Direction Register	P1IO	R/W	–	0	0	0	–	0	0	0	0
92H	P0 Open-drain Selection Register	P0OD	R/W	–	–	0	0	0	0	0	0	0
93H	P1 Open-drain Selection Register	P1OD	R/W	–	0	0	0	–	0	0	0	0
94H	P2 Open-drain Selection Register	P2OD	R/W	–	–	–	1	1	0	0	0	0
95H	P3 Open-drain Selection Register	P3OD	R/W	–	0	0	0	0	0	0	–	–
96H	P4 Open-drain Selection Register	P4OD	R/W	0	0	0	0	0	0	0	0	0
97H	BUZZER Control Register	BUZCR	R/W	–	–	–	–	–	0	0	0	0
98H	P3 Data Register	P3	R/W	–	0	0	0	0	0	0	–	–
99H	P2 Direction Register	P2IO	R/W	–	–	–	1	1	0	0	0	0
9AH	A/D Converter Control Low Register	ADCCRL	R/W	0	0	0	0	0	0	0	0	0
9BH	A/D Converter Data Low Register	ADCRL	R	x	x	x	x	x	x	x	x	x
9CH	A/D Converter Data High Register	ADCRH	R	x	x	x	x	x	x	x	x	x
9DH	A/D Converter Control High Register	ADCCRH	R/W	0	–	–	–	–	0	0	0	0
9EH	Watch Timer Control Register	WTCR	R/W	0	–	–	0	0	0	0	0	0
9FH	Watch Timer Data Register	WTDR	W	0	1	1	1	1	1	1	1	1
	Watch Timer Counter Register	WTCNT	R	–	0	0	0	0	0	0	0	0

Table 8-1. Absolute Maximum Ratings

Address	Function	Symbol	R/W	@Reset							
				7	6	5	4	3	2	1	0
A0H	P4 Data Register	P4	R/W	0	0	0	0	0	0	0	0
A1H	P3 Direction Register	P3IO	R/W	–	0	0	0	0	0	0	–
A2H	Extended Operation Register	EO	R/W	–	–	–	0	–	0	0	0
A3H	External Interrupt Enable Register 1	EIENAB1	R/W	–	–	–	–	–	–	0	0
A4H	External Interrupt Flag Register 1	EIFLAG1	R/W	–	–	–	–	–	–	0	0
A5H	External Interrupt Edge Register 1	EIEDGE1	R/W	–	–	–	–	–	–	0	0
A6H	External Interrupt Polarity Register 1	EIPOL1	R/W	–	–	–	–	–	–	0	0
A7H	P5 Open-drain Selection Register	P5OD	R/W	0	0	0	0	0	0	0	0
A8H	Interrupt Enable Register	IE	R/W	0	–	0	–	–	0	0	–
A9H	Interrupt Enable Register 1	IE1	R/W	–	–	0	0	0	–	–	–
AAH	Interrupt Enable Register 2	IE2	R/W	–	–	0	0	0	0	0	0
ABH	Interrupt Enable Register 3	IE3	R/W	–	–	–	0	0	0	–	0
ACH	External Interrupt Enable Register 0	EIENAB0	R/W	–	–	0	0	0	0	0	0
ADH	External Interrupt Flag Register 0	EIFLAG0	R/W	–	–	0	0	0	0	0	0
AEH	External Interrupt Edge Register 0	EIEDGE0	R/W	–	–	0	0	0	0	0	0
AFH	External Interrupt Polarity Register 0	EIPOL0	R/W	–	–	0	0	0	0	0	0
B0H	P5 Data Register	P5	R/W	0	0	0	0	0	0	0	0
B1H	P4 Direction Register	P4IO	R/W	0	0	0	0	0	0	0	0
B2H	Timer 0 Control Register	T0CR	R/W	0	0	0	0	0	0	0	0
B3H	Timer 0 Counter Register	T0CNT	R	0	0	0	0	0	0	0	0
B4H	Timer 0 Data Register	T0DR	R/W	1	1	1	1	1	1	1	1
	Timer 0 Capture Data Register	T0CDR	R	0	0	0	0	0	0	0	0
B5H	SIO Control Register	SIOCR	R/W	0	0	0	0	0	0	0	0
B6H	SIO Data Register	SIODR	R/W	0	0	0	0	0	0	0	0
B7H	SIO Pre-scale Register	SIOPS	R/W	0	0	0	0	0	0	0	0
B8H	Interrupt Priority Register	IP	R/W	–	–	0	0	0	0	0	0
B9H	P5 Direction Register	P5IO	R/W	0	0	0	0	0	0	0	0
BAH	Timer 2 Control Register	T2CR	R/W	0	–	–	0	0	0	0	0
BBH	P6 Open-drain Selection Register	P6OD	R/W	0	0	0	0	0	0	0	0
BCH	Timer 2 Counter Low Register	T2CNTL	R	0	0	0	0	0	0	0	0
BDH	Timer 2 Counter High Register	T2CNTH	R	0	0	0	0	0	0	0	0
BEH	Timer 2 Data Low Register	T2DRL	R/W	1	1	1	1	1	1	1	1
BFH	Timer 2 Data High Register	T2DRH	R/W	1	1	1	1	1	1	1	1

Table 8-2. SFR Map (Continued)

Address	Function	Symbol	R/W	@Reset								
				7	6	5	4	3	2	1	0	
C0H	P6 Data Register	P6	R/W	0	0	0	0	0	0	0	0	0
C1H	P6 Direction Register	P6IO	R/W	0	0	0	0	0	0	0	0	0
C2H	Timer 3 Control Register	T3CR	R/W	0	0	0	0	0	0	0	0	0
C3H	Timer Interrupt Flag Register	TIFR	R/W	0	–	0	0	0	0	0	0	0
C4H	Timer 3 Counter Low Register	T3CNTL	R	0	0	0	0	0	0	0	0	0
C5H	Timer 3 Counter High Register	T3CNTH	R	0	0	0	0	0	0	0	0	0
C6H	Timer 3 Data Low Register	T3DRL	R/W	1	1	1	1	1	1	1	1	1
	Timer 3 Capture Data Low Register	T3CDRL	R	0	0	0	0	0	0	0	0	0
C7H	Timer 3 Data High Register	T3DRH	R/W	1	1	1	1	1	1	1	1	1
	Timer 3 Capture Data High Register	T3CDRH	R	0	0	0	0	0	0	0	0	0
C8H	P7 Data Register	P7	R/W	–	–	–	0	0	0	–	–	–
C9H	P7 Direction Register	P7IO	R/W	–	–	–	0	0	0	–	–	–
CAH	Timer 1 Control Register	T1CR	R/W	0	–	0	0	0	0	0	0	0
CBH	Timer 1 Counter Register	T1CNT	R	0	0	0	0	0	0	0	0	0
CCH	Timer 1 Data Low Register	T1DRL	R/W	1	1	1	1	1	1	1	1	1
CDH	Timer 1 Data High Register	T1DRH	R/W	1	1	1	1	1	1	1	1	1
CEH	Carrier Control Register	CARCR	R/W	–	–	0	0	–	–	0	0	0
CFH	P7 Open-drain Selection Register	P7OD	R/W	–	–	–	0	0	0	–	–	–
D0H	Program Status Word Register	PSW	R/W	0	0	0	0	0	0	0	0	0
D1H	P8 Direction Register	P8IO	R/W	1	1	1	–	–	–	–	–	–
D2H	P8 Open-drain Selection Register	P8OD	R/W	1	1	1	–	–	–	–	–	–
D3H	Reserved	–	–	–								
D4H	P0 Pull-up Resistor Selection Register	P0PU	R/W	–	–	0	0	0	0	0	0	0
D5H	P1 Pull-up Resistor Selection Register	P1PU	R/W	–	0	0	0	–	0	0	0	0
D6H	P2 Pull-up Resistor Selection Register	P2PU	R/W	–	–	–	0	0	0	0	0	0
D7H	P3 Pull-up Resistor Selection Register	P3PU	R/W	–	0	0	0	0	0	0	0	–
D8H	P8 Data Register	P8	R/W	1	1	1	–	–	–	–	–	–
D9H	Oscillator Control Register	OSCCR	R/W	–	–	–	0	0	0	0	0	0
DAH	P4 Pull-up Resistor Selection Register	P4PU	R/W	0	0	0	0	0	0	0	0	0
DBH	P5 Pull-up Resistor Selection Register	P5PU	R/W	0	0	0	0	0	0	0	0	0
DCH	P6 Pull-up Resistor Selection Register	P6PU	R/W	0	0	0	0	0	0	0	0	0
DDH	P7 Pull-up Resistor Selection Register	P7PU	R/W	–	–	–	0	0	0	–	–	–
DEH	P8 Pull-up Resistor Selection Register	P8PU	R/W	0	0	0	–	–	–	–	–	–
DFH	Reserved	–	–	–								

Table 8-3. SFR Map (Continued)

Address	Function	Symbol	R/W	@Reset								
				7	6	5	4	3	2	1	0	
E0H	Accumulator Register	ACC	R/W	0	0	0	0	0	0	0	0	0
E1H	Low Voltage Indicator Control Register	LVICR	R/W	0	–	0	0	0	0	0	0	0
E2H	UART Control Register 1	UARTCR1	R/W	–	0	0	0	0	0	0	0	0
E3H	UART Control Register 2	UARTCR2	R/W	0	0	0	0	0	0	0	0	0
E4H	UART Control Register 3	UARTCR3	R/W	0	0	0	–	–	0	0	0	0
E5H	UART Status Register	UARTST	R/W	1	0	0	0	0	0	0	0	0
E6H	UART Baud Rate Generation Register	UARTBD	R/W	1	1	1	1	1	1	1	1	1
E7H	UART Data Register	UARTDR	R/W	0	0	0	0	0	0	0	0	0
E8H	P9 Control and Data Register	P9CDR	R/W	–	–	–	–	0	0	0	0	0
E9H	P0 De-bounce Enable Register	P0DB	R/W	–	–	0	0	0	0	0	0	0
EAH	P1 De-bounce Enable Register	P1DB	R/W	0	0	0	–	–	0	–	–	–
EBH	LCD Driver Control Low Register	LCDCRL	R/W	–	–	–	–	–	–	–	0	0
ECH	LCD Driver Control High Register	LCDCRH	R/W	0	0	0	0	0	0	0	0	0
EDH	Port Function Selection Register 0	PFSR0	R/W	0	0	0	–	–	0	0	0	0
EEH	Port Function Selection Register 1	PFSR1	R/W	–	–	0	0	0	0	0	0	0
EFH	Port Function Selection Register 2	PFSR2	R/W	0	0	0	0	0	0	–	–	–
F0H	B Register	B	R/W	0	0	0	0	0	0	0	0	0
F1H	Port Function Selection Register 3	PFSR3	R/W	0	0	0	0	0	0	0	0	0
F2H	Port Function Selection Register 4	PFSR4	R/W	0	0	0	0	0	0	0	0	0
F3H	Port Function Selection Register 5	PFSR5	R/W	0	0	–	–	0	0	0	0	0
F4H	Port Function Selection Register 6	PFSR6	R/W	–	–	–	–	0	0	0	0	0
F5H	Reserved	–	–	–								
F6H	Port Function Selection Register 8	PFSR8	R/W	0	0	0	0	0	0	–	–	–
F7H	Low Voltage Reset Control Register	LVRCR	R/W	0	–	–	0	0	0	0	0	0
F8H	Interrupt Priority Register 1	IP1	R/W	–	–	0	0	0	0	0	0	0
F9H	Reserved	–	–	–								
FAH	Flash Sector Address High Register	FSADRH	R/W	–	–	–	–	0	0	0	0	0
FBH	Flash Sector Address Middle Register	FSADRM	R/W	0	0	0	0	0	0	0	0	0
FCH	Flash Sector Address Low Register	FSADRL	R/W	0	0	0	0	0	0	0	0	0
FDH	Flash Identification Register	FIDR	R/W	0	0	0	0	0	0	0	0	0
FEH	Flash Mode Control Register	FMCR	R/W	0	–	–	–	–	0	0	0	0
FFH	Reserved	–	–	–								

Table 8-4. SFR Map (Continued)

8.4.3 Compiler Compatible SFR

ACC (Accumulator Register) : E0H

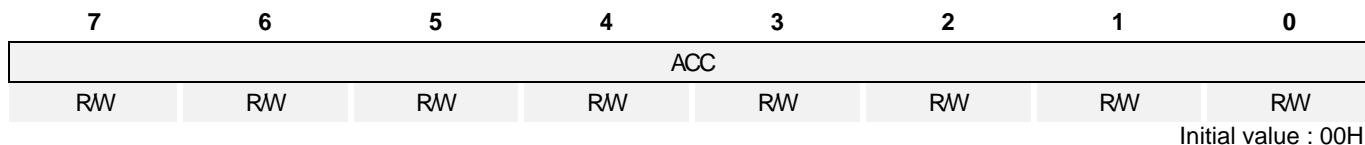

ACC Accumulator

B (B Register) : F0H

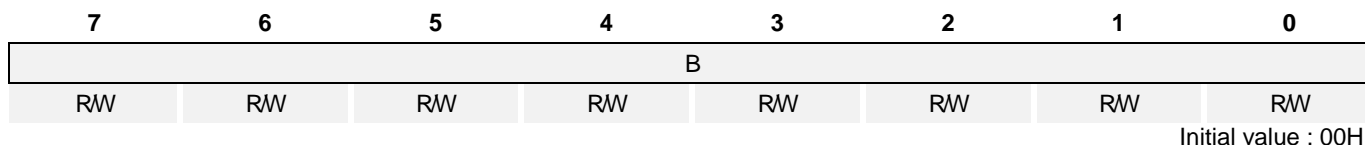

B B Register

SP (Stack Pointer) : 81H

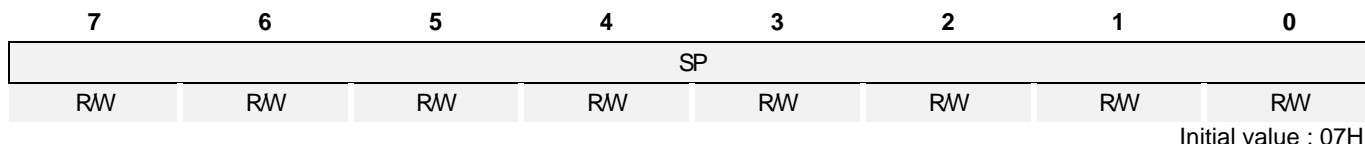

SP Stack Pointer

DPL (Data Pointer Register Low) : 82H

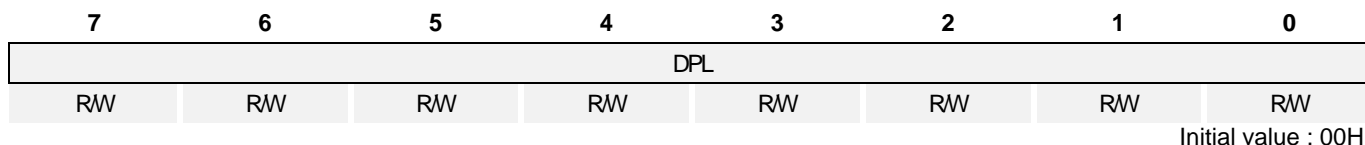

DPL Data Pointer Low

DPH (Data Pointer Register High) : 83H

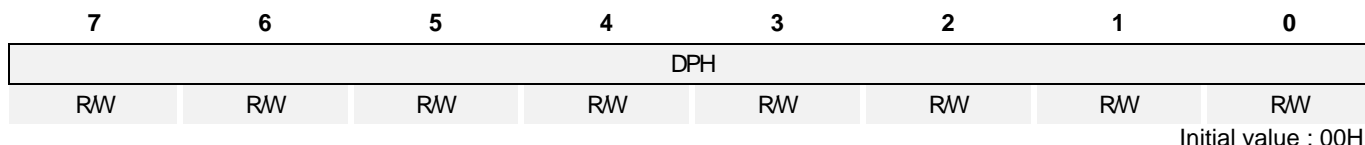

DPH Data Pointer High

DPL1 (Data Pointer Register Low 1) : 84H

7	6	5	4	3	2	1	0
DPL1							
RW	RW	RW	RW	RW	RW	RW	RW

Initial value : 00H

DPL1 Data Pointer Low 1

DPH1 (Data Pointer Register High 1) : 85H

7	6	5	4	3	2	1	0
DPH1							
RW	RW	RW	RW	RW	RW	RW	RW

Initial value : 00H

DPH1 Data Pointer High 1

PSW (Program Status Word Register) : D0H

7	6	5	4	3	2	1	0
CY	AC	F0	RS1	RS0	OV	F1	P
RW	RW	RW	RW	RW	RW	RW	RW

Initial value : 00H

- CY** Carry Flag
- AC** Auxiliary Carry Flag
- F0** General Purpose User-Definable Flag
- RS1** Register Bank Select bit 1
- RS0** Register Bank Select bit 0
- OV** Overflow Flag
- F1** User-Definable Flag
- P** Parity Flag. Set/cleared by hardware each instruction cycle to indicate an odd/even number of '1' bits in the accumulator

EO (Extended Operation Register) : A2H

7	6	5	4	3	2	1	0
-	-	-	TRAP_EN	-	DPSEL2	DPSEL1	DPSEL0
-	-	-	RW	-	RW	RW	RW

Initial value : 00H

- TRAP_EN** Select the Instruction (**Keep always '0'**).
 - 0 Select MOV_C @(DPTR++), A
 - 1 Select Software TRAP Instruction
- DPSEL[2:0]** Select Banked Data Pointer Register

DPSEL2	DPSEL1	DPSEL0	Description
0	0	0	DPTR0
0	0	1	DPTR1
Reserved			

9 I/O Ports

9.1 I/O Ports

The MC96F6632S has ten groups of I/O ports (P0 ~ P9). Each port can be easily configured by software as I/O pin, internal pull up and open-drain pin to meet various system configurations and design requirements. Also P0, P1 and P8 includes function that can generate interrupt according to change of state of the pin.

9.2 Port Register

9.2.1 Data Register (Px)

Data Register is a bidirectional I/O port. If ports are configured as output ports, data can be written to the corresponding bit of the Px. If ports are configured as input ports, the data can be read from the corresponding bit of the Px.

9.2.2 Direction Register (PxIO)

Each I/O pin can be independently used as an input or an output through the PxIO register. Bits cleared in this register will make the corresponding pin of Px to input mode. Set bits of this register will make the pin to output mode. Almost bits are cleared by a system reset, but some bits are set by a system reset.

9.2.3 Pull-up Resistor Selection Register (PxPU)

The on-chip pull-up resistor can be connected to I/O ports individually with a pull-up resistor selection register (PxPU). The pull-up register selection controls the pull-up resistor enable/disable of each port. When the corresponding bit is 1, the pull-up resistor of the pin is enabled. When 0, the pull-up resistor is disabled. All bits are cleared by a system reset.

9.2.4 Open-drain Selection Register (PxOD)

There are internally open-drain selection registers (PxOD) for P0 ~ P8 and a bit for P9. The open-drain selection register controls the open-drain enable/disable of each port. Almost ports become push-pull by a system reset, but some ports become open-drain by a system reset.

9.2.5 De-bounce Enable Register (PxDB)

P0[5:0], P12, and P85 support debounce function. Debounce clocks of each ports are $fx/1$, $fx/4$, and $fx/4096$.

9.2.6 P9 Control and Data Register (P9CDR)

P9 I/O pin can be independently used as an input or an output through the P92IO. Clearing the bit will make the pin in P92 to input mode, setting the bit will make the pin to output mode. P92 is a bidirectional I/O port. If P92 port is configured as an output port, data can be written to the corresponding bit of the P92. If P92 port is configured as an input port, the data can be read from the corresponding bit of the P92. The P92PU controls the pull-up resistor enable/disable of P92 port. The P92OD controls the open-drain enable/disable of P92 port. All bits in the P9CDR register are cleared by a system reset.

9.2.7 Port Function Selection Register (PFSRx)

These registers define alternative functions of ports. Please remember that these registers should be set properly for alternative port function. A reset clears the PFSRx register to '00H', which makes all pins to normal I/O ports.

9.2.8 Register Map

Name	Address	Dir	Default	Description
P0	80H	R/W	00H	P0 Data Register
P0IO	89H	R/W	00H	P0 Direction Register
P0PU	D4H	R/W	00H	P0 Pull-up Resistor Selection Register
P0OD	92H	R/W	00H	P0 Open-drain Selection Register
P0DB	E9H	R/W	00H	P0 De-bounce Enable Register
P1	88H	R/W	00H	P1 Data Register
P1IO	91H	R/W	00H	P1 Direction Register
P1PU	D5H	R/W	00H	P1 Pull-up Resistor Selection Register
P1OD	93H	R/W	00H	P1 Open-drain Selection Register
P1DB	EAH	R/W	00H	P1 De-bounce Enable Register
P2	90H	R/W	18H	P2 Data Register
P2IO	99H	R/W	18H	P2 Direction Register
P2PU	D6H	R/W	00H	P2 Pull-up Resistor Selection Register
P2OD	94H	R/W	18H	P2 Open-drain Selection Register
P3	98H	R/W	00H	P3 Data Register
P3IO	A1H	R/W	00H	P3 Direction Register
P3PU	D7H	R/W	00H	P3 Pull-up Resistor Selection Register
P3OD	95H	R/W	00H	P3 Open-drain Selection Register
P4	A0H	R/W	00H	P4 Data Register
P4IO	B1H	R/W	00H	P4 Direction Register
P4PU	DAH	R/W	00H	P4 Pull-up Resistor Selection Register
P4OD	96H	R/W	00H	P4 Open-drain Selection Register
P5	B0H	R/W	00H	P5 Data Register
P5IO	B9H	R/W	00H	P5 Direction Register
P5PU	DBH	R/W	00H	P5 Pull-up Resistor Selection Register
P5OD	A7H	R/W	00H	P5 Open-drain Selection Register
P6	C0H	R/W	00H	P6 Data Register
P6IO	C1H	R/W	00H	P6 Direction Register
P6PU	DCH	R/W	00H	P6 Pull-up Resistor Selection Register
P6OD	BBH	R/W	00H	P6 Open-drain Selection Register

Table 9-1. Port Register Map

Name	Address	Dir	Default	Description
P7	C8H	R/W	00H	P7 Data Register
P7IO	C9H	R/W	00H	P7 Direction Register
P7PU	DDH	R/W	00H	P7 Pull-up Resistor Selection Register
P7OD	CFH	R/W	00H	P7 Open-drain Selection Register
P8	D8H	R/W	E0H	P8 Data Register
P8IO	D1H	R/W	E0H	P8 Direction Register
P8PU	DEH	R/W	00H	P8 Pull-up Resistor Selection Register
P8OD	D2H	R/W	E0H	P8 Open-drain Selection Register
P9CDR	E8H	R/W	00H	P9 Control and Data Register
PFSR0	EDH	R/W	00H	Port Function Selection Register 0
PFSR1	EEH	R/W	00H	Port Function Selection Register 1
PFSR2	EFH	R/W	00H	Port Function Selection Register 2
PFSR3	F1H	R/W	00H	Port Function Selection Register 3
PFSR4	F2H	R/W	00H	Port Function Selection Register 4
PFSR5	F3H	R/W	00H	Port Function Selection Register 5
PFSR6	F4H	R/W	00H	Port Function Selection Register 6
PFSR8	F6H	R/W	00H	Port Function Selection Register 8

Table 9-2. Register Map (Continued)

9.3 P0 Port

9.3.1 P0 Port Description

P0 is 6-bit I/O port. P0 control registers consist of P0 data register (P0), P0 direction register (P0IO), debounce enable register (P0DB), P0 pull-up resistor selection register (P0PU), and P0 open-drain selection register (P0OD). The P05 function can be selected by the PFSR0[1:0] bits of the PFSR0 register. Refer to the port function selection registers.

9.3.2 Register description for P0

P0 (P0 Data Register) : 80H

7	6	5	4	3	2	1	0
–	–	P05	P04	P03	P02	P01	P00
–	–	RW	RW	RW	RW	RW	RW

Initial value : 00H

P0[5:0] I/O Data

P0IO (P0 Direction Register) : 89H

7	6	5	4	3	2	1	0
–	–	P05IO	P04IO	P03IO	P02IO	P01IO	P00IO
–	–	RW	RW	RW	RW	RW	RW

Initial value : 00H

P0IO[5:0] P0 Data I/O Direction.
 0 Input
 1 Output

NOTE)

1. EINT0 ~ EINT5 function possible when input

P0PU (P0 Pull-up Resistor Selection Register) : D4H

7	6	5	4	3	2	1	0
–	–	P05PU	P04PU	P03PU	P02PU	P01PU	P00PU
–	–	RW	RW	RW	RW	RW	RW

Initial value : 00H

P0PU[5:0] Configure Pull-up Resistor of P0 Port
 0 Disable
 1 Enable

P0OD (P0 Open-drain Selection Register) : 92H

7	6	5	4	3	2	1	0
–	–	P05OD	P04OD	P03OD	P02OD	P01OD	P00OD
–	–	RW	RW	RW	RW	RW	RW

Initial value : 00H

P0OD[5:0] Configure Open-drain of P0 Port
 0 Push-pull output
 1 Open-drain output

P0DB (P0 De-bounce Enable Register): E9H

7	6	5	4	3	2	1	0
–	–	P05DB	P04DB	P03DB	P02DB	P01DB	P00DB
–	–	RW	RW	RW	RW	RW	RW

Initial value: 00H

P0DB[5:0] Configure De-bounce of P0 Port
 0 Disable
 1 Enable

NOTE)

1. If the same level is not detected on enabled pin three or four times in a row at the sampling clock, the signal is eliminated as noise.
2. A pulse level should be input for the duration of 3 clock or more to be actually detected as a valid edge.
3. The port de-bounce is automatically disabled at stop mode and recovered after stop mode release.
4. Refer to the port 1 de-bounce enable register (P1DB) for the de-bounce clock of port 0.

9.4 P1 Port

9.4.1 P1 Port Description

P1 is 6-bit I/O port. P1 control registers consist of P1 data register (P1), P1 direction register (P1IO), debounce enable register (P1DB), P1 pull-up resistor selection register (P1PU), and P1 open-drain selection register (P1OD) . Refer to the port function selection registers for the P1 function selection.

9.4.2 Register description for P1

P1 (P1 Data Register) : 88H

7	6	5	4	3	2	1	0
–	P16	P15	P14	–	P12	P11	P10
–	RW	RW	RW	–	RW	RW	RW

Initial value : 00H

P1[6:4] I/O Data
P1[2:0]

P1IO (P1 Direction Register) : 91H

7	6	5	4	3	2	1	0
–	P16IO	P15IO	P14IO	–	P12IO	P11IO	P10IO
–	RW	RW	RW	–	RW	RW	RW

Initial value : 00H

P1IO[6:4] P1 Data I/O Direction
P1IO[2:0] 0 Input
 1 Output

NOTE)

1. EINT13 function possible when input

P1PU (P1 Pull-up Resistor Selection Register) : D5H

7	6	5	4	3	2	1	0
–	P16PU	P15PU	P14PU	–	P12PU	P11PU	P10PU
–	RW	RW	RW	–	RW	RW	RW

Initial value : 00H

P1PU[6:4] Configure Pull-up Resistor of P1 Port
P1PU[2:0] 0 Disable
 1 Enable

P1OD (P1 Open-drain Selection Register) : 93H

7	6	5	4	3	2	1	0
–	P16OD	P15OD	P14OD	–	P12OD	P11OD	P10OD
–	RW	RW	RW	–	RW	RW	RW

Initial value : 00H

P1OD[6:4] Configure Open-drain of P1 Port
P1OD[2:0] 0 Push-pull output
 1 Open-drain output

P1DB (P1 De-bounce Enable Register) : EAH

7	6	5	4	3	2	1	0
DBCLK1	DBCLK0	P85DB	-	-	P12DB	-	-
RW	RW	RW	-	-	RW	-	-

Initial value : 00H

DBCLK[1:0] Configure De-bounce Clock of Port

DBCLK1	DBCLK0	Description
0	0	fx/1
0	1	fx/4
1	0	fx/4096
1	1	Reserved

P85DB Configure De-bounce of P85 Port

0	Disable
1	Enable

P12DB Configure De-bounce of P12 Port

0	Disable
1	Enable

NOTE)

1. If the same level is not detected on enabled pin three or four times in a row at the sampling clock, the signal is eliminated as noise.
2. A pulse level should be input for the duration of 3 clock or more to be actually detected as a valid edge.
3. The port de-bounce is automatically disabled at stop mode and recovered after stop mode release.

9.5 P2 Port

9.5.1 P2 Port Description

P2 is 5-bit I/O port. P2 control registers consist of P2 data register (P2), P2 direction register (P2IO), P2 pull-up resistor selection register (P2PU) and P2 open-drain selection register (P2OD). Refer to the port function selection registers for the P2 function selection.

9.5.2 Register description for P2

P2 (P2 Data Register) : 90H

7	6	5	4	3	2	1	0
–	–	–	P24	P23	P22	P21	P20
–	–	–	R/W	R/W	R/W	R/W	R/W

Initial value : 18H

P2[4:0] I/O Data

P2IO (P2 Direction Register) : 99H

7	6	5	4	3	2	1	0
–	–	–	P24IO	P23IO	P22IO	P21IO	P20IO
–	–	–	R/W	R/W	R/W	R/W	R/W

Initial value : 18H

P2IO[4:0] P2 Data I/O Direction
 0 Input
 1 Output

P2PU (P2 Pull-up Resistor Selection Register) : D6H

7	6	5	4	3	2	1	0
–	–	–	P24PU	P23PU	P22PU	P21PU	P20PU
–	–	–	R/W	R/W	R/W	R/W	R/W

Initial value : 00H

P2PU[4:0] Configure Pull-up Resistor of P2 Port
 0 Disable
 1 Enable

P2OD (P2 Open-drain Selection Register) : 94H

7	6	5	4	3	2	1	0
–	–	–	P24OD	P23OD	P22OD	P21OD	P20OD
–	–	–	R/W	R/W	R/W	R/W	R/W

Initial value : 18H

P2OD[4:0] Configure Open-drain of P2 Port
 0 Push-pull output
 1 Open-drain output

9.6 P3 Port

9.6.1 P3 Port Description

P3 is 6-bit I/O port. P3 control registers consist of P3 data register (P3), P3 direction register (P3IO), P3 pull-up resistor selection register (P3PU) and P3 open-drain selection register (P3OD). Refer to the port function selection registers for the P3 function selection.

9.6.2 Register description for P3

P3 (P3 Data Register) : 98H

7	6	5	4	3	2	1	0
–	P36	P35	P34	P33	P32	P31	–
–	R/W	R/W	R/W	R/W	R/W	R/W	–

Initial value : 00H

P3[6:1] I/O Data

P3IO (P3 Direction Register) : A1H

7	6	5	4	3	2	1	0
–	P36IO	P35IO	P34IO	P33IO	P32IO	P31IO	–
–	R/W	R/W	R/W	R/W	R/W	R/W	–

Initial value : 00H

P3IO[6:1] P3 Data I/O Direction
 0 Input
 1 Output

P3PU (P3 Pull-up Resistor Selection Register) : D7H

7	6	5	4	3	2	1	0
–	P36PU	P35PU	P34PU	P33PU	P32PU	P31PU	–
–	R/W	R/W	R/W	R/W	R/W	R/W	–

Initial value : 00H

P3PU[6:1] Configure Pull-up Resistor of P3 Port
 0 Disable
 1 Enable

P3OD (P3 Open-drain Selection Register) : 95H

7	6	5	4	3	2	1	0
–	P36OD	P35OD	P34OD	P33OD	P32OD	P31OD	–
–	R/W	R/W	R/W	R/W	R/W	R/W	–

Initial value : 00H

P3OD[6:1] Configure Open-drain of P3 Port
 0 Push-pull output
 1 Open-drain output

9.7 P4 Port

9.7.1 P4 Port Description

P4 is 8-bit I/O port. P4 control registers consist of P4 data register (P4), P4 direction register (P4IO), P4 pull-up resistor selection register (P4PU) and P4 open-drain selection register (P4OD). Refer to the port function selection registers for the P4 function selection.

9.7.2 Register description for P4

P4 (P4 Data Register) : A0H

7	6	5	4	3	2	1	0
P47	P46	P45	P44	P43	P42	P41	P40
RW	RW	RW	RW	RW	RW	RW	RW

Initial value : 00H

P4[7:0] I/O Data

P4IO (P4 Direction Register) : B1H

7	6	5	4	3	2	1	0
P47IO	P46IO	P45IO	P44IO	P43IO	P42IO	P41IO	P40IO
RW	RW	RW	RW	RW	RW	RW	RW

Initial value : 00H

P4IO[7:0] P4 Data I/O Direction

0 Input

1 Output

P4PU (P4 Pull-up Resistor Selection Register) : DAH

7	6	5	4	3	2	1	0
P47PU	P46PU	P45PU	P44PU	P43PU	P42PU	P41PU	P40PU
RW	RW	RW	RW	RW	RW	RW	RW

Initial value : 00H

P4PU[7:0] Configure Pull-up Resistor of P4 Port

0 Disable

1 Enable

P4OD (P4 Open-drain Selection Register) : 96H

7	6	5	4	3	2	1	0
P47OD	P46OD	P45OD	P44OD	P43OD	P42OD	P41OD	P40OD
RW	RW	RW	RW	RW	RW	RW	RW

Initial value : 00H

P4OD[7:0] Configure Open-drain of P4 Port

0 Push-pull output

1 Open-drain output

9.8 P5 Port

9.8.1 P5 Port Description

P5 is 8-bit I/O port. P5 control registers consist of P5 data register (P5), P5 direction register (P5IO), P5 pull-up resistor selection register (P5PU) and P5 open-drain selection register (P5OD). Refer to the port function selection registers for the P5 function selection.

9.8.2 Register description for P5

P5 (P5 Data Register) : B0H

7	6	5	4	3	2	1	0
P57	P56	P55	P54	P53	P52	P51	P50
RW	RW	RW	RW	RW	RW	RW	RW

Initial value : 00H

P5[7:0] I/O Data

P5IO (P5 Direction Register) : B9H

7	6	5	4	3	2	1	0
P57IO	P56IO	P55IO	P54IO	P53IO	P52IO	P51IO	P50IO
RW	RW	RW	RW	RW	RW	RW	RW

Initial value : 00H

P5IO[7:0] P5 Data I/O Direction
 0 Input
 1 Output

P5PU (P5 Pull-up Resistor Selection Register) : DBH

7	6	5	4	3	2	1	0
P57PU	P56PU	P55PU	P54PU	P53PU	P52PU	P51PU	P50PU
RW	RW	RW	RW	RW	RW	RW	RW

Initial value : 00H

P5PU[7:0] Configure Pull-up Resistor of P5 Port
 0 Disable
 1 Enable

P5OD (P5 Open-drain Selection Register) : A7H

7	6	5	4	3	2	1	0
P57OD	P56OD	P55OD	P54OD	P53OD	P52OD	P51OD	P50OD
RW	RW	RW	RW	RW	RW	RW	RW

Initial value : 00H

P5OD[7:0] Configure Open-drain of P5 Port
 0 Push-pull output
 1 Open-drain output

9.9 P6 Port

9.9.1 P6 Port Description

P6 is 8-bit I/O port. P6 control registers consist of P6 data register (P6), P6 direction register (P6IO), P6 pull-up resistor selection register (P6PU) and P6 open-drain selection register (P6OD). Refer to the port function selection registers for the P6 function selection.

9.9.2 Register description for P6

P6 (P6 Data Register) : C0H

7	6	5	4	3	2	1	0
P67	P66	P65	P64	P63	P62	P61	P60
RW	RW	RW	RW	RW	RW	RW	RW

Initial value : 00H

P6[7:0] I/O Data

P6IO (P6 Direction Register) : C1H

7	6	5	4	3	2	1	0
P67IO	P66IO	P65IO	P64IO	P63IO	P62IO	P61IO	P60IO
RW	RW	RW	RW	RW	RW	RW	RW

Initial value : 00H

P6IO[7:0] P6 Data I/O Direction

0 Input

1 Output

P6PU (P6 Pull-up Resistor Selection Register) : DCH

7	6	5	4	3	2	1	0
P67PU	P66PU	P65PU	P64PU	P63PU	P62PU	P61PU	P60PU
RW	RW	RW	RW	RW	RW	RW	RW

Initial value : 00H

P6PU[7:0] Configure Pull-up Resistor of P6 Port

0 Disable

1 Enable

P6OD (P6 Open-drain Selection Register) : BBH

7	6	5	4	3	2	1	0
P67OD	P66OD	P65OD	P64OD	P63OD	P62OD	P61OD	P60OD
RW	RW	RW	RW	RW	RW	RW	RW

Initial value : 00H

P6OD[7:0] Configure Open-drain of P6 Port

0 Push-pull output

1 Open-drain output

9.10 P7 Port

9.10.1 P7 Port Description

P7 is 3-bit I/O port. P7 control registers consist of P7 data register (P7), P7 direction register (P7IO), P7 pull-up resistor selection register (P7PU) and P7 open-drain selection register (P7OD). Refer to the port function selection registers for the P7 function selection.

9.10.2 Register description for P7

P7 (P7 Data Register) : C8H

7	6	5	4	3	2	1	0
–	–	–	P74	P73	P72	–	–
–	–	–	R/W	R/W	R/W	–	–

Initial value : 00H

P7[4:2] I/O Data

P7IO (P7 Direction Register) : C9H

7	6	5	4	3	2	1	0
–	–	–	P74IO	P73IO	P72IO	–	–
–	–	–	R/W	R/W	R/W	–	–

Initial value : 00H

P7IO[4:2] P7 Data I/O Direction
 0 Input
 1 Output

P7PU (P7 Pull-up Resistor Selection Register) : DDH

7	6	5	4	3	2	1	0
–	–	–	P74PU	P73PU	P72PU	–	–
–	–	–	R/W	R/W	R/W	–	–

Initial value : 00H

P7PU[4:2] Configure Pull-up Resistor of P7 Port
 0 Disable
 1 Enable

P7OD (P7 Open-drain Selection Register) : CFH

7	6	5	4	3	2	1	0
–	–	–	P74OD	P73OD	P72OD	–	–
–	–	–	R/W	R/W	R/W	–	–

Initial value : 00H

P7OD[4:2] Configure Open-drain of P7 Port
 0 Push-pull output
 1 Open-drain output

9.11 P8 Port

9.11.1 P8 Port Description

P8 is 3-bit I/O port. P8 control registers consist of P8 data register (P8), P8 direction register (P8IO), P8 pull-up resistor selection register (P8PU) and P8 open-drain selection register (P8OD). Refer to the port function selection registers for the P8 function selection.

9.11.2 Register description for P8

P8 (P8 Data Register) : D8H

7	6	5	4	3	2	1	0
P87	P86	P85	–	–	–	–	–
RW	RW	RW	–	–	–	–	–

Initial value : E0H

P8[7:5] I/O Data

P8IO (P8 Direction Register) : D1H

7	6	5	4	3	2	1	0
P87IO	P86IO	P85IO	–	–	–	–	–
RW	RW	RW	–	–	–	–	–

Initial value : E0H

P8IO[7:5] P8 Data I/O Direction
 0 Input
 1 Output

NOTE)

- EINT10 function possible when input

P8PU (P8 Pull-up Resistor Selection Register) : DEH

7	6	5	4	3	2	1	0
P87PU	P86PU	P85PU	–	–	–	–	–
RW	RW	RW	–	–	–	–	–

Initial value : 00H

P8PU[7:5] Configure Pull-up Resistor of P8 Port
 0 Disable
 1 Enable

P8OD (P8 Open-drain Selection Register) : D2H

7	6	5	4	3	2	1	0
P87OD	P86OD	P85OD	–	–	–	–	–
RW	RW	RW	–	–	–	–	–

Initial value : E0H

P8OD[7:5] Configure Open-drain of P8 Port
 0 Push-pull output
 1 Open-drain output

9.12 P9 Port

9.12.1 P9 Port Description

P9 is 1-bit I/O port. P9 control registers consist of P9 control and data register (P9CDR).

9.12.2 Register description for P9

P9CDR (P9 Control and Data Register) : E8H

7	6	5	4	3	2	1	0
–	–	–	–	P92OD	P92PU	P92IO	P92
–	–	–	–	RW	RW	RW	RW

Initial value : 00H

P92OD	Configure Open-drain of P9 Port
0	Disable
1	Enable
P92PU	Configure Pull-up Resistor of P9 Port
0	Disable
1	Enable
P92IO	P9 Data I/O Direction
0	Input
1	Output
P92	I/O Data

9.13 Port Function

9.13.1 Port Function Description

Port function control registers consist of Port function selection register 0 ~ 8. (PFSR0 ~ PFSR8).

9.13.2 Register description for PFSR0 ~ PFSR8

PFSR0 (Port Function Selection Register 0) : EDH

7	6	5	4	3	2	1	0
PFSR07	PFSR06	PFSR05	–	–	PFSR02	PFSR01	PFSR00
RW	RW	RW	–	–	RW	RW	RW

Initial value : 00H

PFSR0[7:6]	P15 Function Select	
	PFSR07	PFSR06
	Description	
	0	0
	Port	
	0	1
	SCK-in Function	
	1	0
	SCK-out Function	
	1	1
	Not used	
PFSR05	P14 Function select	
	0	Port
	1	SO Function
PFSR02	P12 Function Select	
	0	Port (EINT13 function possible when input)
	1	PWM3O/T3O Function
PFSR0[1:0]	P05 Function Select	
	PFSR01	PFSR00
	Description	
	0	0
	Port	
	0	1
	BUZO Function	
	1	0
	EC3 Function	
	1	1
	Not used	

PFSR1 (Port Function Selection Register 1) : EEH

7	6	5	4	3	2	1	0
–	–	PFSR15	PFSR14	PFSR13	PFSR12	PFSR11	PFSR10
–	–	RW	RW	RW	RW	RW	RW

Initial value : 00H

PFSR15	P24 Function select
	0 Port
	1 AN4 Function
PFSR14	P23 Function Select
	0 Port
	1 AN3 Function
PFSR13	P22 Function select
	0 Port
	1 AN2 Function
PFSR12	P21 Function Select
	0 Port
	1 AN1 Function
PFSR11	P20 Function select
	0 Port
	1 AN0 Function
PFSR10	P16 Function Select
	0 Port
	1 SI Function

PFSR2 (Port Function Selection Register 2) : EFH

7	6	5	4	3	2	1	0
PFSR27	PFSR26	PFSR25	PFSR24	PFSR23	PFSR22	–	–
RW	RW	RW	RW	RW	RW	–	–

Initial value : 00H

- PFSR27 P43 Function select
 - 0 Port
 - 1 COM5/SEG3 Function
- PFSR26 P42 Function Select
 - 0 Port
 - 1 COM4/SEG2 Function
- PFSR25 P41 Function select
 - 0 Port
 - 1 COM3/SEG1 Function
- PFSR24 P40 Function Select
 - 0 Port
 - 1 COM2/SEG0 Function
- PFSR23 P36 Function select
 - 0 Port
 - 1 COM1 Function
- PFSR22 P35 Function Select
 - 0 Port
 - 1 COM0 Function

PFSR3 (Port Function Selection Register 3) : F1H

7	6	5	4	3	2	1	0
PFSR37	PFSR36	PFSR35	PFSR34	PFSR33	PFSR32	PFSR31	PFSR30
RW	RW	RW	RW	RW	RW	RW	RW

Initial value : 00H

- PFSR37 P53 Function select
 - 0 Port
 - 1 SEG11 Function
- PFSR36 P52 Function Select
 - 0 Port
 - 1 SEG10 Function
- PFSR35 P51 Function select
 - 0 Port
 - 1 SEG9 Function
- PFSR34 P50 Function Select
 - 0 Port
 - 1 SEG8 Function
- PFSR33 P47 Function select
 - 0 Port
 - 1 SEG7 Function
- PFSR32 P46 Function Select
 - 0 Port
 - 1 SEG6 Function
- PFSR31 P45 Function select
 - 0 Port
 - 1 COM7/SEG5 Function
- PFSR30 P44 Function Select
 - 0 Port
 - 1 COM6/SEG4 Function

PFSR4 (Port Function Selection Register 4) : F2H

7	6	5	4	3	2	1	0
PFSR47	PFSR46	PFSR45	PFSR44	PFSR43	PFSR42	PFSR41	PFSR40
RW	RW	RW	RW	RW	RW	RW	RW

Initial value : 00H

- PFSR47 P63 Function select
 - 0 Port
 - 1 SEG19 Function
- PFSR46 P62 Function Select
 - 0 Port
 - 1 SEG18 Function
- PFSR45 P61 Function select
 - 0 Port
 - 1 SEG17 Function
- PFSR44 P60 Function Select
 - 0 Port
 - 1 SEG16 Function
- PFSR43 P57 Function select
 - 0 Port
 - 1 SEG15 Function
- PFSR42 P56 Function Select
 - 0 Port
 - 1 SEG14 Function
- PFSR41 P55 Function select
 - 0 Port
 - 1 SEG13 Function
- PFSR40 P54 Function Select
 - 0 Port
 - 1 SEG12 Function

PFSR5 (Port Function Selection Register 5) : F3H

7	6	5	4	3	2	1	0
PFSR57	PFSR56	–	–	PFSR53	PFSR52	PFSR51	PFSR50
RW	RW	–	–	RW	RW	RW	RW

Initial value : 00H

PFSR5[7:6]	P72 Function Select	
	PFSR57	PFSR56
	0	0
	0	1
	1	0
	1	1
		Description
		Port
		SEG26 Function
		REM Function
		Not used
PFSR53	P67 Function select	
	0	Port
	1	SEG23 Function
PFSR52	P66 Function Select	
	0	Port
	1	SEG22 Function
PFSR51	P65 Function select	
	0	Port
	1	SEG21 Function
PFSR50	P64 Function Select	
	0	Port
	1	SEG20 Function

PFSR6 (Port Function Selection Register 6) : F4H

7	6	5	4	3	2	1	0
–	–	–	–	PFSR63	PFSR62	PFSR61	PFSR60
–	–	–	–	RW	RW	RW	RW

Initial value : 00H

PFSR6[3:2] P74 Function Select

PFSR63	PFSR62	Description
0	0	Port
0	1	SEG28 Function
1	0	EC0 Function
1	1	Not used

PFSR6[1:0] P73 Function Select

PFSR61	PFSR60	Description
0	0	Port
0	1	SEG27 Function
1	0	T00/PWM00 Function
1	1	Not used

PFSR8 (Port Function Selection Register 8) : F6H

7	6	5	4	3	2	1	0
PFSR87	PFSR86	PFSR85	PFSR84	PFSR83	PFSR82	–	–
RW	RW	RW	RW	RW	RW	–	–

Initial value : 00H

PFSR8[7:6] P87 Function Select

PFSR87	PFSR86	Description
0	0	Port
0	1	SEG39 Function
1	0	RXD Function
1	1	Not used

PFSR8[5:4] P86 Function Select

PFSR85	PFSR84	Description
0	0	Port
0	1	SEG38 Function
1	0	TXD Function
1	1	Not used

PFSR8[3:2] P85 Function Select

PFSR83	PFSR82	Description
0	0	Port (EINT10 function possible when input)
0	1	SEG37 Function
1	0	ACK-in Function
1	1	ACK-out Function

10 Interrupt Controller

10.1 Overview

The MC96F6632S supports up to 23 interrupt sources. The interrupts have separate enable register bits associated with them, allowing software control. They can also have four levels of priority assigned to them. The non-maskable interrupt source is always enabled with a higher priority than any other interrupt source, and is not controllable by software. The interrupt controller has following features:

- Receive the request from 23 interrupt source
- 6 group priority
- 4 priority levels
- Multi Interrupt possibility
- If the requests of different priority levels are received simultaneously, the request of higher priority level is served first.
- Each interrupt source can be controlled by EA bit and each IEx bit
- Interrupt latency: 3~9 machine cycles in single interrupt system

The non-maskable interrupt is always enabled. The maskable interrupts are enabled through four pair of interrupt enable registers (IE, IE1, IE2, IE3). Each bit of IE, IE1, IE2, IE3 register individually enables/disables the corresponding interrupt source. Overall control is provided by bit 7 of IE (EA). When EA is set to '0', all interrupts are disabled: when EA is set to '1', interrupts are individually enabled or disabled through the other bits of the interrupt enable registers. The EA bit is always cleared to '0' jumping to an interrupt service vector and set to '1' executing the [RETI] instruction. The MC96F6632S supports a four-level priority scheme. Each maskable interrupt is individually assigned to one of four priority levels according to IP and IP1.

Default interrupt mode is level-trigger mode basically, but if needed, it is possible to change to edge-trigger mode. Table 10-1 shows the Interrupt Group Priority Level that is available for sharing interrupt priority. Priority of a group is set by two bits of interrupt priority registers (one bit from IP, another one from IP1). Interrupt service routine serves higher priority interrupt first. If two requests of different priority levels are received simultaneously, the request of higher priority level is served prior to the lower one.

Interrupt Group	Highest Lowest				
	→				
0 (Bit0)	Interrupt 0	Interrupt 6	Interrupt 12	Interrupt 18	Highest Lowest
1 (Bit1)	Interrupt 1	Interrupt 7	Interrupt 13	Interrupt 19	
2 (Bit2)	Interrupt 2	Interrupt 8	Interrupt 14	Interrupt 20	
3 (Bit3)	Interrupt 3	Interrupt 9	Interrupt 15	Interrupt 21	
4 (Bit4)	Interrupt 4	Interrupt 10	Interrupt 16	Interrupt 22	
5 (Bit5)	Interrupt 5	Interrupt 11	Interrupt 17	Interrupt 23	

Table 10-1. Interrupt Group Priority Level

10.2 External Interrupt

The external interrupt on INT1, INT2 and INT5 pins receive various interrupt request depending on the external interrupt edge register 0 (EIEDGE0), external interrupt edge register 1 (EIEDGE1), external interrupt polarity register 0 (EIPOL0) and external interrupt polarity register 1 (EIPOL1) as shown in Figure 10.1. Also each external interrupt source has enable/disable bits. The External interrupt flag register 0 (EIFLAG0) and external interrupt flag register 1 (EIFLAG1) provides the status of external interrupts.

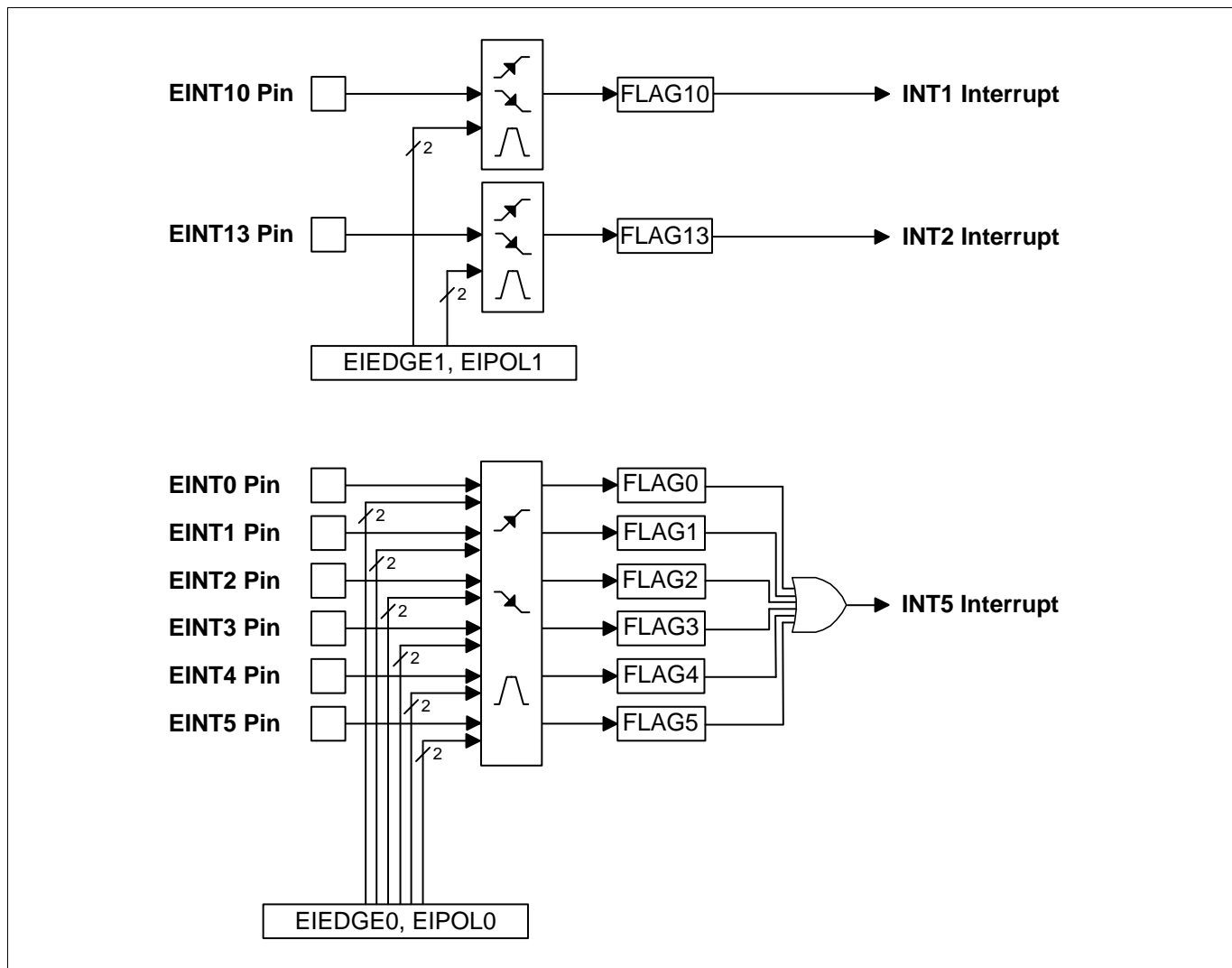

Figure 10-1. External Interrupt Description

10.3 Block Diagram

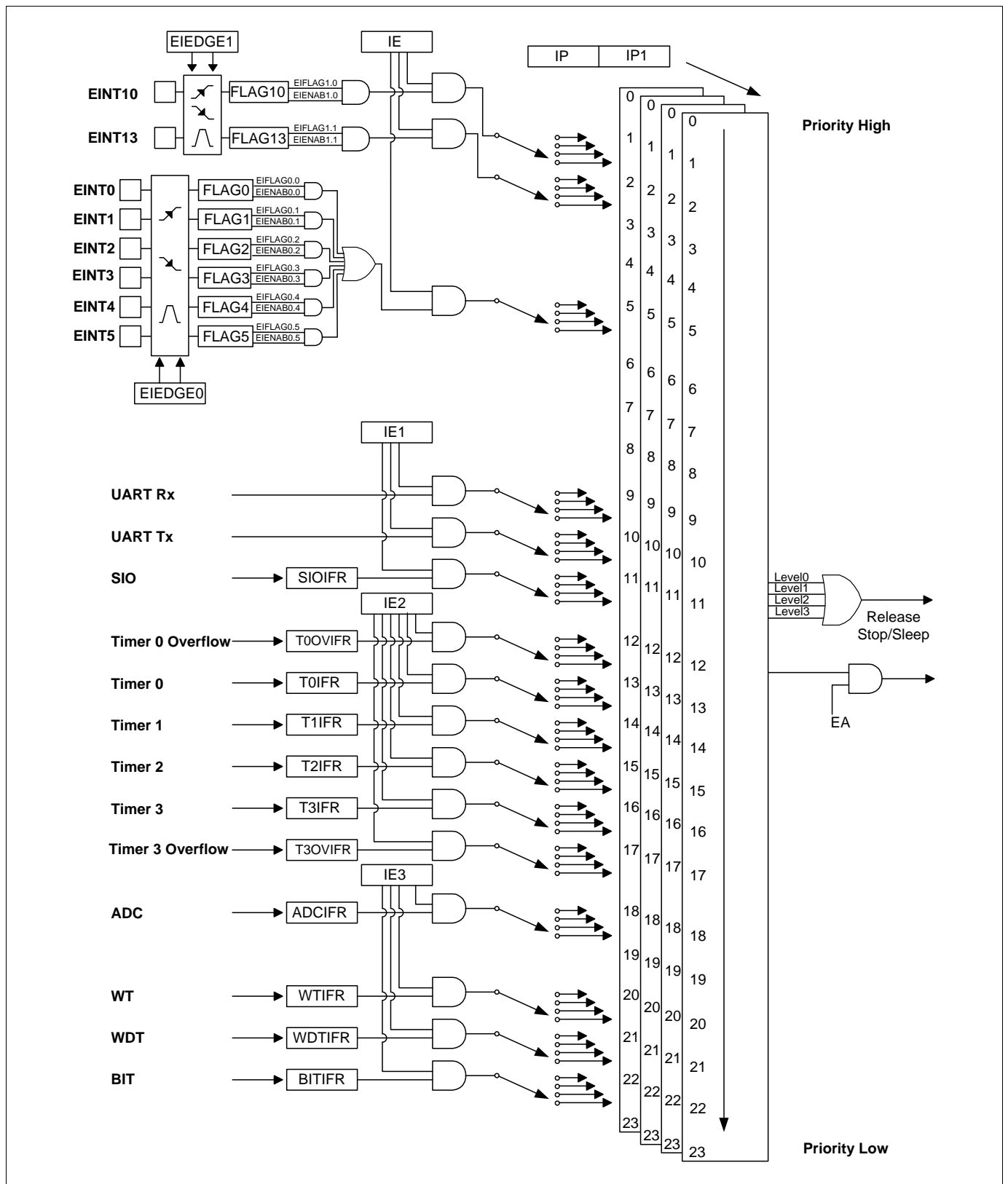

Figure 10-2. Block Diagram of Interrupt

NOTE)

1. The release signal for stop/idle mode may be generated by all interrupt sources which are enabled without reference to the priority level.
2. An interrupt request is delayed while data are written to IE, IE1, IE2, IE3, IP, IP1, and PCON register.

10.4 Interrupt Vector Table

The interrupt controller supports 24 interrupt sources as shown in the Table 10-2. When interrupt is served, long call instruction (LCALL) is executed and program counter jumps to the vector address. All interrupt requests have their own priority order.

Interrupt Source	Symbol	Interrupt Enable Bit	Priority	Mask	Vector Address
Hardware Reset	RESETB	-	0	Non-Maskable	0000H
-	INT0	IE.0	1	Maskable	0003H
External Interrupt 10	INT1	IE.1	2	Maskable	000BH
External Interrupt 13	INT2	IE.2	3	Maskable	0013H
-	INT3	IE.3	4	Maskable	001BH
-	INT4	IE.4	5	Maskable	0023H
External Interrupt 0 - 5	INT5	IE.5	6	Maskable	002BH
-	INT6	IE1.0	7	Maskable	0033H
-	INT7	IE1.1	8	Maskable	003BH
-	INT8	IE1.2	9	Maskable	0043H
UART Rx Interrupt	INT9	IE1.3	10	Maskable	004BH
UART Tx Interrupt	INT10	IE1.4	11	Maskable	0053H
SIO Interrupt	INT11	IE1.5	12	Maskable	005BH
T0 Overflow Interrupt	INT12	IE2.0	13	Maskable	0063H
T0 Match Interrupt	INT13	IE2.1	14	Maskable	006BH
T1 Match Interrupt	INT14	IE2.2	15	Maskable	0073H
T2 Match Interrupt	INT15	IE2.3	16	Maskable	007BH
T3 Match Interrupt	INT16	IE2.4	17	Maskable	0083H
T3 Overflow Interrupt	INT17	IE2.5	18	Maskable	008BH
ADC Interrupt	INT18	IE3.0	19	Maskable	0093H
-	INT19	IE3.1	20	Maskable	009BH
WT Interrupt	INT20	IE3.2	21	Maskable	00A3H
WDT Interrupt	INT21	IE3.3	22	Maskable	00ABH
BIT Interrupt	INT22	IE3.4	23	Maskable	00B3H
-	INT23	IE3.5	24	Maskable	00BBH

Table 10-2. Interrupt Vector Address Table

For maskable interrupt execution, EA bit must set '1' and specific interrupt must be enabled by writing '1' to associated bit in the IEx. If an interrupt request is received, the specific interrupt request flag is set to '1'. And it remains '1' until CPU accepts interrupt. If the interrupt is served, the interrupt request flag will be cleared automatically.

10.5 Interrupt Sequence

An interrupt request is held until the interrupt is accepted or the interrupt latch is cleared to '0' by a reset or an instruction. Interrupt acceptance always generates at last cycle of the instruction. So instead of fetching the current instruction, CPU executes internally LCALL instruction and saves the PC at stack. For the interrupt service routine, the interrupt controller gives the address of LJMP instruction to CPU. Since the end of the execution of current instruction, it needs 3~9 machine cycles to go to the interrupt service routine. The interrupt service task is terminated by the interrupt return instruction [RETI]. Once an interrupt request is generated, the following process is performed.

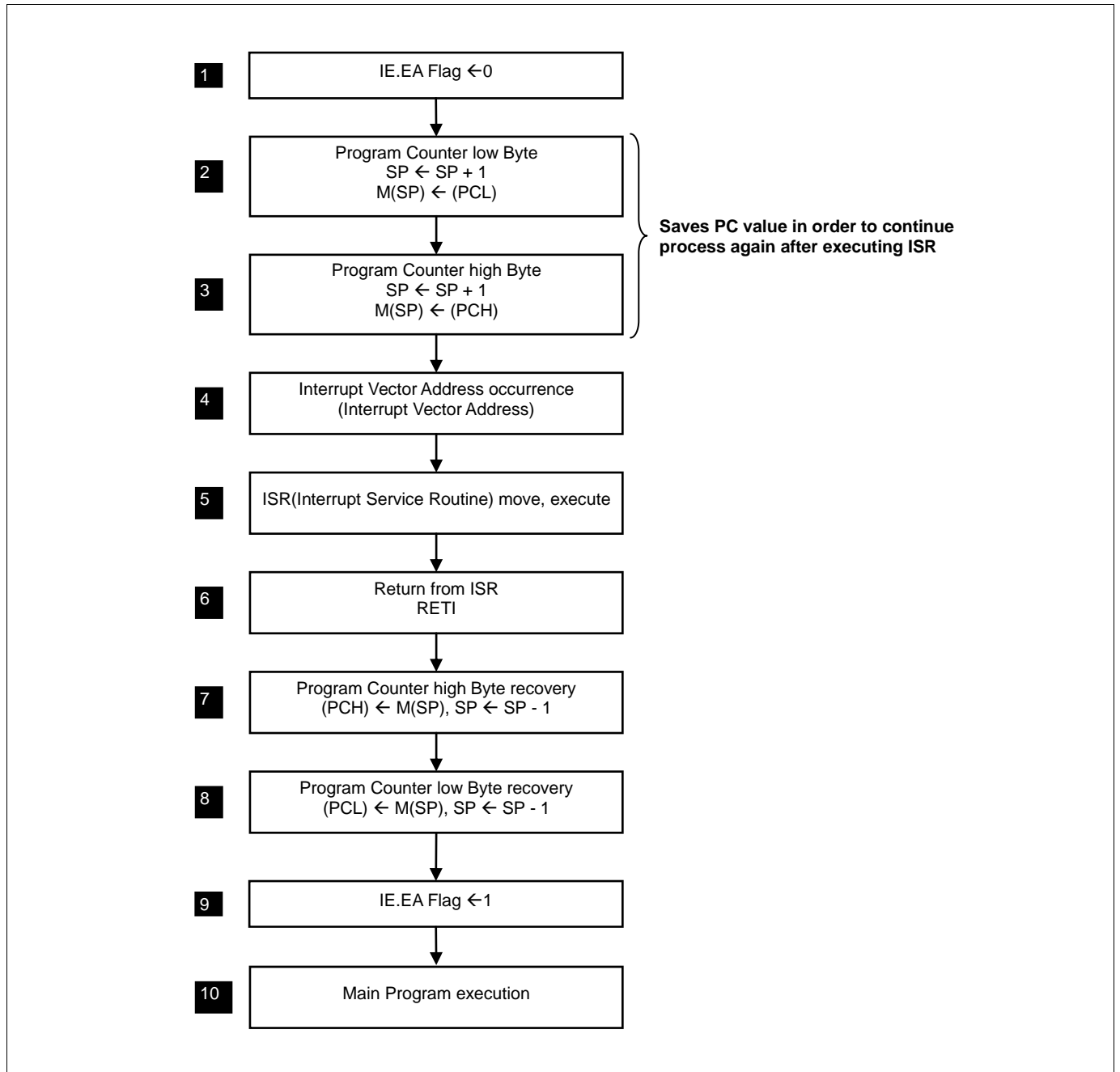

Figure 10-3. Interrupt Vector Address Table

10.6 Effective Timing after Controlling Interrupt Bit

Case a) Control Interrupt Enable Register (IE, IE1, IE2, IE3)

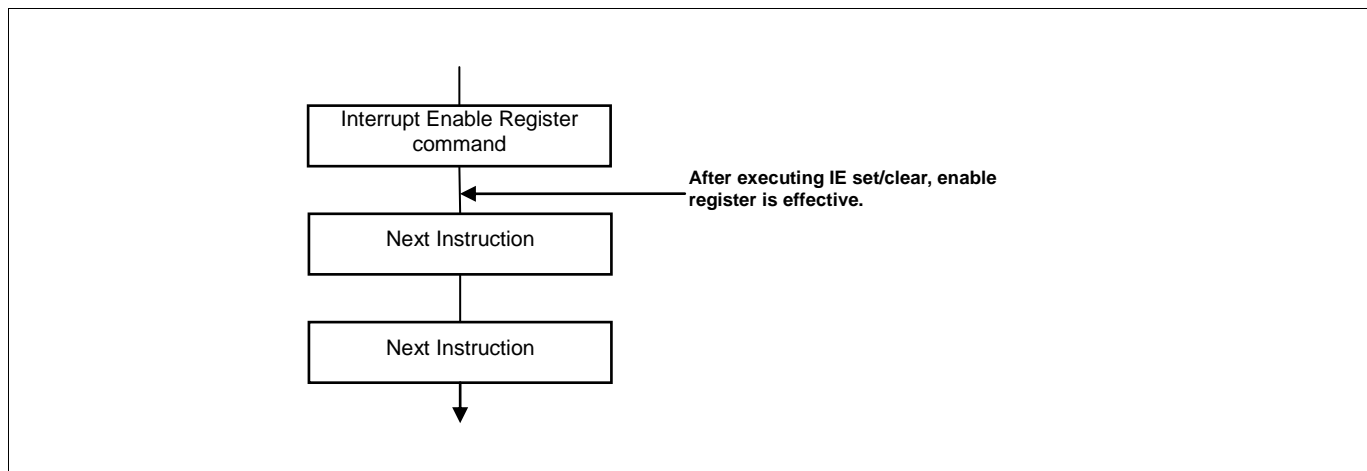

Figure 10-4. Effective Timing of Interrupt Enable Register

Case b) Interrupt flag Register

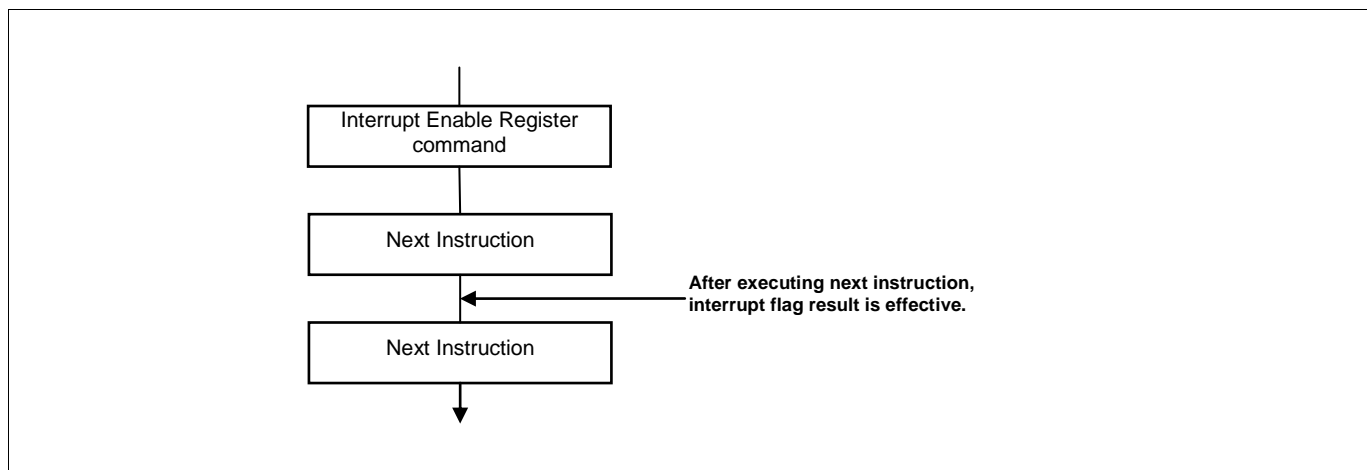

Figure 10-5. Effective Timing of Interrupt Flag Register

10.7 Multi Interrupt

If two requests of different priority levels are received simultaneously, the request of higher priority level is served first. If more than one interrupt request are received, the interrupt polling sequence determines which request is served first by hardware. However, for special features, multi-interrupt processing can be executed by software.

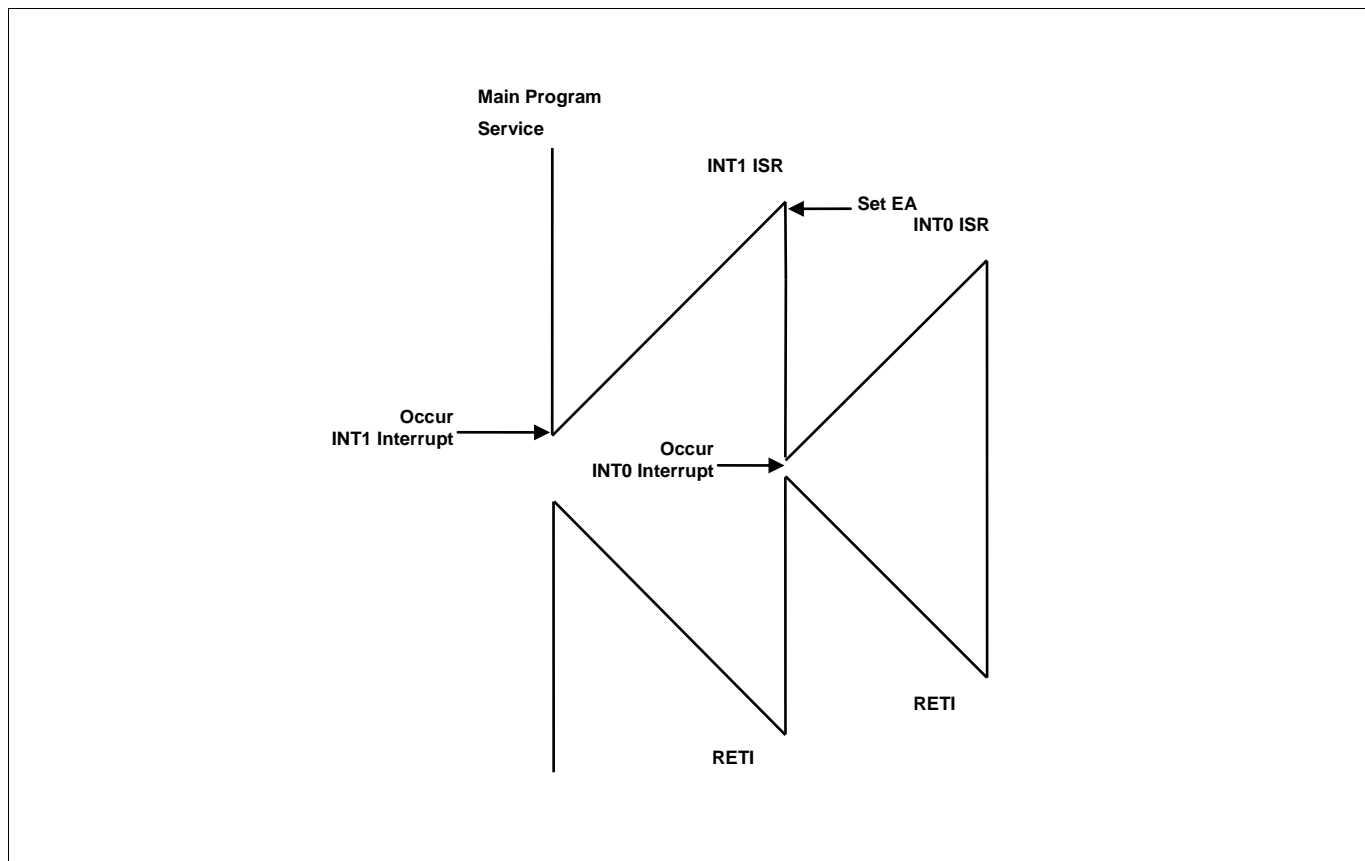

Figure 10-6. Effective Timing of Interrupt

Figure 10.6 shows an example of multi-interrupt processing. While INT1 is served, INT0 which has higher priority than INT1 is occurred. Then INT0 is served immediately and then the remain part of INT1 service routine is executed. If the priority level of INT0 is same or lower than INT1, INT0 will be served after the INT1 service has completed.

An interrupt service routine may be only interrupted by an interrupt of higher priority and, if two interrupts of different priority occur at the same time, the higher level interrupt will be served first. An interrupt cannot be interrupted by another interrupt of the same or a lower priority level. If two interrupts of the same priority level occur simultaneously, the service order for those interrupts is determined by the scan order.

10.8 Interrupt Enable Accept Timing

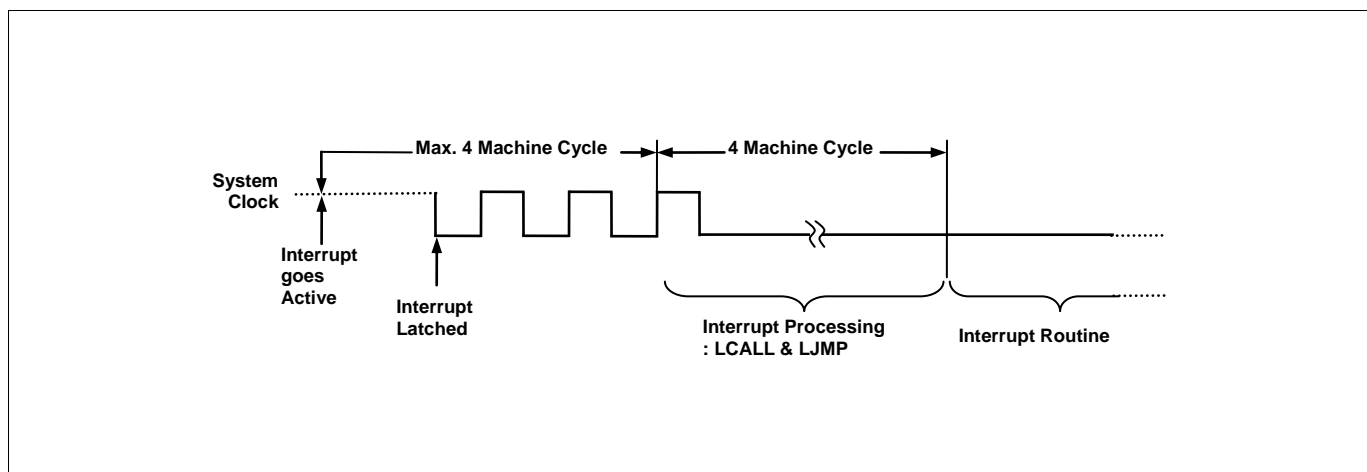

Figure 10-7. Interrupt Response Timing Diagram

10.9 Interrupt Service Routine Address

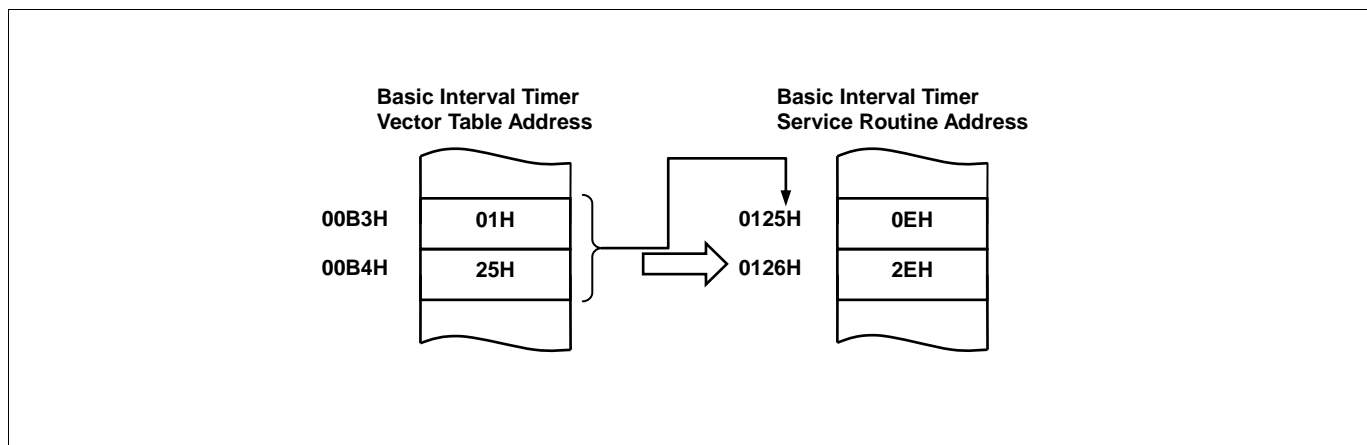

Figure 10-8. Correspondence between Vector Table Address and the Entry Address of ISP

10.10 Saving/Restore General-Purpose Registers

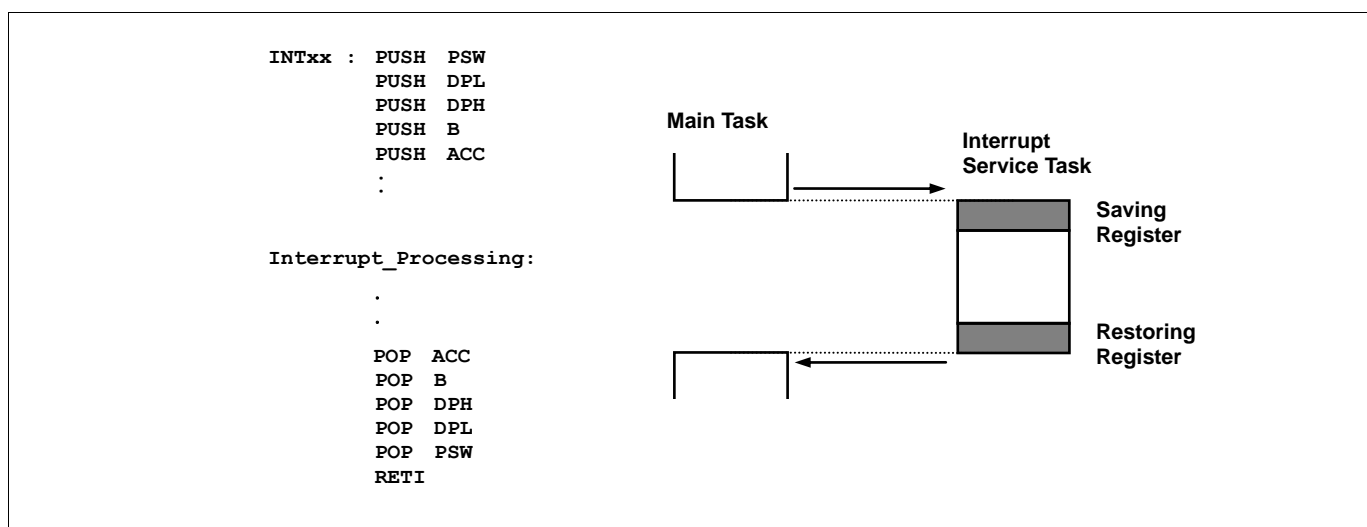

Figure 10-9. Saving/Restore Process Diagram and Sample Source

10.11 Interrupt Timing

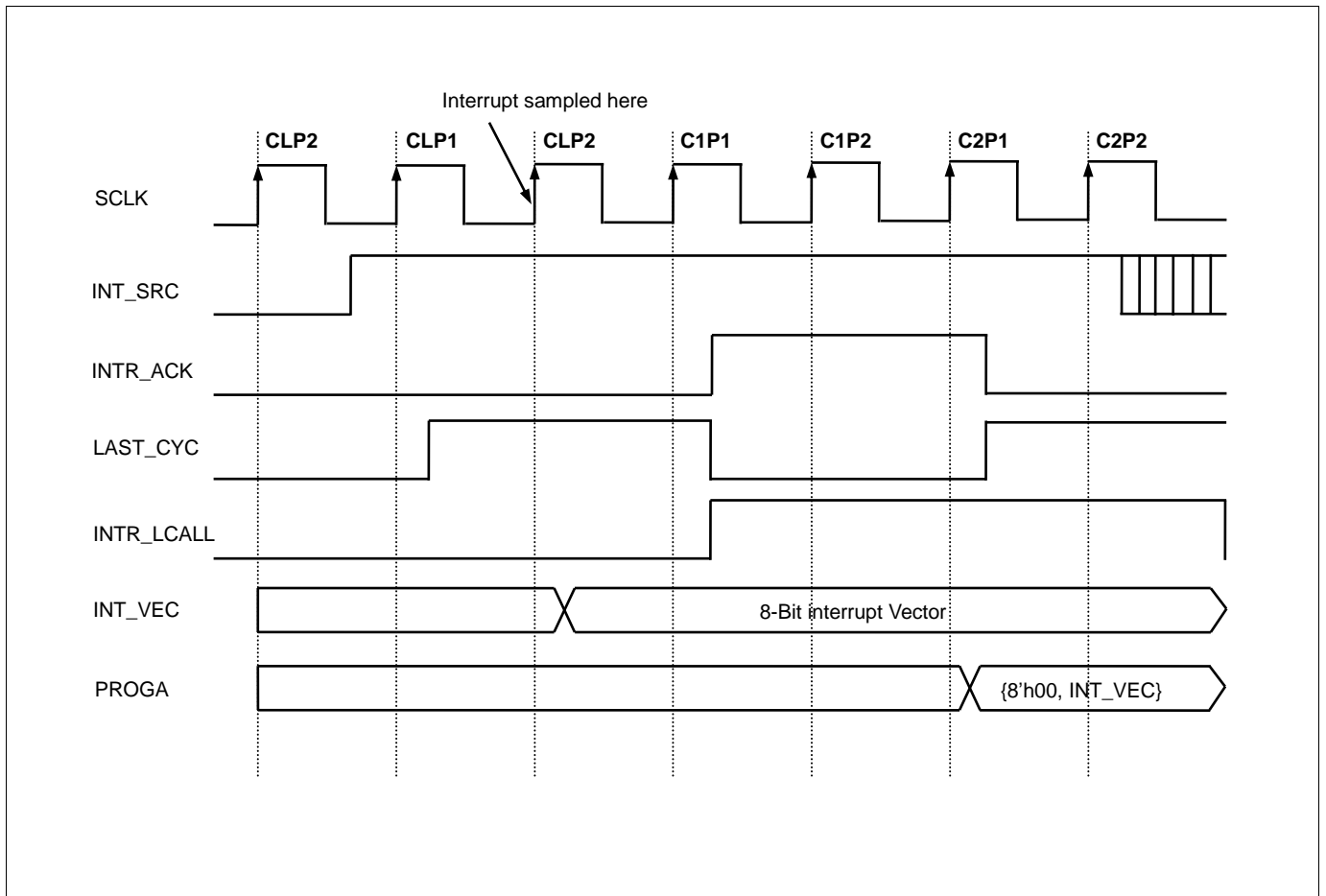

Figure 10-10. Timing Chart of Interrupt Acceptance and Interrupt Return Instruction

Interrupt sources are sampled at the last cycle of a command. If an interrupt source is detected the lower 8-bit of interrupt vector (INT_VEC) is decided. M8051W core makes interrupt acknowledge at the first cycle of a command, and executes long call to jump to interrupt service routine.

NOTE)

1. command cycle CLPx: L=Last cycle, 1=1st cycle or 1st phase, 2=2nd cycle or 2nd phase

10.12 Interrupt Register Overview

10.12.1 Interrupt Enable Register (IE, IE1, IE2, IE3)

Interrupt enable register consists of global interrupt control bit (EA) and peripheral interrupt control bits. Total 24 peripherals are able to control interrupt.

10.12.2 Interrupt Priority Register (IP, IP1)

The 24 interrupts are divided into 6 groups which have each 4 interrupt sources. A group can be assigned 4 levels interrupt priority using interrupt priority register. Level 3 is the highest priority, while level 0 is the lowest priority. After a reset IP and IP1 are cleared to '00H'. If interrupts have the same priority level, lower number interrupt is served first.

10.12.3 External Interrupt Flag Register (EIFLAG0, EIFLAG1)

The external interrupt flag register 0 (EIFLAG0) and external interrupt flag register 1 (EIFLAG1) are set to '1' when the external interrupt generating condition is satisfied. The flag is cleared when the interrupt service routine is executed. Alternatively, the flag can be cleared by writing '0' to it.

10.12.4 External Interrupt Edge Register (EIEDGE0, EIEDGE1)

The external interrupt edge register 0 (EIEDGE0) and external interrupt edge register 1 (EIEDGE1) determine which type of interrupt will be used, edge sensitive or level sensitive. Initially, default value sets level sensitive interrupt. For level sensitive interrupt, write '0' to the related bit. For edge sensitive interrupt, write '1' to the related bit.

10.12.5 External Interrupt Polarity Register (EIPOL0, EIPOL1)

According to EIEDGE0 and EIEDGE1 registers, the external interrupt polarity register 0 (EIPOL0) and external interrupt polarity register 1 (EIPOL1) have different meaning. If level sensitive interrupt is selected, EIPOL0 and EIPOL1 determine the level of interrupt (high or low level). If edge sensitive interrupt is selected, EIPOL0 and EIPOL1 determine the edge of interrupt (rising or falling edge).

10.12.6 External Interrupt Enable Register (EIENAB0, EIENAB1)

When the external interrupt enable register 0 (EIENAB0) and external interrupt enable register 1 (EIENAB1) register are written to '1', the corresponding external pin interrupt is enabled.

10.12.7 Register Map

Name	Address	Dir	Default	Description
IE	A8H	R/W	00H	Interrupt Enable Register
IE1	A9H	R/W	00H	Interrupt Enable Register 1
IE2	AAH	R/W	00H	Interrupt Enable Register 2
IE3	ABH	R/W	00H	Interrupt Enable Register 3
IP	B8H	R/W	00H	Interrupt Priority Register
IP1	F8H	R/W	00H	Interrupt Priority Register 1
EIFLAG0	ADH	R/W	00H	External Interrupt Flag Register 0
EIEDGE0	AEH	R/W	00H	External Interrupt Edge Register 0
EIPOL0	AFH	R/W	00H	External Interrupt Polarity Register 0
EIENAB0	ACH	R/W	00H	External Interrupt Enable Register 0
EIFLAG1	A4H	R/W	00H	External Interrupt Flag Register 1
EIEDGE1	A5H	R/W	00H	External Interrupt Edge Register 1
EIPOL1	A6H	R/W	00H	External Interrupt Polarity Register 1
EIENAB1	A3H	R/W	00H	External Interrupt Enable Register 1

Table 10-3. Interrupt Register Map

10.12.8 Interrupt Register Description

The interrupt register is used for controlling interrupt functions. Also it has external interrupt control registers. The interrupt register consists of interrupt enable register (IE), interrupt enable register 1 (IE1), interrupt enable register 2 (IE2) and interrupt enable register 3 (IE3). For external interrupt, it consists of external interrupt flag register 0 (EIFLAG0), external interrupt edge register 0 (EIEDGE0), external interrupt polarity register 0 (EIPOL0), external interrupt enable register 0 (EIENAB0), external interrupt flag register 1 (EIFLAG1), external interrupt edge register 1 (EIEDGE1), external interrupt polarity register 1 (EIPOL1) and external interrupt enable register 1 (EIENAB1).

10.12.9 Register Description for Interrupt

IE (Interrupt Enable Register) : A8H

7	6	5	4	3	2	1	0
EA	–	INT5E	–	–	INT2E	INT1E	–
RW	–	RW	–	–	RW	RW	–

Initial value : 00H

- EA** Enable or Disable All Interrupt bits
 - 0 All Interrupt disable
 - 1 All Interrupt enable
- INT5E** Enable or Disable External Interrupt 0 ~ 5 (EINT0 ~ EINT5)
 - 0 Disable
 - 1 Enable
- INT2E** Enable or Disable External Interrupt 13 (EINT13)
 - 0 Disable
 - 1 Enable
- INT1E** Enable or Disable External Interrupt 10 (EINT10)
 - 0 Disable
 - 1 Enable

IE1 (Interrupt Enable Register 1): A9H

7	6	5	4	3	2	1	0
–	–	INT11E	INT10E	INT9E	–	–	–
–	–	RW	RW	RW	–	–	–

Initial value: 00H

- INT11E** Enable or Disable SIO Interrupt
 - 0 Disable
 - 1 Enable
- INT10E** Enable or Disable UART Tx Interrupt
 - 0 Disable
 - 1 Enable
- INT9E** Enable or Disable UART Rx Interrupt
 - 0 Disable
 - 1 Enable

IE2 (Interrupt Enable Register 2) : AAH

7	6	5	4	3	2	1	0
–	–	INT17E	INT16E	INT15E	INT14E	INT13E	INT12E
–	–	RW	RW	RW	RW	RW	RW

Initial value : 00H

INT17E	Enable or Disable Timer 3 Overflow Interrupt
0	Disable
1	Enable
INT16E	Enable or Disable Timer 3 Interrupt
0	Disable
1	Enable
INT15E	Enable or Disable Timer 2 Interrupt
0	Disable
1	Enable
INT14E	Enable or Disable Timer 1 Interrupt
0	Disable
1	Enable
INT13E	Enable or Disable Timer 0 Interrupt
0	Disable
1	Enable
INT12E	Enable or Disable Timer 0 Overflow Interrupt
0	Disable
1	Enable

IE3 (Interrupt Enable Register 3) : ABH

7	6	5	4	3	2	1	0
–	–	–	INT22E	INT21E	INT20E	–	INT18E
–	–	–	RW	RW	RW	–	RW

Initial value : 00H

INT22E	Enable or Disable BIT Interrupt
0	Disable
1	Enable
INT21E	Enable or Disable WDT Interrupt
0	Disable
1	Enable
INT20E	Enable or Disable WT Interrupt
0	Disable
1	Enable
INT18E	Enable or Disable ADC Interrupt
0	Disable
1	Enable

IP (Interrupt Priority Register) : B8H

7	6	5	4	3	2	1	0
–	–	IP5	IP4	IP3	IP2	IP1	IP0
–	–	RW	RW	RW	RW	RW	RW

Initial value : 00H

IP1 (Interrupt Priority Register 1) : F8H

7	6	5	4	3	2	1	0
–	–	IP15	IP14	IP13	IP12	IP11	IP10
–	–	RW	RW	RW	RW	RW	RW

Initial value : 00H

IP[5:0], IP1[5:0]	Select Interrupt Group Priority		
	IP1x	IPx	Description
	0	0	level 0 (lowest)
	0	1	level 1
	1	0	level 2
	1	1	level 3 (highest)

EIFLAG0 (External Interrupt Flag Register 0) : ADH

7	6	5	4	3	2	1	0
–	–	FLAG5	FLAG4	FLAG3	FLAG2	FLAG1	FLAG0
–	–	RW	RW	RW	RW	RW	RW

Initial value : 00H

EIFLAG0[5:0] When an External Interrupt is occurred, the flag becomes '1'. The flag is cleared only by writing '0' to the bit. So, the flag should be cleared by software. Writing "1" has no effect

0	External Interrupt 0 ~ 5 not occurred
1	External Interrupt 0 ~ 5 occurred

EIEDGE0 (External Interrupt Edge Register 0): AEH

7	6	5	4	3	2	1	0
–	–	EDGE5	EDGE4	EDGE3	EDGE2	EDGE1	EDGE0
–	–	RW	RW	RW	RW	RW	RW

Initial value : 00H

EIEDGE0[5:0] Determines which type of interrupt will be used; edge sensitive or level sensitive.

0	Level (default)
1	Edge

EIPOL0 (External Interrupt Polarity Register 0): AFH

7	6	5	4	3	2	1	0
–	–	POL5	POL4	POL3	POL2	POL1	POL0
–	–	RW	RW	RW	RW	RW	RW

Initial value: 00H

EIPOL0[5:0] According to EIEDGE0, external interrupt polarity register has different meaning. If EIEDGE0 is set to select level sensitive interrupt, EIPOL0 determines high or low level interrupt. If EIEDGE0 is set to select edge sensitive interrupt, EIPOL0 determines rising or falling edge interrupt.

Level case:

0 When High level, Interrupt occurred (Default)

1 When Low level, Interrupt occurred

Edge case:

0 When Rising edge, Interrupt occurred (Default)

1 When Falling edge, Interrupt occurred

EIENAB0 (External Interrupt Enable Register 0) : ACH

7	6	5	4	3	2	1	0
–	–	ENAB5	ENAB4	ENAB3	ENAB2	ENAB1	ENAB0
–	–	RW	RW	RW	RW	RW	RW

Initial value : 00H

EIENAB0[5:0] Control External Interrupt 0~5 (P0[5:0])

0 Disable (Default)

1 Enable

EIFLAG1 (External Interrupt Flag Register 1) : A4H

7	6	5	4	3	2	1	0
–	–	–	–	–	–	FLAG13	FLAG10
–	–	–	–	–	–	RW	RW

Initial value : 00H

EIFLAG1[1:0] When an External Interrupt is occurred, the flag becomes '1'. The flag is cleared only by writing '0' to the bit or automatically cleared by INT_ACK signal. Writing "1" has no effect

0 External Interrupt 10 and 13 not occurred

1 External Interrupt 10 and 13 occurred

EIEDGE1 (External Interrupt Edge Register 1) : A5H

7	6	5	4	3	2	1	0
–	–	–	–	–	–	EDGE13	EDGE10
–	–	–	–	–	–	RW	RW

Initial value : 00H

EIEDGE1[1:0] Determines which type of interrupt will be used; edge sensitive or level sensitive.

0 Level (default)

1 Edge

EIPOL1 (External Interrupt Polarity Register 1) : A6H

7	6	5	4	3	2	1	0
–	–	–	–	–	–	POL13	POL10
–	–	–	–	–	–	R/W	R/W

Initial value : 00H

EIPOL1[1:0] According to EIEDGE1, external interrupt polarity register has different meaning. If EIEDGE1 is set to select level sensitive interrupt, EIPOL1 determines high or low level interrupt. If EIEDGE1 is set to select edge sensitive interrupt, EIPOL1 determines rising or falling edge interrupt.

Level case:

- 0 When High level, Interrupt occurred (Default)
- 1 When Low level, Interrupt occurred

Edge case:

- 0 When Rising edge, Interrupt occurred (Default)
- 1 When Falling edge, Interrupt occurred

EIENAB1 (External Interrupt Enable Register 1) : A3H

7	6	5	4	3	2	1	0
–	–	–	–	–	–	ENAB13	ENAB10
–	–	–	–	–	–	R/W	R/W

Initial value : 00H

EIENAB1[1:0] Control External Interrupt 10 and 13 (P85, P12)

- 0 Disable (Default)
- 1 Enable

11 Peripheral Hardware

11.1 Clock Generator

11.1.1 Overview

As shown in Figure 11.1, the clock generator produces the basic clock pulses which provide the system clock to be supplied to the CPU and the peripheral hardware. It contains main/sub-frequency clock oscillator. The main/sub clock operation can be easily obtained by attaching a crystal between the XIN/SXIN and XOUT/SXOUT pin, respectively. The main/sub clock can be also obtained from the external oscillator. In this case, it is necessary to put the external clock signal into the XIN/SXIN pin and open the XOUT/SXOUT pin. The default system clock is 1MHz INT-RC Oscillator and the default division rate is eight. In order to stabilize system internally, it is used 1MHz INT-RC oscillator on POR.

- Calibrated Internal RC Oscillator (8MHz)
 - INT-RC OSC/1 (8MHz)
 - INT-RC OSC/2 (4MHz)
 - INT-RC OSC/4 (2MHz)
 - INT-RC OSC/8 (1MHz, Default system clock)
- Main Crystal Oscillator (1~12MHz)
- Sub Crystal Oscillator (32.768kHz)
- Internal WDTRC Oscillator (5kHz)

11.1.2 Block Diagram

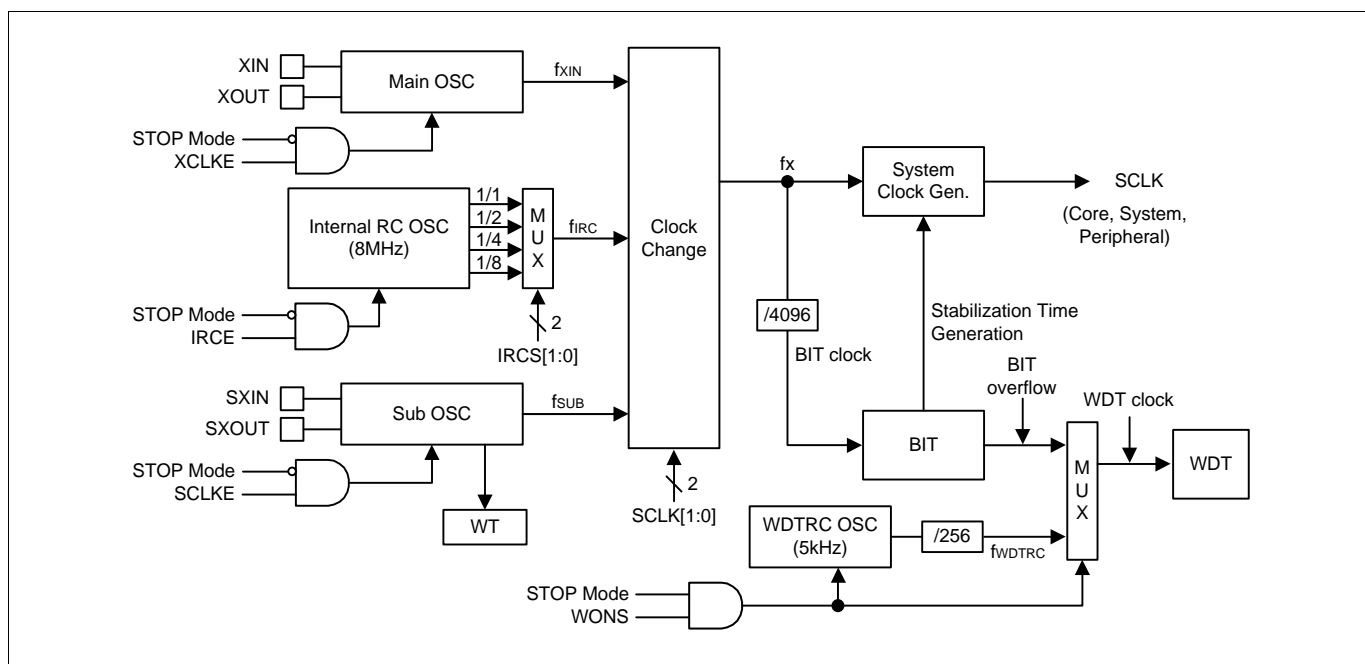

Figure 11-1. Clock Generator Block Diagram

11.1.3 Register Map

Name	Address	Dir	Default	Description
SCCR	8AH	R/W	00H	System and Clock Control Register
OSCCR	D9H	R/W	00H	Oscillator Control Register

Table 11-1. Clock Generator Register Map

11.1.4 Clock Generator Register Description

The clock generator register uses clock control for system operation. The clock generation consists of System and clock control register and oscillator control register.

11.1.5 Register Description for Clock Generator

SCCR (System and Clock Control Register) : 8AH

7	6	5	4	3	2	1	0
WONS	PSAVE	–	–	–	–	SCLK1	SCLK0
RW	RW	–	–	–	–	RW	RW

Initial value : 00H

WONS Control the Operation of WDT RC-Oscillation during STOP mode
 0 WDTRC-Oscillator is disabled at STOP mode
 1 WDTRC-Oscillator is enabled at STOP mode

NOTE)

- When this bit is “1”, the WDTRC oscillator (5kHz) is oscillated and selected as the clock source of the WDT block in the STOP mode, but the WDTRC stops and the BIT overflow clock is the clock source for the WDT block at normal mode.
- When this bit is “0”, the WDTRC is always stopped and the BIT overflow clock is selected as the clock source for the WDT block

PSAVE Power Save Mode Control Bit
 0 Normal circuit for sub oscillator
 1 Power saving circuit for sub oscillator

NOTE)

- A capacitor (0.1μF) should be connected between VREG and VSS when the sub oscillator is used to power saving mode.
- The PSAVE automatically cleared to ‘0’ when the sub oscillator is stopped by SCLKE or CPU is entered into STOP mode in sub operating mode.
- The delay is needed 500ms over from sub OSC start to PSAVE change to “1”.

SCLK [1:0] System Clock Selection Bit

SCLK1	SCLK0	Description
0	0	INT RC OSC for system clock
0	1	External Main OSC (f _{XIN}) for system clock
1	x	External Sub OSC (f _{SUB}) for system clock

Where x is “don’t care.”

OSCCR (Oscillator Control Register) : D9H

7	6	5	4	3	2	1	0
-	-	-	IRCS1	IRCS0	IRCE	XCLKE	SCLKE
-	-	-	RW	RW	RW	RW	RW

Initial value : 00H

IRCS[1:0] Internal RC Oscillator Post-divider Selection

IRCS1	IRCS0	Description
0	0	INT-RC/8 (1MHz)
0	1	INT-RC/4 (2MHz)
1	0	INT-RC/2 (4MHz)
1	1	INT-RC/1 (8MHz)

IRCE Control the Operation of the Internal RC Oscillator

0	Enable operation of INT-RC OSC
1	Disable operation of INT-RC OSC

XCLKE Control the Operation of the External Main Oscillator

0	Disable operation of main crystal oscillator
1	Enable operation of main crystal oscillator

SCLKE Control the Operation of the External Sub Oscillator

0	Disable operation of sub crystal oscillator
1	Enable operation of sub crystal oscillator

NOTE)

1. The delay is needed 500ms over from sub OSC start to PSAVE change to "1".

11.2 Basic Interval Timer

11.2.1 Overview

The MC96F6632S has one 8-bit basic interval timer that is free-run and can't stop. Block diagram is shown in Figure 11.2. In addition, the basic interval timer generates the time base for watchdog timer counting. It also provides a basic interval timer interrupt (BITIFR).

The MC96F6632S has these basic interval timer (BIT) features:

- During Power On, BIT gives a stable clock generation time
- On exiting Stop mode, BIT gives a stable clock generation time
- As timer function, timer interrupt occurrence

11.2.2 Block Diagram

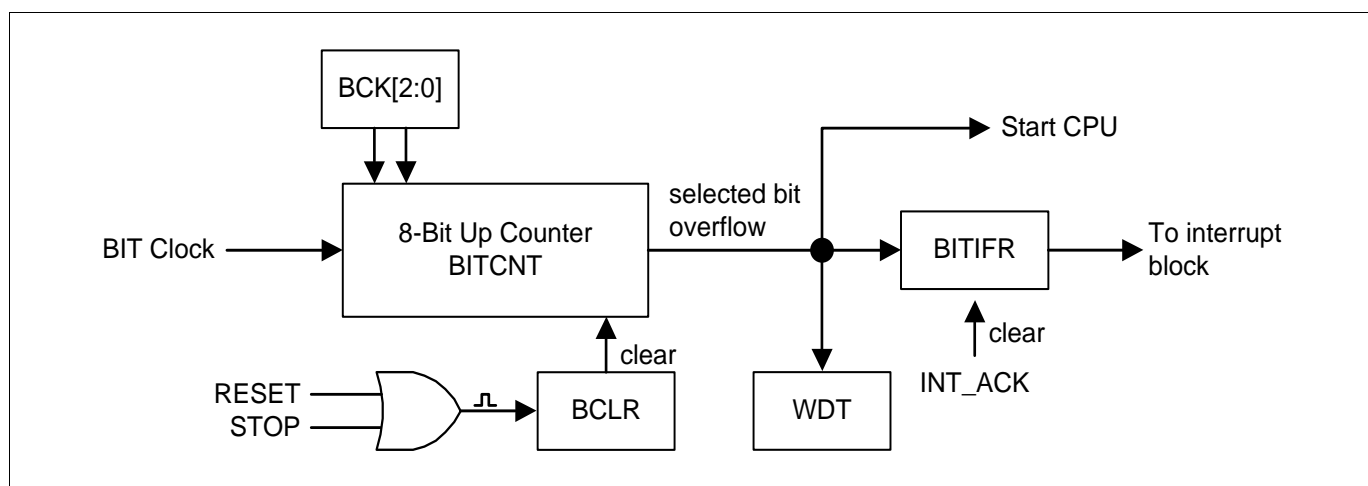

Figure 11-2. Basic Interval Timer Block Diagram

11.2.3 Register Map

Name	Address	Dir	Default	Description
BITCNT	8CH	R	00H	Basic Interval Timer Counter Register
BITCR	8BH	R/W	01H	Basic Interval Timer Control Register

Table 11-2. Basic Interval Timer Register Map

11.2.4 Basic Interval Timer Register Description

The basic interval timer register consists of basic interval timer counter register (BITCNT) and basic interval timer control register (BITCR). If BCLR bit is set to '1', BITCNT becomes '0' and then counts up. After 1 machine cycle, BCLR bit is cleared to '0' automatically.

11.2.5 Register Description for Basic Interval Timer

BITCNT (Basic Interval Timer Counter Register) : 8CH

7	6	5	4	3	2	1	0
BITCNT7	BITCNT6	BITCNT5	BITCNT4	BITCNT3	BITCNT2	BITCNT1	BITCNT0
R	R	R	R	R	R	R	R

Initial value : 00H

BITCNT[7:0] BIT Counter

BITCR (Basic Interval Timer Control Register) : 8BH

7	6	5	4	3	2	1	0
BITIFR	–	–	–	BCLR	BCK2	BCK1	BCK0
RW	–	–	–	RW	RW	RW	RW

Initial value : 01H

BITIFR When BIT Interrupt occurs, this bit becomes '1'. For clearing bit, write '0' to this bit or auto clear by INT_ACK signal. Writing "1" has no effect.

0 BIT interrupt no generation

1 BIT interrupt generation

BCLR If this bit is written to '1', BIT Counter is cleared to '0'

0 Free Running

1 Clear Counter

BCK[2:0] Select BIT overflow period

BCK2	BCK1	BCK0	Description
0	0	0	Bit 0 overflow (BIT Clock * 2)
0	0	1	Bit 1 overflow (BIT Clock * 4) (default)
0	1	0	Bit 2 overflow (BIT Clock * 8)
0	1	1	Bit 3 overflow (BIT Clock * 16)
1	0	0	Bit 4 overflow (BIT Clock * 32)
1	0	1	Bit 5 overflow (BIT Clock * 64)
1	1	0	Bit 6 overflow (BIT Clock * 128)
1	1	1	Bit 7 overflow (BIT Clock * 256)

11.3 Watch Dog Timer

11.3.1 Overview

The watchdog timer rapidly detects the CPU malfunction such as endless looping caused by noise or something like that, and resumes the CPU to the normal state. The watchdog timer signal for malfunction detection can be used as either a CPU reset or an interrupt request. When the watchdog timer is not being used for malfunction detection, it can be used as a timer to generate an interrupt at fixed intervals. It is possible to use free running 8-bit timer mode (WDTRSON='0') or watch dog timer mode (WDTRSON='1') as setting WDTCR[6] bit. If WDTCR[5] is written to '1', WDT counter value is cleared and counts up. After 1 machine cycle, this bit is cleared to '0' automatically. The watchdog timer consists of 8-bit binary counter and the watchdog timer data register. When the value of 8-bit binary counter is equal to the 8 bits of WDCNT, the interrupt request flag is generated. This can be used as Watchdog timer interrupt or reset of CPU in accordance with the bit WDTRSON.

The input clock source of watch dog timer is the BIT overflow. The interval of watchdog timer interrupt is decided by BIT overflow period and WDTDR set value. The equation can be described as

$$\text{WDT Interrupt Interval} = (\text{BIT Interrupt Interval}) \times (\text{WDTDR Value} + 1)$$

11.3.2 WDT Interrupt Timing Waveform

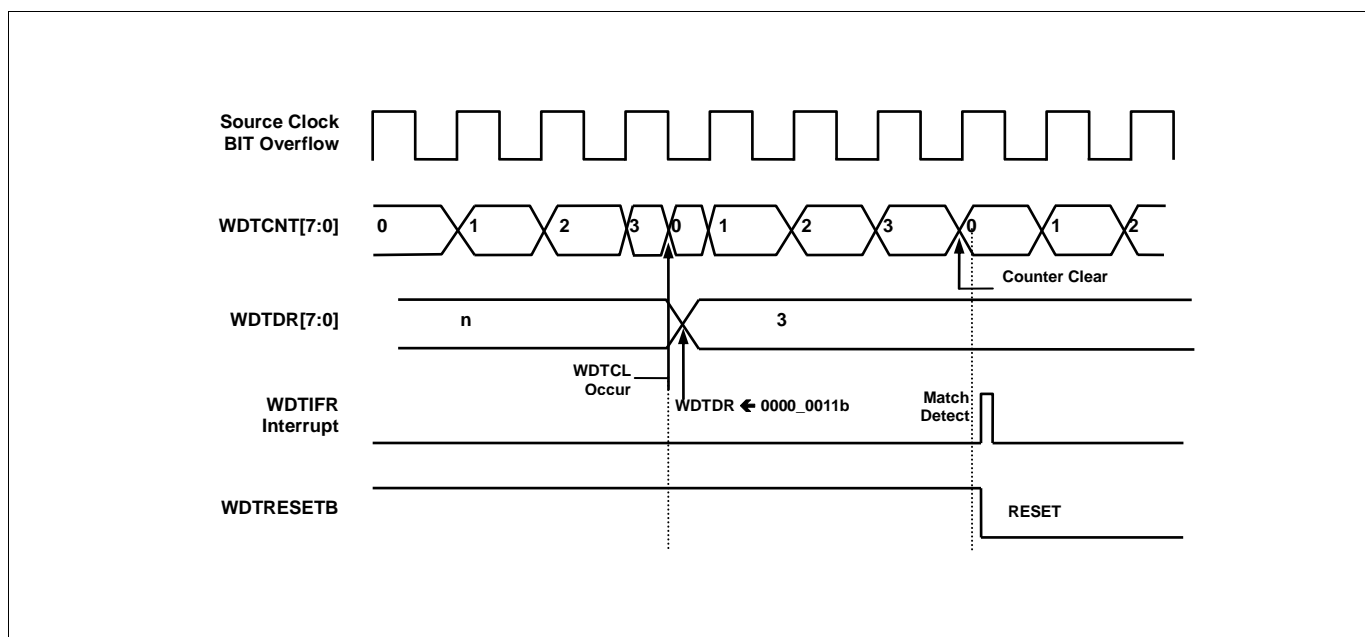

Figure 11-3. Watch Dog Timer Interrupt Timing Waveform

11.3.3 Block Diagram

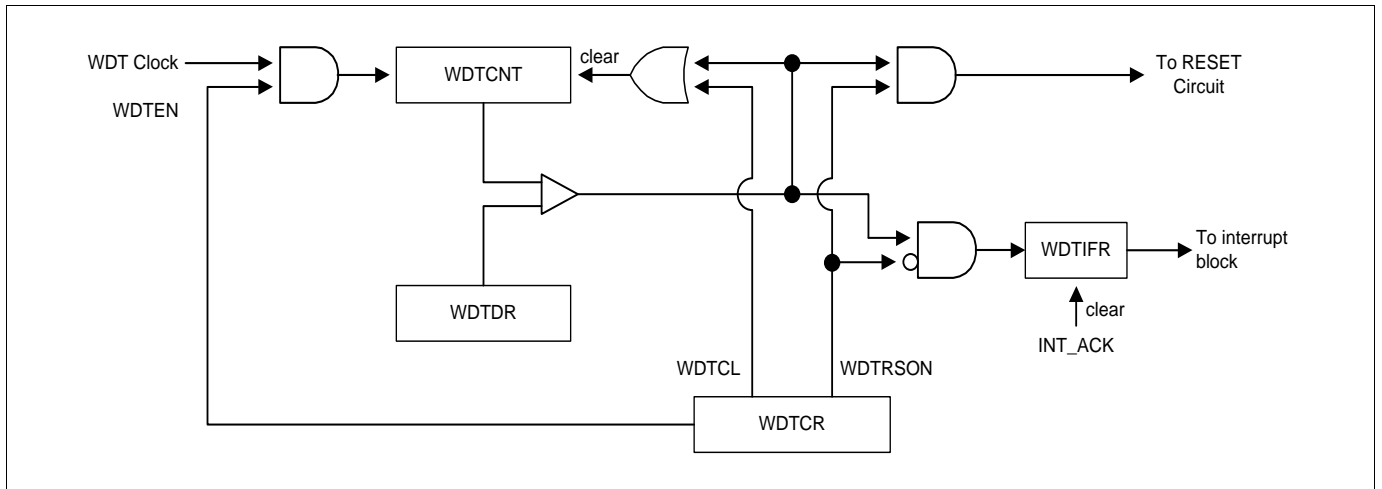

Figure 11-4. Watch Dog Timer Block Diagram

11.3.4 Register Map

Name	Address	Dir	Default	Description
WDCNT	8EH	R	00H	Watch Dog Timer Counter Register
WDTDR	8EH	W	FFH	Watch Dog Timer Data Register
WDTCR	8DH	R/W	00H	Watch Dog Timer Control Register

Table 11-3. Watch Dog Timer Register Map

11.3.5 Watch Dog Timer Register Description

The watch dog timer register consists of watch dog timer counter register (WDCNT), watch dog timer data register (WDTDR) and watch dog timer control register (WDTCR).

11.3.6 Register Description for Watch Dog Timer

WDTCNT (Watch Dog Timer Counter Register: Read Case) : 8EH

7	6	5	4	3	2	1	0
WDTCNT7	WDTCNT6	WDTCNT5	WDTCNT4	WDTCNT3	WDTCNT2	WDTCNT1	WDTCNT0
R	R	R	R	R	R	R	R

Initial value : 00H

WDTCNT[7:0] WDT Counter

WDTDR (Watch Dog Timer Data Register: Write Case) : 8EH

7	6	5	4	3	2	1	0
WDTDR7	WDTDR6	WDTDR5	WDTDR4	WDTDR3	WDTDR2	WDTDR1	WDTDR0
W	W	W	W	W	W	W	W

Initial value : FFH

WDTDR[7:0] Set a period
 WDT Interrupt Interval=(BIT Interrupt Interval) x(WDTDR Value+1)

NOTE)

1. Do not write "0" in the WDTDR register.

WDTCR (Watch Dog Timer Control Register) : 8DH

7	6	5	4	3	2	1	0
WDTEN	WDRSON	WDTCL	-	-	-	-	WDTIFR
RW	RW	RW	-	-	-	-	RW

Initial value : 00H

WDTEN Control WDT Operation

- 0 Disable
- 1 Enable

WDRSON Control WDT RESET Operation

- 0 Free Running 8-bit timer
- 1 Watch Dog Timer RESET ON

WDTCL Clear WDT Counter

- 0 Free Run
- 1 Clear WDT Counter (auto clear after 1 Cycle)

WDTIFR When WDT Interrupt occurs, this bit becomes '1'. For clearing bit, write '0' to this bit or auto clear by INT_ACK signal. Writing "1" has no effect.

- 0 WDT Interrupt no generation
- 1 WDT Interrupt generation

11.4 Watch Timer

11.4.1 Overview

The watch timer has the function for RTC (Real Time Clock) operation. It is generally used for RTC design. The internal structure of the watch timer consists of the clock source select circuit, timer counter circuit, output select circuit, and watch timer control register. To operate the watch timer, determine the input clock source, output interval, and set WTEN to '1' in watch timer control register (WTCR). It is able to execute simultaneously or individually. To stop or reset WT, clear the WTEN bit in WTCR register. Even if CPU is STOP mode, sub clock is able to be so alive that WT can continue the operation. The watch timer counter circuits may be composed of 21-bit counter which contains low 14-bit with binary counter and high 7-bit counter in order to raise resolution. In WTDR, it can control WT clear and set interval value at write time, and it can read 7-bit WT counter value at read time.

The watch timer supplies the clock frequency for the LCD driver (f_{LCD}). Therefore, if the watch timer is disabled, the LCD driver controller does not operate.

11.4.2 Block Diagram

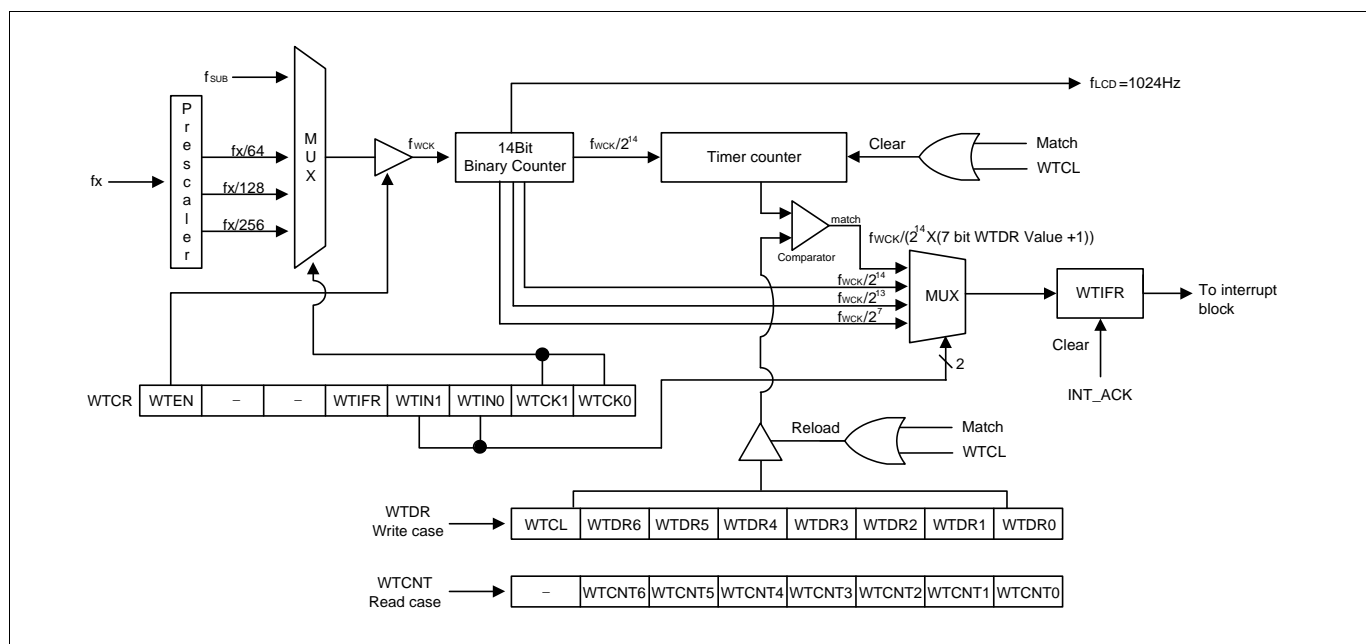

Figure 11-5. Watch Timer Block Diagram

11.4.3 Register Map

Name	Address	Dir	Default	Description
WTCNT	9FH	R	00H	Watch Timer Counter Register
WTDR	9FH	W	7FH	Watch Timer Data Register
WTCR	9EH	R/W	00H	Watch Timer Control Register

Table 11-4. Watch Timer Register Map

11.4.4 Watch Timer Register Description

The watch timer register consists of watch timer counter register (WTCNT), watch timer data register (WTDR), and watch timer control register (WTCR). As WTCR is 6-bit writable/ readable register, WTCR can control the clock source (WTCK[1:0]), interrupt interval (WTIN[1:0]), and function enable/disable (WTEN). Also there is WT interrupt flag bit (WTIFR).

11.4.5 Register Description for Watch Timer

WTCNT (Watch Timer Counter Register: Read Case) : 9FH

7	6	5	4	3	2	1	0
–	WTCNT6	WTCNT5	WTCNT4	WTCNT3	WTCNT2	WTCNT1	WTCNT0
–	R	R	R	R	R	R	R

Initial value : 00H

WTCNT[6:0] WT Counter

WTDR (Watch Timer Data Register: Write Case) : 9FH

7	6	5	4	3	2	1	0
WTCL	WTDR6	WTDR5	WTDR4	WTDR3	WTDR2	WTDR1	WTDR0
RW	W	W	W	W	W	W	W

Initial value : 7FH

WTCL Clear WT Counter

0 Free Run

1 Clear WT Counter (auto clear after 1 Cycle)

WTDR[6:0] Set WT period

WT Interrupt Interval=fwck/(2¹⁴ x(7bit WTDR Value+1))

NOTE)

1. Do not write "0" in the WTDR register.

WTCR (Watch Timer Control Register) : 9EH

7	6	5	4	3	2	1	0
WTEN	–	–	WTIFR	WTIN1	WTIN0	WTCK1	WTCK0
RW	–	–	RW	RW	RW	RW	RW

Initial value : 00H

WTEN Control Watch Timer

- 0 Disable
- 1 Enable

WTIFR When WT Interrupt occurs, this bit becomes '1'. For clearing bit, write '0' to this bit or auto clear by INT_ACK signal. Writing "1" has no effect.

- 0 WT Interrupt no generation
- 1 WT Interrupt generation

WTIN[1:0] Determine interrupt interval

WTIN1	WTIN0	Description
0	0	$f_{WCK}/2^7$
0	1	$f_{WCK}/2^{13}$
1	0	$f_{WCK}/2^{14}$
1	1	$f_{WCK}/(2^{14} \times (7\text{bit WTDR Value}+1))$

WTCK[1:0] Determine Source Clock

WTCK1	WTCK0	Description
0	0	f_{SUB}
0	1	$f_X/256$
1	0	$f_X/128$
1	1	$f_X/64$

NOTE)

1. f_X – System clock frequency (Where $f_X = 4.19\text{MHz}$)
2. f_{SUB} – Sub clock oscillator frequency (32.768kHz)
3. f_{WCK} – Selected Watch timer clock
4. f_{LCD} – LCD frequency (Where $f_X = 4.19\text{MHz}$, $WTCK[1:0] = '10'$; $f_{LCD} = 1024\text{Hz}$)

11.5 Timer 0

11.5.1 Overview

The 8-bit timer 0 consists of multiplexer, timer 0 counter register, timer 0 data register, timer 0 capture data register and timer 0 control register (T0CNT, T0DR, T0CDR, T0CR).

It has three operating modes:

- 8-bit timer/counter mode
- 8-bit PWM output mode
- 8-bit capture mode

The timer/counter 0 can be clocked by an internal or an external clock source (EC0). The clock source is selected by clock selection logic which is controlled by the clock selection bits (T0CK[2:0]).

- TIMER0 clock source: $f_x/2$, 4, 8, 32, 128, 512, 2048, EC0

In the capture mode, by EINT10, the data is captured into input capture data register (T0CDR). In timer/counter mode, whenever counter value is equal to T0DR, T0O port toggles. Also the timer 0 outputs PWM waveform through PWM0O port in the PWM mode.

T0EN	T0_PE	T0MS[1:0]	T0CK[2:0]	Timer 0
1	1	00	XXX	8 Bit Timer/Counter Mode
1	1	01	XXX	8 Bit PWM Mode
1	0	1X	XXX	8 Bit Capture Mode

Table 11-5. Timer 0 Operating Modes

11.5.2 8-Bit Timer/Counter Mode

The 8-bit timer/counter mode is selected by control register as shown in Figure 11.6.

The 8-bit timer have counter and data register. The counter register is increased by internal or external clock input. Timer 0 can use the input clock with one of 2, 4, 8, 32, 128, 512 and 2048 prescaler division rates (T0CK[2:0]). When the value of T0CNT and T0DR is identical in timer 0, a match signal is generated and the interrupt of Timer 0 occurs. T0CNT value is automatically cleared by match signal. It can be also cleared by software (T0CC).

The external clock (EC0) counts up the timer at the rising edge. If the EC0 is selected as a clock source by T0CK[2:0], EC0 port should be set to EC0 function by PFSR6[3:2] bits.

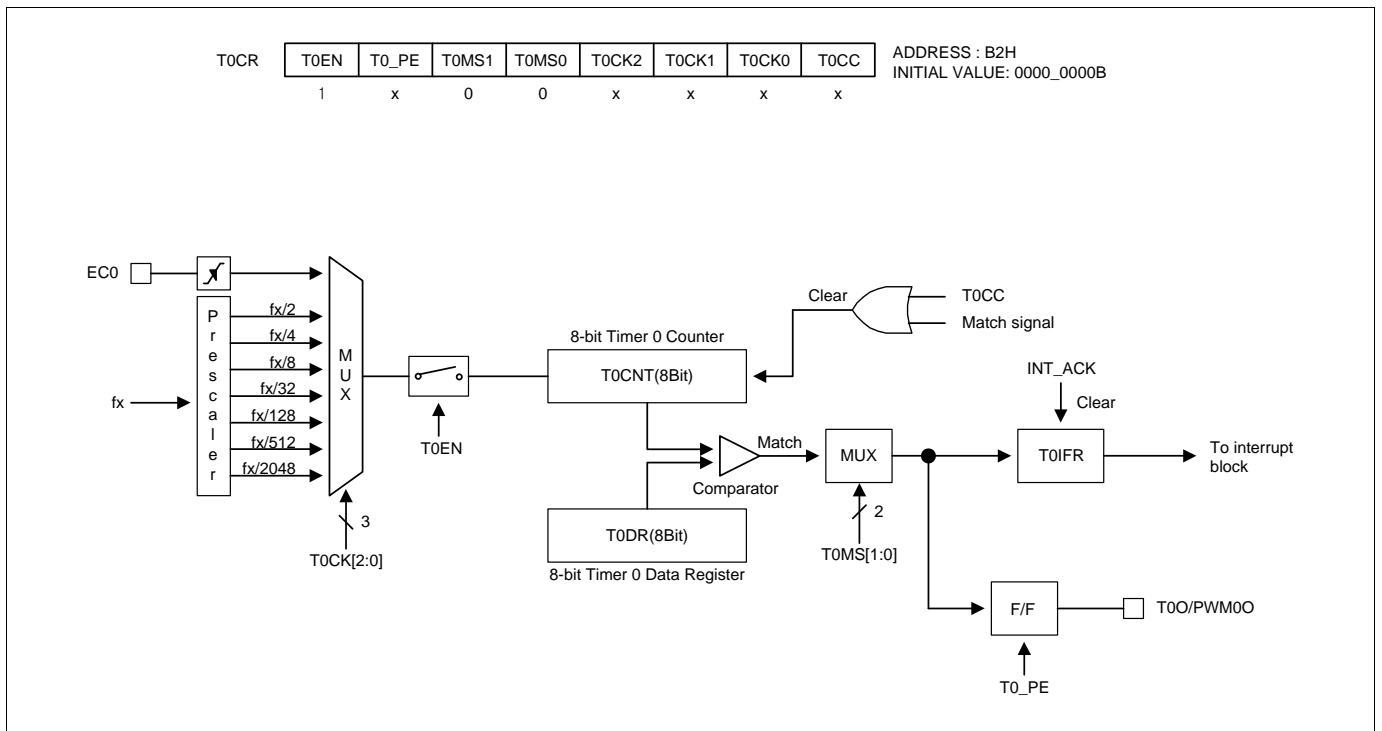

Figure 11-6. 8-Bit Timer/Counter Mode for Timer 0

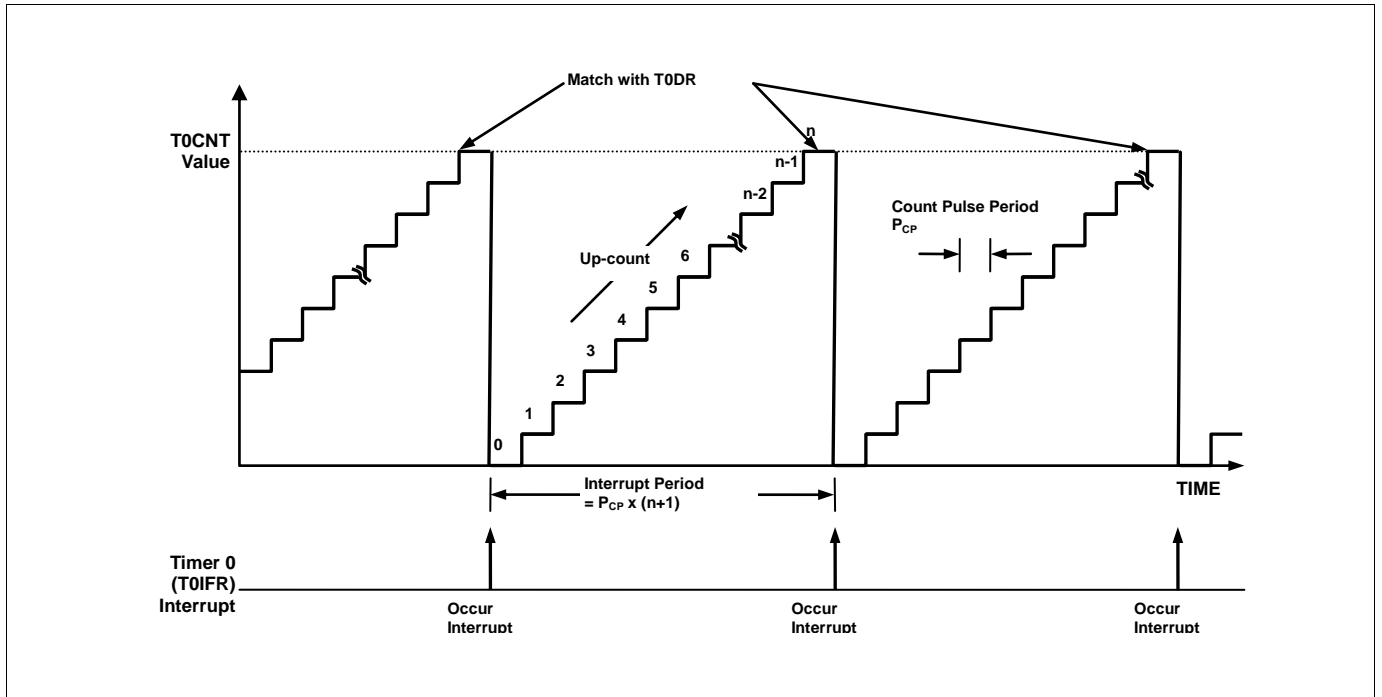

Figure 11-7. 8-Bit Timer/Counter 0 Example

11.5.3 8-Bit PWM Mode

The timer 0 has a high speed PWM (Pulse Width Modulation) function. In PWM mode, T0O/PWM00 pin outputs up to 8-bit resolution PWM output. This pin should be configured as a PWM output by setting T0_PE to '1' and the T0O/PWM00 function by PFSR6[1:0] bits. In the 8-bit timer/counter mode, a match signal is generated when the counter value is identical to the value of T0DR. When the value of T0CNT and T0DR is identical in timer 0, a match signal is generated and the interrupt of timer 0 occurs. In PWM mode, the match signal does not clear the counter. Instead, it runs continuously, overflowing at "FFH", and then continues incrementing from "00H". The timer 0 overflow interrupt is generated whenever a counter overflow occurs. T0CNT value is cleared by software (T0CC) bit.

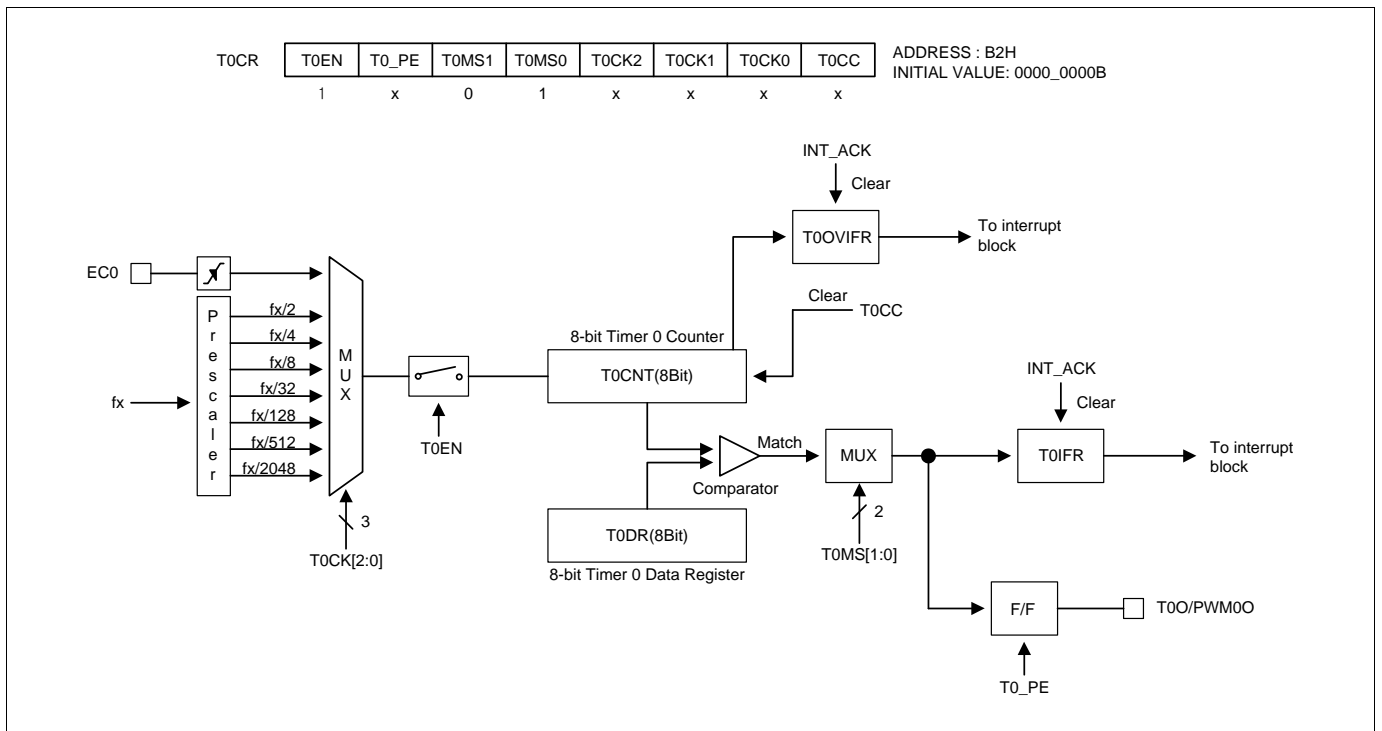

Figure 11-8. 8-Bit PWM Mode for Timer 0

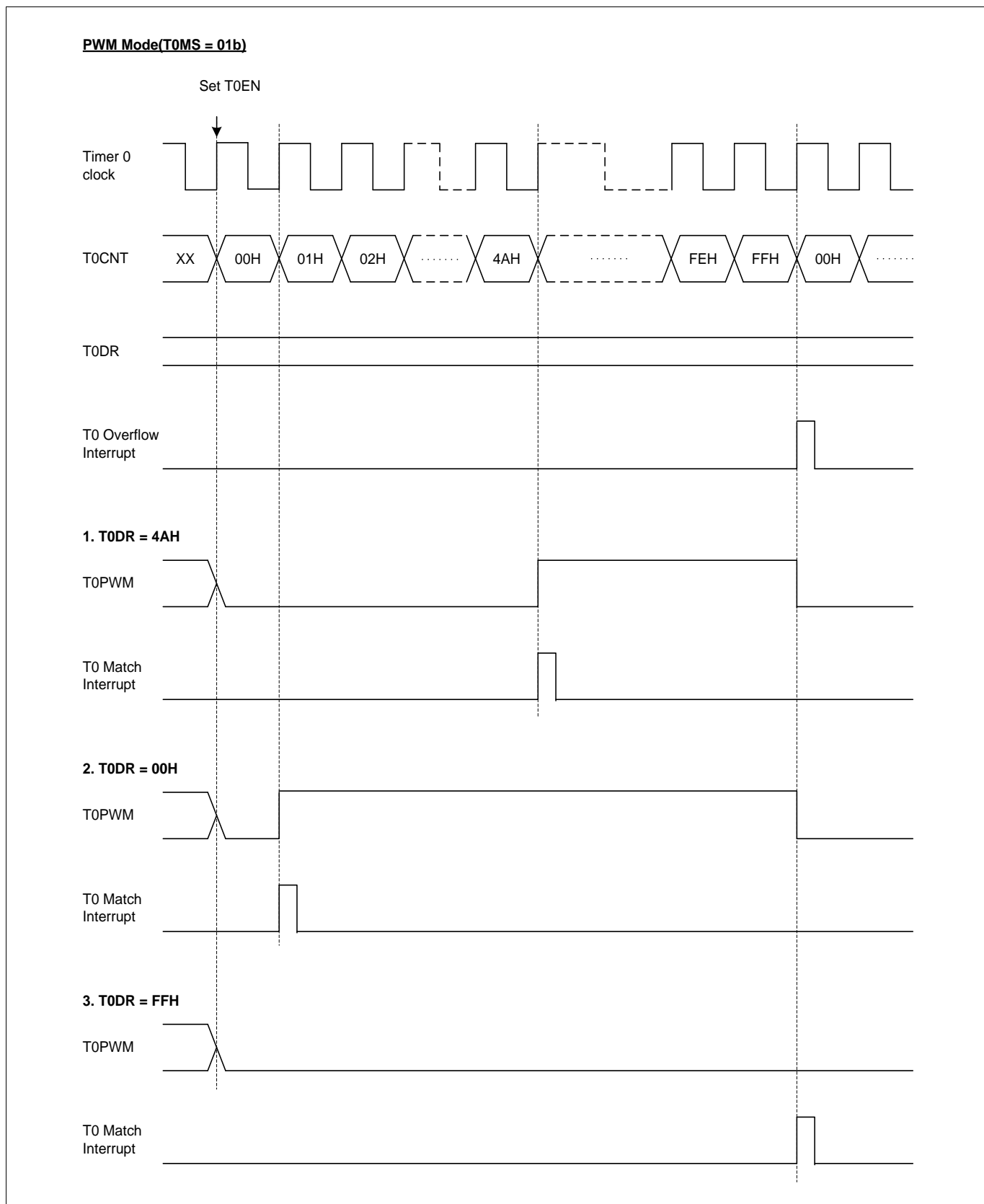

Figure 11-9. PWM Output Waveforms in PWM Mode for Timer 0

11.5.4 8-Bit Capture Mode

The timer 0 capture mode is set by T0MS[1:0] as '1x'. The clock source can use the internal/external clock. Basically, it has the same function as the 8-bit timer/counter mode and the interrupt occurs when T0CNT is equal to T0DR. T0CNT value is automatically cleared by match signal and it can be also cleared by software (T0CC).

This timer interrupt in capture mode is very useful when the pulse width of captured signal is wider than the maximum period of timer.

The capture result is loaded into T0CDR. In the timer 0 capture mode, timer 0 output (T0O) waveform is not available. According to EIEDGE1 and EIPOL1 registers setting, the external interrupt EINT10 function is chosen. Of course, the EINT10 pin must be set to an input port.

T0CDR and T0DR are in the same address. In the capture mode, reading operation reads T0CDR, not T0DR and writing operation will update T0DR.

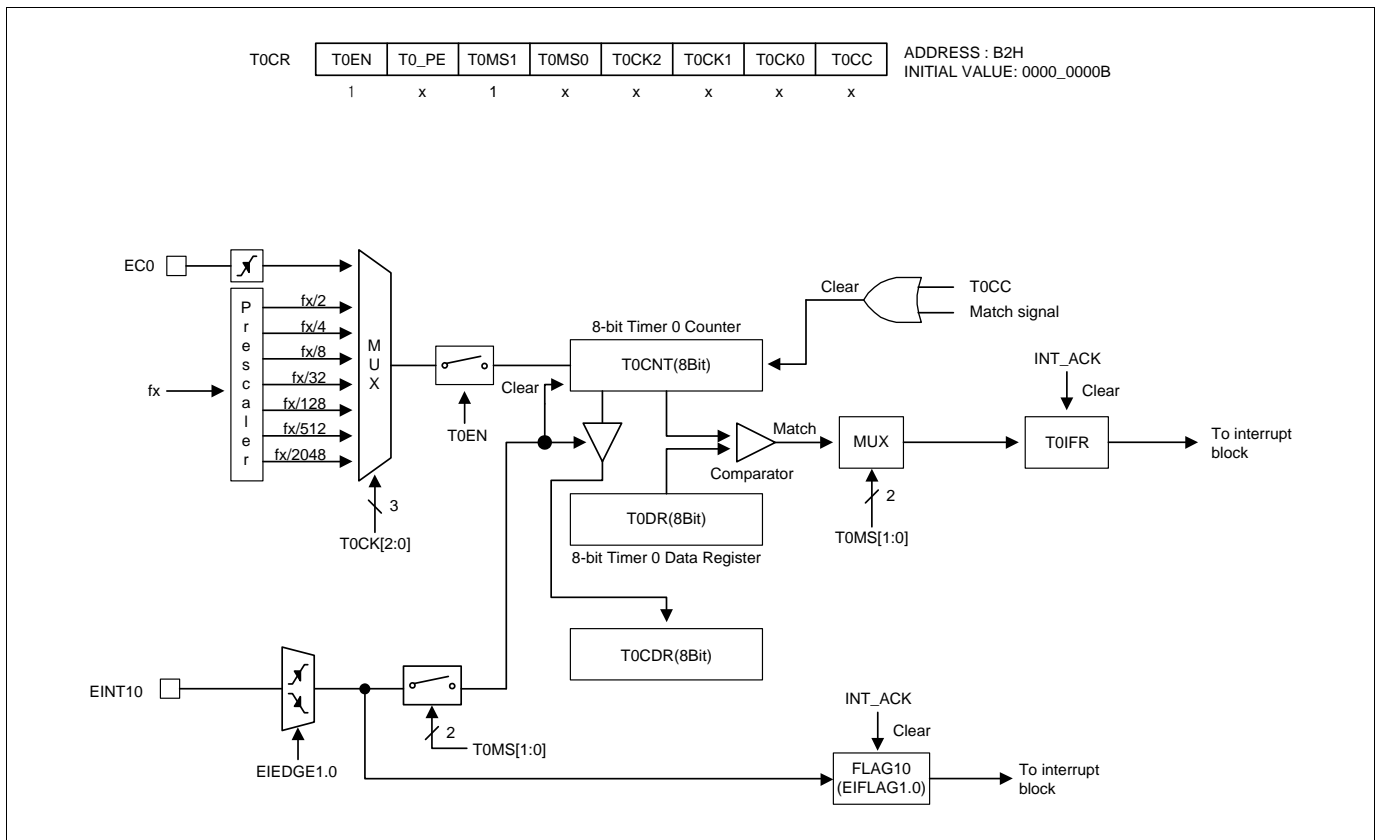

Figure 11-10. 8-Bit Capture Mode for Timer 0

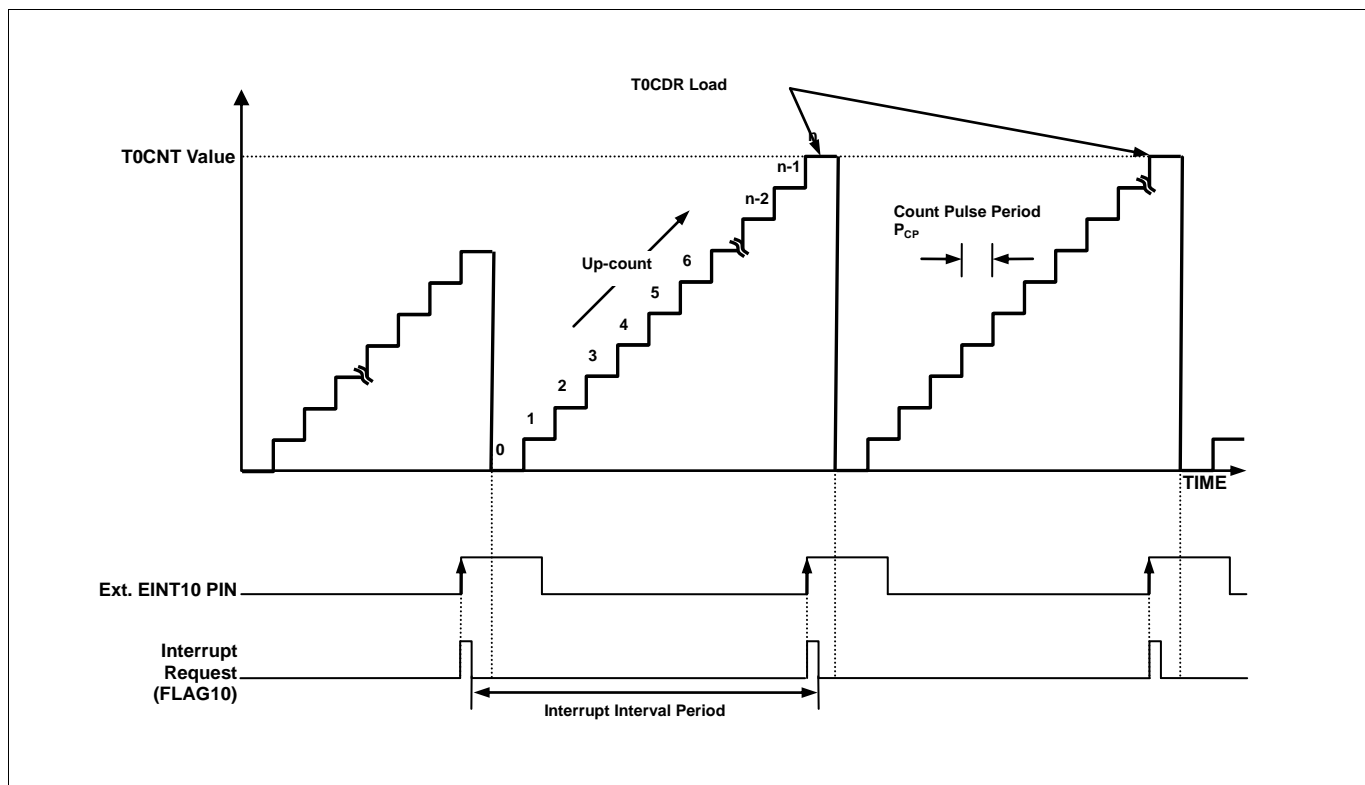

Figure 11-11. Input Capture Mode Operation for Timer 0

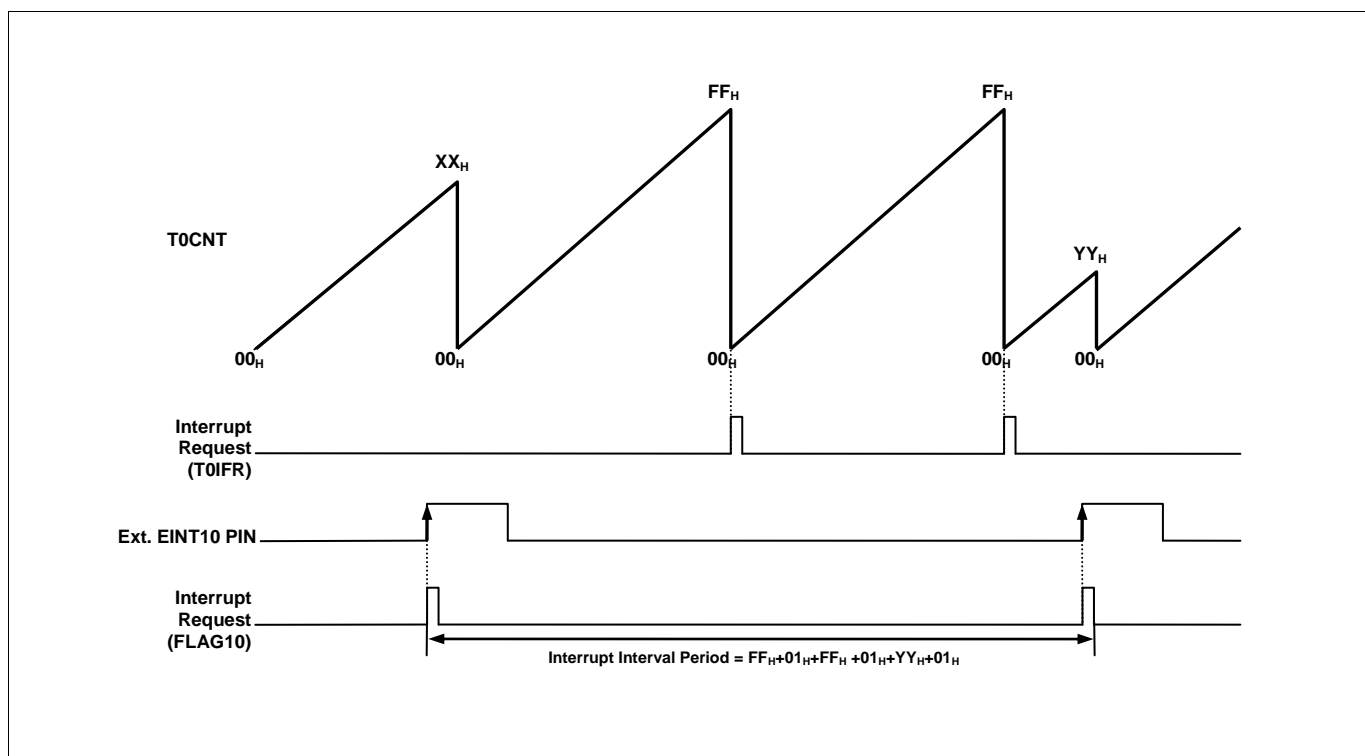

Figure 11-12. Express Timer Overflow in Capture Mode

11.5.5 Block Diagram

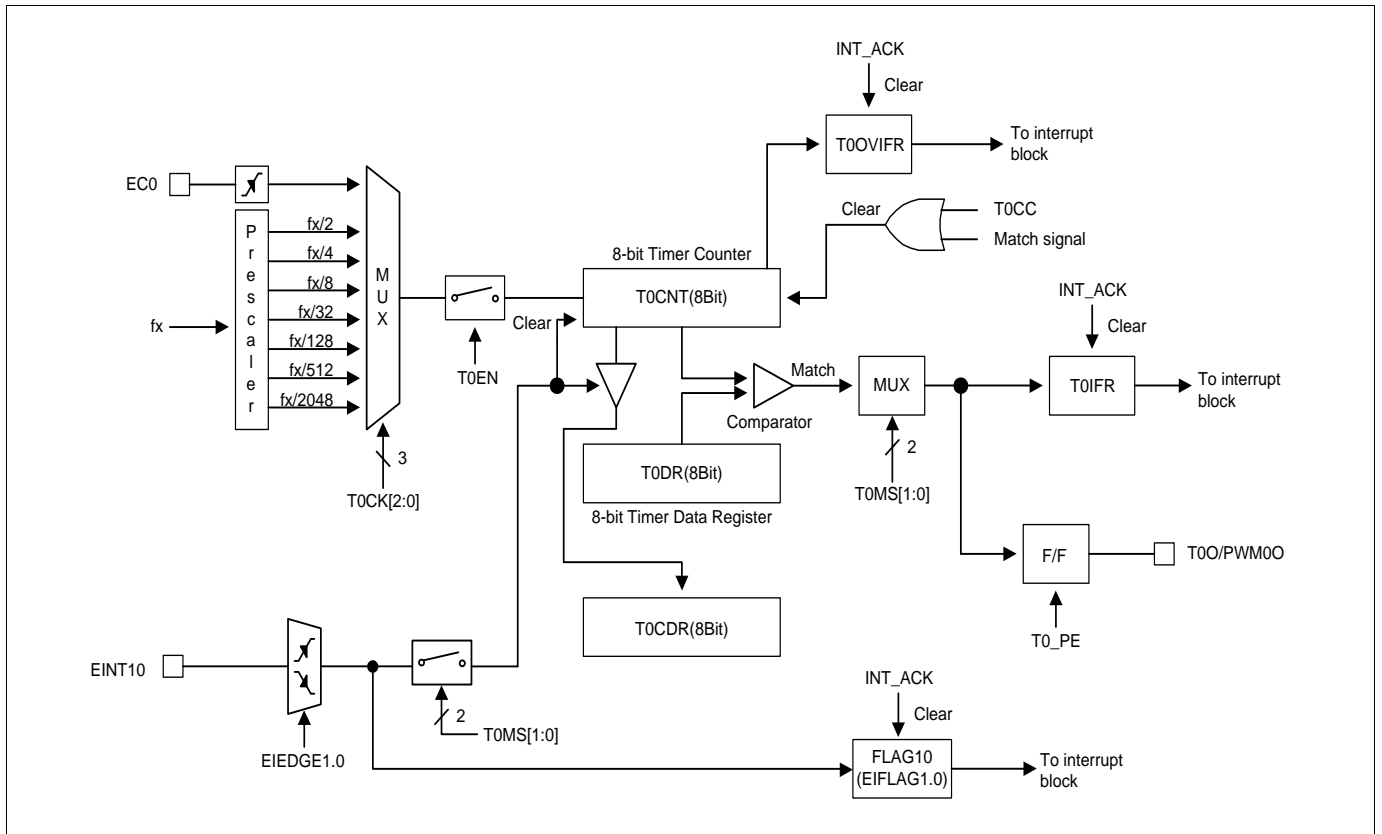

Figure 11-13. 8-Bit Timer 0 Block Diagram

11.5.6 Register Map

Name	Address	Dir	Default	Description
T0CNT	B3H	R	00H	Timer 0 Counter Register
T0DR	B4H	R/W	FFH	Timer 0 Data Register
T0CDR	B4H	R	00H	Timer 0 Capture Data Register
T0CR	B2H	R/W	00H	Timer 0 Control Register

Table 11-6. Timer 0 Register Map

11.5.7 Timer/Counter 0 Register Description

The timer/counter 0 register consists of timer 0 counter register (T0CNT), timer 0 data register (T0DR), timer 0 capture data register (T0CDR), and timer 0 control register (T0CR). T0IFR and T0OVIFR bits are in the timer interrupt flag register (TIFR).

11.5.8 Register Description for Timer/Counter 0

T0CNT (Timer 0 Counter Register) : B3H

7	6	5	4	3	2	1	0
T0CNT7	T0CNT6	T0CNT5	T0CNT4	T0CNT3	T0CNT2	T0CNT1	T0CNT0
R	R	R	R	R	R	R	R

Initial value : 00H

T0CNT[7:0] T0 Counter

T0DR (Timer 0 Data Register) : B4H

7	6	5	4	3	2	1	0
T0DR7	T0DR6	T0DR5	T0DR4	T0DR3	T0DR2	T0DR1	T0DR0
RW	RW	RW	RW	RW	RW	RW	RW

Initial value : FFH

T0DR[7:0] T0 Data

T0CDR (Timer 0 Capture Data Register: Read Case, Capture mode only) : B4H

7	6	5	4	3	2	1	0
T0CDR7	T0CDR6	T0CDR5	T0CDR4	T0CDR3	T0CDR2	T0CDR1	T0CDR0
R	R	R	R	R	R	R	R

Initial value : 00H

T0CDR[7:0] T0 Capture

T0CR (Timer 0 Control Register) : B2H

7	6	5	4	3	2	1	0
T0EN	T0_PE	T0MS1	T0MS0	T0CK2	T0CK1	T0CK0	T0CC
RW	RW	RW	RW	RW	RW	RW	RW

Initial value : 00H

- T0EN** Control Timer 0
 - 0 Timer 0 disable
 - 1 Timer 0 enable
- T0_PE** Control T0O/PWM0O Output port
 - 0 T0O/PWM0O Output disable
 - 1 T0O/PWM0O Output enable
- T0MS[1:0]** Control Timer 0 Operation Mode

T0MS1	T0MS0	Description
0	0	Timer/counter mode
0	1	PWM mode
1	x	Capture mode
- T0CK[2:0]** Select Timer 0 clock source. fx is a system clock frequency

T0CK2	T0CK1	T0CK0	Description
0	0	0	fx/2
0	0	1	fx/4
0	1	0	fx/8
0	1	1	fx/32
1	0	0	fx/128
1	0	1	fx/512
1	1	0	fx/2048
1	1	1	External Clock (EC0)
- T0CC** Clear timer 0 Counter
 - 0 No effect
 - 1 Clear the Timer 0 counter (When write, automatically cleared "0" after being cleared counter)

NOTE)

1. Match Interrupt is generated in Capture mode.

11.6 Timer 1

11.6.1 Overview

The 8-bit timer 1 consists of multiplexer, timer 1 counter register, timer 1 data high/low register, and timer 1 control register (T1CNT, T1DRH, T1DRL, T1CR) . For carrier mode, it has the carrier control register (CARCR).

It has two operating modes:

- 8-bit timer/counter mode
- 8-bit carrier mode

The timer/counter 1 can be clocked by an internal clock source. The clock source is selected by clock selection logic which is controlled by the clock selection bits (T1CK[1:0]).

- TIMER1 clock source: $f_x/1$, $f_x/2$, $f_x/4$, $f_x/8$

In the carrier mode, Timer 1 can be used to generate the carrier frequency or a remote controller signal. Timer 1 can output the comparison result between T1CNT & T1DRH/L and carrier frequency through REM port. T1CNT value is cleared by hardware.

T1EN	REM_PE	CAR1	T1CK[1:0]	CMOD	Timer 1
1	1	0	XXX	0	8 Bit Timer/Counter
1	1	1	XXX	0	8 Bit Carrier (One-shot)
1	1	1	XXX	1	8 Bit Carrier (Repeat)

Table 11-7. Timer 1 Operating Modes

11.6.2 8-Bit Timer/Counter 1 Mode

The 8-bit timer/counter mode is selected by control register as shown in Figure 11.14.

The 8-bit timer have counter and data register. The counter register is increased by internal clock source. Timer 1 can use the input clock with one of 1, 2, 4 and 8 prescaler division rates (T1CK[1:0]). When the value of T1CNT and T1DRH is identical in Timer 1, a match signal is generated and the interrupt of Timer 1 occurs. The match signal generates a timer 1 interrupt and clear the counter. The timer 1 interval can be output through REM port.

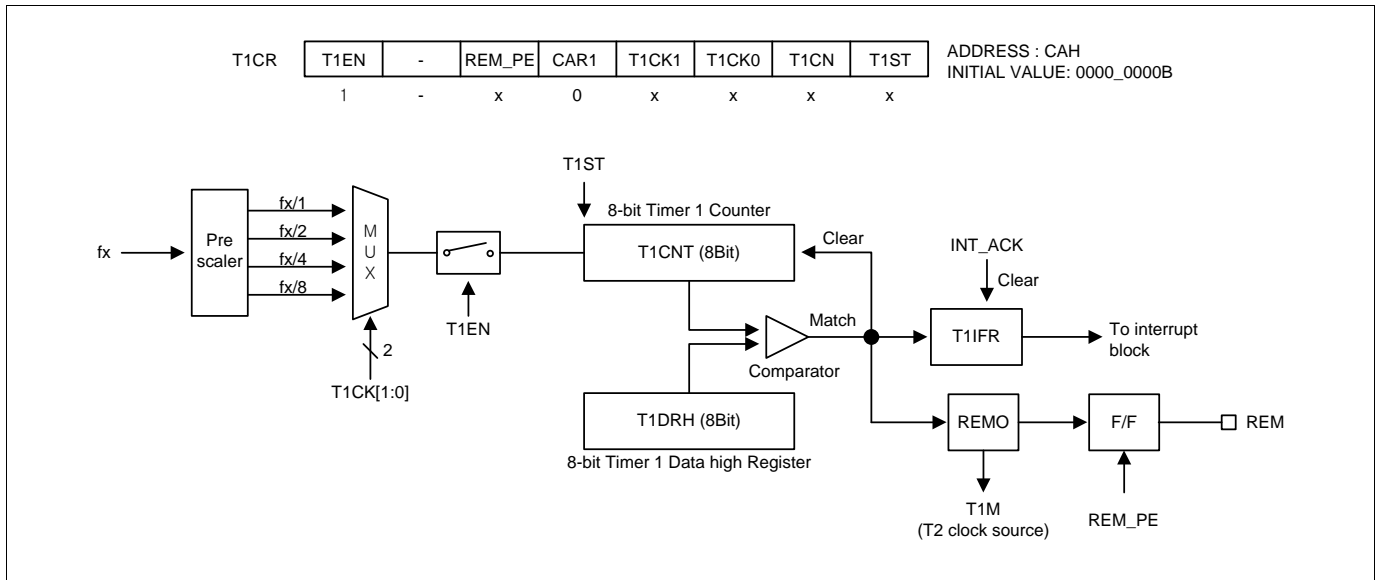

Figure 11-14. 8-Bit Timer/Counter Mode for Timer 1

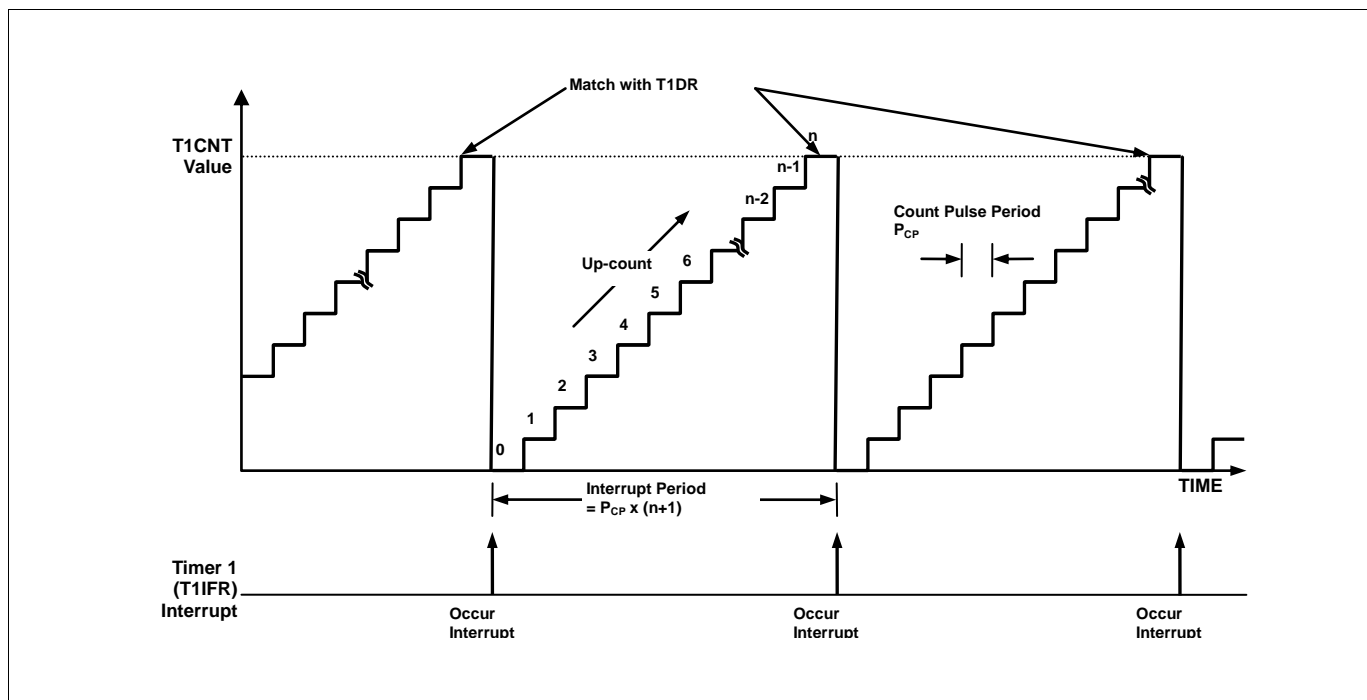

Figure 11-15. 8-Bit Timer/Counter 1 Example

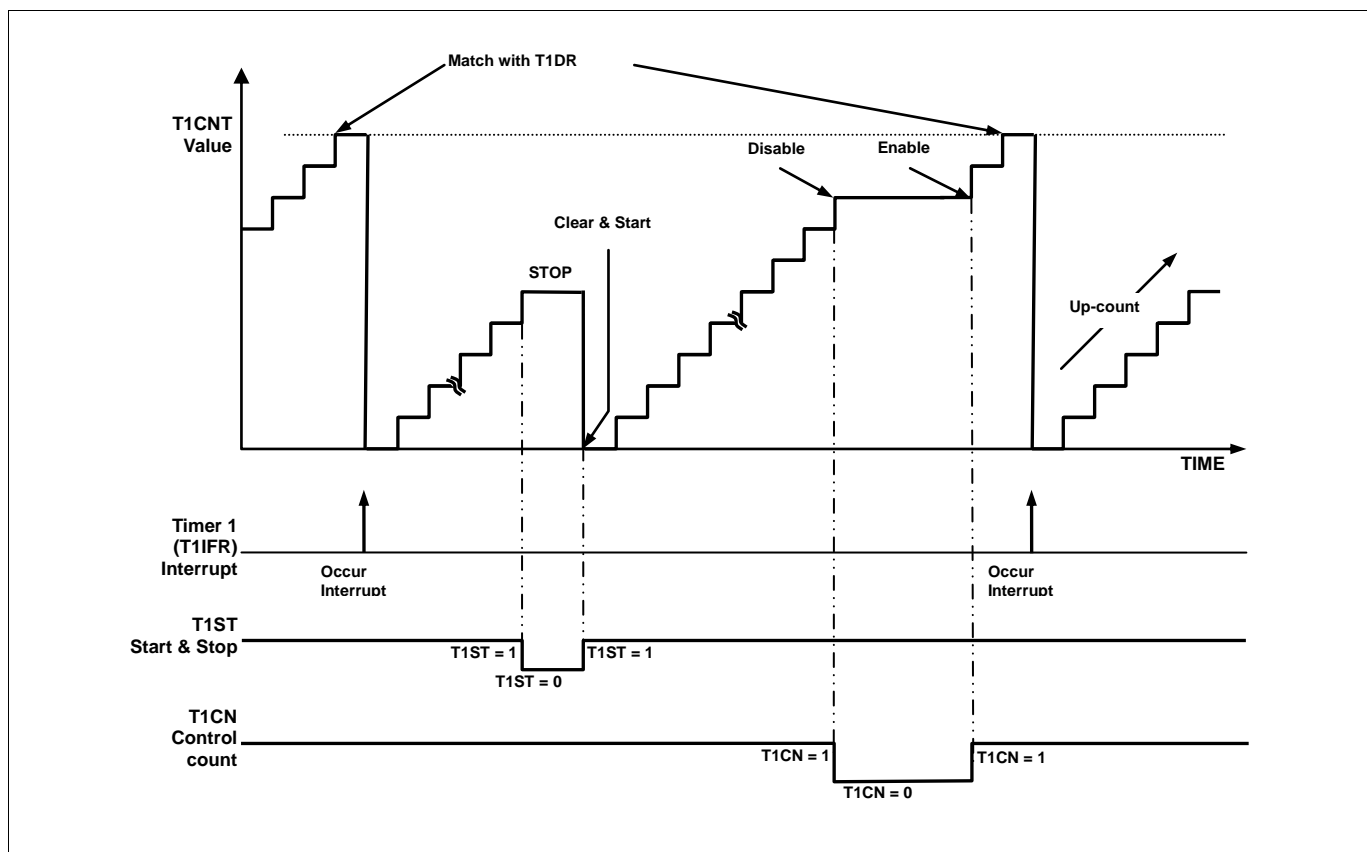

Figure 11-16. 8-Bit Timer/Counter 1 Counter Operation

11.6.3 8-Bit Timer 1 Carrier Frequency Mode

The carrier frequency and the pulse of data are calculated by the formula in the following sheet .The Figure 11.17 shows the block diagram of Timer 1 for carrier frequency mode.

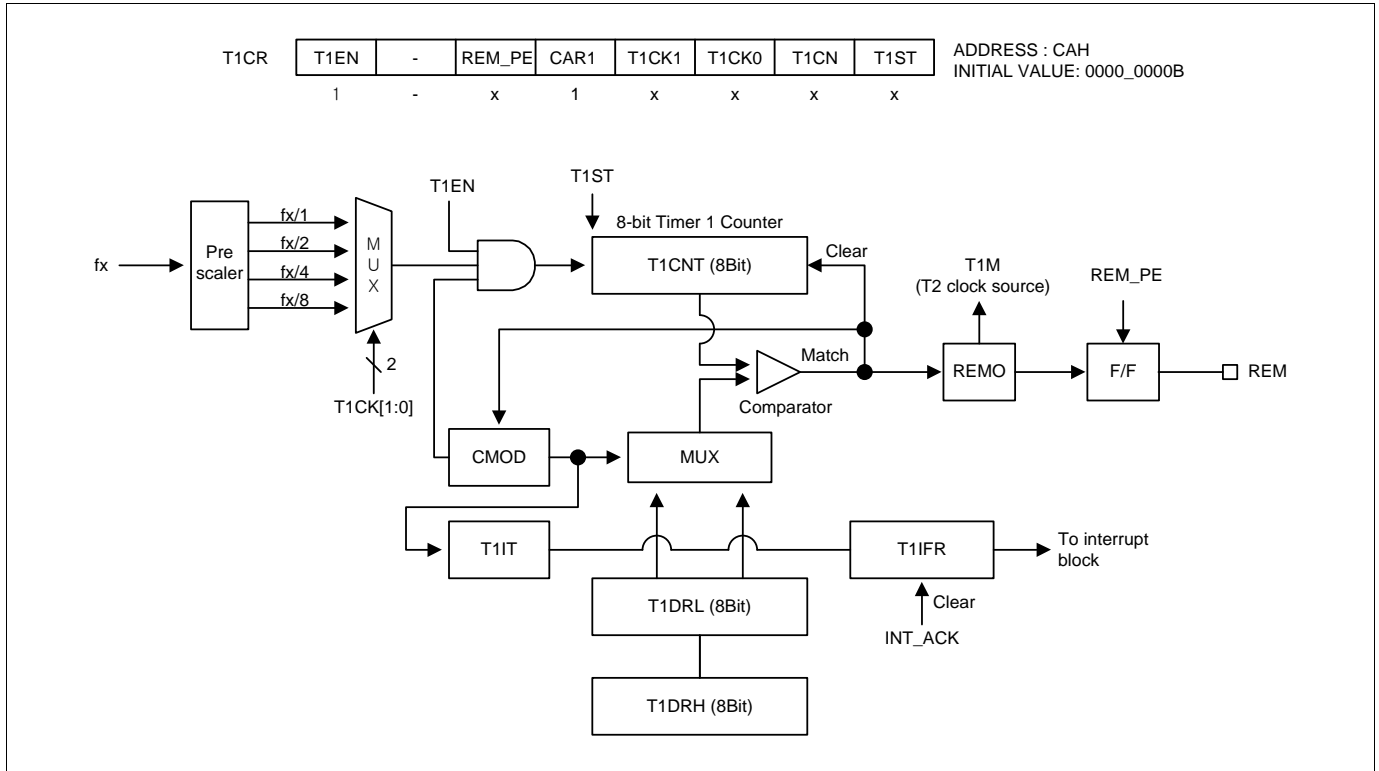
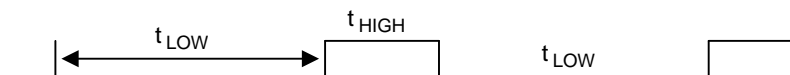

Figure 11-17. Carrier Mode for Timer 1

NOTE)

1. When one of T1DRH and T1DRL values is "00H", the carrier frequency generator (REM) output always becomes a "High" or "Low". At that time, Timer 1 Interrupt Flag Bit (T1IFR) is not set.

11.6.4 Carrier Output Pulse Width Calculations



To generate the above repeated waveform consisted of low period time (t_{LOW}), and high period time (t_{HIGH}).

When $REMO = 0$,

$$t_{LOW} = (T1DRL + 1) \times 1/f_{T1}, 0H < T1DRL < 100H, \text{ where } f_{T1} = \text{The selected clock.}$$

$$t_{HIGH} = (T1DRH + 1) \times 1/f_{T1}, 0H < T1DRH < 100H, \text{ where } f_{T1} = \text{The selected clock.}$$

When $REMO = 1$,

$$t_{LOW} = (T1DRH + 1) \times 1/f_{T1}, 0H < T1DRH < 100H, \text{ where } f_{T1} = \text{The selected clock.}$$

$$t_{HIGH} = (T1DRL + 1) \times 1/f_{T1}, 0H < T1DRL < 100H, \text{ where } f_{T1} = \text{The selected clock.}$$

To make $t_{LOW} = 24\mu s$ and $t_{HIGH} = 15\mu s$. $f_X = 4MHz$, $f_{T1} = 4MHz/4 = 1MHz$

When $REMO = 0$,

$$t_{LOW} = 24\mu s = (T1DRL + 1) / f_{T1} = (T1DRL + 1) \times 1\mu s, T1DRL = 22.$$

$$t_{HIGH} = 15\mu s = (T1DRH + 1) / f_{T1} = (T1DRH + 1) \times 1\mu s, T1DRH = 13.$$

When $REMO = 1$,

$$t_{LOW} = 24\mu s = (T1DRH + 1) / f_{T1} = (T1DRH + 1) \times 1\mu s, T1DRH = 22.$$

$$t_{HIGH} = 15\mu s = (T1DRL + 1) / f_{T1} = (T1DRL + 1) \times 1\mu s, T1DRL = 13.$$

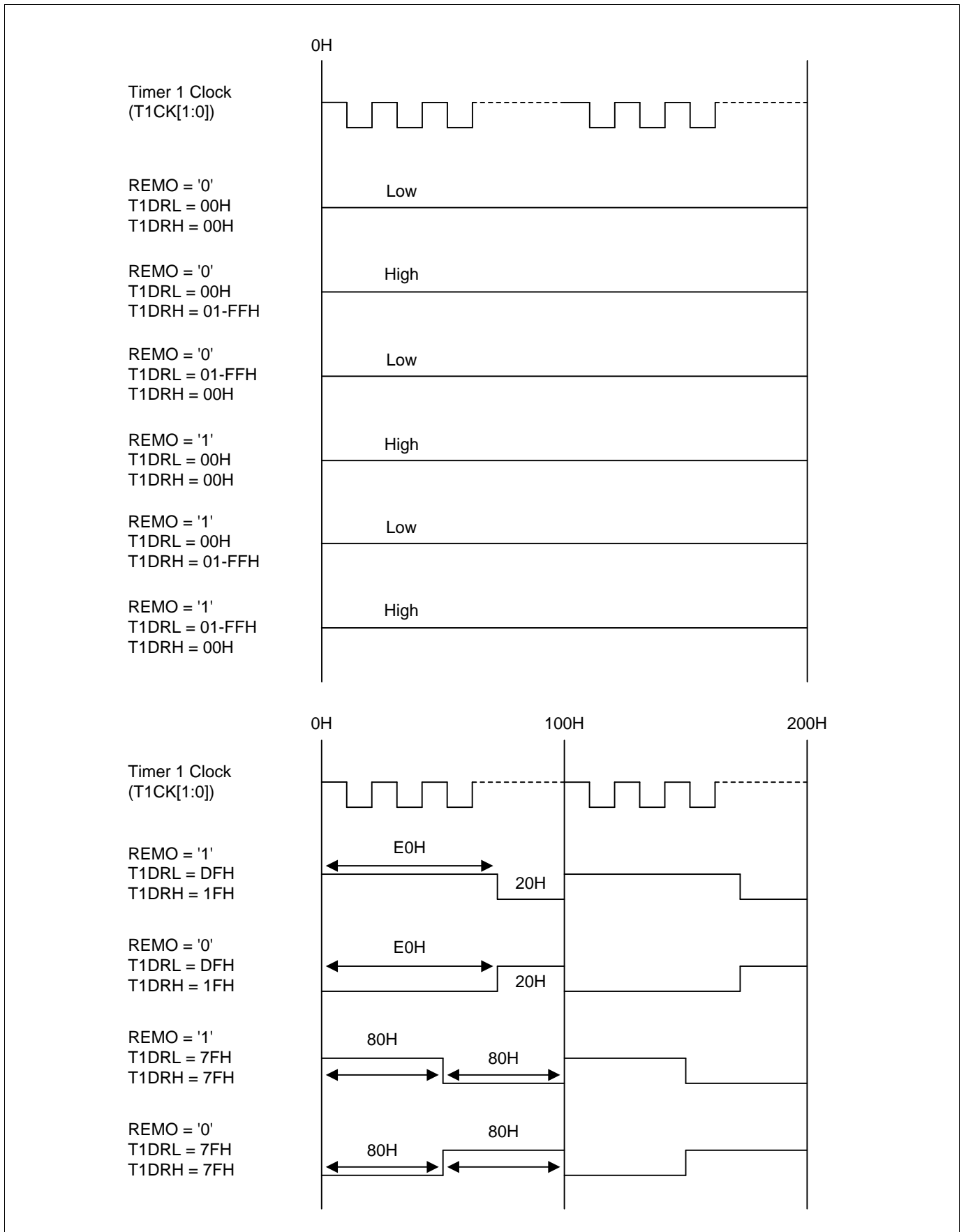

Figure 11-18. Carrier Output Waveforms in Repeat Mode for Timer 1

11.6.5 Block Diagram

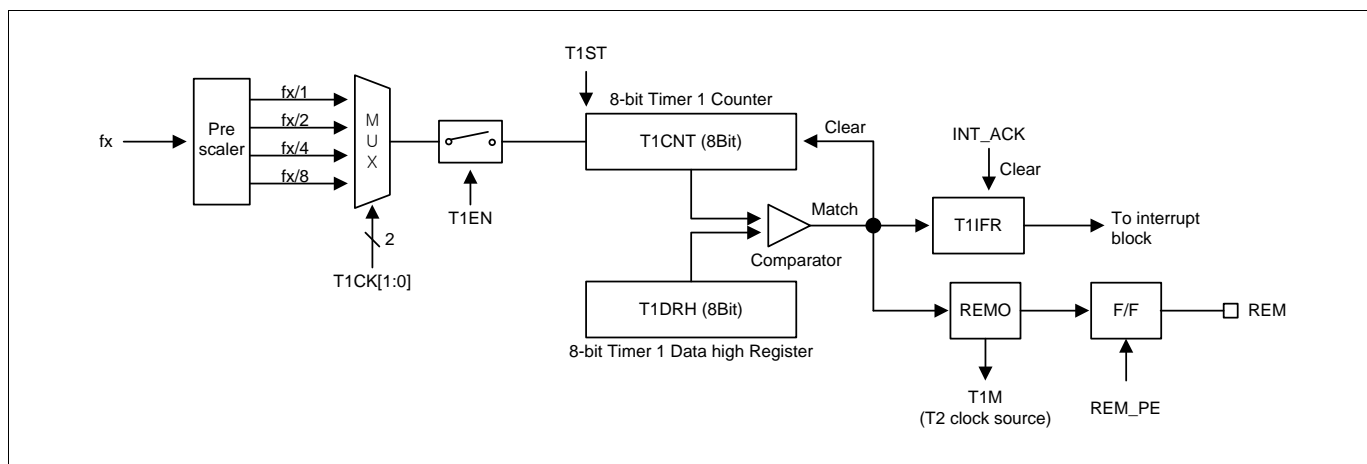

Figure 11-19. 8-Bit Timer 1 Block Diagram

11.6.6 Register Map

Name	Address	Dir	Default	Description
T1CNT	CBH	R	00H	Timer 1 Counter Register
T1DRH	CDH	R/W	FFH	Timer 1 Data High Register
T1DRL	CCH	R/W	FFH	Timer 1 Data Low Register
T1CR	CAH	R/W	00H	Timer 1 Control Register
CARCR	CEH	R/W	00H	Carrier Control Register

Table 11-8. Timer 1 Register Map

11.6.7 Timer/Counter 1 Register Description

The timer/counter 1 register consists of timer 1 counter register (T1CNT), timer 1 data high register (T1DRH), timer 1 data low register (T1DRL), timer 1 control register (T1CR) and carrier control register (CARCR). T1IFR bit is in the timer interrupt flag register (TIFR).

11.6.8 Register description for Timer/Counter 1

T1CNT (Timer 1 Counter Register) : CBH

7	6	5	4	3	2	1	0
T1CNT7	T1CNT6	T1CNT5	T1CNT4	T1CNT3	T1CNT2	T1CNT1	T1CNT0
R	R	R	R	R	R	R	R

Initial value : 00H

T1CNT[7:0] T1 Counter

T1DRH (Timer 1 Data High Register) : CDH

7	6	5	4	3	2	1	0
T1DRH7	T1DRH6	T1DRH5	T1DRH4	T1DRH3	T1DRH2	T1DRH1	T1DRH0
RW	RW	RW	RW	RW	RW	RW	RW

Initial value : FFH

T1DRH[7:0] T1 Data High

T1DRL (Timer 1 Data Low Register: Carrier mode only) : CCH

7	6	5	4	3	2	1	0
T1DRL7	T1DRL6	T1DRL5	T1DRL4	T1DRL3	T1DRL2	T1DRL1	T1DRL0
RW	RW	RW	RW	RW	RW	RW	RW

Initial value : FFH

T1DRL[7:0] T1 Data Low

T1CR (Timer 1 Control Register) : CAH

7	6	5	4	3	2	1	0
T1EN	–	REM_PE	CAR1	T1CK1	T1CK0	T1CN	T1ST
RW	–	RW	RW	RW	RW	RW	RW

Initial value : 00H

- T1EN** Control Timer 1
 0 Timer 1 disable
 1 Timer 1 enable
- REM_PE** REM Output Port
 0 REM output disable
 1 REM output enable
- CAR1** Control Timer 1 Operation mode
 0 Timer/counter mode
 1 Carrier mode
- T1CK[1:0]** Select Timer 1 clock source. fx is system clock frequency

T1CK1	T1CK0	Description
0	0	fx/1
0	1	fx/2
1	0	fx/4
1	1	fx/8
- T1CN** Control Timer 1 Counter pause/continue
 0 Temporary count stop
 1 Continue count
- T1ST** Control Timer 1 start/stop
 0 Counter stop
 1 Clear counter and start

CARCR (Carrier Control Register: Carrier mode only) : CEH

7	6	5	4	3	2	1	0
–	–	T1IT1	T1IT0	–	–	CMOD	REMO
–	–	RW	RW	–	–	RW	RW

Initial value : 00H

- T1IT[1:0]** T1 Interrupt Time Select

T1IT1	T1IT0	Description
0	0	Elapsed time for low data value
0	1	Elapsed time for high data value
1	0	Elapsed time for low and high data value
1	1	Not available
- CMOD** Carrier Frequency Mode Select
 0 One-shot mode
 1 Repeating mode
- REMO** REM Output Control
 0 T1DRL→ Low width, T1DRH→ High width
 1 T1DRL→ High width, T1DRH→ Low width

11.7 Timer 2

11.7.1 Overview

The 16-bit timer 2 consists of multiplexer, timer 2 counter register high/low, timer 2 data register high/low, and timer 2 control register (T2CNTH, T2CNTL, T2DRH, T2DRL, T2CR). It can be used as an internal 16-bit timer/ counter 2 without a port output function.

The 16-bit timer 2 is able to use the divided clock of the system clock selected from prescaler output. T1M (timer 1 match signal) can be also used as the clock source of Timer 2.

11.7.2 Block Diagram

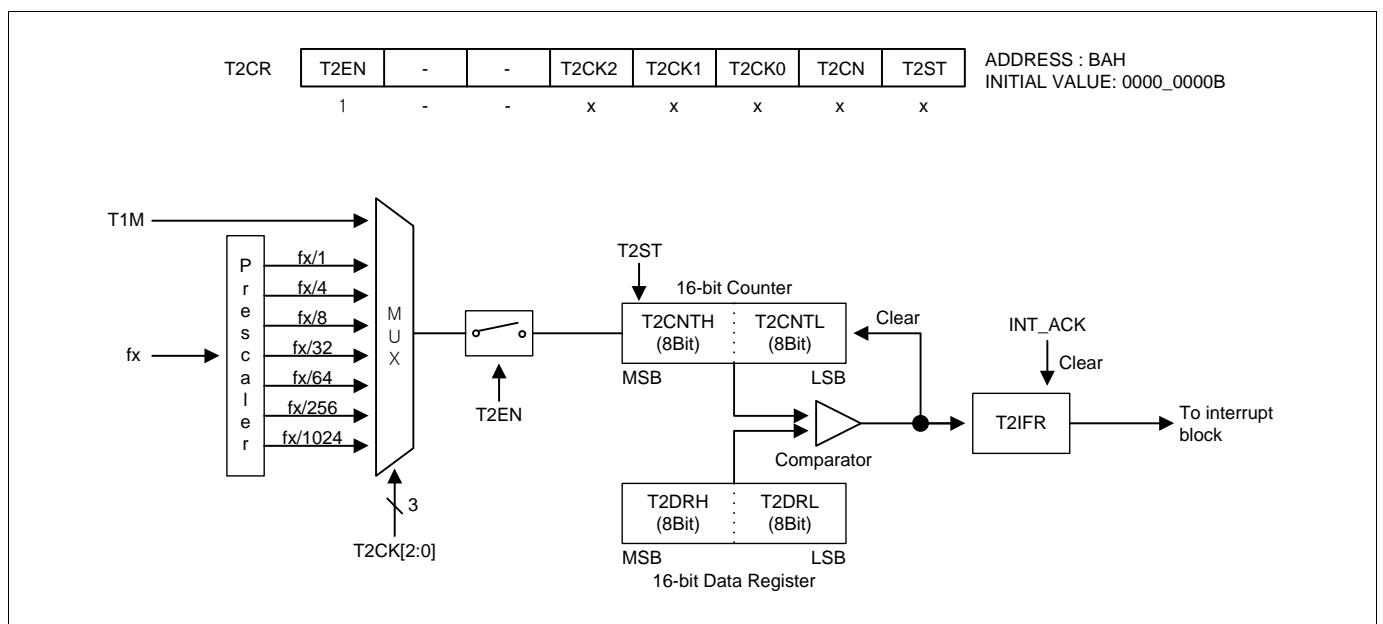

Figure 11-20. 16-Bit Timer 2 Block Diagram

11.7.3 Register Map

Name	Address	Dir	Default	Description
T2CNTH	BDH	R	00H	Timer 2 Counter High Register
T2CNTL	BCH	R	00H	Timer 2 Counter Low Register
T2DRH	BFH	R/W	FFH	Timer 2 Data High Register
T2DRL	BEH	R/W	FFH	Timer 2 Data Low Register
T2CR	BAH	R/W	00H	Timer 2 Control Register

Table 11-9. Timer 2 Register Map

11.7.4 Timer/Counter 2 Register Description

The timer/counter 2 register consists of timer 2 counter high register (T2CNTH), timer 2 counter low register (T2CNTL), timer 2 data high register (T2DRH), timer 2 data low register (T2DRL), and timer 2 control register (T2CR). T2IFR bit is in the timer interrupt flag register (TIFR).

11.7.5 Register Description for Timer/Counter 2

T2CNTH (Timer 2 Counter High Register) : BDH

7	6	5	4	3	2	1	0
T2CNTH7	T2CNTH6	T2CNTH5	T2CNTH4	T2CNTH3	T2CNTH2	T2CNTH1	T2CNTH0
R	R	R	R	R	R	R	R

Initial value : 00H

T2CNTH[7:0] T2 Counter High

T2CNTL (Timer 2 Counter Low Register) : BCH

7	6	5	4	3	2	1	0
T2CNTL7	T2CNTL6	T2CNTL5	T2CNTL4	T2CNTL3	T2CNTL2	T2CNTL1	T2CNTL0
R	R	R	R	R	R	R	R

Initial value : 00H

T2CNTL[7:0] T2 Counter Low

T2DRH (Timer 2 Data High Register) : BFH

7	6	5	4	3	2	1	0
T2DRH7	T2DRH6	T2DRH5	T2DRH4	T2DRH3	T2DRH2	T2DRH1	T2DRH0
RW	RW	RW	RW	RW	RW	RW	RW

Initial value : FFH

T2DRH[7:0] T2 Data High

T2DRL (Timer 2 Data Low Register) : BEH

7	6	5	4	3	2	1	0
T2DRL7	T2DRL6	T2DRL5	T2DRL4	T2DRL3	T2DRL2	T2DRL1	T2DRL0
RW	RW	RW	RW	RW	RW	RW	RW

Initial value : FFH

T2DRL[7:0] T2 Data Low

T2CR (Timer 2 Control Register) : BAH

7	6	5	4	3	2	1	0
T2EN	-	-	T2CK2	T2CK1	T2CK0	T2CN	T2ST
RW	-	-	RW	RW	RW	RW	RW

Initial value : 00H

- T2EN** Control Timer 2
 - 0 Timer 2 disable
 - 1 Timer 2 enable
- T2CK[2:0]** Select Timer 2 clock source. fx is main system clock frequency

T2CK2	T2CK1	T2CK0	Description
0	0	0	T1M
0	0	1	fx/1
0	1	0	fx/4
0	1	1	fx/8
1	0	0	fx/32
1	0	1	fx/64
1	1	0	fx/256
1	1	1	fx/1024
- T2CN** Control Timer 2 Counter pause/continue
 - 0 Temporary count stop
 - 1 Continue count
- T2ST** Control Timer 2 start/stop
 - 0 Counter stop
 - 1 Clear counter and start

11.8 Timer 3

11.8.1 Overview

The 16-bit timer 3 consists of multiplexer, timer 3 counter high/low register, timer 3 data high/low register, timer 3 capture data high/low register, and timer 3 control register (T3CNTH, T3CNTL, T3DRH, T3DRL, T3CDRH, T3CDRL, T3CR).

It has three operating modes:

- 16-bit timer/counter mode
- 16-bit PWM output mode
- 16-bit capture mode

The timer/counter can be clocked by an internal or an external clock source (EC3). The clock source is selected by clock selection logic which is controlled by the clock selection bits (T3CK[2:0]).

- TIMER3 clock source: $f_x/1, 2, 16, 64, 256, 512, 1024$ and EC3

In the capture mode, by EINT13, the data is captured into input capture data high/low register (T3CDRH, T3CDRL). Timer 3 outputs the comparison result between counter and data register through T3O port in 16-bit timer/counter mode. Also Timer 3 outputs PWM waveform through PWM3O port in the PWM mode.

T3EN	T3_PE	T3MS[1:0]	T3CK[2:0]	Timer 3
1	1	00	XXX	16 Bit Timer/Counter Mode
1	1	01	XXX	16 Bit PWM Mode
1	0	1X	XXX	16 Bit Capture Mode

Table 11-10. Timer 3 Operating Modes

11.8.2 16-Bit Timer/Counter Mode

The 16-bit timer/counter mode is selected by control register as shown in Figure 11.21.

The 16-bit timer have counter and data register. The counter register is increased by internal or external clock input.

Timer 3 can use the input clock with one of 1, 2, 16, 64, 256, 512 and 1024 prescaler division rates (T3CK[2:0]).

A 16-bit timer/counter register T3CNTH, T3CNTL are incremented from 0000H to FFFFH until it matches T3DRH, T3DRL and then cleared to 0000H. The match signal output generates the Timer 3 Interrupt. The T3CNTH, T3CNTL value is automatically cleared by match signal. It can be also cleared by software (T3CC).

The external clock (EC3) counts up the timer at the rising edge. If the EC3 is selected as a clock source by T3CK[2:0], EC3 port should be set to the EC3 function by PFSR0[1:0] bits.

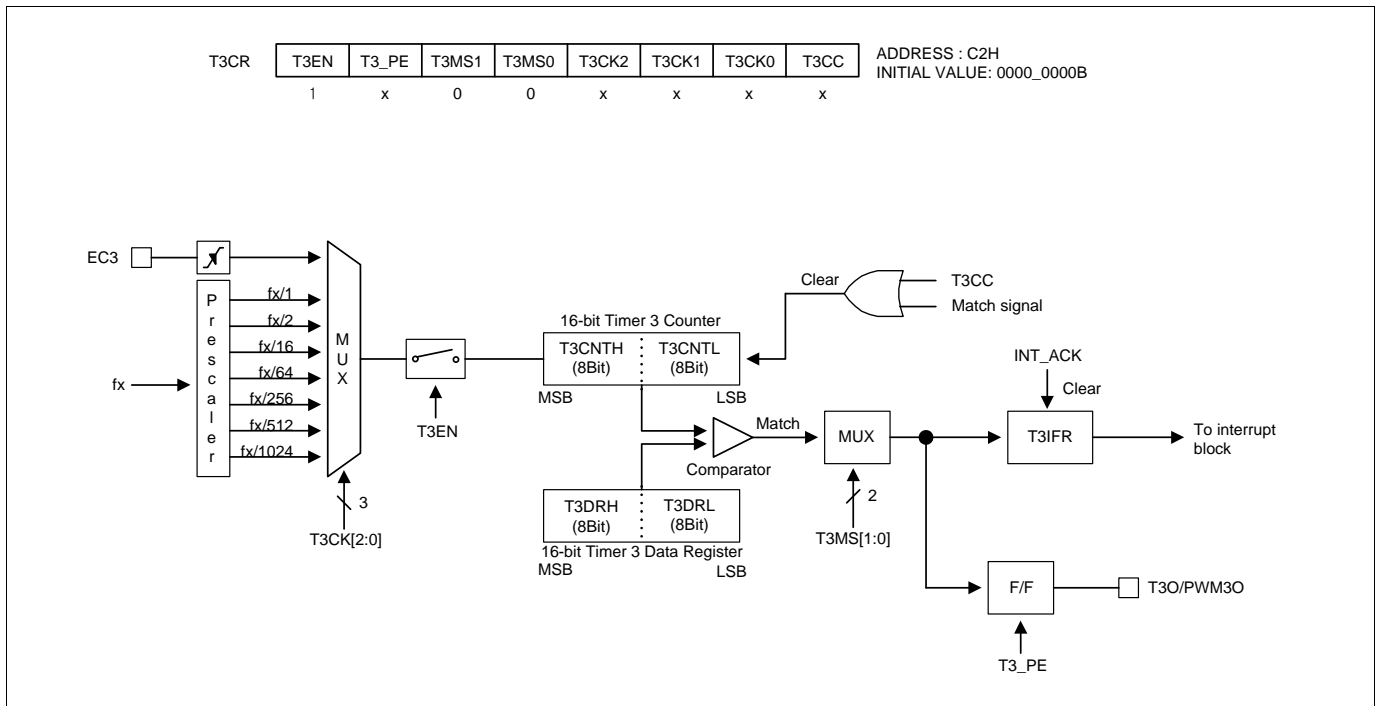

Figure 11-21. 16-Bit Timer/Counter Mode for Timer 3

11.8.3 16-Bit PWM Mode

The 16-bit timer 3 has a high speed PWM (Pulse Width Modulation) function. In PWM mode, T3O/PWM3O pin outputs up to 16-bit resolution PWM output. This pin should be configured as a PWM output by setting T3_PE to '1' and the T3O/PWM3O function by PFSR02 bit. As in the 16-bit timer/counter mode, a match signal is generated when the counter value is identical to the value of T3DRH/L. When the value of T3CNTH, T3CNTL and the value of T3DRH, T3DRL are identical in Timer 3 respectively, a match signal is generated and the interrupt of Timer 3 occurs. In PWM mode, the match signal does not clear the counter. Instead, it runs continuously, overflowing at "FFFFH", and then continues incrementing from "0000H". The timer 3 overflow interrupt is generated whenever a counter overflow occurs. The T3CNTH, T3CNTL values are cleared by software (T3CC) bit.

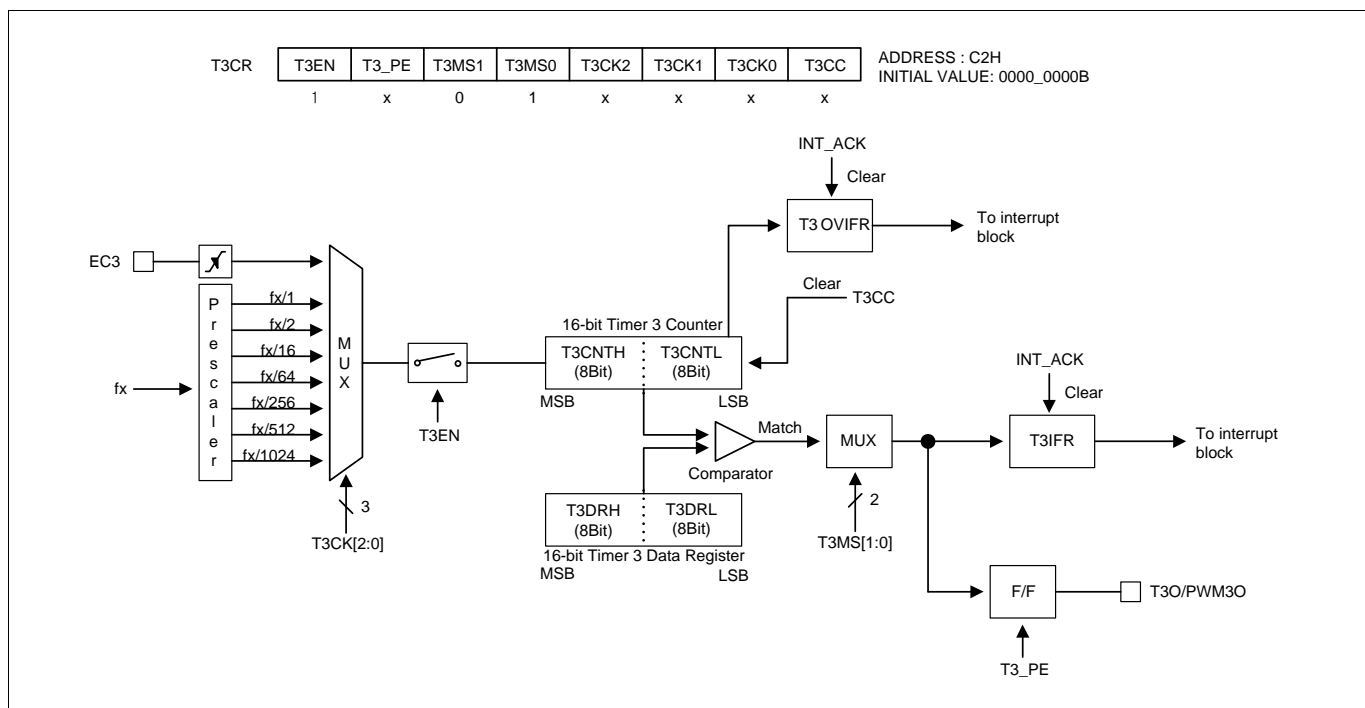

Figure 11-22. 16-Bit PWM Mode for Timer 3

11.8.4 16-Bit Capture Mode

The 16-bit timer 3 capture mode is set by T3MS[1:0] as '1X'. The clock source can use the internal/external clock. Basically, it has the same function as the 16-bit timer/counter mode and the interrupt occurs when T3CNTH/L is equal to T3DRH/L. The T3CNTH, T3CNTL values are automatically cleared by match signal. It can be also cleared by software (T3CC).

This timer interrupt in capture mode is very useful when the pulse width of captured signal is wider than the maximum period of timer.

The capture result is loaded into T3CDRH, T3CDRL.

According to the EIEDGE1 and EIPOL1 register setting, the external interrupt EINT13 function is chosen.

T3CDRH, T3CDRL and T3DRH, T3DRL are in same address respectively. In the capture mode, reading operation reads the T3CDRH, T3CDRL, not T3DRH, T3DRL and writing operation will update T3DRH and T3DRL.

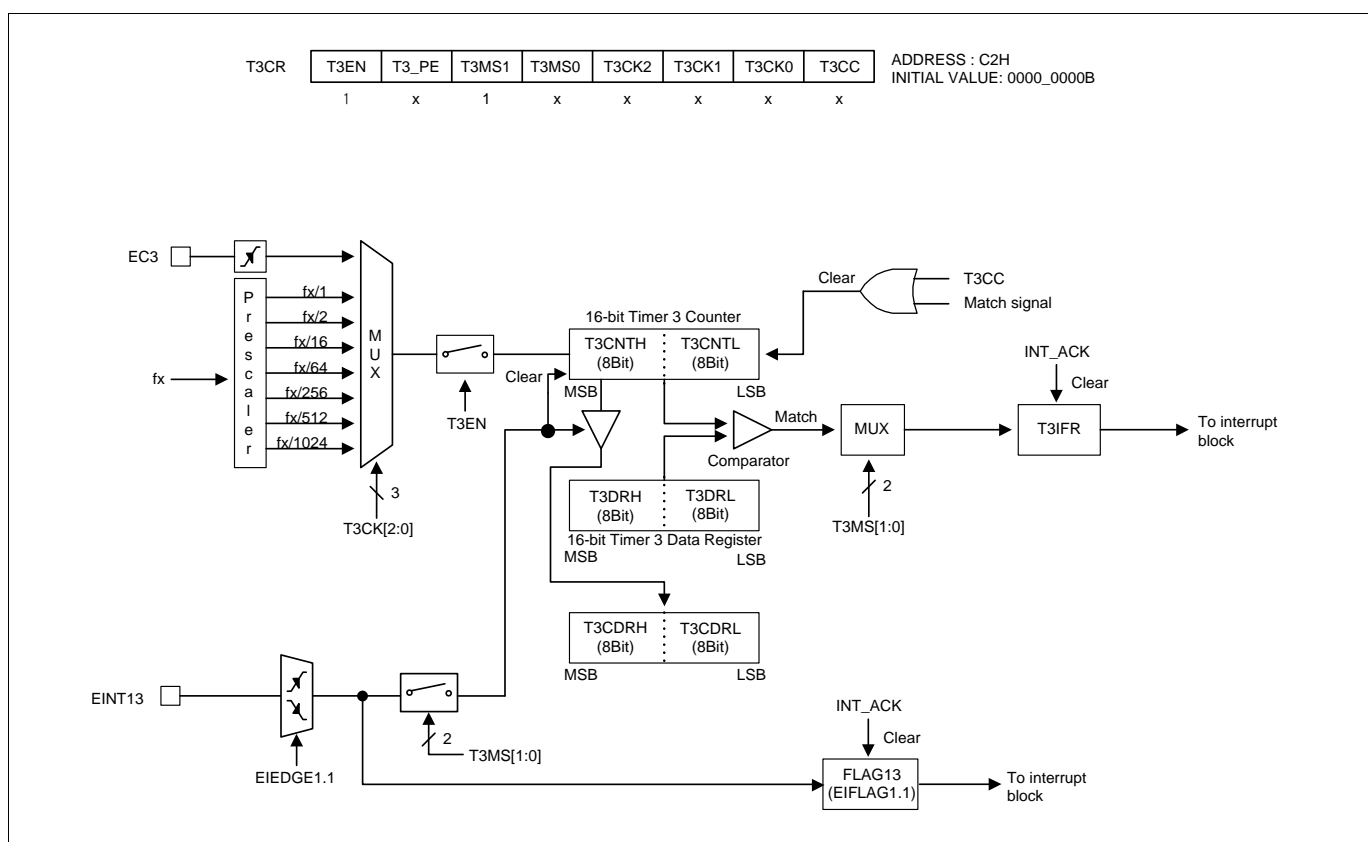

Figure 11-23. 16-Bit Capture Mode for Timer 3

11.8.5 Block Diagram

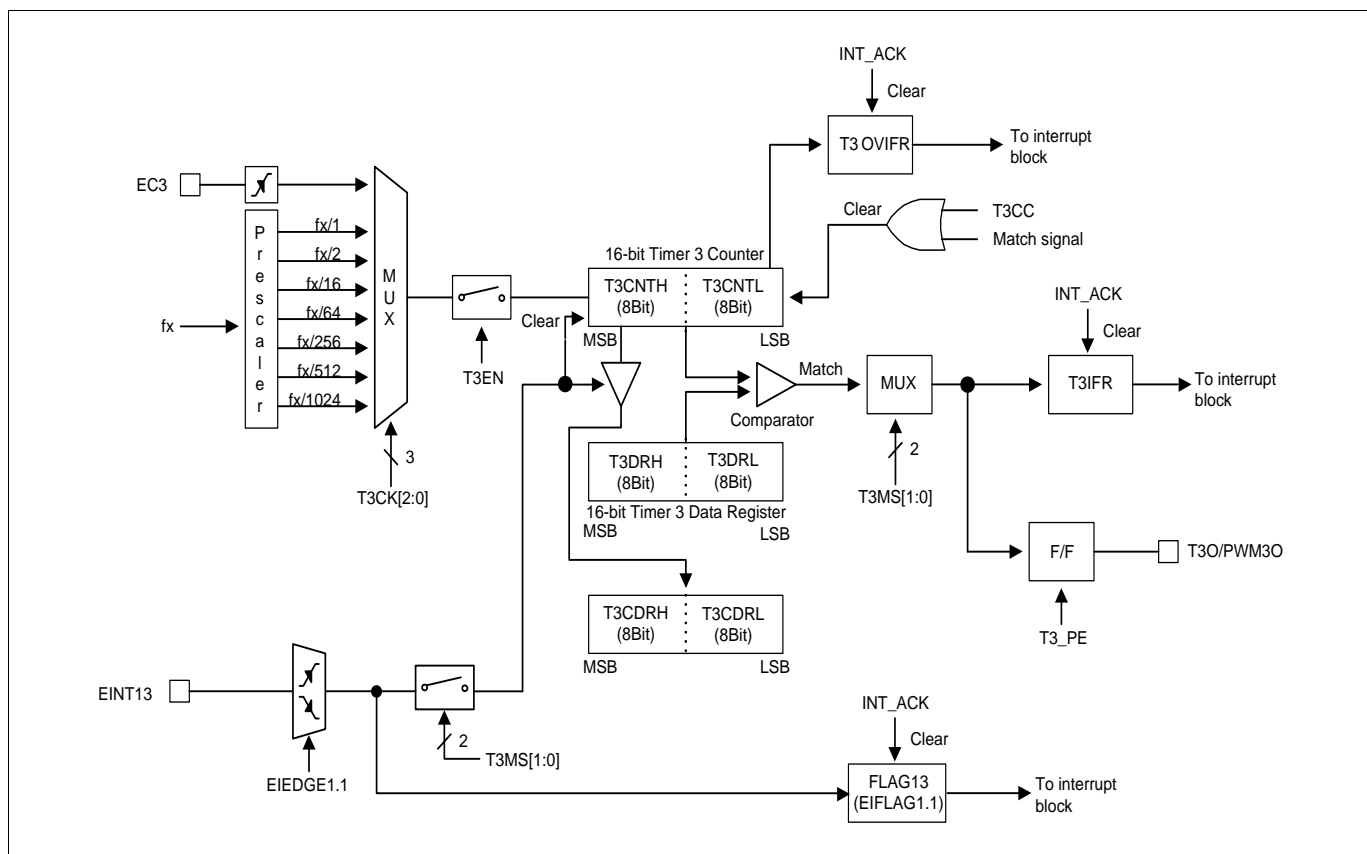

Figure 11-24. 16-Bit Timer 3 Block Diagram

11.8.6 Register Map

Name	Address	Dir	Default	Description
T3CNTH	C5H	R	00H	Timer 3 Counter High Register
T3CNTL	C4H	R	00H	Timer 3 Counter Low Register
T3DRH	C7H	R/W	FFH	Timer 3 Data High Register
T3DRL	C6H	R/W	FFH	Timer 3 Data Low Register
T3CDRH	C7H	R	00H	Timer 3 Capture Data High Register
T3CDRL	C6H	R	00H	Timer 3 Capture Data Low Register
T3CR	C2H	R/W	00H	Timer 3 Control Register
TIFR	C3H	R/W	00H	Timer Interrupt Flag Register

Table 11-11. Timer 3 Register Map

11.8.7 Timer/Counter 3 Register Description

The timer/counter 3 register consists of timer 3 counter high register (T3CNTH), timer 3 counter low register (T3CNTL), timer 3 data high register (T3DRH), timer 3 data low register (T3DRL), timer 3 capture data high register (T3CDRH), timer 3 capture data low register (T3CDRL), timer 3 control register (T3CR), and timer interrupt flag register (TIFR).

11.8.8 Register Description for Timer/Counter 3

T3CNTH (Timer 3 Counter High Register) : C5H

7	6	5	4	3	2	1	0
T3CNTH7	T3CNTH6	T3CNTH5	T3CNTH4	T3CNTH3	T3CNTH2	T3CNTH1	T3CNTH0
R	R	R	R	R	R	R	R

Initial value : 00H

T3CNTH[7:0] T3 Counter High

T3CNTL (Timer 3 Counter Low Register) : C4H

7	6	5	4	3	2	1	0
T3CNTL7	T3CNTL6	T3CNTL5	T3CNTL4	T3CNTL3	T3CNTL2	T3CNTL1	T3CNTL0
R	R	R	R	R	R	R	R

Initial value : 00H

T3CNTL[7:0] T3 Counter Low

T3DRH (Timer 3 Data High Register) : C7H

7	6	5	4	3	2	1	0
T3DRH7	T3DRH6	T3DRH5	T3DRH4	T3DRH3	T3DRH2	T3DRH1	T3DRH0
RW	RW	RW	RW	RW	RW	RW	RW

Initial value : FFH

T3DRH[7:0] T3 Data High

T3DRL (Timer 3 Data Low Register) : C6H

7	6	5	4	3	2	1	0
T3DRL7	T3DRL6	T3DRL5	T3DRL4	T3DRL3	T3DRL2	T3DRL1	T3DRL0
RW	RW	RW	RW	RW	RW	RW	RW

Initial value : FFH

T3DRL[7:0] T3 Data Low

T3CDRH (Timer 3 Capture Data High Register: Read Case, 16-bit Capture mode only) : C7H

7	6	5	4	3	2	1	0
T3CDRH7	T3CDRH6	T3CDRH5	T3CDRH4	T3CDRH3	T3CDRH2	T3CDRH1	T3CDRH0
R	R	R	R	R	R	R	R

Initial value : 00H

T3CDRH[7:0] T3 Capture Data High

T3CDRL (Timer 3 Capture Data Low Register: Read Case, 16-bit Capture mode only) : C6H

7	6	5	4	3	2	1	0
T3CDRL7	T3CDRL6	T3CDRL5	T3CDRL4	T3CDRL3	T3CDRL2	T3CDRL1	T3CDRL0
R	R	R	R	R	R	R	R

Initial value : 00H

T3CDRL[7:0] T3 Capture Data Low

T3CR (Timer 3 Control Register) : C2H

7	6	5	4	3	2	1	0
T3EN	T3_PE	T3MS1	T3MS0	T3CK2	T3CK1	T3CK0	T3CC
RW	RW	RW	RW	RW	RW	RW	RW

Initial value : 00H

- T3EN** Control Timer 3
 - 0 Timer 3 disable
 - 1 Timer 3 enable
- T3_PE** Control T3O/PWM3O Output port
 - 0 T3O/PWM3O Output disable
 - 1 T3O/PWM3O Output enable
- T3MS[1:0]** Control Timer 3 Operation Mode

T3MS1	T3MS0	Description
0	0	Timer/counter mode
0	1	PWM mode
1	x	Capture mode
- T3CK[2:0]** Select Timer 3 clock source. fx is main system clock frequency

T3CK2	T3CK1	T3CK0	Description
0	0	0	fx/1
0	0	1	fx/2
0	1	0	fx/16
0	1	1	fx/64
1	0	0	fx/256
1	0	1	fx/512
1	1	0	fx/1024
1	1	1	External Clock (EC3)
- T3CC** Clear Timer 3 Counter
 - 0 No effect
 - 1 Clear the Timer 3 counter (When write, automatically cleared "0" after being cleared counter)

NOTE)

1. Match Interrupt is generated in Capture mode.

TIFR (Timer Interrupt Flag Register) : C3H

7	6	5	4	3	2	1	0
SIOIFR	–	T3OVIFR	T0OVIFR	T3IFR	T2IFR	T1IFR	T0IFR
RW	–	RW	RW	RW	RW	RW	RW

Initial value : 00H

- SIOIFR** When SIO interrupt occurs, this bit becomes '1'. For clearing bit, write '0' to this bit or auto clear by INT_ACK signal. Writing '1' has no effect.
- 0 SIO Interrupt no generation
1 SIO Interrupt generation
- T3OVIFR** When T3 Overflow interrupt occurs, this bit becomes '1'. For clearing bit, write '0' to this bit or auto clear by INT_ACK signal. Writing '1' has no effect.
- 0 T3 Overflow Interrupt no generation
1 T3 Overflow Interrupt generation
- T0OVIFR** When T0 Overflow interrupt occurs, this bit becomes '1'. For clearing bit, write '0' to this bit or auto clear by INT_ACK signal. Writing '1' has no effect.
- 0 T0 Overflow Interrupt no generation
1 T0 Overflow Interrupt generation
- T3IFR** When T3 interrupt occurs, this bit becomes '1'. For clearing bit, write '0' to this bit or auto clear by INT_ACK signal. Writing '1' has no effect.
- 0 T3 Interrupt no generation
1 T3 Interrupt generation
- T2IFR** When T2 interrupt occurs, this bit becomes '1'. For clearing bit, write '0' to this bit or auto clear by INT_ACK signal. Writing '1' has no effect.
- 0 T2 Interrupt no generation
1 T2 Interrupt generation
- T1IFR** When T1 interrupt occurs, this bit becomes '1'. For clearing bit, write '0' to this bit or auto clear by INT_ACK signal. Writing '1' has no effect.
- 0 T1 Interrupt no generation
1 T1 Interrupt generation
- T0IFR** When T0 interrupt occurs, this bit becomes '1'. For clearing bit, write '0' to this bit or auto clear by INT_ACK signal. Writing '1' has no effect.
- 0 T0 Interrupt no generation
1 T0 Interrupt generation

11.9 Buzzer Driver

11.9.1 Overview

The Buzzer consists of 8 bit counter, buzzer data register (BUZDR), and buzzer control register (BUZCR). The Square Wave (61.035Hz~125.0 kHz @8MHz) is outputted through P05/EINT5/EC3/BUZO pin. The buzzer data register (BUZDR) controls the buzzer frequency (look at the following expression). In buzzer control register (BUZCR), BUCK[1:0] selects source clock divided by prescaler.

$$f_{\text{BUZ}}(\text{Hz}) = \frac{\text{Oscillator Frequency}}{2 \times \text{PrescalerRatio} \times (\text{BUZDR} + 1)}$$

BUZDR[7:0]	Buzzer Frequency (kHz)			
	BUZCR[2:1]=00	BUZCR[2:1]=01	BUZCR[2:1]=10	BUZCR[2:1]=11
0000_0000	125kHz	62.5kHz	31.25kHz	15.625kHz
0000_0001	62.5kHz	31.25kHz	15.625kHz	7.812kHz
...
1111_1101	492.126Hz	246.063Hz	123.031Hz	61.515Hz
1111_1110	490.196Hz	245.098Hz	122.549Hz	61.274Hz
1111_1111	488.281Hz	244.141Hz	122.07Hz	61.035Hz

Table 11-12. Buzzer Frequency at 8MHz

11.9.2 Block Diagram

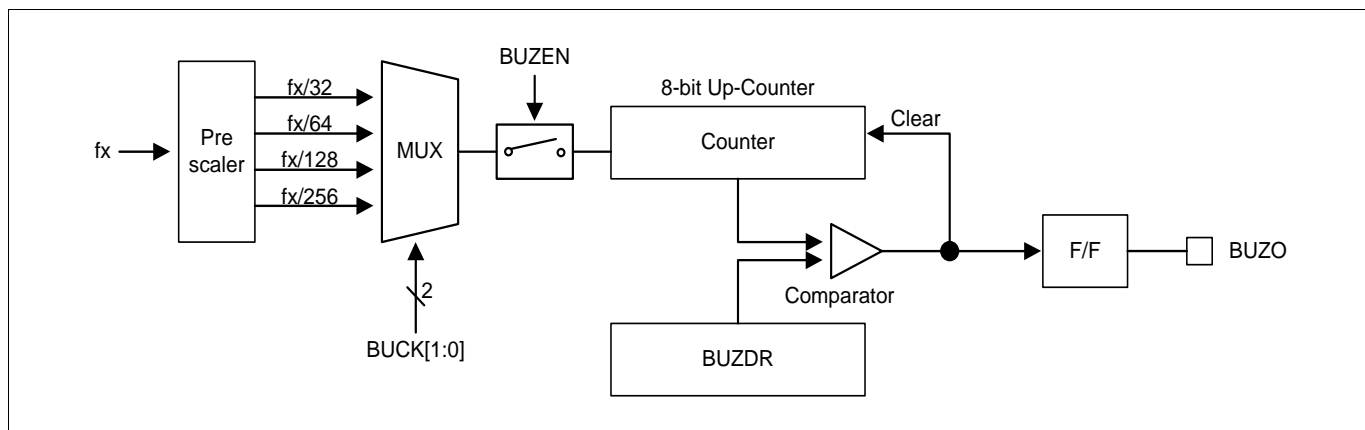

Figure 11-25. Buzzer Driver Block Diagram

11.9.3 Register Map

Name	Address	Dir	Default	Description
BUZDR	8FH	R/W	FFH	Buzzer Data Register
BUZCR	96H	R/W	00H	Buzzer Control Register

Table 11-13. Buzzer Driver Register Map

11.9.4 Buzzer Driver Register Description

Buzzer driver consists of buzzer data register (BUZDR), buzzer control register (BUZCR).

11.9.5 Register Description for Buzzer Driver

BUZDR (Buzzer Data Register) : 8FH

7	6	5	4	3	2	1	0
BUZDR7	BUZDR6	BUZDR5	BUZDR4	BUZDR3	BUZDR2	BUZDR1	BUZDR0
RW	RW	RW	RW	RW	RW	RW	RW

Initial value : FFH

BUZDR[7:0] This bits control the Buzzer frequency
Its resolution is 00H ~ FFH

BUZCR (Buzzer Control Register) : 97H

7	6	5	4	3	2	1	0
–	–	–	–	–	BUCK1	BUCK0	BUZEN
–	–	–	–	–	RW	RW	RW

Initial value : 00H

BUCK[1:0] Buzzer Driver Source Clock Selection

BUCK1 BUCK0 Description

0 0 fx/32

0 1 fx/64

1 0 fx/128

1 1 fx/256

BUZEN Buzzer Driver Operation Control

0 Buzzer Driver disable

1 Buzzer Driver enable

NOTE)

1. fx: System clock oscillation frequency.

11.10 SIO

11.10.1 Overview

The serial input/output is used to transmit/receive 8-bit data serially. The serial input/output(SIO) module is a useful serial interface to communicate with other peripheral of microcontroller devices. This SIO is 8-bit clock synchronous type and consists of SIO pre-scaler register, SIO data register, SIO control register, and control circuit as illustrated in Figure 11.26. The SO pin is designed to input and output. So SIO can operate with two pins minimally. Pin P14/SO, P15/SCK and P16/SI pins are controlled by the SIO control register (SIOCR) and port function selection control registers (PFSR05, PFSR0[7:6], and PFSR10).

The contents of the SIO data register can be written into or read out by software. The data in the SIO data register can be shifted synchronously with the transfer clock signal. SIO data register (SIODR) is an 8 bit shift register. MSB-first and LSB-first transfers are possible.

11.10.2 Block Diagram

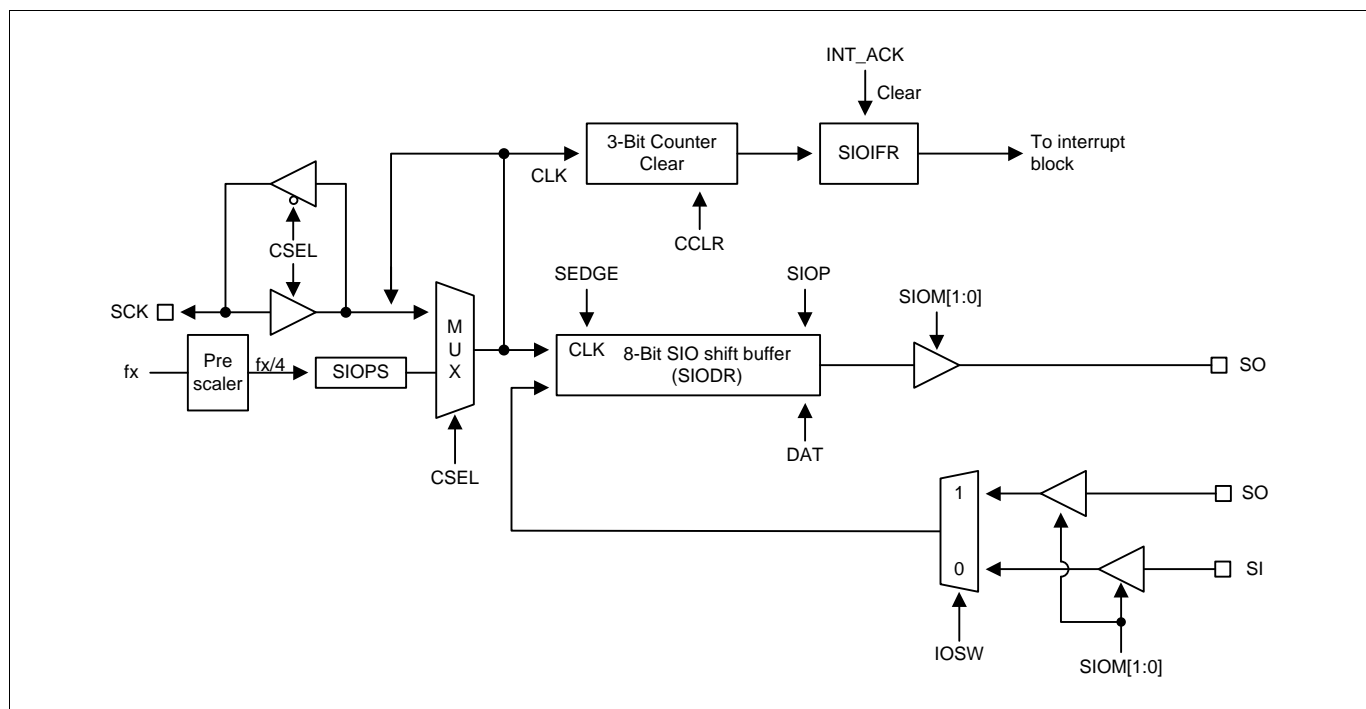

Figure 11-26. SIO Block Diagram

NOTE)

1. The system clock should be greater than the SIO input clock. So, take care of using the external clock.

11.10.3 SIO Pre-Scale Register (SIOPS)

SIOPS contains the SIO pre-scaler value. The SIO clock rate (baud rate) is calculated by the following formula.

$$\text{Baud rate} = \text{Input clock (fx/4)} / (\text{Pre-scaler value} + 1)$$

or SCK input clock, where the input clock is fx/4

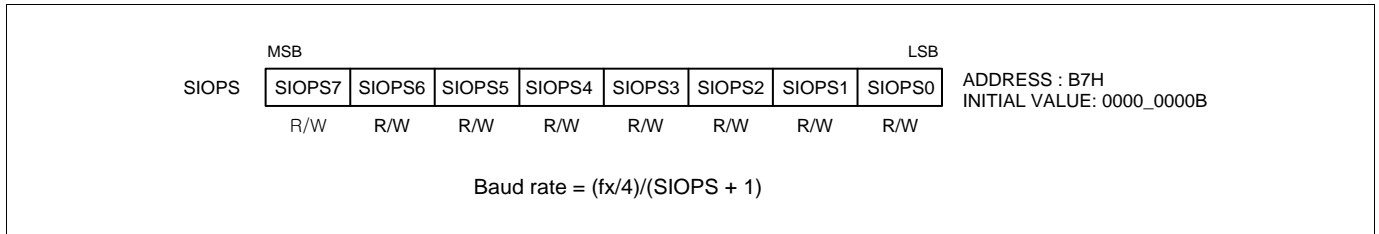

Figure 11-27. SIO Pre-Scale Register (SIOPS)

11.10.4 The usage of SIO

1. Select transmitter/receiver mode.
2. In transmitter mode, write data to be sent to SIODR.
3. Set CCLR to "1" to clear SIO counter and start shifting.
4. If Tx or Rx is completed, the SIO interrupt is generated and SIOIFR is set to "1".
5. In receiver mode, the received data can be acquired by reading SIODR.

11.10.5 SIO Timing Diagram

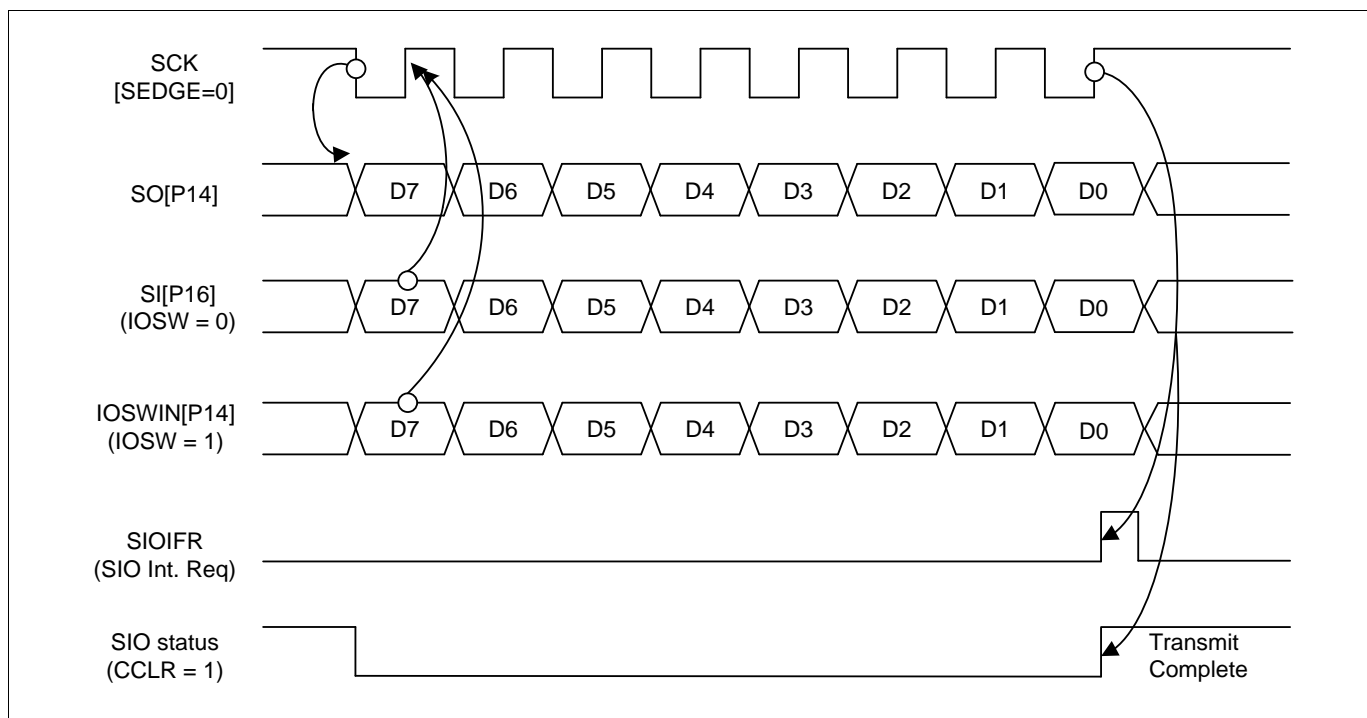

Figure 11-28. SIO Timing Diagram at SEDGE=0

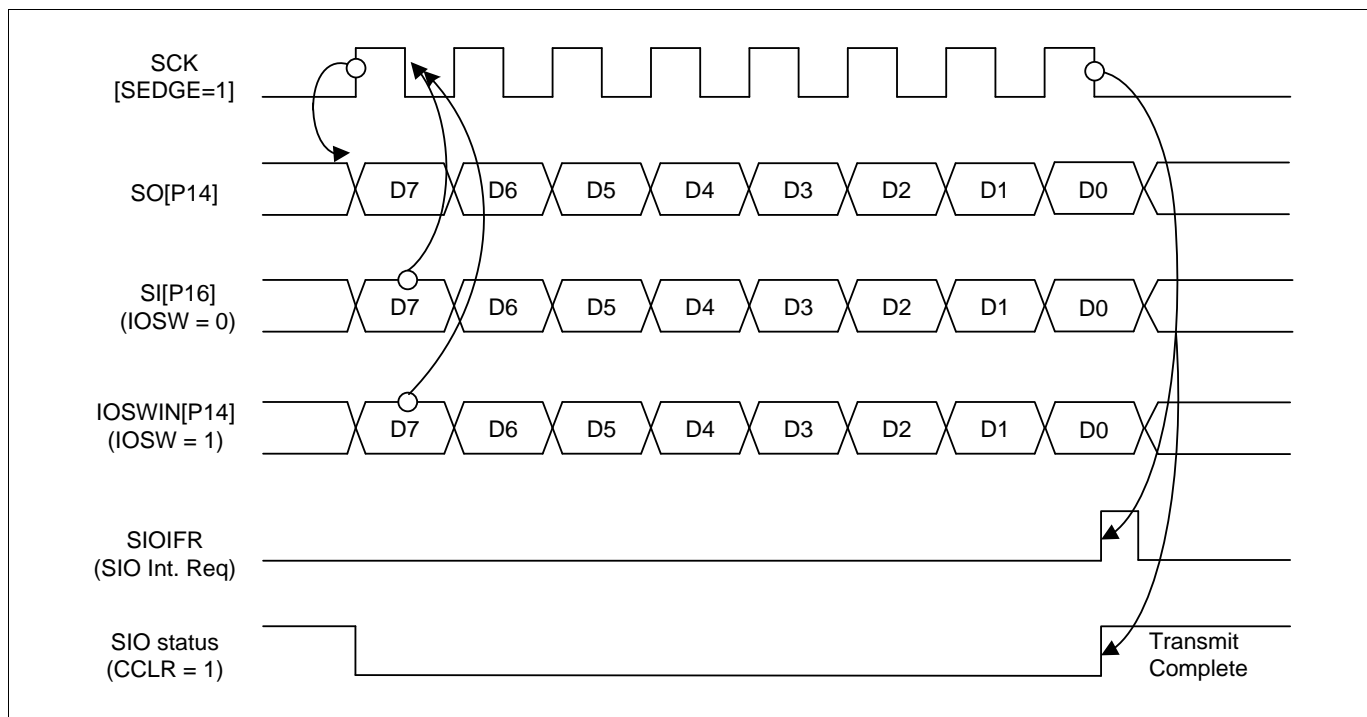

Figure 11-29. SIO Timing Diagram at SEDGE=1

11.10.6 Register Map

Name	Address	Dir	Default	Description
SIOPS	B7H	R/W	00H	SIO Pre-scale Register
SIODR	B6H	R/W	00H	SPI Data Register
SIOCR	B5H	R/W	00H	SIO Control Register

Table 11-14. SIO Register Map

11.10.7 SIO Register Description

The SIO register consists of SIO pre-scaler register (SIOPS), SIO Data Register (SIODR), and SIO control register (SIOCR). The SIOIFR bit is in the timer interrupt flag register (TIFR).

11.10.8 Register Description for SIO

SIOPS (SIO Pre-scale Register) : B7H

7	6	5	4	3	2	1	0
SIOPS7	SIOPS6	SIOPS5	SIOPS4	SIOPS3	SIOPS2	SIOPS1	SIOPS0
RW	RW	RW	RW	RW	RW	RW	RW

Initial value : 00H

SIOPS [7:0] SIO Pre-scale
 Baud Rate = $(fx/4)/(SIOPS+1)$

SIODR (SIO Data Register) : B6H

7	6	5	4	3	2	1	0
SIODR7	SIODR6	SIODR5	SIODR4	SIODR3	SIODR2	SIODR1	SIODR0
RW	RW	RW	RW	RW	RW	RW	RW

Initial value : 00H

SIODR [7:0] SIO Data

SIOCR (SIO Control Register) : B5H

7	6	5	4	3	2	1	0
CSEL	DAT	SIOP	IOSW	SIOM1	SIOM0	CCLR	SEdge
RW	RW	RW	RW	RW	RW	RW	RW

Initial value : 00H

- CSEL** SIO Shift Clock Selection
 - 0 Internal clock (P.S clock)
 - 1 External clock (SCK)
- DAT** Data Direction Control
 - 0 MSB first mode
 - 1 LSB first mode
- SIOP** SIO Shift Operation Enable
 - 0 Disable shifter and clock counter
 - 1 Enable shifter and clock counter
- IOSW** Serial Input Pin Selection Bit
 - 0 SI pin selection
 - 1 SO pin selection

NOTE)

1. If SO pin is selected for a serial data input, SO pin should be set to an input and port. So, the SIOM, PFSR05, and P14IO bits should be set to '01b', '0b' and '0b' respectively. Refer to the P1IO and PFSR0 register for setting

- SIOM[1:0]** SIO Mode Selection

SIOM1	SIOM0	Description
0	0	Transmit mode
0	1	Receive mode
1	x	Transmit/Receive mode
- CCLR** SIO Counter Clear and Shift Start
 - 0 No action
 - 1 Clear 3-bit counter and start shifting
- SEdge** SIO Clock Edge Selection
 - 0 Tx at falling edges, Rx at rising edges
 - 1 Tx at rising edge, Rx at falling edges

NOTE)

1. The serial I/O interrupt flag (SIOIFR bit) is in the timer interrupt flag register (TIFR register).

11.11 12-Bit A/D Converter

11.11.1 Overview

The analog-to-digital converter (A/D) allows conversion of an analog input signal to corresponding 12-bit digital value. The A/D module has five analog inputs. The output of the multiplexer is the input into the converter which generates the result through successive approximation. The A/D module has four registers which are the A/D converter control high register (ADCCRH), A/D converter control low register (ADCCRL), A/D converter data high register (ADCDRH), and A/D converter data low register (ADCDRL). The channels to be converted are selected by setting ADSEL[3:0]. To execute A/D conversion, ADST bit should be set to '1'. The register ADCDRH and ADCDRL contains the results of the A/D conversion. When the conversion is completed, the result is loaded into the ADCDRH and ADCDRL, the A/D conversion status bit AFLAG is set to '1', and the A/D interrupt is set. During A/D conversion, AFLAG bit is read as '0'.

11.11.2 Conversion Timing

The A/D conversion process requires 4steps (4clock edges) to convert each bit and 10clocks to set up A/D conversion. Therefore, total of 58 clocks are required to complete a 12-bit conversion: When fxx/8 is selected for conversion clock with a 12MHz fxx clock frequency, one clock cycle is 0.66us. Each bit conversion requires 4clocks, the conversion rate is calculated as follows:

$$4\text{clocks/bit} \times 12\text{bits} + \text{set-up time} = 58\text{clocks},$$

$$58\text{clock} \times 0.66\text{us} = 38.28\text{us at } 1.5\text{MHz (12MHz/8)}$$

NOTE)

1. The A/D converter needs at least 20us for conversion time. So you must set the conversion time more than 20us.

11.11.3 Block Diagram

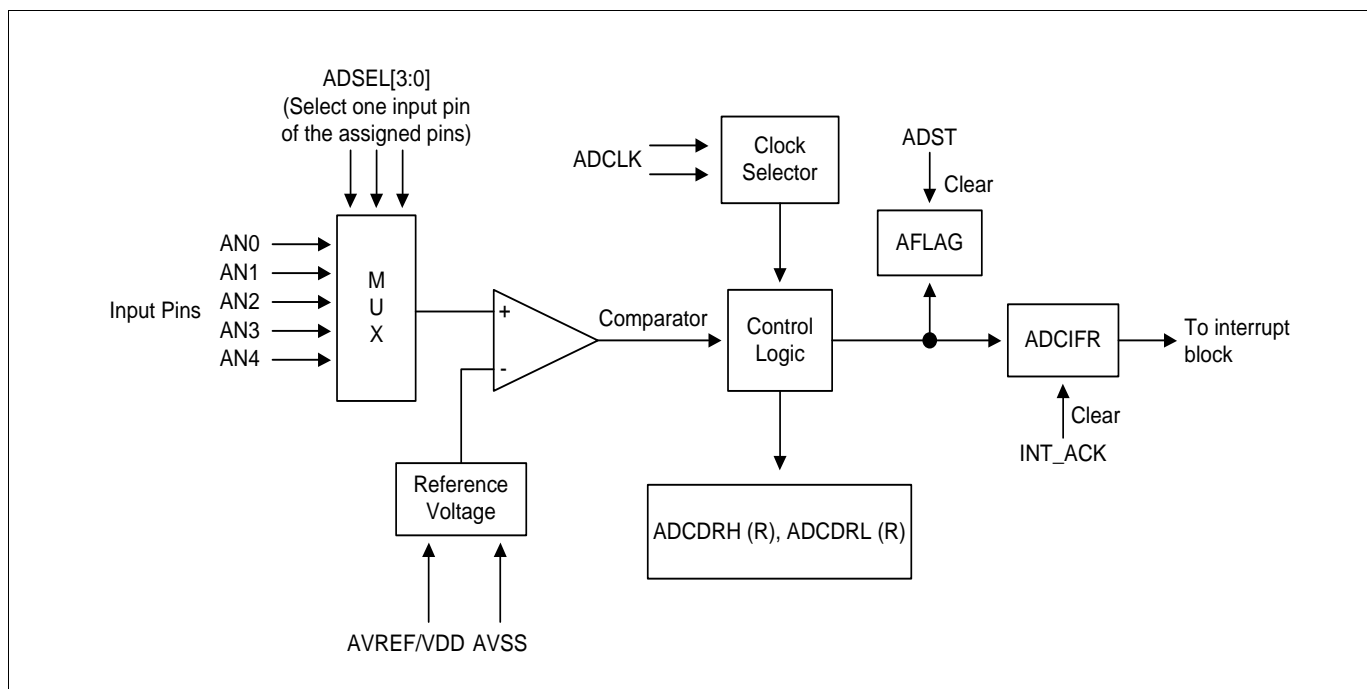

Figure 11-30. 12-bit ADC Block Diagram

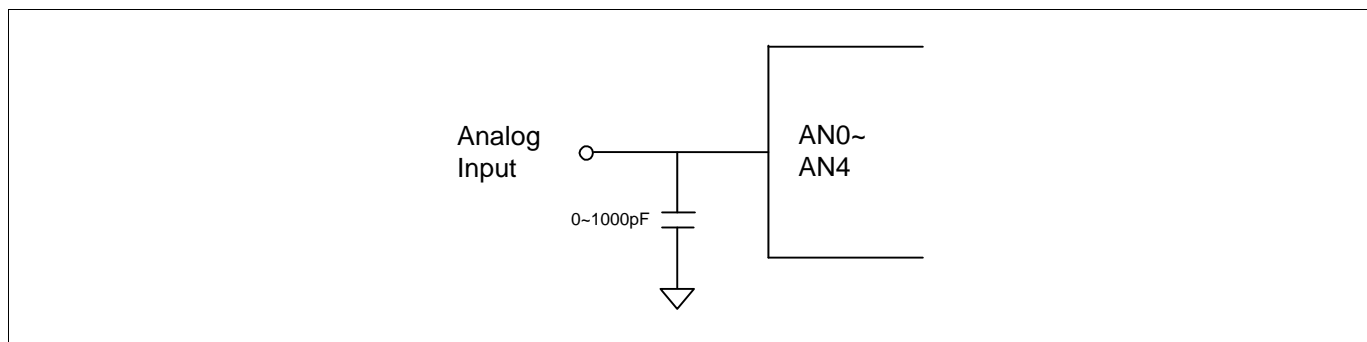

Figure 11-31. A/D Analog Input Pin with Capacitor

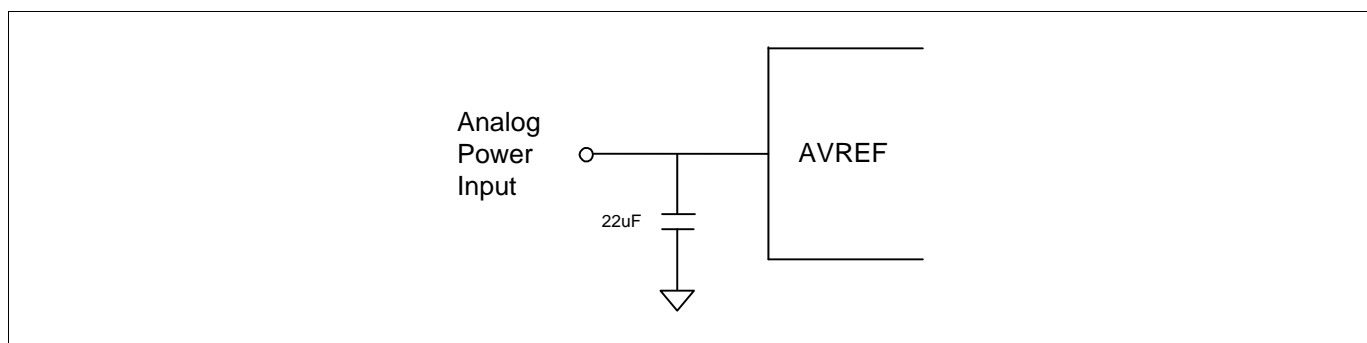

Figure 11-32. A/D Power (AVDD) Pin with Capacitor

11.11.4 ADC Operation

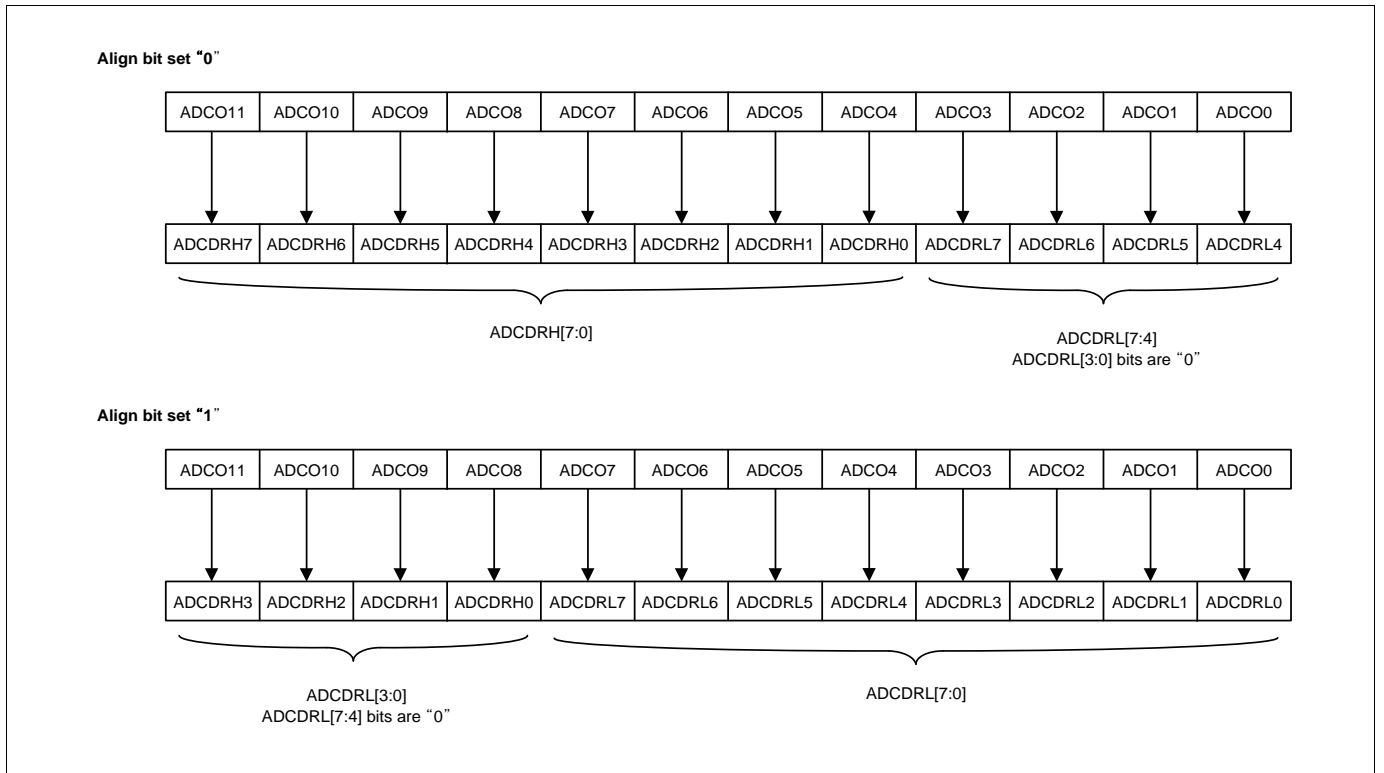

Figure 11-33. ADC Operation for Align Bit

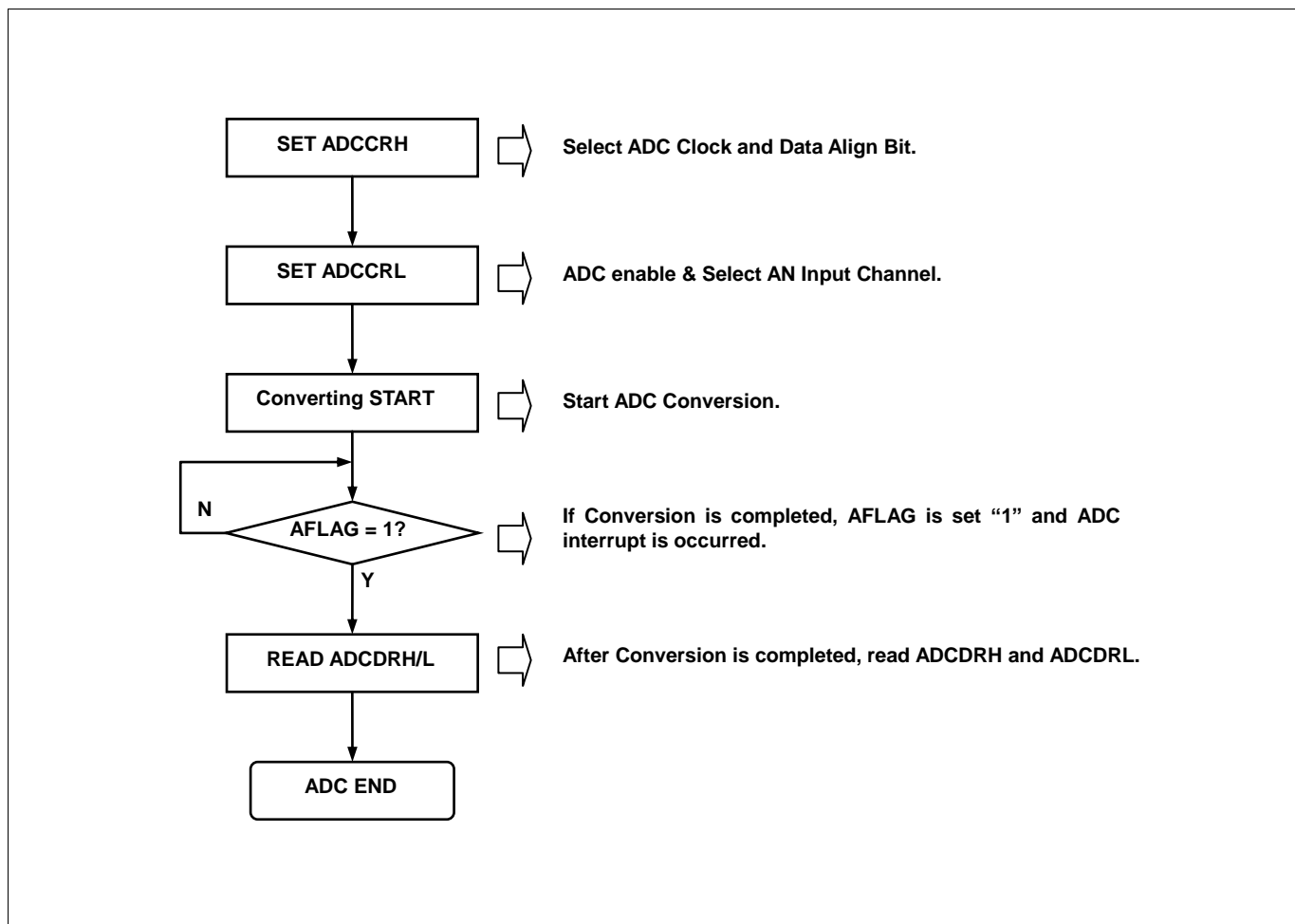

Figure 11-34. A/D Converter Operation Flow

11.11.5 Register Map

Name	Address	Dir	Default	Description
ADCDRH	9CH	R	xxH	A/D Converter Data High Register
ADCDRL	9BH	R	xxH	A/D Converter Data Low Register
ADCCRH	9DH	R/W	00H	A/D Converter Control High Register
ADCCRL	9AH	R/W	00H	A/D Converter Control Low Register

Table 11-15. ADC Register Map

11.11.6 ADC Register Description

The ADC register consists of A/D converter data high register (ADCDRH), A/D converter data low register (ADCDRL), A/D converter control high register (ADCCRH), and A/D converter control low register (ADCCRL).

11.11.7 Register Description for ADC

ADCDRH (A/D Converter Data High Register) : 9CH

7	6	5	4	3	2	1	0
ADDM11	ADDM10	ADDM9	ADDM8	ADDM7 ADDL11	ADDM6 ADDL10	ADDM5 ADDL9	ADDM4 ADDL8
R	R	R	R	R	R	R	R

Initial value : xxH

ADDM[11:4] MSB align, A/D Converter High Data (8-bit)**ADDL[11:8]** LSB align, A/D Converter High Data (4-bit)

ADCDRL (A/D Converter Data Low Register) : 9BH

7	6	5	4	3	2	1	0
ADDM3 ADDL7	ADDM2 ADDL6	ADDM1 ADDL5	ADDM0 ADDL4	ADDL3	ADDL2	ADDL1	ADDL0
R	R	R	R	R-	R	R	R

Initial value : xxH

ADDM[3:0] MSB align, A/D Converter Low Data (4-bit)**ADDL[7:0]** LSB align, A/D Converter Low Data (8-bit)

ADCCRH (A/D Converter High Register) : 9DH

7	6	5	4	3	2	1	0
ADCIFR	-	-	-	-	ALIGN	CKSEL1	CKSEL0
RW	-	-	-	-	RW	RW	RW

Initial value : 00H

ADCIFR When ADC interrupt occurs, this bit becomes '1'. For clearing bit, write '0' to this bit or auto clear by INT_ACK signal. Writing "1" has no effect.

- 0 ADC Interrupt no generation
- 1 ADC Interrupt generation

ALIGN A/D Converter data align selection.

- 0 MSB align (ADCDRH[7:0], ADCDRL[7:4])
- 1 LSB align (ADCDRH[3:0], ADCDRL[7:0])

CKSEL[1:0] A/D Converter Clock selection

CKSEL1	CKSEL0	Description
0	0	fx/1
0	1	fx/2
1	0	fx/4
1	1	fx/8

ADCCRL (A/D Converter Counter Low Register) : 9AH

7	6	5	4	3	2	1	0
STBY	ADST	REFSEL	AFLAG	ADSEL3	ADSEL2	ADSEL1	ADSEL0
RW	RW	RW	R	RW	RW	RW	RW

Initial value : 00H

- STBY** Control Operation of A/D
(The ADC module is automatically disabled at stop mode)
0 ADC module disable
1 ADC module enable
- ADST** Control A/D Conversion stop/start.
0 No effect
1 ADC Conversion Start and auto clear
- REFSEL** A/D Converter Reference Selection
0 Internal Reference (VDD)
1 External Reference (AVREF)
- AFLAG** A/D Converter Operation State (This bit is cleared to '0' when the STBY bit is set to '0' or when the CPU is at STOP mode)
0 During A/D Conversion
1 A/D Conversion finished
- ADSEL[3:0]** A/D Converter input selection

ADSEL3	ADSEL2	ADSEL1	ADSEL0	Description
0	0	0	0	AN0
0	0	0	1	AN1
0	0	1	0	AN2
0	0	1	1	AN3
0	1	0	0	AN4

Other values: Not available

11.12 UART

11.12.1 Overview

The universal synchronous and asynchronous serial receiver and transmitter (UART) is a highly flexible serial communication device. The main features are listed below.

- Full Duplex Operation (Independent Serial Receive and Transmit Registers)
- Asynchronous or Synchronous Operation
- Baud Rate Generator
- Supports Serial Frames with 5,6,7,8, or 9 Data Bits and 1 or 2 Stop Bits
- Odd or Even Parity Generation and Parity Check Supported by Hardware
- Data OverRun Detection
- Framing Error Detection
- Three Separate Interrupts on TX Complete, TX Data Register Empty and RX Complete

UART has two main parts of clock generator, transmitter and receiver. The clock generation logic consists of synchronization logic for external clock input used by synchronous operation, and the baud rate generator for asynchronous or master synchronous operation. The Transmitter consists of a single write buffer, a serial shift register, parity generator and control logic for handling different serial frame formats. The write buffer allows continuous transfer of data without any delay between frames. The receiver is the most complex part of the UART module due to its clock and data recovery units. The recovery unit is used for asynchronous data reception. In addition to the recovery unit, the receiver includes a parity checker, a shift register, a two-level receive FIFO (UARTDR) and control logic. The receiver supports the same frame formats as the transmitter and can detect frame error, data overrun and parity errors.

11.12.2 Block Diagram

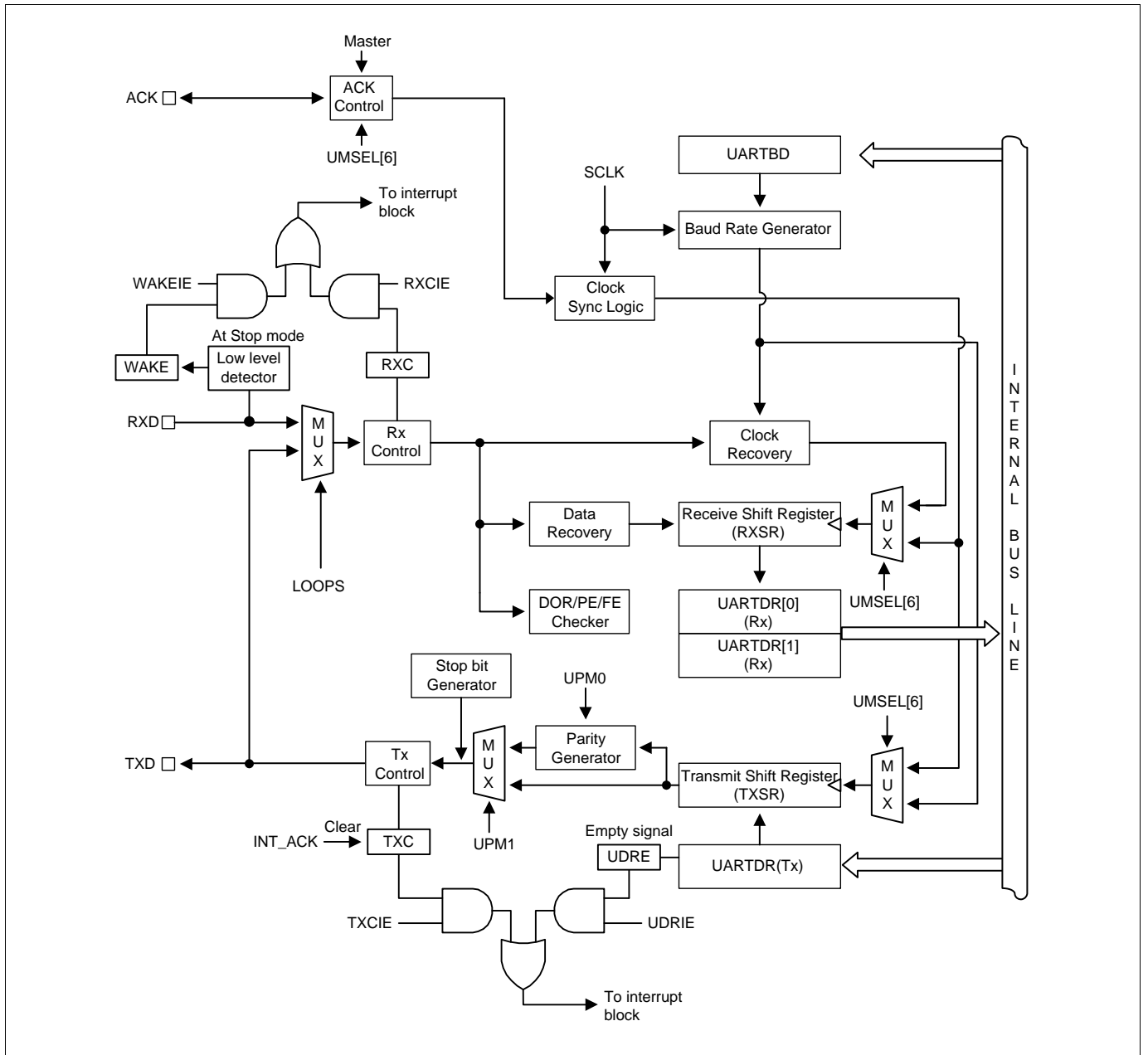

Figure 11-35. UART Block Diagram

11.12.3 Clock Generation

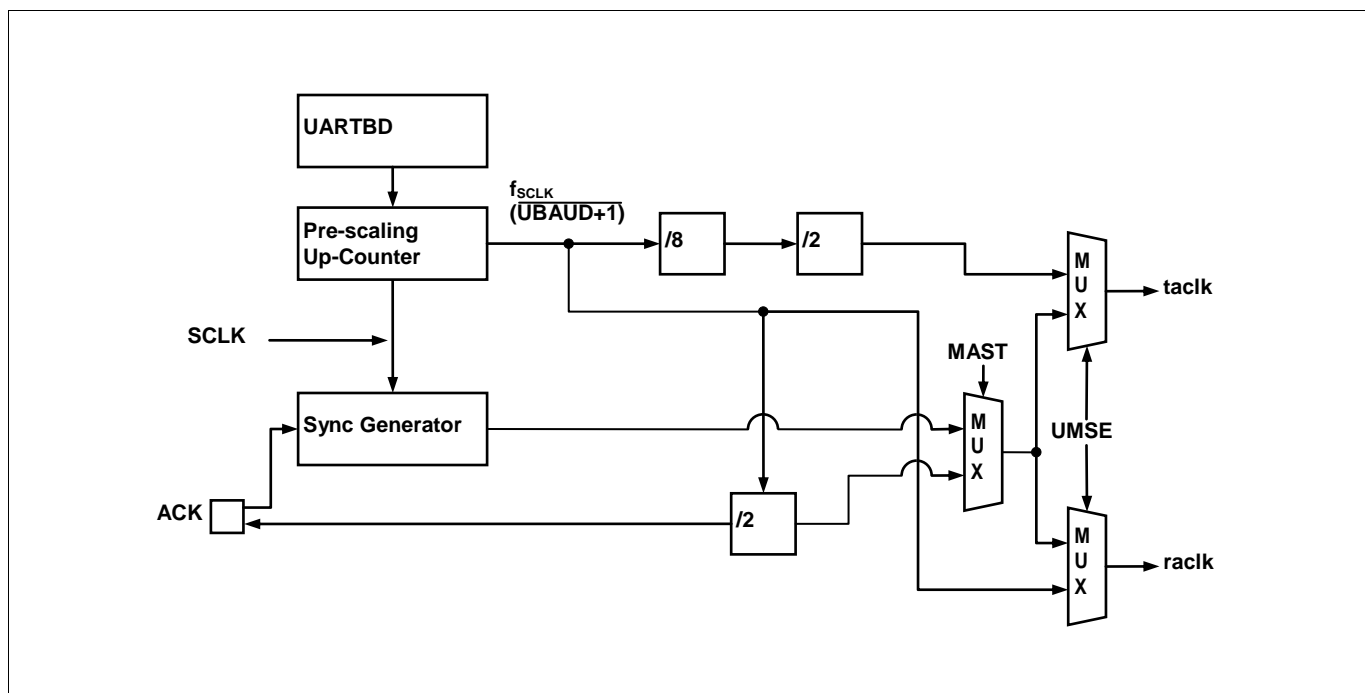

Figure 11-36. Clock Generation Block Diagram

The clock generation logic generates the base clock for the transmitter and receiver. The UART supports three modes of clock operation and those are asynchronous, master synchronous and slave synchronous mode. The UMSEL bit in UARTCR1 register selects asynchronous or synchronous operation. The MASTER bit in UARTCR3 register controls whether the clock source is internal (master mode, output pin) or external (slave mode, input pin). The ACK pin is active only when the UART operates in synchronous mode.

Following table shows the equations for calculating the baud rate (in bps).

Operating Mode	Equation for Calculating Baud Rate
Asynchronous Normal Mode	$\text{Baud Rate} = \frac{f_x}{16(\text{UARTBD} + 1)}$
Synchronous Master Mode	$\text{Baud Rate} = \frac{f_x}{2(\text{UARTBD} + 1)}$

Table 11-16. Equations for Calculating Baud Rate Register Setting

11.12.4 External Clock (ACK)

External clocking is used in the synchronous mode of operation.

External clock input from the ACK pin is sampled by a synchronization logic to remove meta-stability. The output from the synchronization logic must be passed through an edge detector before it is used by the transmitter and receiver. This process introduces two CPU clock period delay. The maximum frequency of the external ACK pin is limited up-to 1MHz.

11.12.5 Synchronous mode operation

When synchronous mode is used, the ACK pin will be used as either clock input (slave) or clock output (master). Data sampling and transmitter is issued on the different edge of ACK clock each other. For example, if data input on RXD pin is sampled on the rising edge of ACK clock, data output on TXD pin is altered on the falling edge.

The UCPOL bit in UARTCR1 register selects which ACK clock edge is used for data sampling and which is used for data change. As shown in the figure below, when UCPOL is zero, the data will be changed at rising ACK edge and sampled at falling ACK edge.

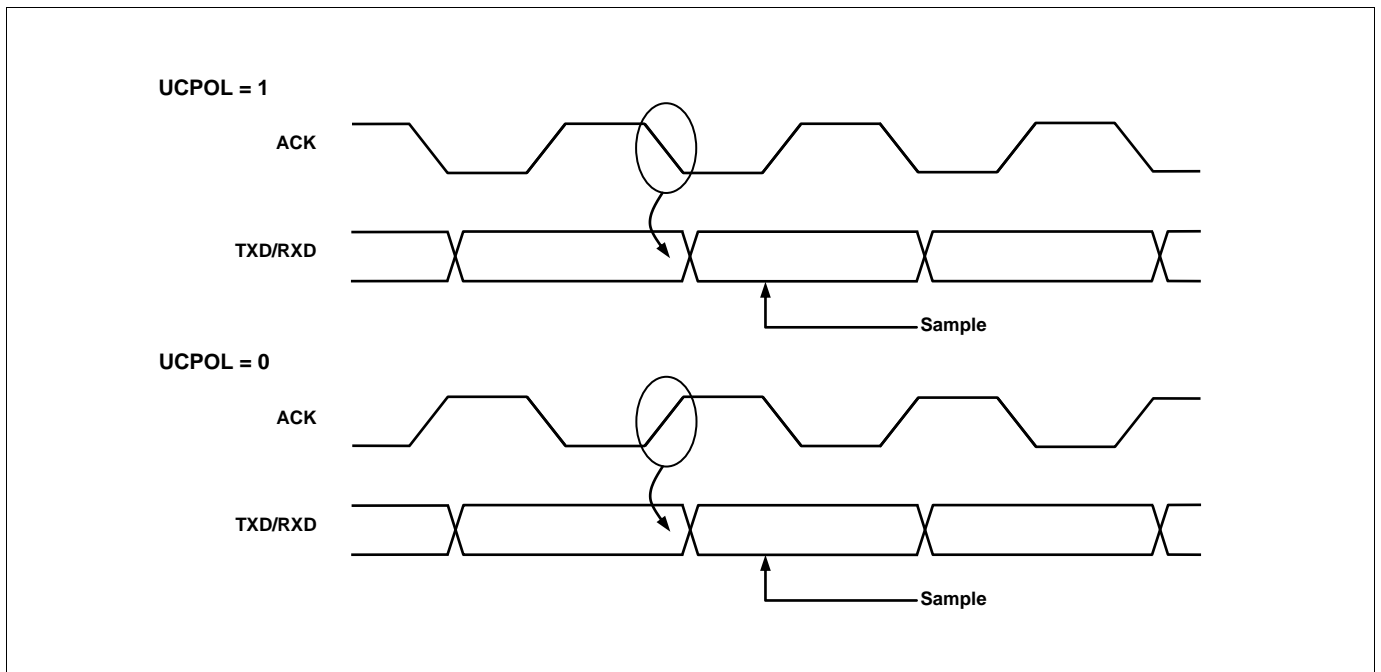

Figure 11-37. Synchronous Mode ACK Timing

11.12.6 Data format

A serial frame is defined to be one character of data bits with synchronization bits (start and stop bits), and optionally a parity bit for error detection.

The UART supports all 30 combinations of the following as valid frame formats.

- 1 start bit
- 5, 6, 7, 8 or 9 data bits
- no, even or odd parity bit
- 1 or 2 stop bits

A frame starts with the start bit followed by the least significant data bit (LSB). Then the next data bits, up to nine, are succeeding, ending with the most significant bit (MSB). If parity function is enabled, the parity bit is inserted between the last data bit and the stop bit. A high-to-low transition on data pin is considered as start bit. When a complete frame is transmitted, it can be directly followed by a new frame, or the communication line can be set to an idle state. The idle means high state of data pin. The following figure shows the possible combinations of the frame formats. Bits inside brackets are optional.

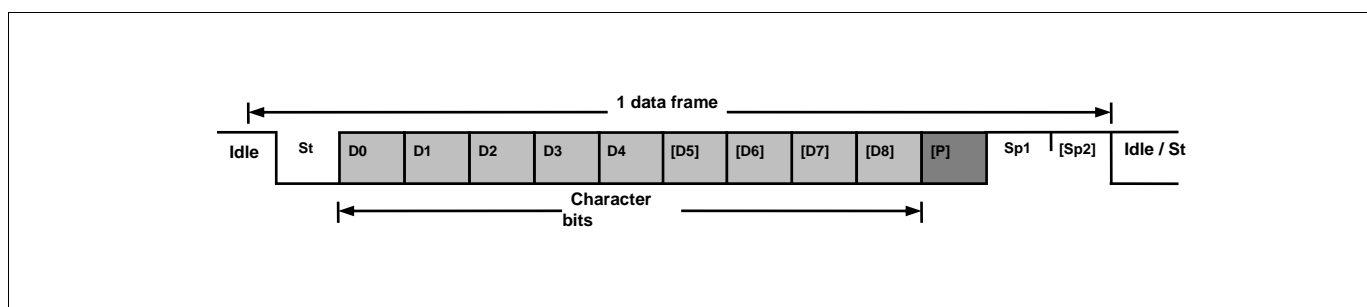

Figure 11-38. Frame Format

1 data frame consists of the following bits

- Idle No communication on communication line (TxD/RxD)
- St Start bit (Low)
- Dn Data bits (0~8)
- Parity bit ----- Even parity, Odd parity, No parity
- Stop bit(s) ----- 1 bit or 2 bits

The frame format used by the UART is set by the USIZE[2:0], UPM[1:0] and USBS bits in UARTCR1 and UARTCR3 register. The Transmitter and Receiver use the same setting.

11.12.7 Parity bit

The parity bit is calculated by doing an exclusive-OR of all the data bits. If odd parity is used, the result of the exclusive-O is inverted. The parity bit is located between the MSB and first stop bit of a serial frame.

$$P_{\text{even}} = D_{n-1} \wedge \dots \wedge D_3 \wedge D_2 \wedge D_1 \wedge D_0 \wedge 0$$

$$P_{\text{odd}} = D_{n-1} \wedge \dots \wedge D_3 \wedge D_2 \wedge D_1 \wedge D_0 \wedge 1$$

P_{even} : Parity bit using even parity

P_{odd} : Parity bit using odd parity

D_n : Data bit n of the character

11.12.8 UART Transmitter

The UART transmitter is enabled by setting the TXE bit in UARTCR2 register. When the Transmitter is enabled, the TXD pin should be set to TXD function for the serial output pin of UART by the PFSR8[5:4]. The baud-rate, operation mode and frame format must be setup once before doing any transmission. In synchronous operation mode, the ACK pin is used as transmission clock, so it should be selected to do ACK function by PFSR8[3:2].

11.12.8.1 Sending Tx data

A data transmission is initiated by loading the transmit buffer (UARTDR register I/O location) with the data to be transmitted. The data written in transmit buffer is moved to the shift register when the shift register is ready to send a new frame. The shift register is loaded with the new data if it is in idle state or immediately after the last stop bit of the previous frame is transmitted. When the shift register is loaded with new data, it will transfer one complete frame according to the settings of control registers. If the 9-bit characters are used in asynchronous or synchronous operation mode, the ninth bit must be written to the TX8 bit in UARTCR3 register before it is loaded to the transmit buffer (UARTDR register).

11.12.8.2 Transmitter flag and interrupt

The UART transmitter has 2 flags which indicate its state. One is UART data register empty flag (UDRE) and the other is transmit complete flag (TXC). Both flags can be interrupt sources.

UDRE flag indicates whether the transmit buffer is ready to receive new data. This bit is set when the transmit buffer is empty and cleared when the transmit buffer contains data to be transmitted but has not yet been moved into the shift register. And also this flag can be cleared by writing '0' to this bit position. Writing '1' to this bit position is prevented.

When the data register empty interrupt enable (UDRIE) bit in UARTCR2 register is set and the global interrupt is enabled, UARTST data register empty interrupt is generated while UDRE flag is set.

The transmit complete (TXC) flag bit is set when the entire frame in the transmit shift register has been shifted out and there is no more data in the transmit buffer. The TXC flag is automatically cleared when the transmit complete interrupt service routine is executed, or it can be cleared by writing '0' to TXC bit in UARTST register.

When the transmit complete interrupt enable (TXCIE) bit in UARTCR2 register is set and the global interrupt is enabled, UART transmit complete interrupt is generated while TXC flag is set.

11.12.8.3 Parity Generator

The parity generator calculates the parity bit for the serial frame data to be sent. When parity bit is enabled (UPM[1]=1), the transmitter control logic inserts the parity bit between the MSB and the first stop bit of the frame to be sent.

11.12.8.4 Disabling Transmitter

Disabling the transmitter by clearing the TXE bit will not become effective until ongoing transmission is completed. When the Transmitter is disabled, the TXD pin can be used as a normal general purpose I/O (GPIO).

11.12.9 UART Receiver

The UART receiver is enabled by setting the RXE bit in the UARTCR2 register. When the receiver is enabled, the RXD pin should be set to RXD function for the serial input pin of UART by PFSR8[7:6]. The baud-rate, mode of operation and frame format must be set before serial reception. In synchronous operation mode the ACK pin is used as transfer clock, so it should be selected to do ACK function by PFSR8[3:2].

11.12.9.1 Receiving Rx data

When UART is in synchronous or asynchronous operation mode, the receiver starts data reception when it detects a valid start bit (LOW) on RXD pin. Each bit after start bit is sampled at pre-defined baud-rate (asynchronous) or sampling edge of ACK (synchronous), and shifted into the receive shift register until the first stop bit of a frame is received. Even if there's 2nd stop bit in the frame, the 2nd stop bit is ignored by the receiver. That is, receiving the first stop bit means that a complete serial frame is present in the receiver shift register and contents of the shift register are to be moved into the receive buffer. The receive buffer is read by reading the UARTDR register.

If 9-bit characters are used (USIZE[2:0] = "111"), the ninth bit is stored in the RX8 bit position in the UARTCR3 register. The 9th bit must be read from the RX8 bit before reading the low 8 bits from the UARTDR register. Likewise, the error flags FE, DOR, PE must be read before reading the data from UARTDR register. It's because the error flags are stored in the same FIFO position of the receive buffer.

11.12.9.2 Receiver Flag and Interrupt

The UART receiver has one flag that indicates the receiver state.

The receive complete (RXC) flag indicates whether there are unread data in the receive buffer. This flag is set when there are unread data in the receive buffer and cleared when the receive buffer is empty. If the receiver is disabled (RXE=0), the receiver buffer is flushed and the RXC flag is cleared.

When the receive complete interrupt enable (RXCIE) bit in the UARTCR2 register is set and global interrupt is enabled, the UART receiver complete interrupt is generated while RXC flag is set.

The UART receiver has three error flags which are frame error (FE), data overrun (DOR) and parity error (PE). These error flags can be read from the UARTST register. As received data are stored in the 2-level receive buffer, these error flags are also stored in the same position of receive buffer. So, before reading received data from UARTDR register, read the UARTST register first which contains error flags.

The frame error (FE) flag indicates the state of the first stop bit. The FE flag is '0' when the stop bit was correctly detected as "1", and the FE flag is "1" when the stop bit was incorrect, i.e. detected as "0". This flag can be used for detecting out-of-sync conditions between data frames.

The data overrun (DOR) flag indicates data loss due to a receive buffer full condition. DOR occurs when the receive buffer is full, and another new data is present in the receive shift register which are to be stored into the receive buffer. After the DOR flag is set, all the incoming data are lost. To prevent data loss or clear this flag, read the receive buffer.

The parity error (PE) flag indicates that the frame in the receive buffer had a parity error when received. If parity check function is not enabled (UPM[1]=0), the PE bit is always read "0".

11.12.9.3 Parity Checker

If parity bit is enabled (UPM[1]=1), the Parity Checker calculates the parity of the data bits in incoming frame and compares the result with the parity bit from the received serial frame.

11.12.9.4 Disabling Receiver

In contrast to transmitter, disabling the Receiver by clearing RXE bit makes the Receiver inactive immediately. When the receiver is disabled, the receiver flushes the receive buffer, the remaining data in the buffer is all reset, and the RXD pin can be used as a normal general purpose I/O (GPIO).

11.12.9.5 Asynchronous Data Reception

To receive asynchronous data frame, the UART includes a clock and data recovery unit. The clock recovery logic is used for synchronizing the internally generated baud-rate clock to the incoming asynchronous serial frame on the RXD pin.

The data recovery logic samples and low pass filters the incoming bits, and this removes the noise of RXD pin.

The next figure illustrates the sampling process of the start bit of an incoming frame. The sampling rate is 16 times of the baud-rate in normal mode. The horizontal arrows show the synchronization variation due to the asynchronous sampling process.

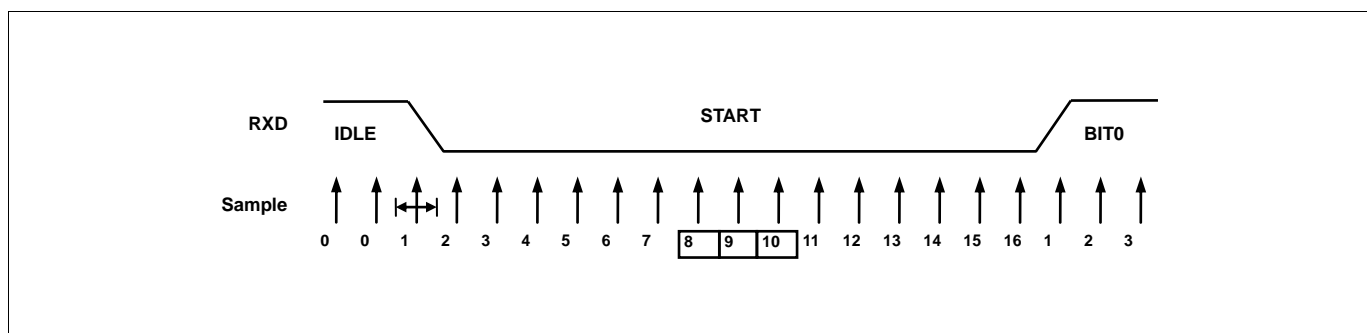

Figure 11-39. Start Bit Sampling

When the receiver is enabled (RXE=1), the clock recovery logic tries to find a high-to-low transition on the RXD line, the start bit condition. After detecting high to low transition on RXD line, the clock recovery logic uses samples 8,9, and 10 for normal mode to decide if a valid start bit is received. If more than 2 samples have logical low level, it is considered that a valid start bit is detected and the internally generated clock is synchronized to the incoming data frame. And the data recovery can begin. The synchronization process is repeated for each start bit.

As described above, when the receiver clock is synchronized to the start bit, the data recovery can begin. Data recovery process is almost similar to the clock recovery process. The data recovery logic samples 16 times for each incoming bits, and uses sample 8, 9, and 10 to decide data value. If more than 2 samples have low levels, the received bit is considered to a logic '0' and if more than 2 samples have high levels, the received bit is considered to a logic '1'. The data recovery process is then repeated until a complete frame is received including the first stop bit. The decided bit value is stored in the receive shift register in order. Note that the Receiver only uses the first stop bit of a frame. Internally, after receiving the first stop bit, the Receiver is in idle state and waiting to find start bit.

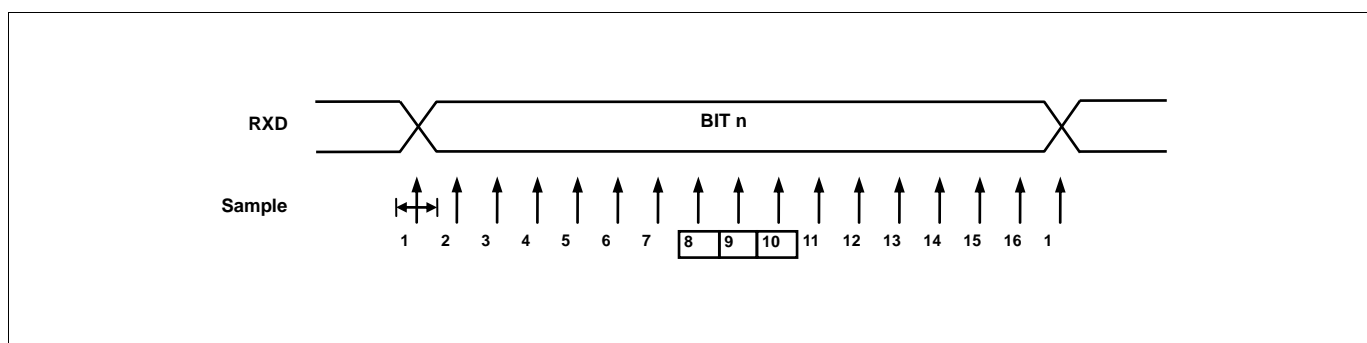

Figure 11-40. Sampling of Data and Parity Bit

The process for detecting stop bit is like clock and data recovery process. That is, if 2 or more samples of 3 center values have high level, correct stop bit is detected, else a frame error (FE) flag is set. After deciding whether the first stop bit is valid or not, the Receiver goes to idle state and monitors the RXD line to check a valid high to low transition is detected (start bit detection).

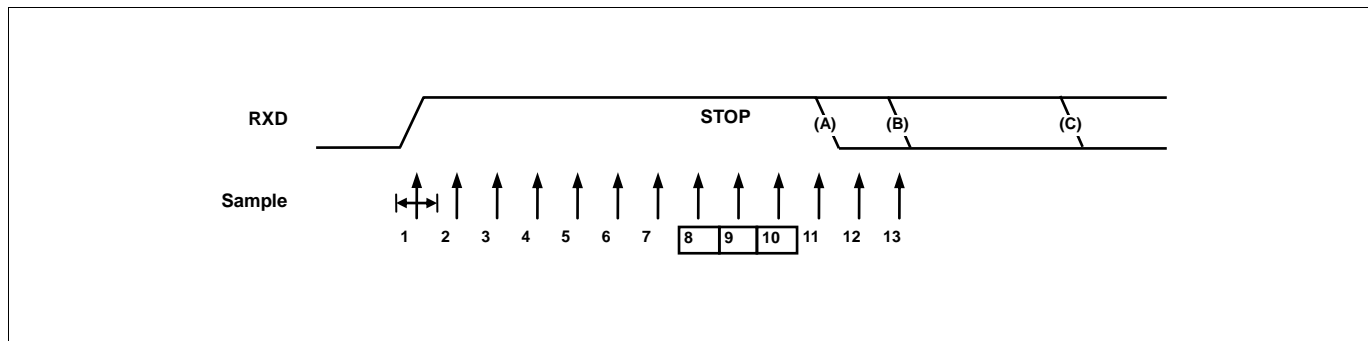

Figure 11-41. Stop Bit Sampling and Next Start Bit Sampling

11.12.10 Register Map

Name	Address	Dir	Default	Description
UARTBD	E6H	R/W	FFH	UART Baud Rate Generation Register
UARTDR	E7H	R/W	00H	UART Data Register
UARTCR1	E2H	R/W	00H	UART Control Register 1
UARTCR2	E3H	R/W	00H	UART Control Register 2
UARTCR3	E4H	R/W	00H	UART Control Register 3
UARTST	E5H	R/W	80H	UART Status Register

Table 11-17. UART Register Map

11.12.11 UART Register Description

UART module consists of UART baud rate generation register (UARTBD), UART data register (UARTDR), UART control register 1 (UARTCR1), UART control register 2 (UARTCR2), UART control register 3 (UARTCR3), and UART status register (UARTST).

11.12.12 Register Description for UART

UARTBD (UART Baud Rate Generation Register) : E6H

7	6	5	4	3	2	1	0
UARTBD7	UARTBD6	UARTBD5	UARTBD4	UARTBD3	UARTBD2	UARTBD1	UARTBD0
R/W	R/W	R/W	R/W	R/W	R/W	R/W	R/W

Initial value : FFH

UARTBD [7:0] The value in this register is used to generate internal baud rate in asynchronous mode. To prevent malfunction, do not write '0' in asynchronous mode.

UARTDR (UART Data Register) : E7H

7	6	5	4	3	2	1	0
UARTDR7	UARTDR6	UARTDR5	UARTDR4	UARTDR3	UARTDR2	UARTDR1	UARTDR0
RW	RW	RW	RW	RW	RW	RW	RW

Initial value : 00H

UARTDR [7:0] The UART Transmit Buffer and Receive Buffer share the same I/O address with this DATA register. The Transmit Data Buffer is the destination for data written to the UARTDR register. Reading the UDATA register returns the contents of the Receive Buffer.

Write this register only when the UDRE flag is set.

UARTCR1 (UART Control Register 1) : E2H

7	6	5	4	3	2	1	0
–	UMSEL	UPM1	UPM0	USIZE2	USIZE1	USIZE0	UCPOL
–	RW	RW	RW	RW	RW	RW	RW

Initial value : 00H

UMSEL Selects Operation Mode of UART

0 Asynchronous Mode

1 Synchronous Mode

UPM[1:0] Selects Parity Generation and Check methods

UPM1 UPM0 Parity

0 0 No Parity

0 1 Reserved

1 0 Even Parity

1 1 Odd Parity

USIZE[2:0] Selects the Length of Data Bits in Frame

USIZE2 USIZE1 USIZE0 Data Length

0 0 0 5 bit

0 0 1 6 bit

0 1 0 7 bit

0 1 1 8 bit

1 0 0 Reserved

1 0 1 Reserved

1 1 0 Reserved

1 1 1 9 bit

UCPOL Selects Polarity of ACK in Synchronous Mode

0 TXD change @Rising Edge, RXD change @Falling Edge

1 TXD change @Falling Edge, RXD change @Rising Edge

UARTCR2 (UART Control Register 2) : E3H

7	6	5	4	3	2	1	0
UDRIE	TXCIE	RXCIE	WAKEIE	TXE	RXE	UARTEN	U2X
RW	RW	RW	RW	RW	RW	RW	RW

Initial value : 00H

UDRIE	Interrupt enable bit for UART Data Register Empty 0 Interrupt from UDRE is inhibited (use polling) 1 When UDRE is set, request an interrupt
TXCIE	Interrupt enable bit for Transmit Complete 0 Interrupt from TXC is inhibited (use polling) 1 When TXC is set, request an interrupt
RXCIE	Interrupt enable bit for Receive Complete 0 Interrupt from RXC is inhibited (use polling) 1 When RXC is set, request an interrupt
WAKEIE	Interrupt enable bit for Asynchronous Wake in STOP mode. When device is in stop mode, if RXD goes to LOW level an interrupt can be requested to wake-up system. At that time the UDRIE bit and UARTST register value should be set to '0b' and "00H", respectively. 0 Interrupt from Wake is inhibited 1 When WAKE is set, request an interrupt
TXE	Enables the transmitter unit 0 Transmitter is disabled 1 Transmitter is enabled
RXE	Enables the receiver unit 0 Receiver is disabled 1 Receiver is enabled
UARTEN	Activate UART module by supplying clock. When one of TXE and RXE values is "1", the UARTEN bit always set to "1". 0 USART is disabled (clock is halted) 1 USART is enabled
U2X	This bit only has effect for the asynchronous operation and selects receiver sampling rate. 0 Normal asynchronous operation 1 Double Speed asynchronous operation

UARTCR3 (UART Control Register 3) : E4H

7	6	5	4	3	2	1	0
MASTER	LOOPS	DISACK	–	–	USBS	TX8	RX8
RW	RW	RW	–	–	RW	RW	R

Initial value : 00H

- MASTER** Selects master or slave in Synchronous mode operation and controls the direction of ACK pin
 - 0 Slave mode operation and ACK is input pin.
 - 1 Master mode operation and ACK is output pin
- LOOPS** Controls the Loop Back Mode of UART, for test mode
 - 0 Normal operation
 - 1 Loop Back mode
- DISACK** In Synchronous mode of operation, selects the waveform of ACK output
 - 0 ACK is free-running while UART is enabled in synchronous master mode
 - 1 ACK is active while any frame is on transferring
- USBS** Selects the length of stop bit.
 - 0 1 Stop Bit
 - 1 2 Stop Bit
- TX8** The ninth bit of data frame in UART. Write this bit first before loading the UARTDR register
 - 0 MSB (9th bit) to be transmitted is '0'
 - 1 MSB (9th bit) to be transmitted is '1'
- RX8** The ninth bit of data frame in UART. Read this bit first before reading the receive buffer
 - 0 MSB (9th bit) received is '0'
 - 1 MSB (9th bit) received is '1'

UARTST (UART Status Register) : E5H

7	6	5	4	3	2	1	0
UDRE	TXC	RXC	WAKE	SOFTRST	DOR	FE	PE
RW	RW	R	RW	RW	R	RW	RW

Initial value : 80H

UDRE	The UDRE flag indicates if the transmit buffer (UARTDR) is ready to receive new data. If UDRE is '1', the buffer is empty and ready to be written. This flag can generate a UDRE interrupt. 0 Transmit buffer is not empty. 1 Transmit buffer is empty.
TXC	This flag is set when the entire frame in the transmit shift register has been shifted out and there is no new data currently present in the transmit buffer. This flag is automatically cleared when the interrupt service routine of a TXC interrupt is executed. This flag can generate a TXC interrupt. This bit is automatically cleared. 0 Transmission is ongoing. 1 Transmit buffer is empty and the data in transmit shift register are shifted out completely.
RXC	This flag is set when there are unread data in the receive buffer and cleared when all the data in the receive buffer are read. The RXC flag can be used to generate a RXC interrupt. 0 There is no data unread in the receive buffer 1 There are more than 1 data in the receive buffer
WAKE	This flag is set when the RX pin is detected low while the CPU is in stop mode. This flag can be used to generate a WAKE interrupt. This bit is set only when in asynchronous mode of operation. This bit should be cleared by program software. 0 No WAKE interrupt is generated. 1 WAKE interrupt is generated
SOFTRST	This is an internal reset and only has effect on UART. Writing '1' to this bit initializes the internal logic of UART and this bit is automatically cleared. 0 No operation 1 Reset UART
DOR	This bit is set if a Data Overrun occurs. While this bit is set, the incoming data frame is ignored. This flag is valid until the receive buffer is read. 0 No Data Overrun 1 Data Overrun detected
FE	This bit is set if the first stop bit of next character in the receive buffer is detected as '0'. This bit is valid until the receive buffer is read. 0 No Frame Error 1 Frame Error detected
PE	This bit is set if the next character in the receive buffer has a Parity Error to be received while Parity Checking is enabled. This bit is valid until the receive buffer is read. 0 No Parity Error 1 Parity Error detected

11.12.13 Baud Rate setting (example)

Baud Rate	fx=1.00MHz		fx=1.8432MHz		fx=2.00MHz	
	UARTBD	ERROR	UARTBD	ERROR	UARTBD	ERROR
2400	25	0.2%	47	0.0%	51	0.2%
4800	12	0.2%	23	0.0%	25	0.2%
9600	6	-7.0%	11	0.0%	12	0.2%
14.4k	3	8.5%	7	0.0%	8	-3.5%
19.2k	2	8.5%	5	0.0%	6	-7.0%
28.8k	1	8.5%	3	0.0%	3	8.5%
38.4k	1	-18.6%	2	0.0%	2	8.5%
57.6k	-	-	1	-25.0%	1	8.5%
76.8k	-	-	1	0.0%	1	-18.6%
115.2k	-	-	-	-	-	-
230.4k	-	-	-	-	-	-

Table 11-18. Examples of UARTBD Settings for Commonly Used Oscillator Frequencies

Baud Rate	fx=3.6864MHz		fx=4.00MHz		fx=7.3728MHz	
	UARTBD	ERROR	UARTBD	ERROR	UARTBD	ERROR
2400	95	0.0%	103	0.2%	191	0.0%
4800	47	0.0%	51	0.2%	95	0.0%
9600	23	0.0%	25	0.2%	47	0.0%
14.4k	15	0.0%	16	2.1%	31	0.0%
19.2k	11	0.0%	12	0.2%	23	0.0%
28.8k	7	0.0%	8	-3.5%	15	0.0%
38.4k	5	0.0%	6	-7.0%	11	0.0%
57.6k	3	0.0%	3	8.5%	7	0.0%
76.8k	2	0.0%	2	8.5%	5	0.0%
115.2k	1	0.0%	1	8.5%	3	0.0%
230.4k	-	-	-	-	1	0.0%
250k	-	-	-	-	1	-7.8%
0.5M	-	-	-	-	-	-

(continued)

Baud Rate	fx=8.00MHz		fx=11.0592MHz	
	UARTBD	ERROR	UARTBD	ERROR
2400	207	0.2%	-	-
4800	103	0.2%	143	0.0%
9600	51	0.2%	71	0.0%
14.4k	34	-0.8%	47	0.0%
19.2k	25	0.2%	35	0.0%
28.8k	16	2.1%	23	0.0%
38.4k	12	0.2%	17	0.0%
57.6k	8	-3.5%	11	0.0%
76.8k	6	-7.0%	8	0.0%
115.2k	3	8.5%	5	0.0%
230.4k	1	8.5%	2	0.0%
250k	1	0.0%	2	-7.8%
0.5M	-	-	-	-

(continued)

11.13 LCD Driver

11.13.1 Overview

The LCD driver is controlled by the LCD Control Register (LCDCRH/L). The LCLK[1:0] determines the frequency of COM signal scanning of each segment output. A RESET clears the LCD control register LCDCRH and LCDCRL values to logic '0'.

The LCD display can continue operating during IDLE and STOP modes if a sub-frequency clock is used as system clock source.

The clock and duty for LCD driver is automatically initialized by hardware, whenever LCDCRH register data value is rewritten. So, don't rewrite LCDCRH frequently.

11.13.2 LCD Display RAM Organization

Display data are stored to the display data area in the external data memory.

The display data which stored to the display external data area (address 0000H-0027H) are read automatically and sent to the LCD driver by the hardware. The LCD driver generates the segment signals and common signals in accordance with the display data and drive method. Therefore, display patterns can be changed by only overwriting the contents of the display external data area with a program.

Figure 11-42 shows the correspondence between the display external data area and the COM/SEG pins. The LCD is turned on when the display data is “1” and turned off when “0”.

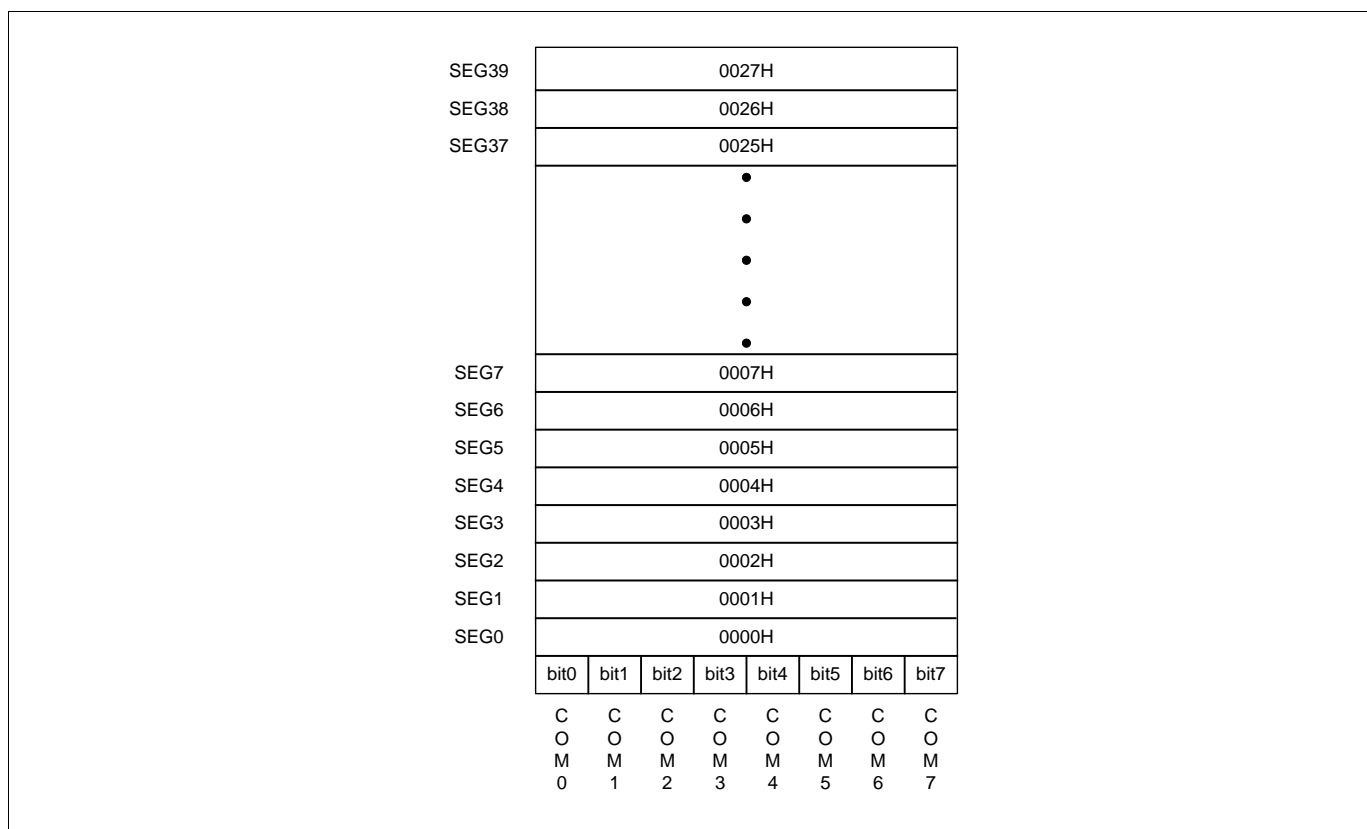

Figure 11-42. LCD Display Data Ram Organization

11.13.3 LCD Signal Waveform

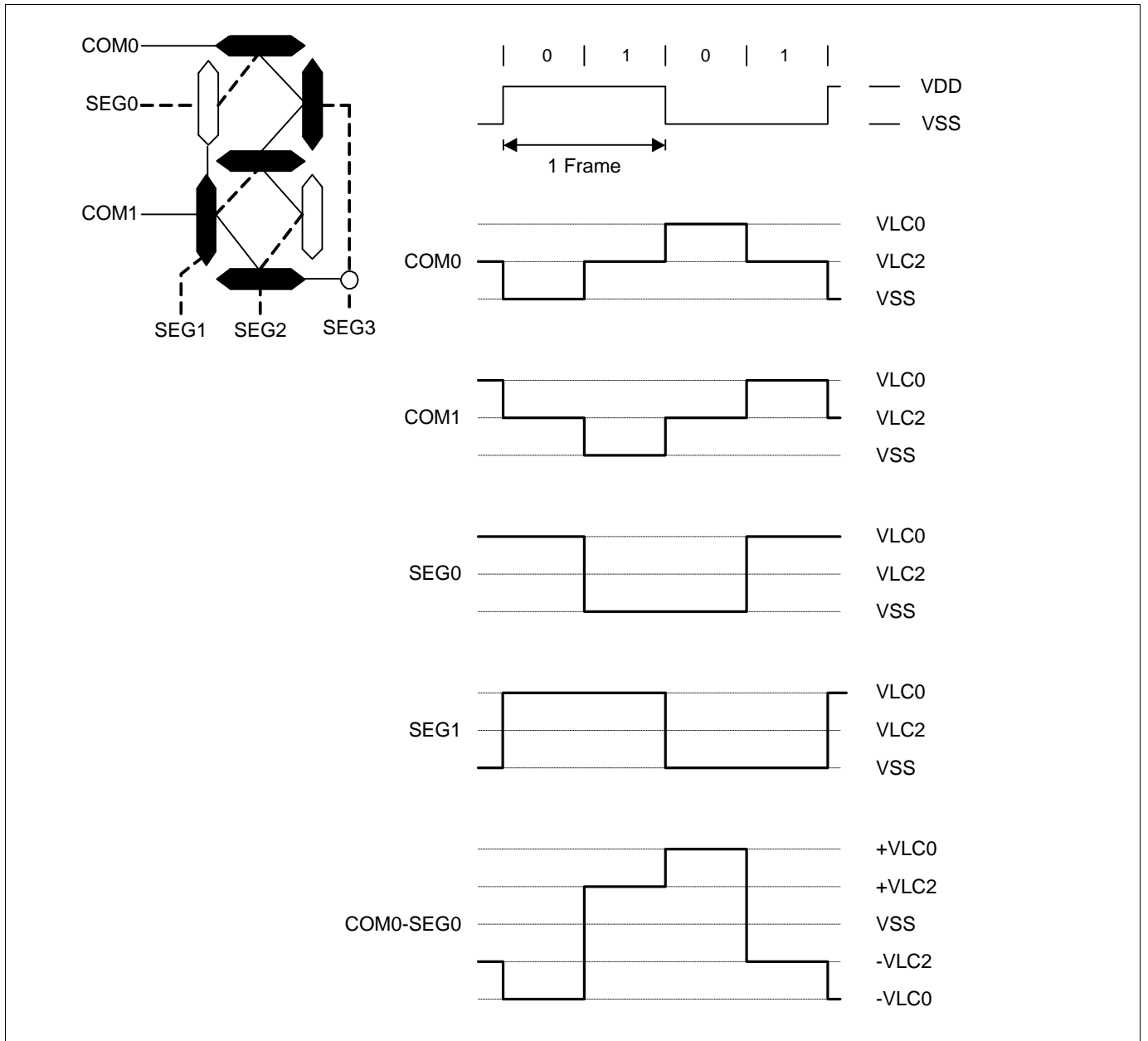

Figure 11-43. LCD Signal Waveforms (1/2Duty, 1/2Bias)

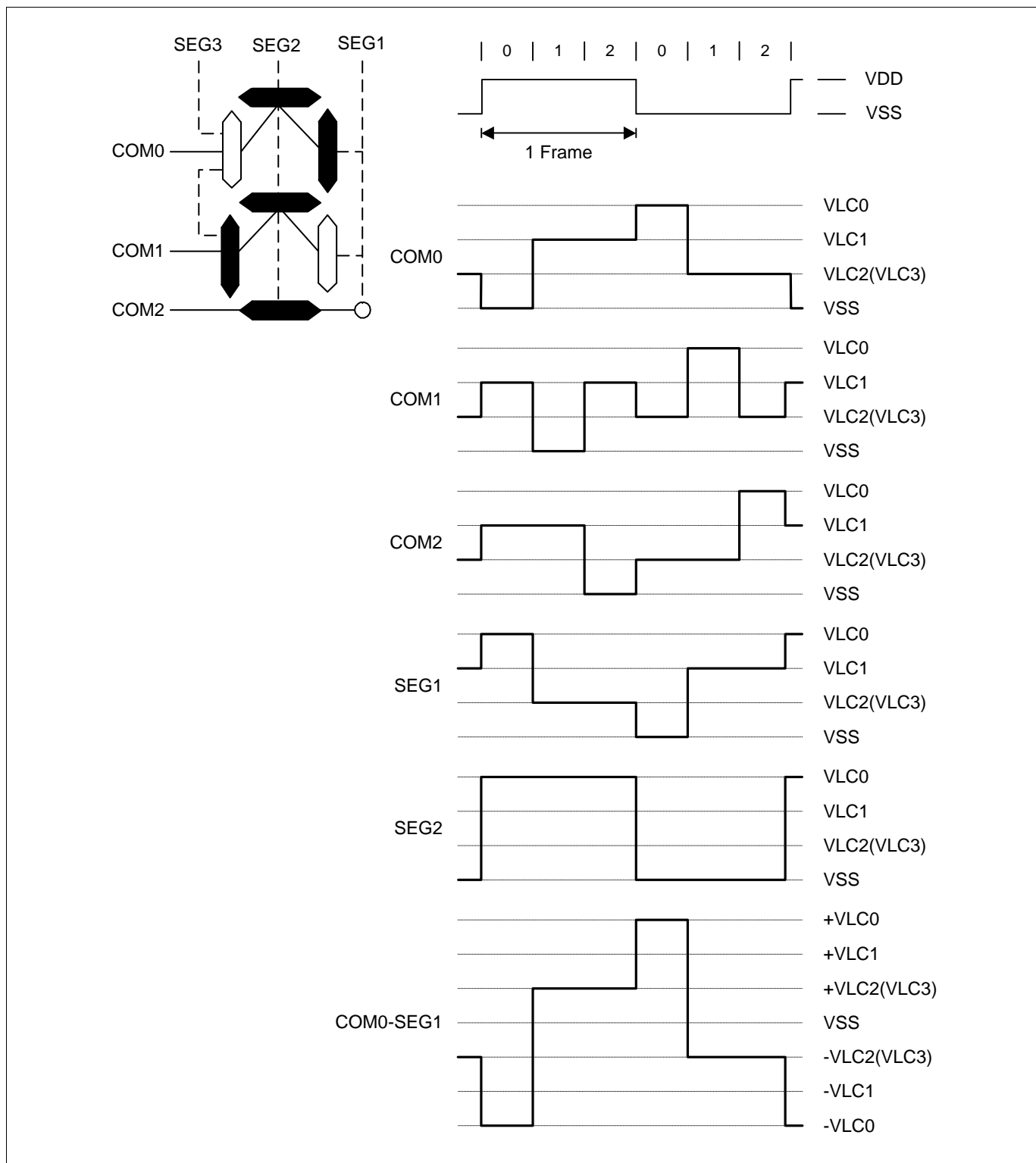

Figure 11-44. LCD Signal Waveforms (1/3Duty, 1/3Bias)

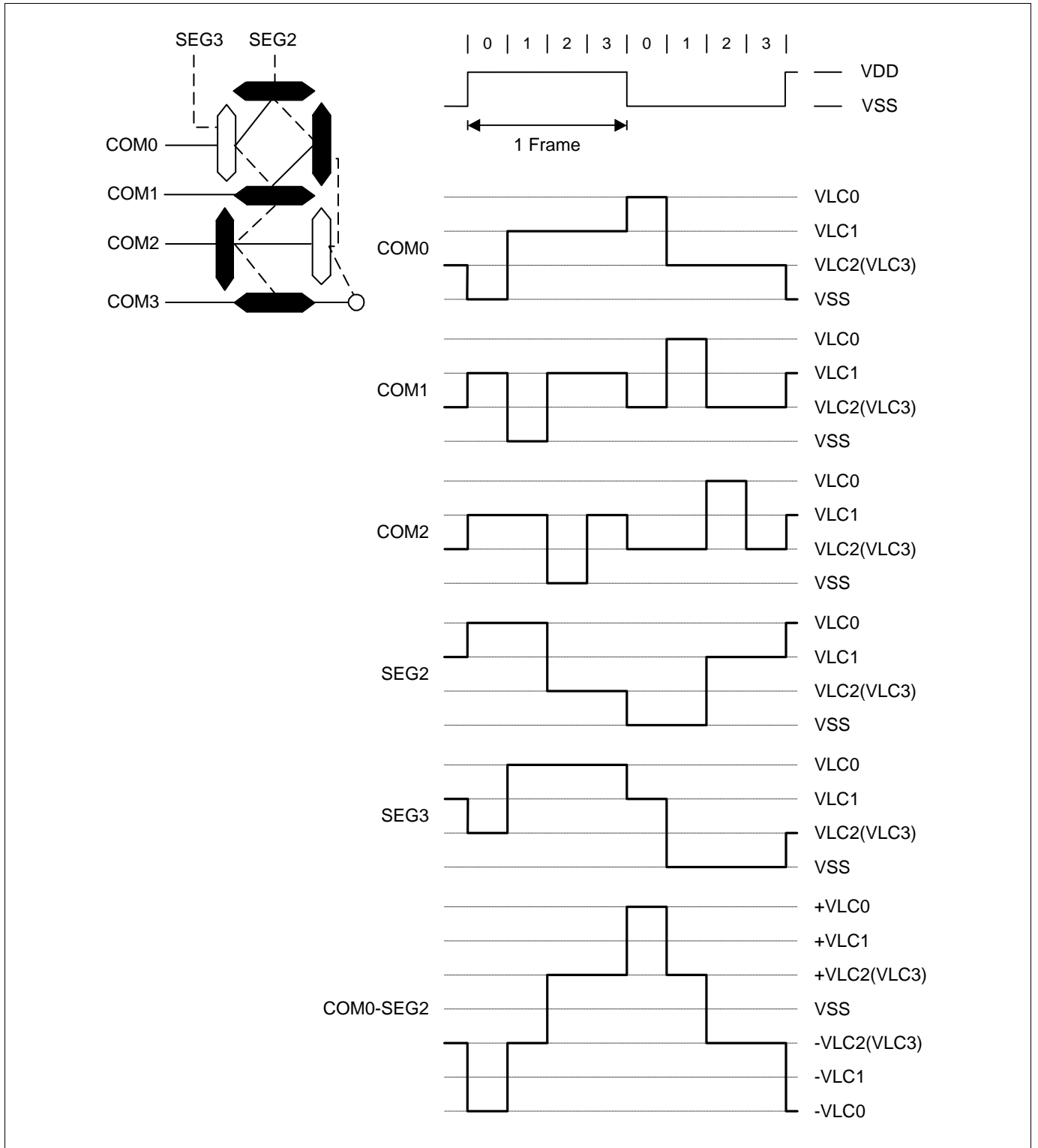

Figure 11-45. LCD Signal Waveforms (1/4Duty, 1/3Bias)

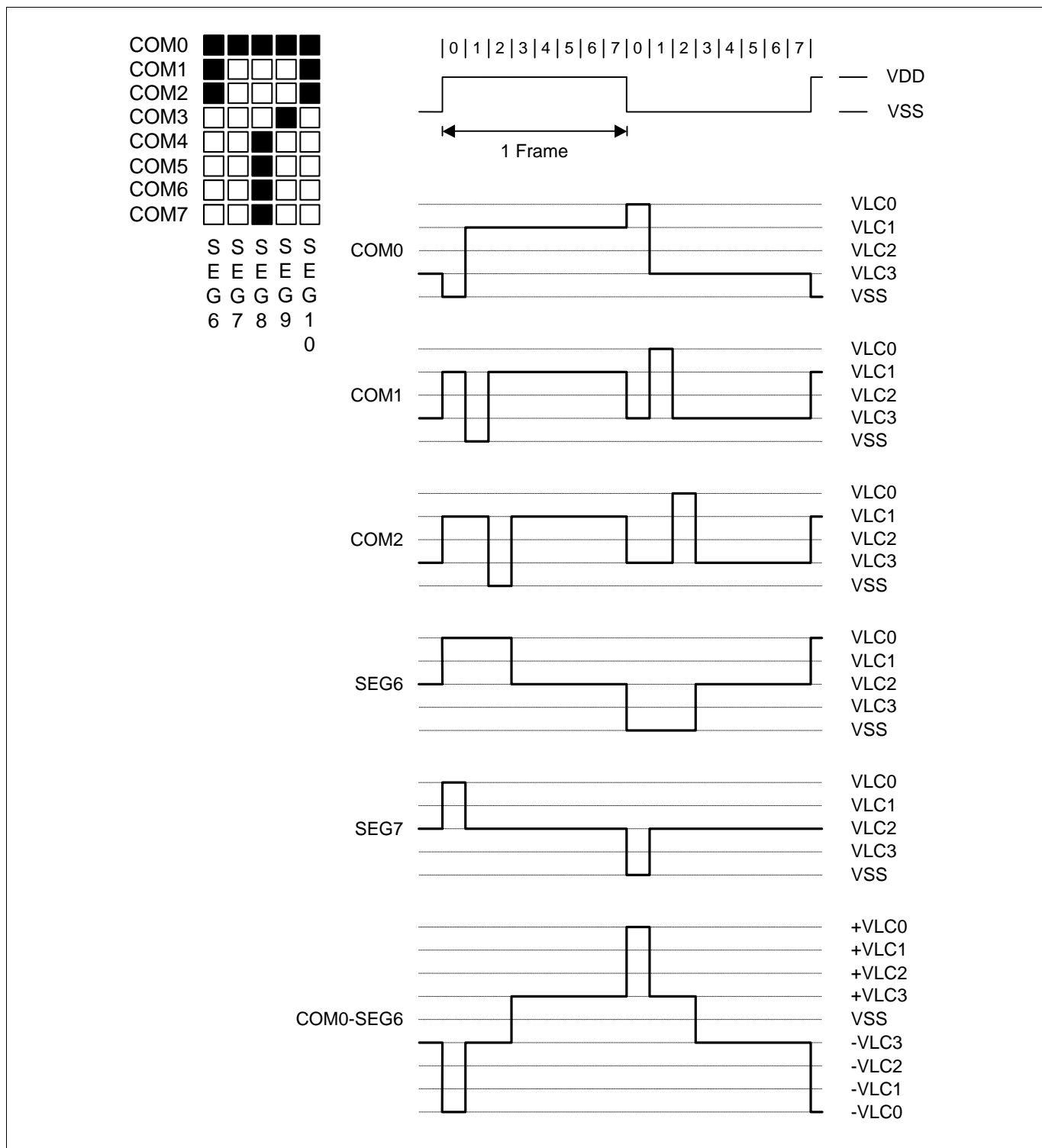

Figure 11-46. LCD Signal Waveforms (1/8Duty, 1/4Bias)

11.13.4 LCD Voltage Dividing Resistor Connection

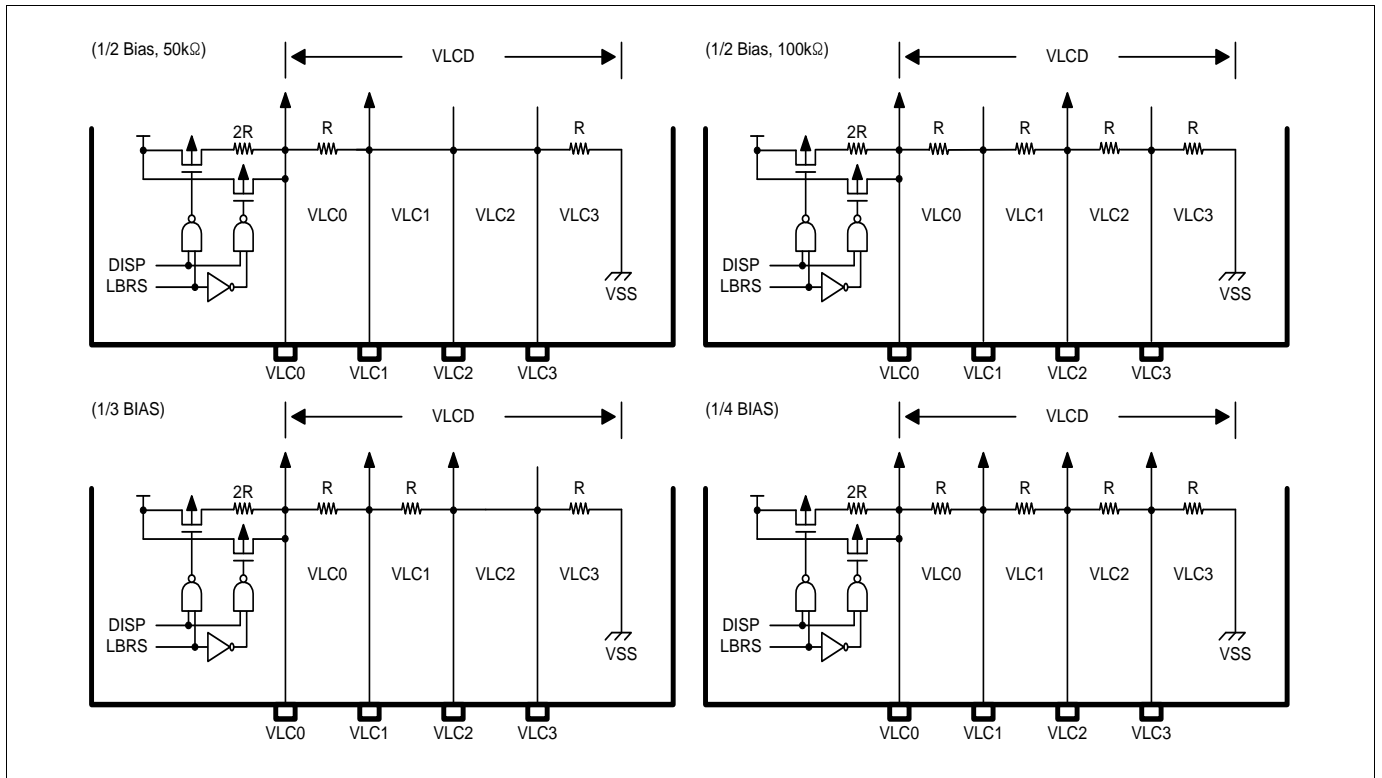

Figure 11-47. Internal Resistor Bias Connection

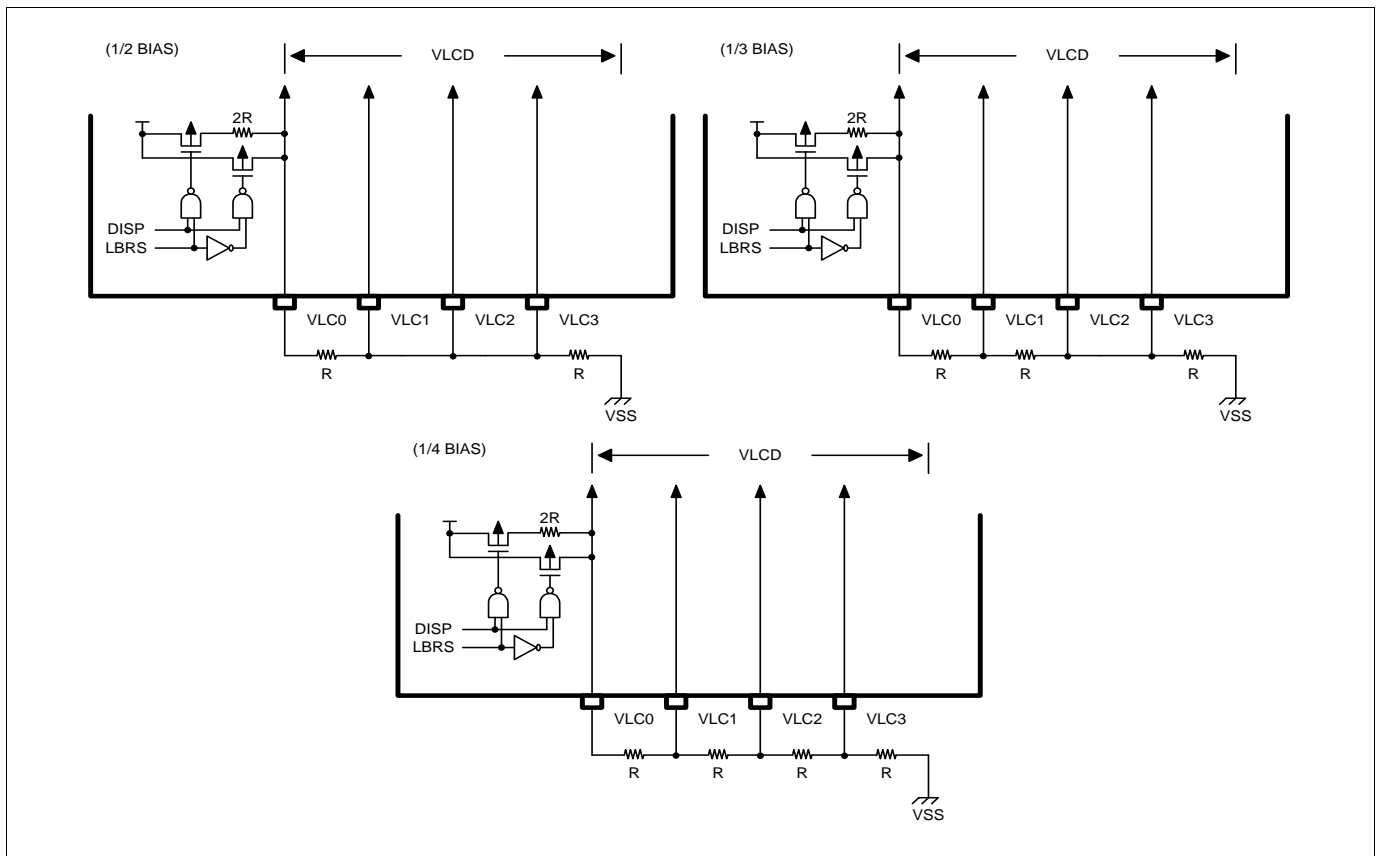

Figure 11-48. External Resistor Bias Connection

11.13.5 Block Diagram

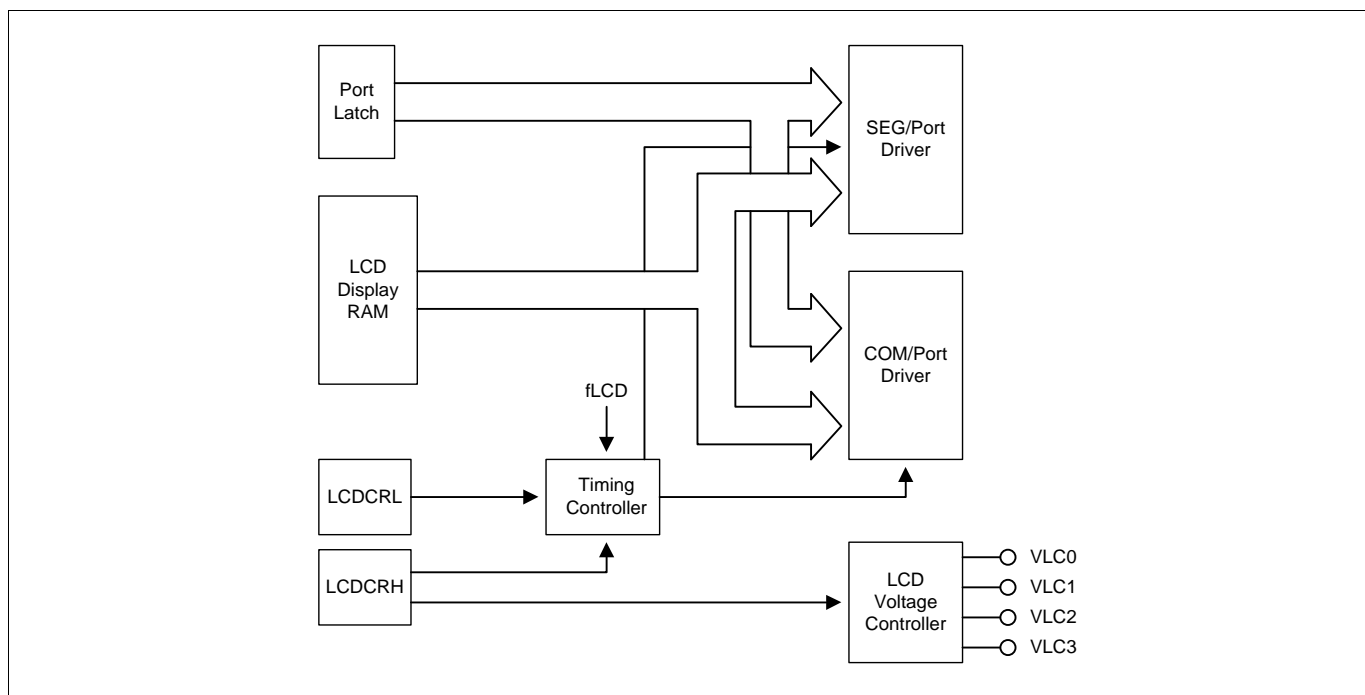

Figure 11-49. LCD Circuit Block Diagram

NOTE)

1. The clock and duty for LCD driver is automatically initialized by hardware, whenever LCDCRH register data value is rewritten. So, don't rewrite LCDCRH frequently

11.13.6 Register Map

Name	Address	Dir	Default	Description
LCDCRH	ECH	R/W	00H	LCD Driver Control High Register
LCDCRL	EBH	R/W	00H	LCD Driver Control Low Register

Table 11-19. LCD Register Map

11.13.7 LCD Driver Register Description

LCD driver register has two control registers, LCD driver control high register (LCDCRH) and LCD driver control low register (LCDCRL).

11.13.8 Register Description for LCD Driver

LCDCRH (LCD Driver Control High Register) : ECH

7	6	5	4	3	2	1	0
LCDDR	LD_B3	LD_B2	LD_B1	LD_B0	LCLK1	LCLK0	DISP
RW	RW	R/W	RW	RW	RW	RW	RW

Initial value : 00H

LCDDR	LCD Driving Resistor for Bias Select				
0	Internal LCD driving resistors for bias				
1	External LCD driving resistor for bias				
LD_B[3:0]	LCD Duty and Bias Select (NOTE)				
LD_B3	LD_B2	LD_B1	LD_B0	Description	
0	0	0	0	1/2Duty, 1/2Bias (100kΩ)	
0	0	0	1	1/2Duty, 1/2Bias (50kΩ)	
0	0	1	0	1/2Duty, 1/3Bias (50kΩ)	
0	0	1	1	1/3Duty, 1/2Bias (100kΩ)	
0	1	0	0	1/3Duty, 1/2Bias (50kΩ)	
0	1	0	1	1/3Duty, 1/3Bias (50kΩ)	
0	1	1	0	1/4Duty, 1/2Bias (100kΩ)	
0	1	1	1	1/4Duty, 1/2Bias (50kΩ)	
1	0	0	0	1/4Duty, 1/3Bias (50kΩ)	
1	0	0	1	Not available	
1	0	1	0	Not available	
1	0	1	1	1/5Duty, 1/3Bias (50kΩ)	
1	1	0	0	1/6Duty, 1/3Bias (50kΩ)	
1	1	0	1	1/6Duty, 1/4Bias (50kΩ)	
1	1	1	0	1/8Duty, 1/3Bias (50kΩ)	
1	1	1	1	1/8Duty, 1/4Bias (50kΩ)	
LCLK[1:0]	LCD Clock Select (When f_{WCK} (Watch timer clock)= 32.768kHz)				
LCLK1	LCLK0	Description			
0	0	$f_{LCD} = 128\text{Hz}$			
0	1	$f_{LCD} = 256\text{Hz}$			
1	0	$f_{LCD} = 512\text{Hz}$			
1	1	$f_{LCD} = 1024\text{Hz}$			
NOTE)					
1. The LCD clock is generated by watch timer clock (f_{WCK}). So the watch timer should be enabled when the LCD display is turned on.					
DISP	LCD Display Control				
0	Display off				
1	Normal display on				

NOTE)

- When 1/2 bias is selected, the bias levels are set as VLC0, VLC2, and VSS
- When 1/3 bias is selected, the bias levels are set as VLC0, VLC1, VLC2 (=VLC3), and VSS
- When 1/4 bias is selected, the bias levels are set as VLC0, VLC1, VLC2, VLC3, and VSS
- The bias levels are automatically set with appropriate bias circuit when internal bias resistors are used.
- A bias circuit is connected like the "11.13.4 LCD Voltage Dividing Resistor Connection" and should be selected as an appropriate value for "LD_B[3:0]".

LCD Clock Frequency (f _{LCD})	LCD Frame Frequency (f _{FRAME})						Unit
	1/2 Duty	1/3 Duty	1/4 Duty	1/5 Duty	1/6 Duty	1/8 Duty	
128	64	43	32	26	21	16	Hz
256	128	85	64	51	43	32	
512	256	171	128	102	85	64	
1024	512	341	256	205	171	128	

Table 11-20. LCD Frame Frequency

The LCD frame frequency is calculated by the following formula:

$$\text{LCD Frame Frequency (f}_{\text{FRAME}}) = \text{f}_{\text{LCD}} \times \text{Duty[Hz]}$$

Ex) In case of 1/4 duty and f_{LCD} = 512Hz, f_{FRAME} = f_{LCD} × 1/4 = 512 × 1/4 = 128Hz

LDCRLL (LCD Driver Control Low Register) : EBH

7	6	5	4	3	2	1	0
–	–	–	–	–	–	LBRS	VLC_PE
–	–	–	–	–	–	RW	RW

Initial value : 00H

- LBRS** LCD Bias Resistor Select
 - 0 Not select 2R
 - 1 Select 2R
- VLC_PE** VLC[3:0] Port Control
 - 0 Normal Port
 - 1 VLCD[3:0] pin

12 Power Down Operation

12.1 Overview

The MC96F6632S has two power-down modes to minimize the power consumption of the device. In power down mode, power consumption is reduced considerably. The device provides three kinds of power saving functions, Main-IDLE, Sub-IDLE and STOP mode. In three modes, program is stopped.

12.2 Peripheral Operation in IDLE/STOP Mode

Peripheral	IDLE Mode	STOP Mode
CPU	ALL CPU Operation are Disable	ALL CPU Operation are Disable
RAM	Retain	Retain
Basic Interval Timer	Operates Continuously	Stop
Watch Dog Timer	Operates Continuously	Stop (Can be operated with WDTRC OSC)
Watch Timer	Operates Continuously	Stop (Can be operated with sub clock)
Timer0~3	Operates Continuously	Halted (Only when the Event Counter Mode is Enabled, Timer operates Normally)
ADC	Operates Continuously	Stop
BUZ	Operates Continuously	Stop
SIO	Operates Continuously	Only operate with external clock
UART	Operates Continuously	Stop
LCD Controller	Operates Continuously	Stop (Can be operated with sub clock)
Internal OSC (8MHz)	Oscillation	Stop when the system clock (fx) is f _{IRC}
WDTRC OSC (5kHz)	Stop	Can be operated with setting value
Main OSC (1~12MHz)	Oscillation	Stop when fx = f _{XIN}
Sub OSC (32.768kHz)	Oscillation	Stop when fx = f _{SUB}
I/O Port	Retain	Retain
Control Register	Retain	Retain
Address Data Bus	Retain	Retain
Release Method	By RESET, all Interrupts	By RESET, Timer Interrupt (EC0,EC3), SIO (External clock), External Interrupt, UART by RX, WT (sub clock), WDT

Table 12-1. Peripheral Operation during Power Down Mode

12.3 IDLE Mode

The power control register is set to '01h' to enter the IDLE Mode. In this mode, the internal oscillation circuits remain active. Oscillation continues and peripherals are operated normally but CPU stops. It is released by reset or interrupt. To be released by interrupt, interrupt should be enabled before IDLE mode. If using reset, because the device becomes initialized state, the registers have reset value.

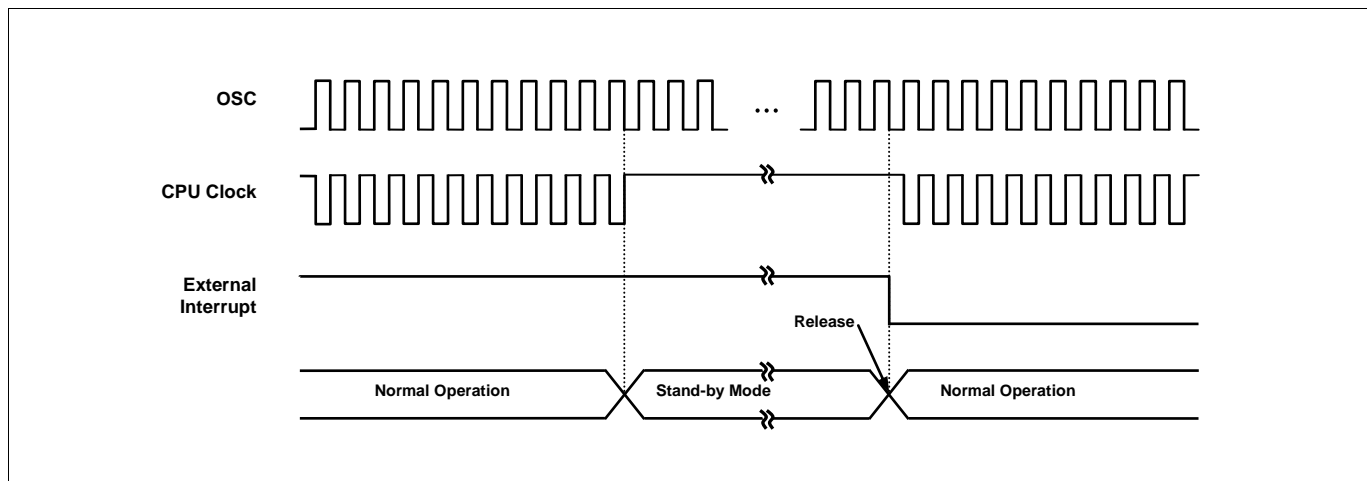

Figure 12-1. IDLE Mode Release Timing by External Interrupt

12.4 STOP Mode

The power control register is set to '03H' to enter the STOP Mode. In the stop mode, the selected oscillator, system clock and peripheral clock is stopped, but watch timer can be continued to operate with sub clock. With the clock frozen, all functions are stopped, but the on-chip RAM and control registers are held. For example, If the internal RC oscillator (f_{IRC}) is selected for the system clock and the sub clock (f_{SUB}) is oscillated, the internal RC oscillator stops oscillation and the sub clock is continuously oscillated in stop mode. At that time, the watch timer and LCD controller can be operated with the sub clock.

The source for exit from STOP mode is hardware reset and interrupts. The reset re-defines all the control registers. When exit from STOP mode, enough oscillation stabilization time is required to normal operation. Figure 12.2 shows the timing diagram. When released from STOP mode, the Basic interval timer is activated on wake-up. Therefore, before STOP instruction, user must be set its relevant prescale divide ratio to have long enough time. This guarantees that oscillator has started and stabilized.

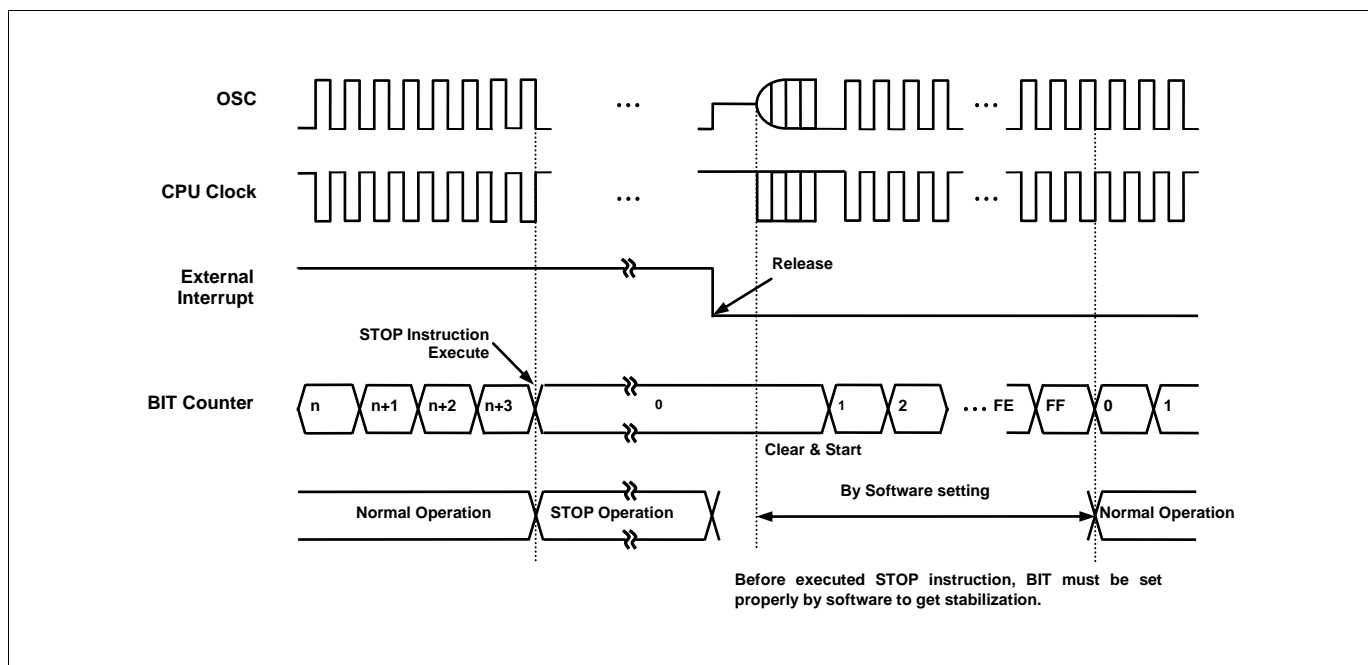

Figure 12-2. STOP Mode Release Timing by External Interrupt

12.5 Release Operation of STOP Mode

After STOP mode is released, the operation begins according to content of related interrupt register just before STOP mode start (Figure 12.3). If the global interrupt Enable Flag (IE.EA) is set to '1', the STOP mode is released by the interrupt which each interrupt enable flag = '1' and the CPU jumps to the relevant interrupt service routine. Even if the IE.EA bit is cleared to '0', the STOP mode is released by the interrupt of which the interrupt enable flag is set to '1'.

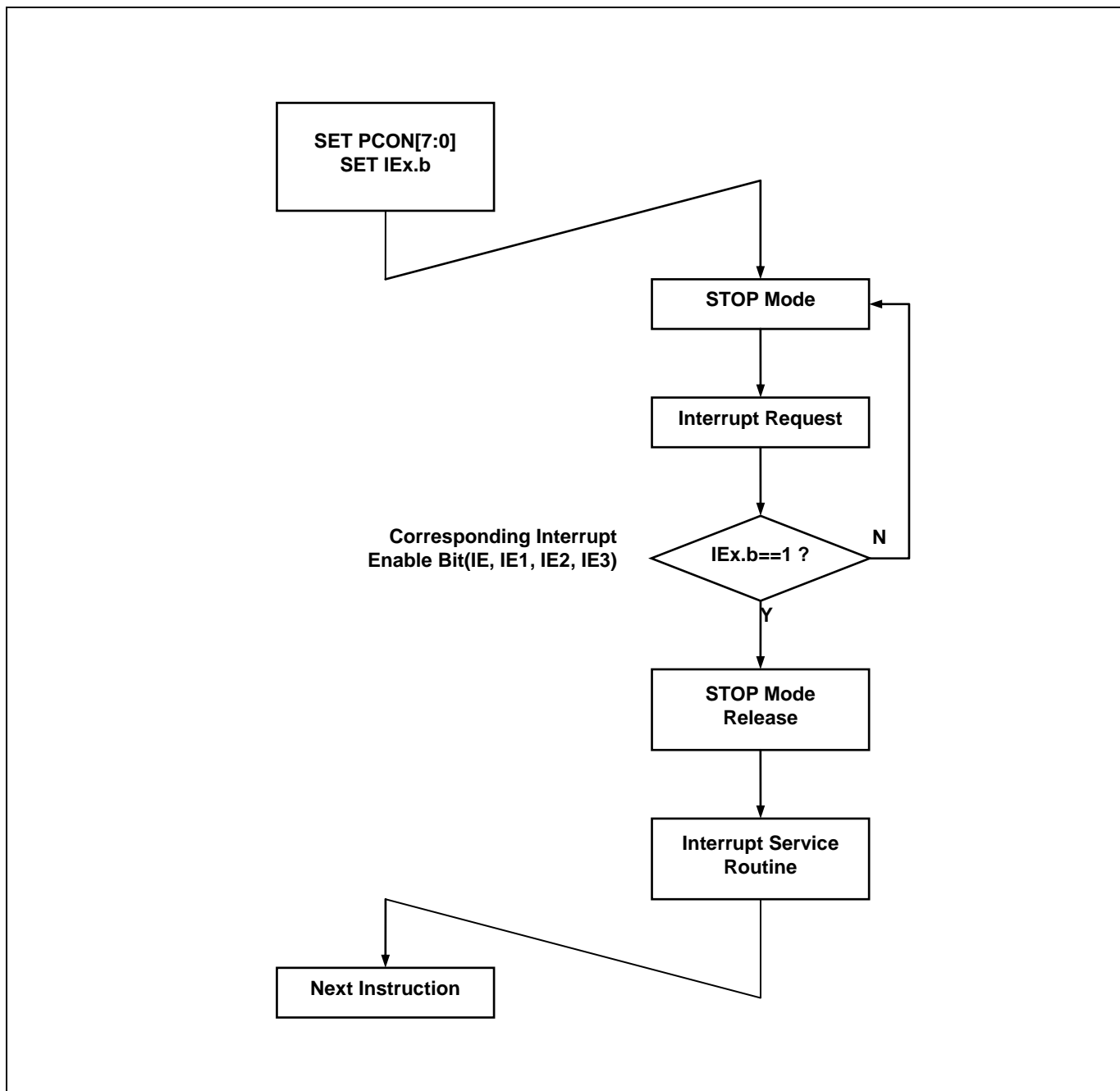

Figure 12-3. STOP Mode Release Flow

12.6 Register Map

Name	Address	Dir	Default	Description
PCON	87H	R/W	00H	Power Control Register

Table 12-2. Power Down Operation Register Map

12.7 Power Down Operation Register Description

The power down operation register consists of the power control register (PCON).

12.8 Register Description for Power Down Operation

PCON (Power Control Register) : 87H

7	6	5	4	3	2	1	0
PCON7	–	–	–	PCON3	PCON2	PCON1	PCON0
RW	–	–	–	RW	RW	RW	RW

Initial value : 00H

PCON[7:0] Power Control
 01H IDLE mode enable
 03H STOP mode enable

NOTE)

1. To enter IDLE mode, PCON must be set to '01H'.
2. To enter STOP mode, PCON must be set to '03H'.
3. The PCON register is automatically cleared by a release signal in STOP/IDLE mode.
4. Three or more NOP instructions must immediately follow the instruction that make the device enter STOP/IDLE mode. Refer to the following examples.

Ex1) MOV PCON, #01H; IDLE mode
 NOP
 NOP
 NOP
 .
 .
 .

Ex2) MOV PCON, #03H; STOP mode
 NOP
 NOP
 NOP
 .
 .
 .

13 RESET

13.1 Overview

On Chip Hardware	Initial Value
Program Counter (PC)	0000h
Accumulator	00h
Stack Pointer (SP)	07h
Peripheral Clock	On
Control Register	Refer to the Peripheral Registers

Table 13-1. Reset State

13.2 Reset Source

The MC96F6632S has four types of reset sources. The following is the reset sources.

- External RESETB
- Power ON RESET (POR)
- WDT Overflow Reset (In the case of WDTEN = `1`)
- Low Voltage Reset (In the case of LVREN = `0`)

13.3 RESET Block Diagram

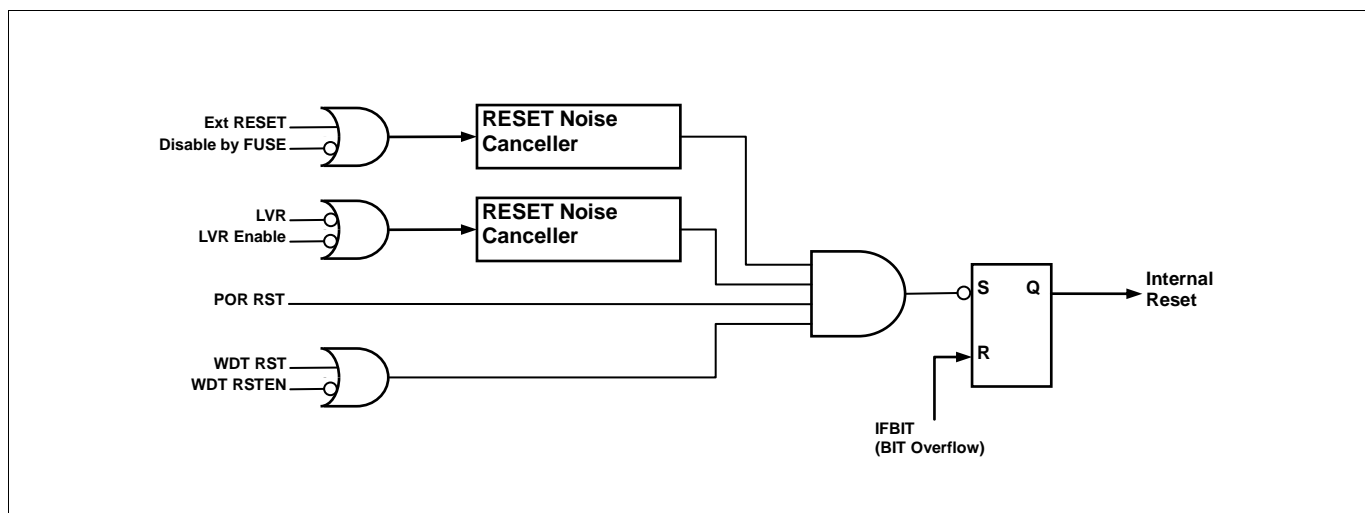

Figure 13-1. RESET Block Diagram

13.4 RESET Noise Canceller

The Figure 13.2 is the noise canceller diagram for noise cancellation of RESET. It has the noise cancellation value of about 2 μ s (@ $V_{DD}=5V$) to the low input of system reset.

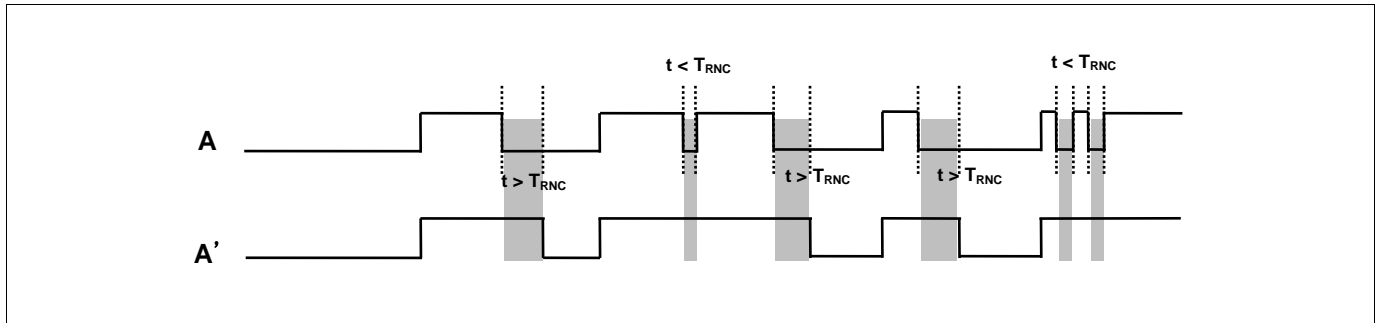

Figure 13-2. Reset noise canceller timer diagram

13.5 Power On RESET

When rising device power, the POR (Power On Reset) has a function to reset the device. If POR is used, it executes the device RESET function instead of the RESET IC or the RESET circuits.

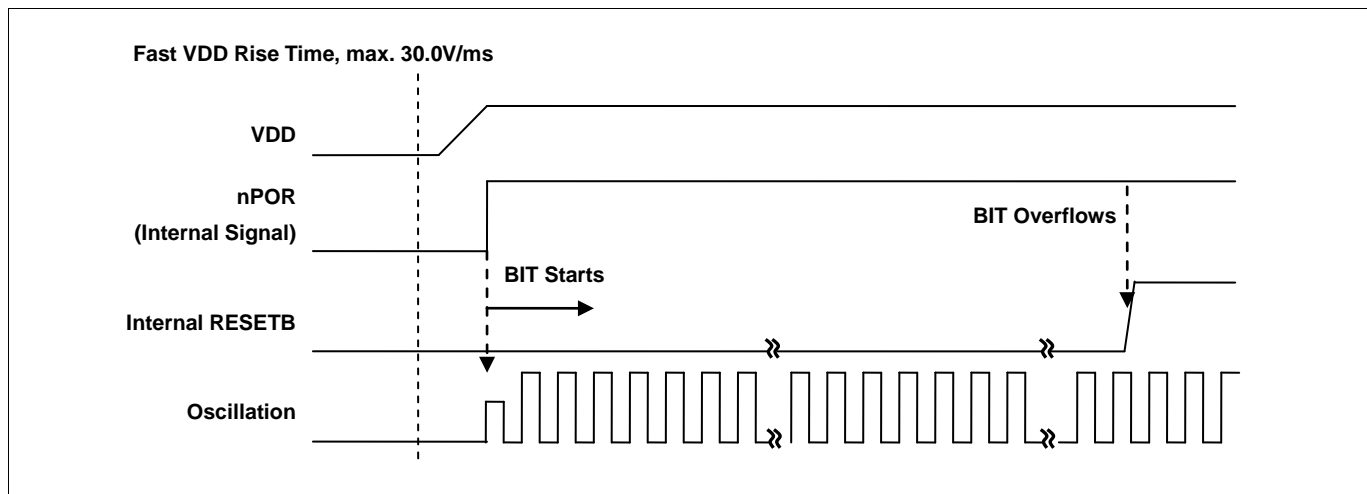

Figure 13-3. Fast VDD Rising Time

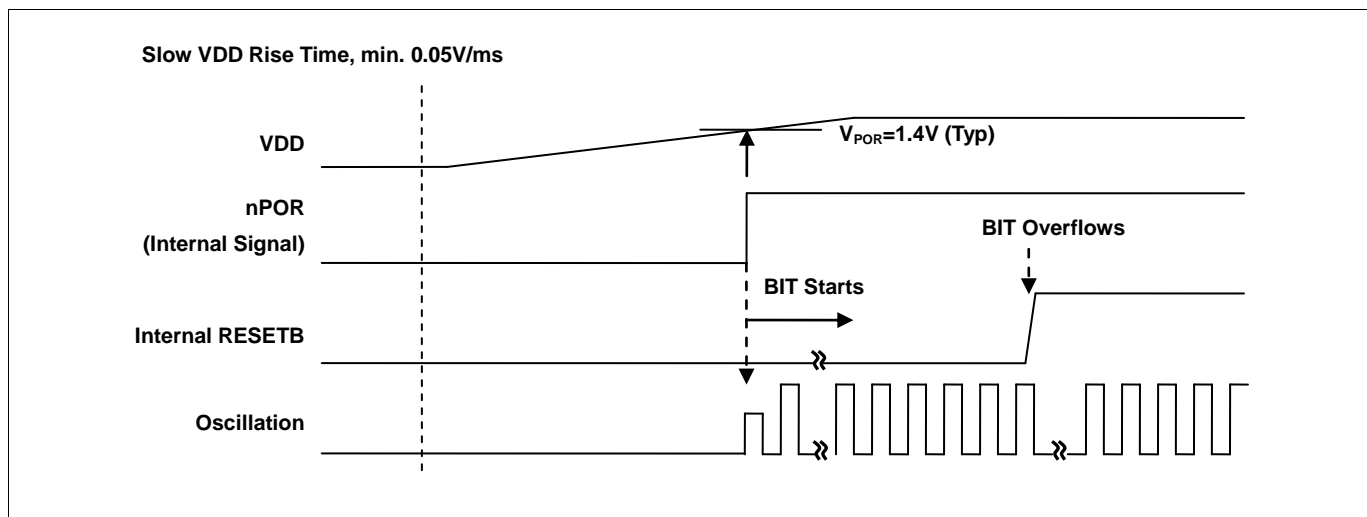

Figure 13-4. Internal RESET Release Timing On Power-Up

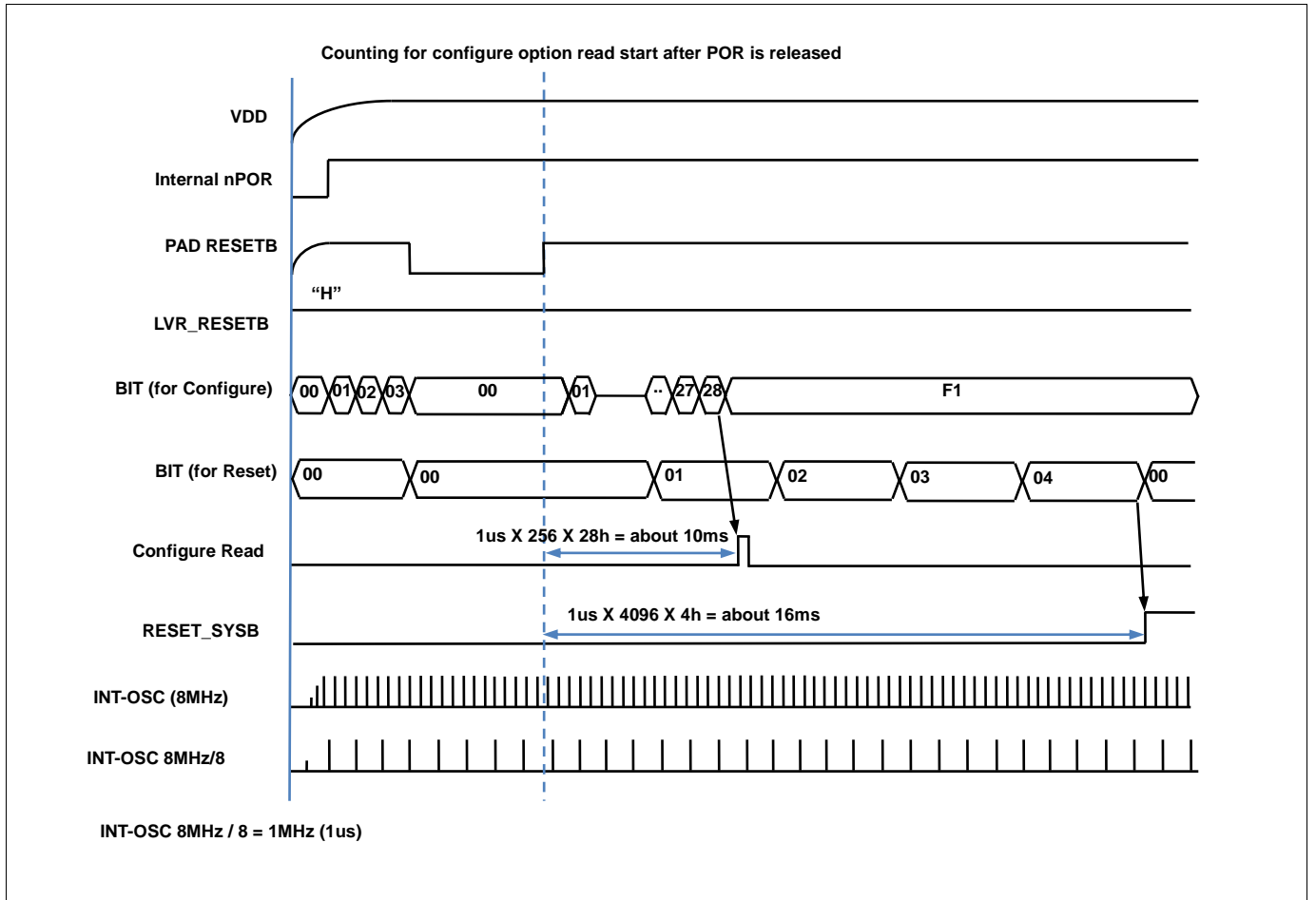

Figure 13-5. Configuration Timing when Power-on

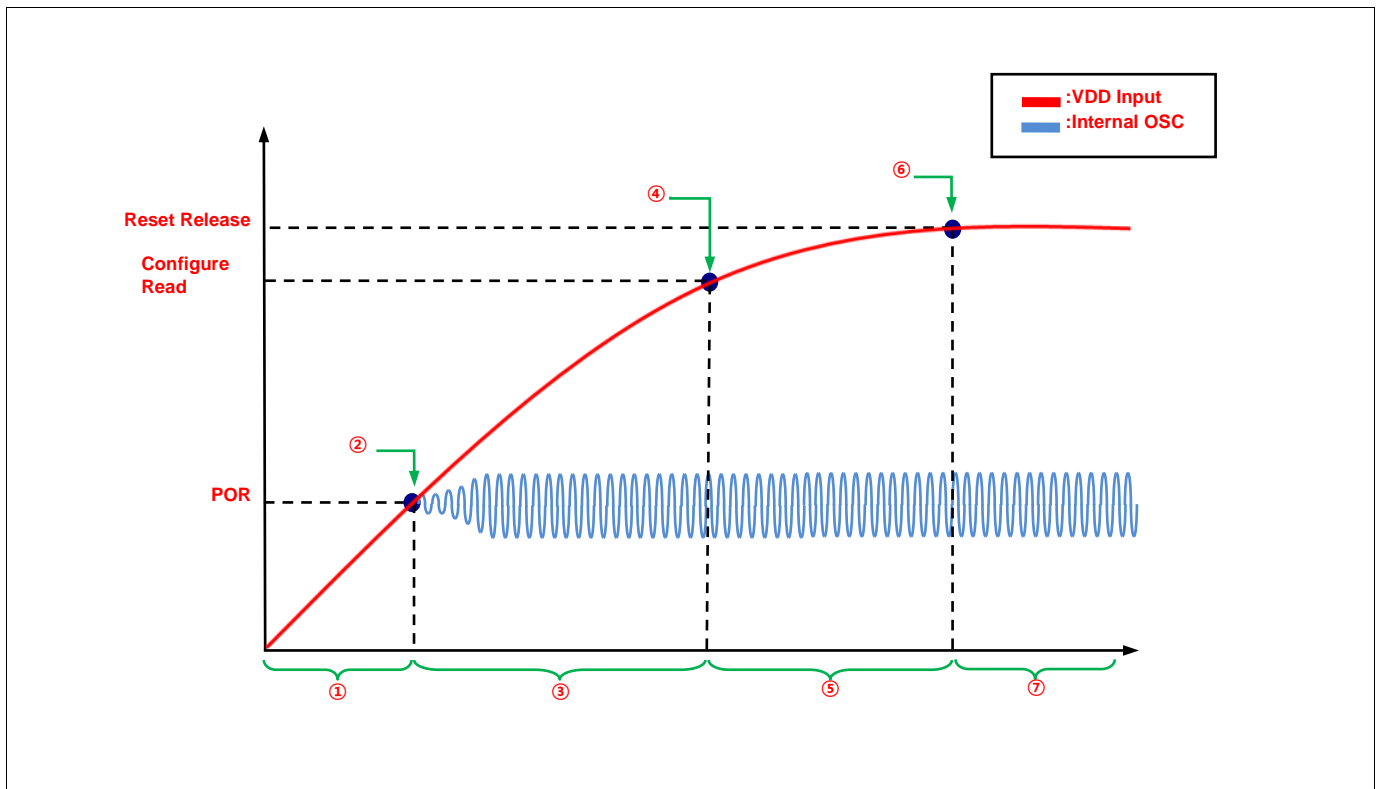

Figure 13-6. Boot Process Waveform

Process	Description	Remarks
①	-No Operation	
②	-1st POR level Detection	-about 1.4V
③	- (INT-OSC 8MHz/8)x256x28h Delay section (=10ms) -VDD input voltage must rise over than flash operating voltage for Configure option read	-Slew Rate \geq 0.15V/ms
④	- Configure option read point	-about 1.5V ~ 1.6V -Configure Value is determined by Writing Option
⑤	- Rising section to Reset Release Level	-16ms point after POR or Ext_reset release
⑥	- Reset Release section (BIT overflow) i) after 16ms, after External Reset Release (External reset) ii) 16ms point after POR (POR only)	- BIT is used for Peripheral stability
⑦	-Normal operation	

Table 13-2. Boot Process Description

13.6 External RESETB Input

The External RESETB is the input to a Schmitt trigger. If RESETB pin is held with low for at least 10us over within the operating voltage range and stable oscillation, it is applied and the internal state is initialized. After reset state becomes '1', it needs the stabilization time with 16ms and after the stable state, the internal RESET becomes '1'. The Reset process step needs 5 oscillator clocks. And the program execution starts at the vector address stored at address 0000H.

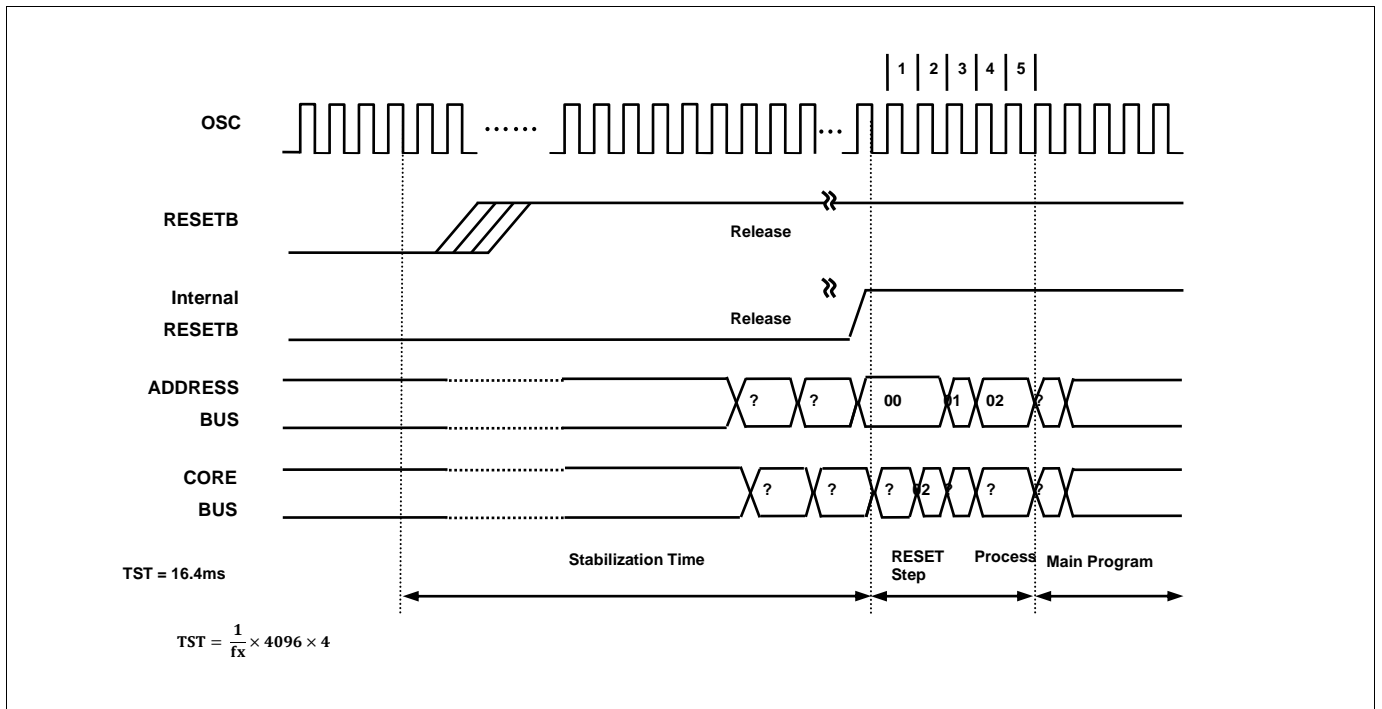

Figure 13-7. Timing Diagram after RESET

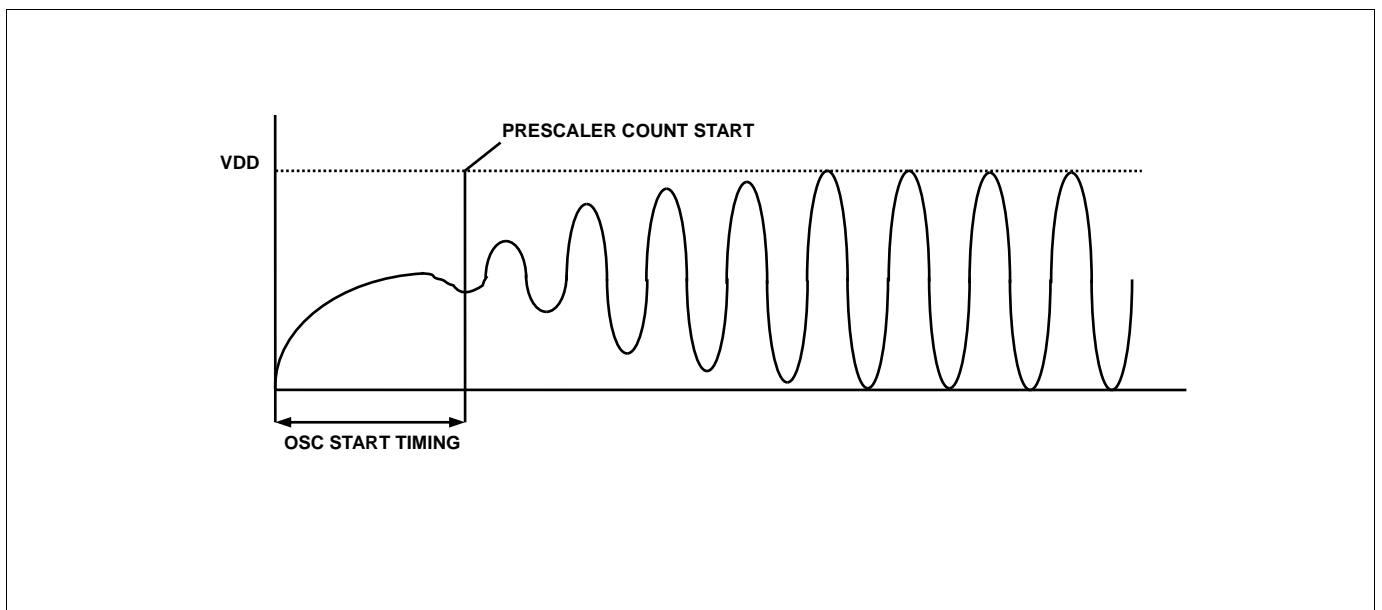

Figure 13-8. Oscillator generating waveform example

NOTE)

1. As shown Figure 13.8, the stable generating time is not included in the start-up time.
2. The RESETB pin has a Pull-up register by H/W.

13.7 Brown Out Detector Processor

The MC96F6632S has an On-chip brown-out detection circuit (BOD) for monitoring the VDD level during operation by comparing it to a fixed trigger level. The trigger level for the BOD can be selected by LVRVS[3:0] bit to be 1.60V, 2.00V, 2.10V, 2.20V, 2.32V, 2.44V, 2.59V, 2.75V, 2.93V, 3.14V, 3.38V, 3.67V, 4.00V, 4.40V. In the STOP mode, this will contribute significantly to the total current consumption. So to minimize the current consumption, the LVREN bit is set to off by software.

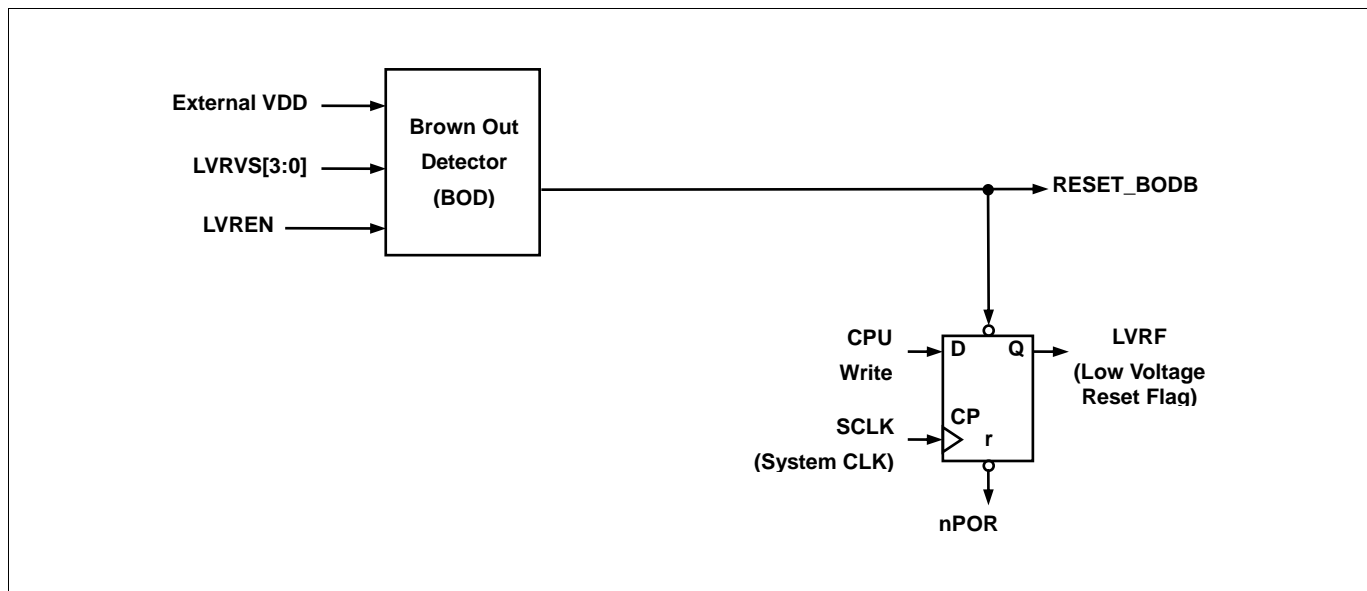

Figure 13-9. Block Diagram of BOD

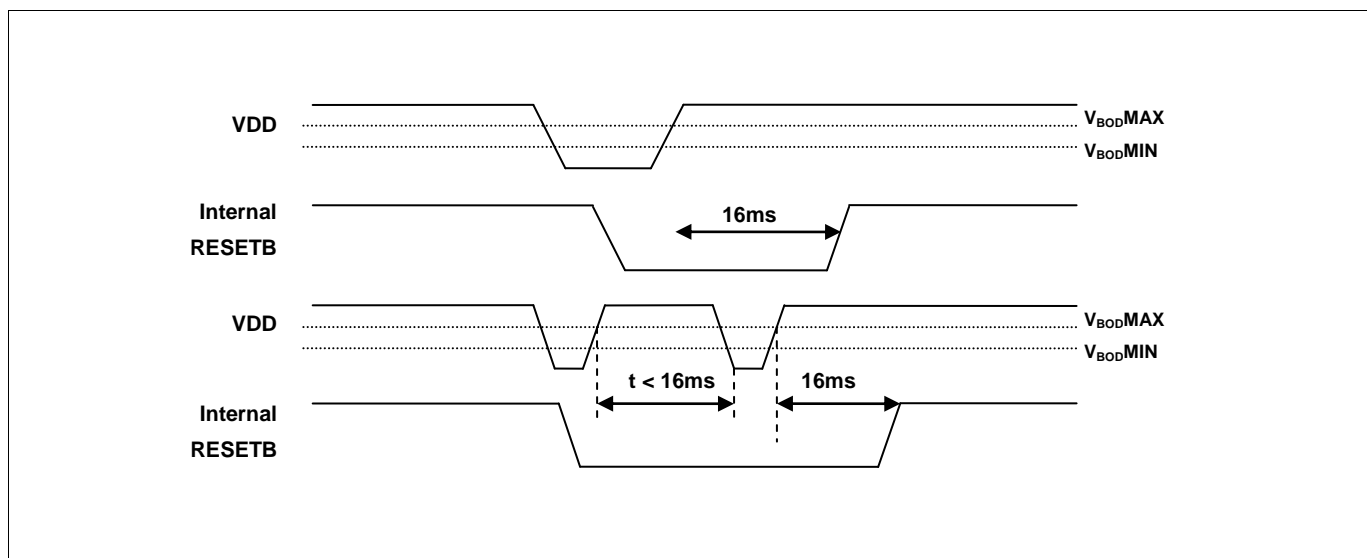

Figure 13-10. Internal Reset at the power fail situation

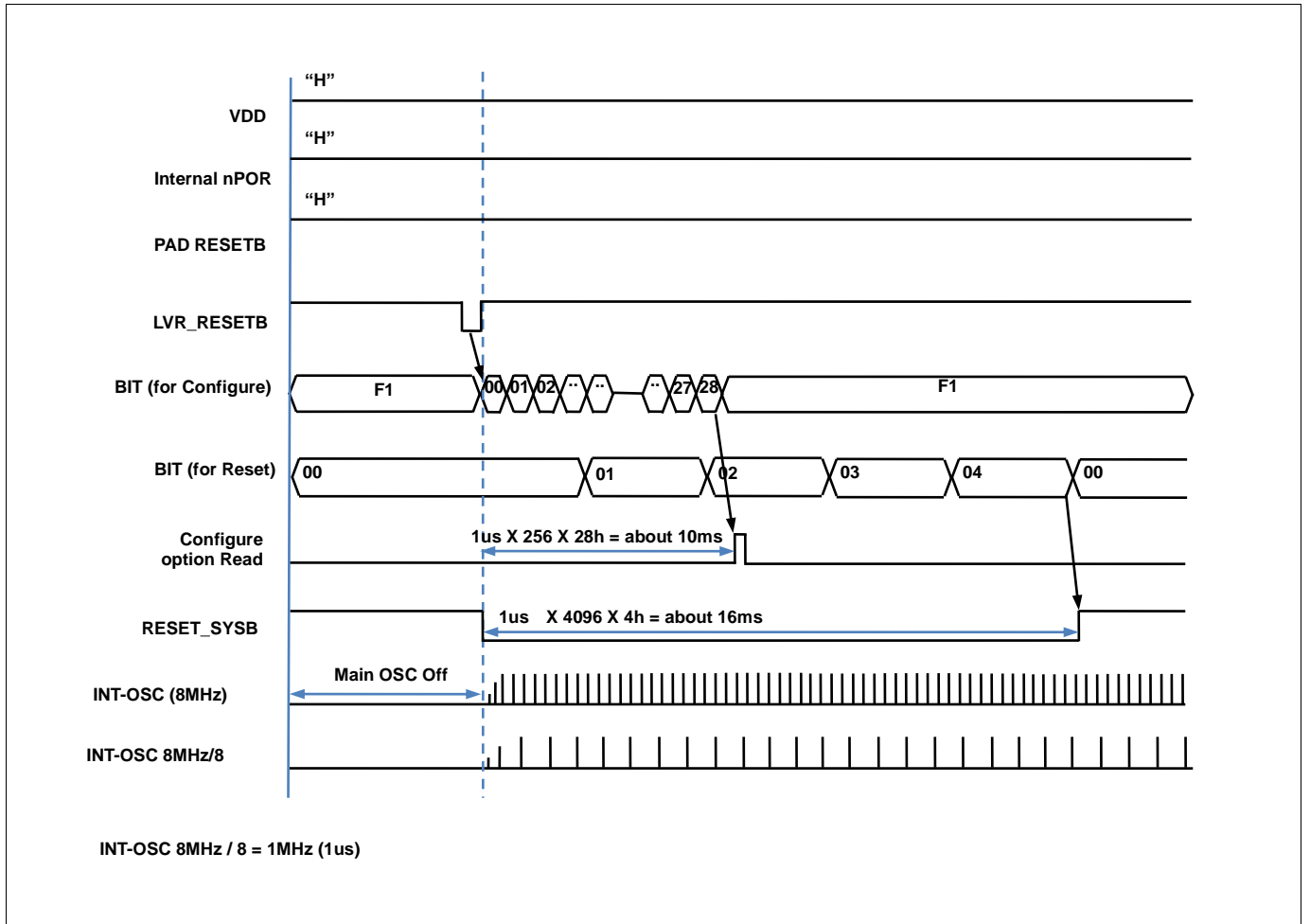

Figure 13-11. Configuration timing when BOD RESET

13.8 LVI Block Diagram

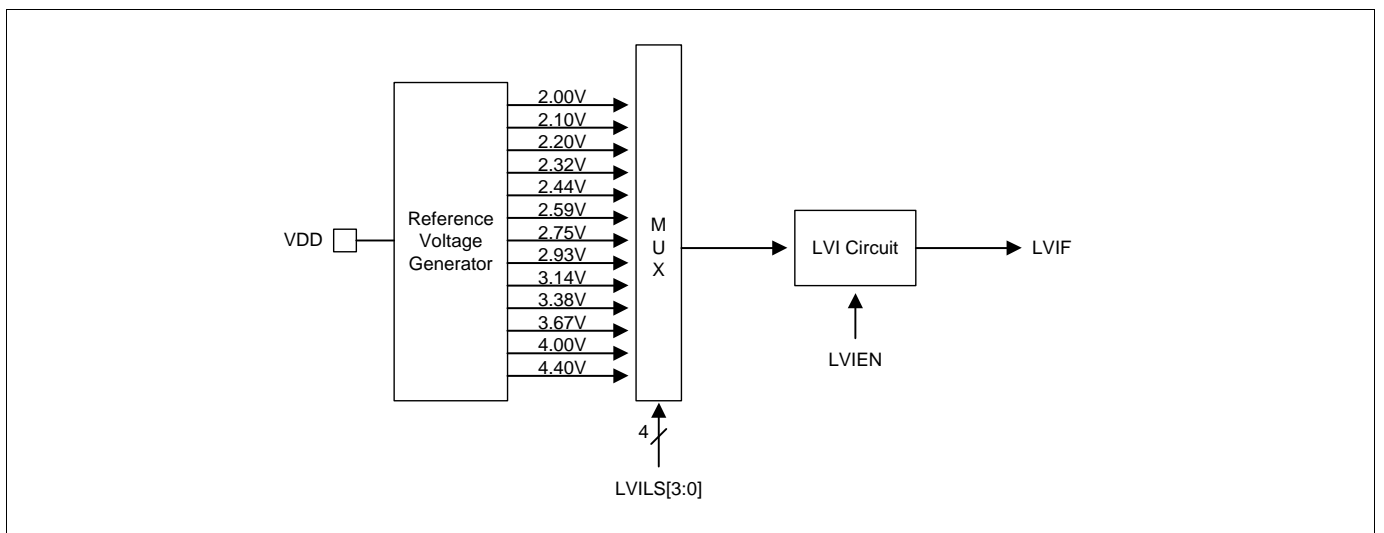

Figure 13-12. LVI Diagram

13.9 Register Map

Name	Address	Dir	Default	Description
RSTFR	86H	R/W	88H	Reset Flag Register
LVRCCR	F7H	R/W	00H	Low Voltage Reset Control Register
LVICR	E1H	R/W	00H	Low Voltage Indicator Control Register

Table 13-3. Reset Operation Register Map

13.10 Reset Operation Register Description

The reset control register consists of the reset flag register (RSTFR), low voltage reset control register (LVRCCR), and low voltage indicator control register (LVICR).

13.11 Register Description for Reset Operation

RSTFR (Reset Flag Register) : 86H

7	6	5	4	3	2	1	0
PORF	EXTRF	WDTRF	–	LVRF	–	–	–
RW	RW	RW	–	RW	–	–	–

Initial value : 88H

- PORF** Power-On Reset flag bit. The bit is reset by writing '0' to this bit.
 - 0 No detection
 - 1 Detection
- EXTRF** External Reset (RESETB) flag bit. The bit is reset by writing '0' to this bit or by Power-On Reset.
 - 0 No detection
 - 1 Detection
- WDTRF** Watch Dog Reset flag bit. The bit is reset by writing '0' to this bit or by Power-On Reset.
 - 0 No detection
 - 1 Detection
- LVRF** Low Voltage Reset flag bit. The bit is reset by writing '0' to this bit or by Power-On Reset.
 - 0 No detection
 - 1 Detection

NOTE)

- When the Power-On Reset occurs, the PORF and LVRF bits are only set to "1", the WDTRF flag bit is cleared to "0".
- When the Power-On Reset occurs, the EXTRF bit is unknown, At that time, the EXTRF bit can be set to "1" when External Reset (RESETB) occurs.
- When a reset except the POR occurs, the corresponding flag bit is only set to "1", the other flag bits are kept in the previous values.

LVRCR (Low Voltage Reset Control Register) : F7H

7	6	5	4	3	2	1	0
LVRST	–	–	LVRVS3	LVRVS2	LVRVS1	LVRVS0	LVREN
RW	–	–	RW	RW	RW	RW	RW

Initial value : 00H

LVRST LVR Enable when Stop Release
 0 Not effect at stop release
 1 LVR enable at stop release

NOTE)

- When this bit is '1', the LVREN bit is cleared to '0' by stop mode release. (LVR enable)
- When this bit is '0', the LVREN bit is not effect by stop mode release.

LVRVS[3:0] LVR Voltage Select

LVRVS3	LVRVS2	LVRVS1	LVRVS0	Description
0	0	0	0	1.60V
0	0	0	1	2.00V
0	0	1	0	2.10V
0	0	1	1	2.20V
0	1	0	0	2.32V
0	1	0	1	2.44V
0	1	1	0	2.59V
0	1	1	1	2.75V
1	0	0	0	2.93V
1	0	0	1	3.14V
1	0	1	0	3.38V
1	0	1	1	3.67V
1	1	0	0	4.00V
1	1	0	1	4.40V
1	1	1	0	Not available
1	1	1	1	Not available

LVREN LVR Operation
 0 LVR Enable
 1 LVR Disable

NOTE)

- The LVRST, LVRVS[3:0] bits are cleared by a power-on reset but are retained by other reset signals.
- The LVRVS[3:0] bits should be set to '0000b' while LVREN bit is "1".

LVICR (Low Voltage Indicator Control Register) : E1H

7	6	5	4	3	2	1	0
-	-	LVIF	LVIEN	LVILS3	LVILS2	LVILS1	LVILS0
-	-	RW	RW	RW	RW	RW	RW

Initial value : 00H

LVIF Low Voltage Indicator Flag Bit

0 No detection

1 Detection

LVIEN LVI Enable/Disable

0 Disable

1 Enable

LVILS[3:0] LVI Level Select

LVILS3	LVILS2	LVILS1	LVILS0	Description
0	0	0	0	2.00V
0	0	0	1	2.10V
0	0	1	0	2.20V
0	0	1	1	2.32V
0	1	0	0	2.44V
0	1	0	1	2.59V
0	1	1	0	2.75V
0	1	1	1	2.93V
1	0	0	0	3.14V
1	0	0	1	3.38V
1	0	1	0	3.67V
1	0	1	1	4.00V
1	1	0	0	4.40V
1	1	0	1	Not available
1	1	1	0	Not available
1	1	1	1	Not available

14 On-chip Debug System(MC96F6832 ONLY)

14.1 Overview

14.1.1 Description

MC96F6632S can not use On-chip debug(OCD). MC96F6632S isn't equipped with on-chip debugger. We recommend to develop and debug program with MC96F6832. On-chip debug system (OCD) of MC96F6832 can be used for programming the non-volatile memories and on-chip debugging. Detail descriptions for programming via the OCD interface can be found in the following chapter.

Figure 14.1 shows a block diagram of the OCD interface and the On-chip Debug system.

14.1.2 Feature

- Two-wire external interface: 1-wire serial clock input, 1-wire bi-directional serial data bus
- Debugger Access to:
 - All Internal Peripheral Units
 - Internal data RAM
 - Program Counter
 - Flash and Data EEPROM Memories
- Extensive On-chip Debug Support for Break Conditions, Including
 - Break Instruction
 - Single Step Break
 - Program Memory Break Points on Single Address
 - Programming of Flash, EEPROM, Fuses, and Lock Bits through the two-wire Interface
 - On-chip Debugging Supported by Dr.Choice®
- Operating frequency
 - Supports the maximum frequency of the target MCU

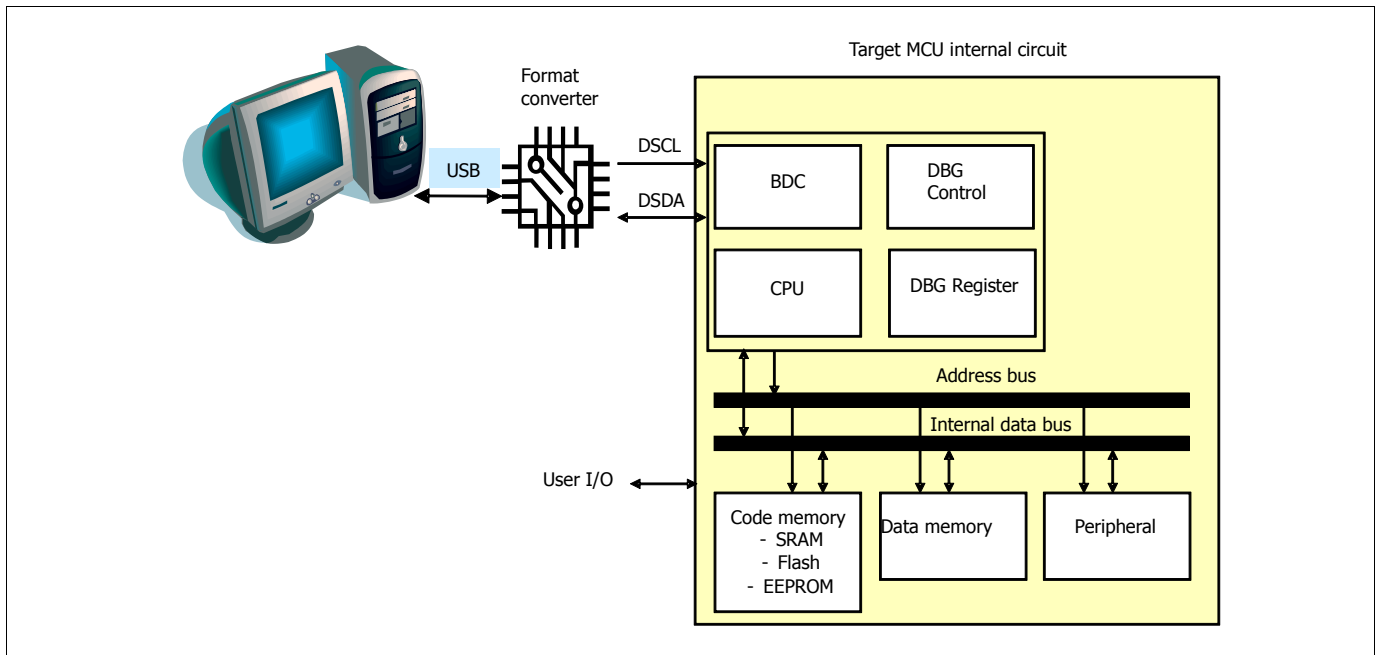

Figure 14-1. Block Diagram of On-Chip Debug System

14.2 Two-Pin External Interface

14.2.1 Basic Transmission Packet

- 10-bit packet transmission using two-pin interface.
- 1-packet consists of 8-bit data, 1-bit parity and 1-bit acknowledge.
- Parity is even of '1' for 8-bit data in transmitter.
- Receiver generates acknowledge bit as '0' when transmission for 8-bit data and its parity has no error.
- When transmitter has no acknowledge (Acknowledge bit is '1' at tenth clock), error process is executed in transmitter.
- When acknowledge error is generated, host PC makes stop condition and transmits command which has error again.
- Background debugger command is composed of a bundle of packet.
- Start condition and stop condition notify the start and the stop of background debugger command respectively.

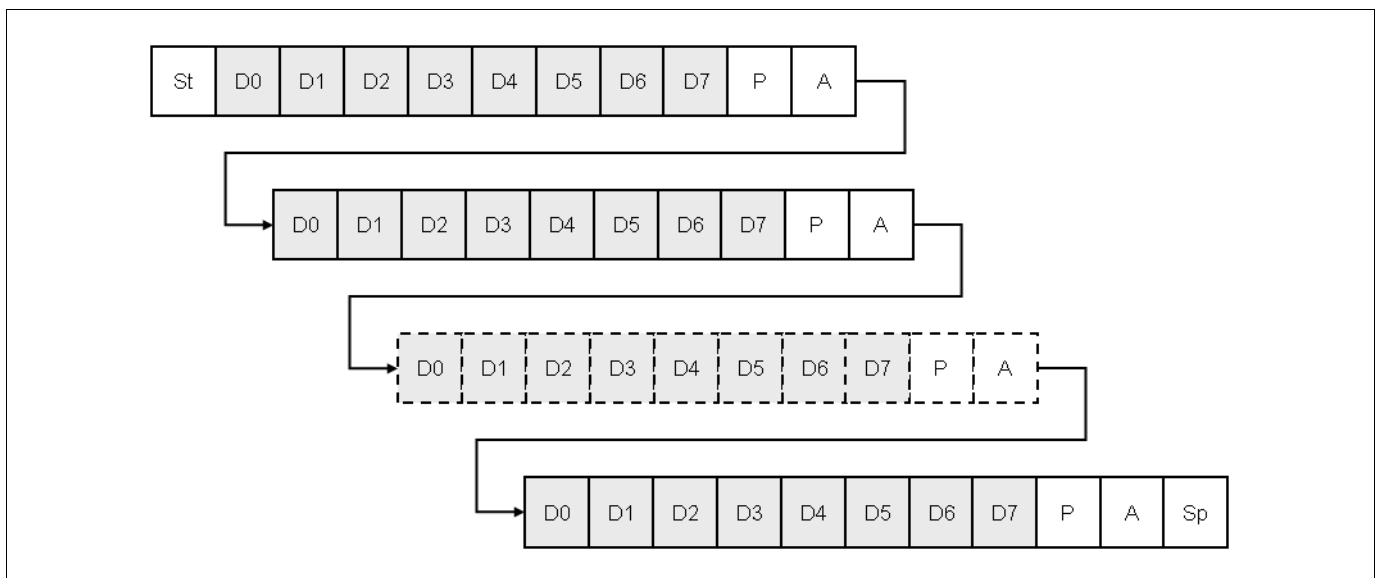

Figure 14-2. 10-bit Transmission Packet

14.2.2 Packet Transmission Timing

14.2.2.1 Data Transfer

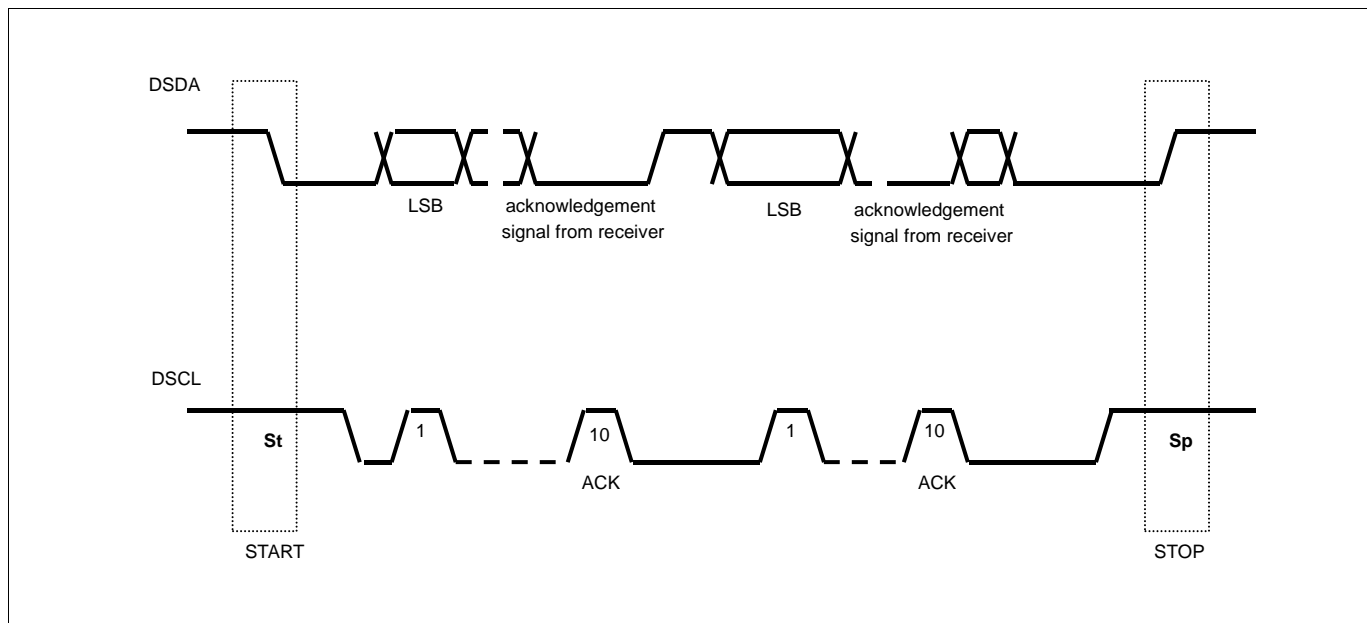

Figure 14-3. Data Transfer on the Twin Bus

14.2.2.2 Bit Transfer

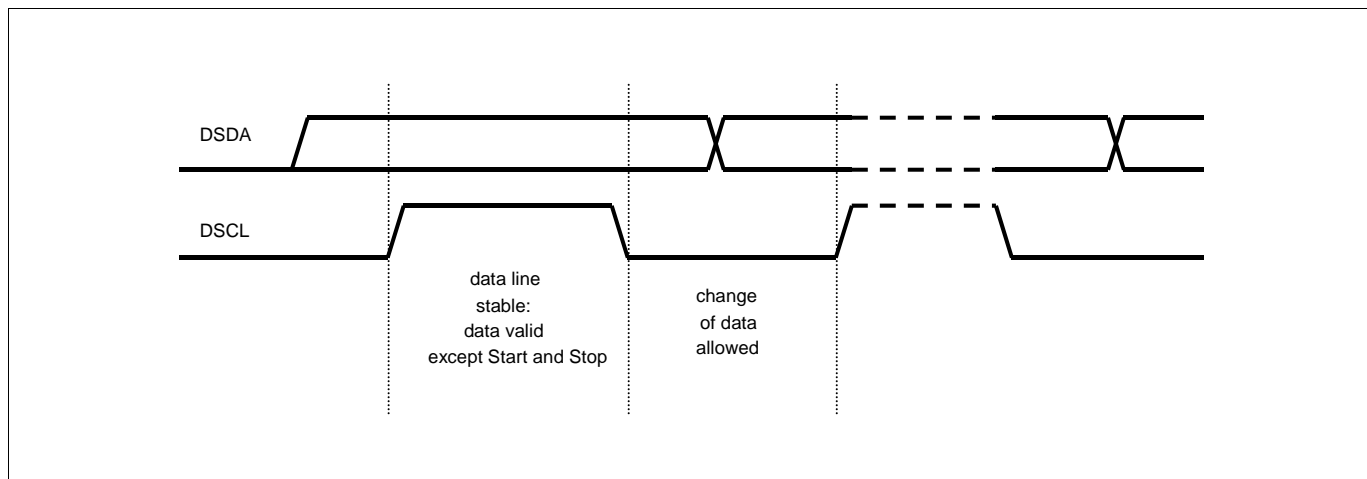

Figure 14-4. Bit Transfer on the Serial Bus

14.2.2.3 Start and Stop Condition

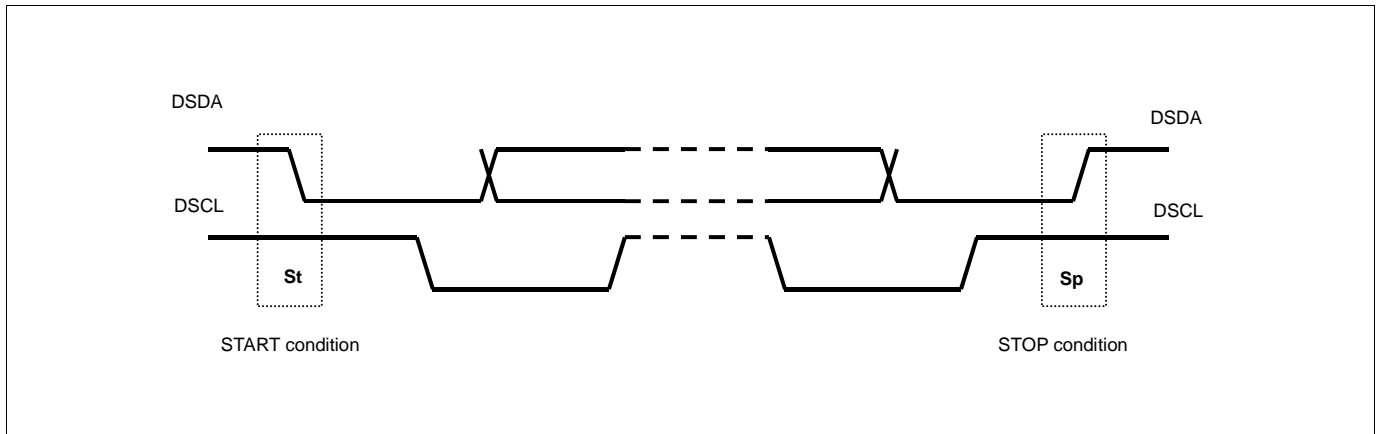

Figure 14-5. Start and Stop Condition

14.2.2.4 Acknowledge Bit

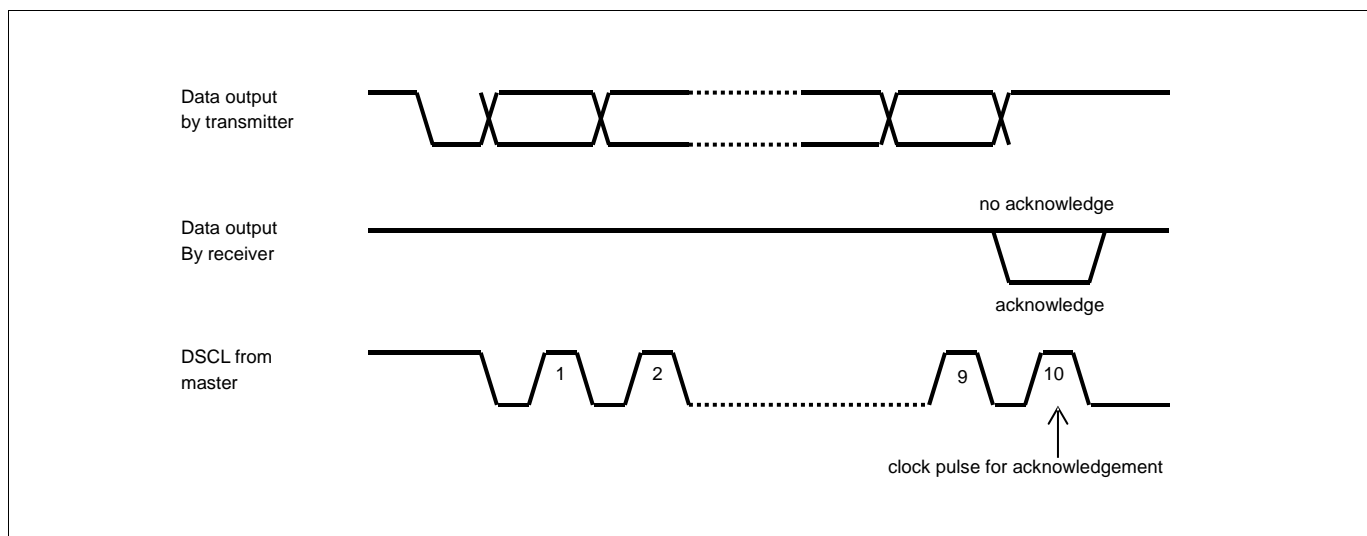

Figure 14-6. Acknowledge on the Serial Bus

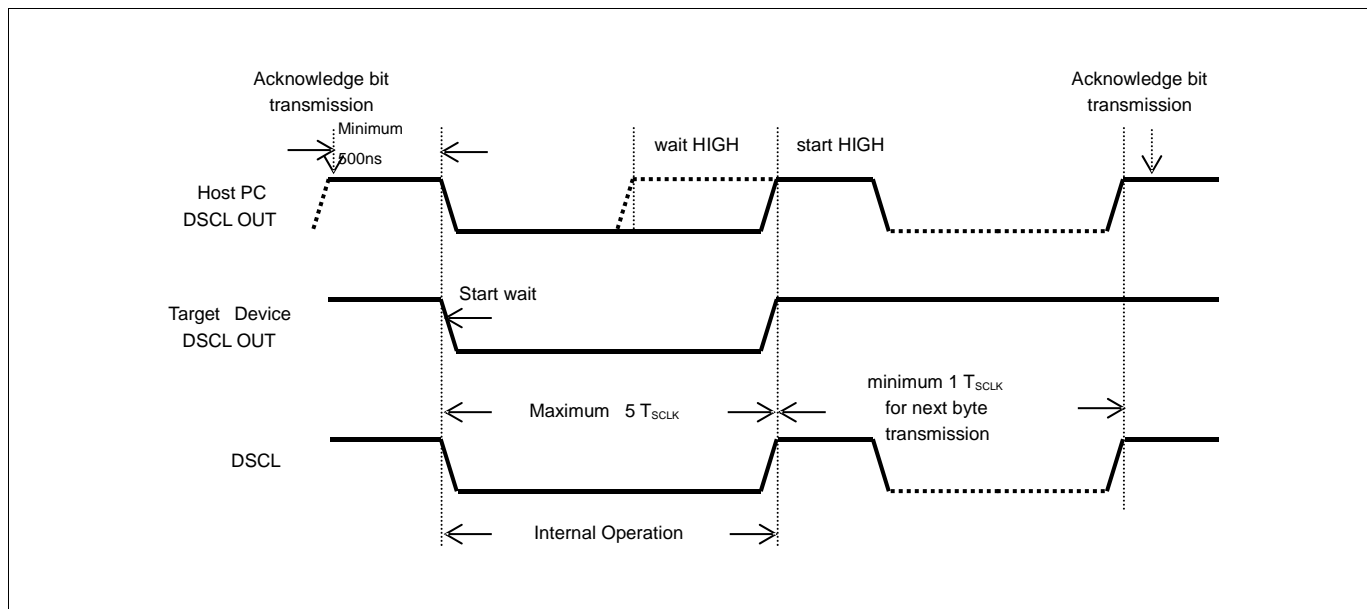

Figure 14-7. Clock Synchronization during Wait Procedure

14.2.3 Connection of Transmission

Two-pin interface connection uses open-drain (wire-AND bidirectional I/O).

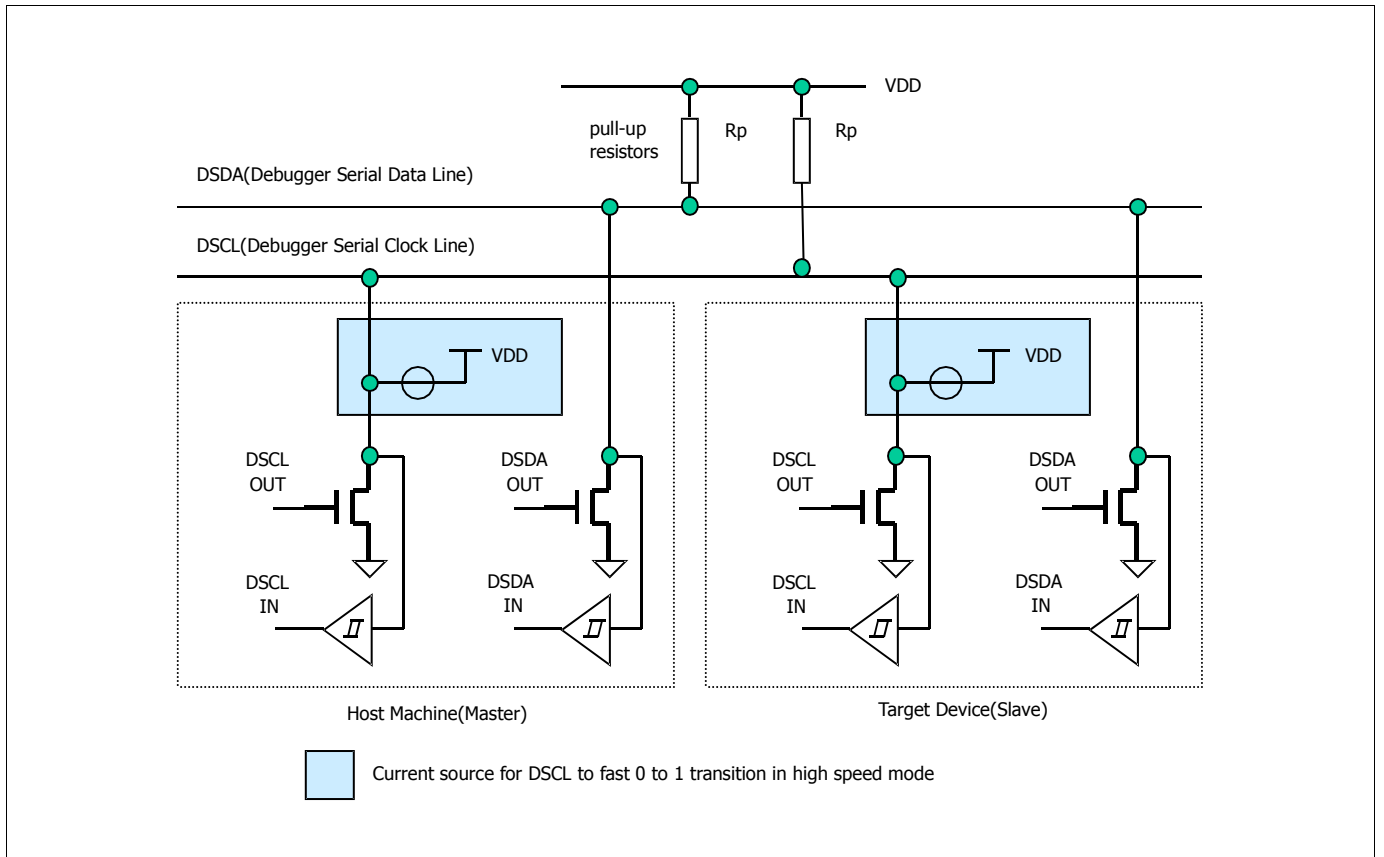

Figure 14-8. Connection of Transmission

15 Flash Memory

15.1 Overview

15.1.1 Description

MC96F6632S incorporates flash memory to which a program can be written, erased, and overwritten while mounted on the board. The flash memory can be read by 'MOVC' instruction and it can be programmed in OCD, serial ISP mode or user program mode.

- Flash Size : 32Kbytes
- Single power supply program and erase
- Command interface for fast program and erase operation
- Up to 10,000(Sector 0~507)/100,000(Sector 508~511) program/erase cycles at typical voltage and temperature for flash memory

15.1.2 Flash Program ROM Structure

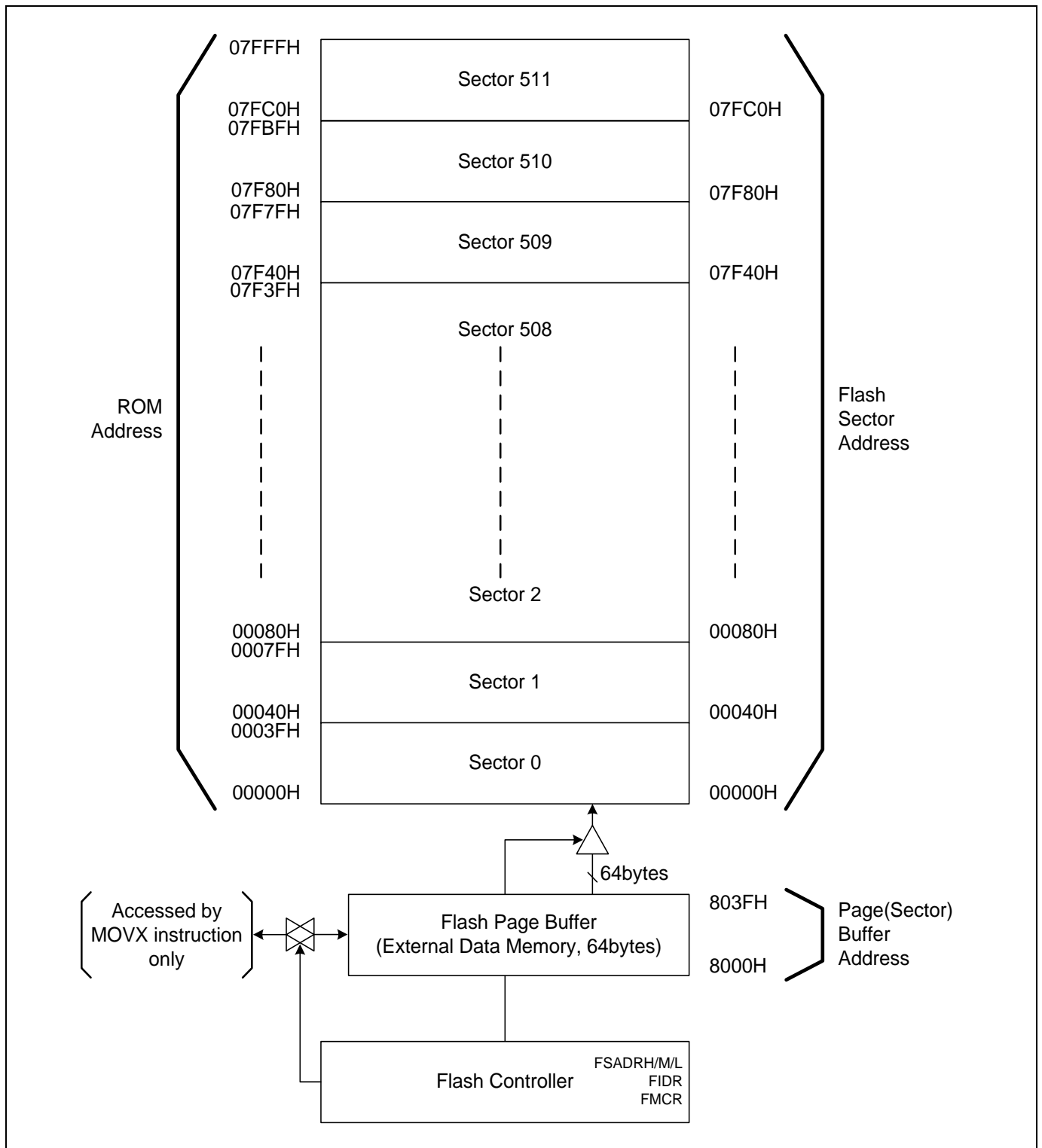

Figure 15-1. Flash Program ROM Structure

15.1.3 Register Map

Name	Address	Dir	Default	Description
FSADRH	FAH	R/W	00H	Flash Sector Address High Register
FSADRM	FBH	R/W	00H	Flash Sector Address Middle Register
FSADRL	FCH	R/W	00H	Flash Sector Address Low Register
FIDR	FDH	R/W	00H	Flash Identification Register
FMCR	FEH	R/W	00H	Flash Mode Control Register

Table 15-1. Flash Memory Register Map

15.1.4 Register Description for Flash Memory Control and Status

Flash control register consists of the flash sector address high register (FSADRH), flash sector address middle register (FSADRM), flash sector address low register (FSADRL), flash identification register (FIDR), and flash mode control register (FMCR). They are mapped to SFR area and can be accessed only in programming mode.

15.1.5 Register Description for Flash

FSADRH (Flash Sector Address High Register) : FAH

7	6	5	4	3	2	1	0
–	–	–	–	FSADRH3	FSADRH2	FSADRH1	FSADRH0
–	–	–	–	RW	RW	RW	RW

Initial value : 00H

FSADRH[3:0] Flash Sector Address High

FSADRM (Flash Sector Address Middle Register) : FBH

7	6	5	4	3	2	1	0
FSADRM7	FSADRM6	FSADRM5	FSADRM4	FSADRM3	FSADRM2	FSADRM1	FSADRM0
RW	RW	RW	RW	RW	RW	RW	RW

Initial value : 00H

FSADRM[7:0] Flash Sector Address Middle

FSADRL (Flash Sector Address Low Register) : FCH

7	6	5	4	3	2	1	0
FSADRL7	FSADRL6	FSADRL5	FSADRL4	FSADRL3	FSADRL2	FSADRL1	FSADRL0
RW	RW	RW	RW	RW	RW	RW	RW

Initial value : 00H

FSADRL[7:0] Flash Sector Address Low

FIDR (Flash Identification Register) : FDH

7	6	5	4	3	2	1	0
FIDR7	FIDR6	FIDR5	FIDR4	FIDR3	FIDR2	FIDR1	FIDR0
RW	RW	RW	RW	RW	RW	RW	RW

Initial value : 00H

FIDR[7:0] Flash Identification

Others No identification value

10100101 Identification value for a flash mode

(These bits are automatically cleared to logic '00H' immediately after one time operation)

FMCR (Flash Mode Control Register) : FEH

7	6	5	4	3	2	1	0
FMBUSY	-	-	-	-	FMCR2	FMCR1	FMCR0
R	-	-	-	-	RW	RW	RW

Initial value : 00H

FMBUSY Flash Mode Busy Bit. This bit will be used for only debugger.

0 No effect when "1" is written

1 Busy

FMCR[2:0] Flash Mode Control Bits. During a flash mode operation, the CPU is hold and the global interrupt is on disable state regardless of the IE.7 (EA) bit.

FMCR2	FMCR1	FMCR0	Description
0	0	1	Select flash page buffer reset mode and start regardless of the FIDR value (Clear all 64bytes to '0')
0	1	0	Select flash sector erase mode and start operation when the FIDR="10100101b'
0	1	1	Select flash sector write mode and start operation when the FIDR="10100101b'
1	0	0	Select flash sector hard lock and start operation when the FIDR="10100101b'

Others Values: No operation

(These bits are automatically cleared to logic '00H' immediately after one time operation)

15.1.6 Serial In-System Program (ISP) Mode

Serial in-system program uses the interface of debugger which uses two wires. Refer to chapter 14 in details about debugger

15.1.7 Protection Area (User program mode)

MC96F6632S can program its own flash memory (protection area). The protection area can not be erased or programmed. The protection areas are available only when the PAEN bit is cleared to '0', that is, enable protection area at the configure option 2 if it is needed. If the protection area isn't enabled (PAEN = '1'), this area can be used as a normal program memory.

The size of protection area can be varied by setting of configure option 2.

Protection Area Size Select		Size of Protection Area	Address of Protection Area
PASS1	PASS0		
0	0	3.8Kbytes	0100H – 0FFFH
0	1	1.7Kbytes	0100H – 07FFH
1	0	768Kbytes	0100H – 03FFH
1	1	256Kbytes	0100H – 01FFH

Table 15-2. Protection Area size

NOTE)

1. Refer to chapter 16 in configure option control.

15.1.8 Erase Mode

The sector erase program procedure in user program mode

1. Page buffer clear (FMCR=0x01)
2. Write '0' to page buffer
3. Set flash sector address register (FSADRH/FSADRM/FSADRL).
4. Set flash identification register (FIDR).
5. Set flash mode control register (FMCR).
6. Erase verify

Program Tip – sector erase

```

MOV    FMCR, #0x01    ;page buffer clear
NOP    ;Dummy instruction, This instruction must be needed.
NOP    ;Dummy instruction, This instruction must be needed.
NOP    ;Dummy instruction, This instruction must be needed.

MOV    A, #0
MOV    R0, #64        ;Sector size is 64bytes
MOV    DPH, #0x80
MOV    DPL, #0

Pgbuf_clr:
MOVX   @DPTR, A
INC    DPTR
DJNZ   R0, Pgbuf_clr ;Write '0' to all page buffer

MOV    FSADRH, #0x00
MOV    FSADRM, #0x7F
MOV    FSADRL, #0x40 ;Select sector 509
MOV    FIDR, #0xA5   ;Identification value
MOV    FMCR, #0x02   ;Start flash erase mode
NOP    ;Dummy instruction, This instruction must be needed.
NOP    ;Dummy instruction, This instruction must be needed.
NOP    ;Dummy instruction, This instruction must be needed.

MOV    A, #0         ;erase verify
MOV    R0, #64       ;Sector size is 64bytes
MOV    R1, #0
MOV    DPH, #0x7F
MOV    DPL, #0x40

Erase_verify:
MOVC   A, @A+DPTR
SUBB   A, R1
JNZ    Verify_error
INC    DPTR
DJNZ   R0, Erase_verify

Verify_error:

```

15.1.9 Write Mode

The sector Write program procedure in user program mode

1. Page buffer clear (FMCR=0x01)
2. Write data to page buffer
3. Set flash sector address register (FSADRH/FSADRM/FSADRL).
4. Set flash identification register (FIDR).
5. Set flash mode control register (FMCR).
6. Erase verify

Program Tip – sector write

```

MOV     FMCR, #0x01      ;page buffer clear
NOP     ;Dummy instruction, This instruction must be needed.
NOP     ;Dummy instruction, This instruction must be needed.
NOP     ;Dummy instruction, This instruction must be needed.

MOV     A, #0
MOV     R0, #64          ;Sector size is 64bytes
MOV     DPH, #0x80
MOV     DPL, #0

Pgbuf_WR:
MOVX    @DPTR, A
INC     A
INC     DPTR
DJNZ    R0, Pgbuf_WR    ;Write data to all page buffer

MOV     FSADRH, #0x00
MOV     FSADRM, #0x7F
MOV     FSADRL, #0x40   ;Select sector 509
MOV     FIDR, #0xA5    ;Identification value
MOV     FMCR, #0x03    ;Start flash write mode
NOP     ;Dummy instruction, This instruction must be needed.
NOP     ;Dummy instruction, This instruction must be needed.
NOP     ;Dummy instruction, This instruction must be needed.

MOV     A, #0           ;write verify
MOV     R0, #64        ;Sector size is 64bytes
MOV     R1, #0
MOV     DPH, #0x7F
MOV     DPL, #0x40

Write_verify:
MOVC   A, @A+DPTR
SUBB   A, R1
JNZ    Verify_error
INC    R1
INC    DPTR
DJNZ   R0, Write_verify

Verify_error:

```

The Byte Write program procedure in user program mode

1. Page buffer clear (FMCR=0x01)
2. Write data to page buffer
3. Set flash sector address register (FSADRH/FSADRM/FSADRL).
4. Set flash identification register (FIDR).
5. Set flash mode control register (FMCR).
6. Erase verify

Program Tip – byte write

```

MOV    FMCR, #0x01      ;page buffer clear
NOP    ;Dummy instruction, This instruction must be needed.
NOP    ;Dummy instruction, This instruction must be needed.
NOP    ;Dummy instruction, This instruction must be needed.

MOV    A, #5
MOV    DPH, #0x80
MOV    DPL, #0
MOVX   @DPTR, A         ;Write data to page buffer

MOV    A, #6
MOV    DPH, #0x80
MOV    DPL, #0x05
MOVX   @DPTR, A         ;Write data to page buffer

MOV    FSADRH, #0x00
MOV    FSADRM, #0x7F
MOV    FSADRL, #0x40    ;Select sector 509
MOV    FIDR, #0xA5      ;Identification value
MOV    FMCR, #0x03      ;Start flash write mode
NOP    ;Dummy instruction, This instruction must be needed.
NOP    ;Dummy instruction, This instruction must be needed.
NOP    ;Dummy instruction, This instruction must be needed.

MOV    A, #0             ;write verify
MOV    R1, #5
MOV    DPH, #0x7F
MOV    DPL, #0x40
MOVC   A, @A+DPTR
SUBB   A, R1             ;0x7F40 = 5 ?
JNZ    Verify_error

MOV    A, #0
MOV    R1, #6
MOV    DPH, #0x7F
MOV    DPL, #0x45
MOVC   A, @A+DPTR
SUBB   A, R1             ;0x7F45 = 6 ?
JNZ    Verify_error

```

```
Verify_error:
```

15.1.10 Read Mode

The Reading program procedure in user program mode

1. Load receive data from flash memory on MOVC instruction by indirectly addressing mode.

Program Tip – reading

```
MOV    A, #0
MOV    DPH, #0x7F
MOV    DPL, #0x40      ;flash memory address

MOVC   A, @A+DPTR     ;read data from flash memory
```

15.1.11 Hard Lock Mode

The Reading program procedure in user program mode

1. Set flash identification register (FIDR).
2. Set flash mode control register (FMCR).

Program Tip – reading

```
MOV    FIDR, #0xA5      ;Identification value
MOV    FMCR, #0x04      ;Start flash hard lock mode
NOP                    ;Dummy instruction, This instruction must be needed.
NOP                    ;Dummy instruction, This instruction must be needed.
NOP                    ;Dummy instruction, This instruction must be needed.
```

16 Configure Option

16.1 Configure Option Control

The data for configure option should be written in the configure option area (003EH – 003FH) by programmer (Writer tools).

CONFIGURE OPTION 1 : ROM Address 003FH

7	6	5	4	3	2	1	0
R_P	HL	–	–	–	–	–	–

Initial value : 00H

R_P	Read Protection
0	Disable “Read protection”
1	Enable “Read protection”
HL	Hard-Lock
0	Disable “Hard-lock”
1	Enable “Hard-lock”

CONFIGURE OPTION 2: ROM Address 003EH

7	6	5	4	3	2	1	0
–	–	–	–	–	PAEN	PASS1	PASS0

Initial value : 00H

PAEN	Protection Area Enable/Disable	
0	Disable Protection (Erasable by instruction)	
1	Enable Protection (Not erasable by instruction)	
PASS [1:0]	Protection Area Size Select	
PASS1	PASS0	Description
0	0	3.8 Kbytes (Address 0100H – 0FFFH)
0	1	1.7 Kbytes (Address 0100H – 07FFH)
1	0	768 bytes (Address 0100H – 03FFH)
1	1	256 bytes (Address 0100H – 01FFH)

17 APPENDIX

17.1 Instruction Table

Instructions are either 1, 2 or 3 bytes long as listed in the 'Bytes' column below.

Each instruction takes either 1, 2 or 4 machine cycles to execute as listed in the following table. 1 machine cycle comprises 2 system clock cycles.

ARITHMETIC				
Mnemonic	Description	Bytes	Cycles	Hex code
ADD A,Rn	Add register to A	1	1	28-2F
ADD A,dir	Add direct byte to A	2	1	25
ADD A,@Ri	Add indirect memory to A	1	1	26-27
ADD A,#data	Add immediate to A	2	1	24
ADDC A,Rn	Add register to A with carry	1	1	38-3F
ADDC A,dir	Add direct byte to A with carry	2	1	35
ADDC A,@Ri	Add indirect memory to A with carry	1	1	36-37
ADDC A,#data	Add immediate to A with carry	2	1	34
SUBB A,Rn	Subtract register from A with borrow	1	1	98-9F
SUBB A,dir	Subtract direct byte from A with borrow	2	1	95
SUBB A,@Ri	Subtract indirect memory from A with borrow	1	1	96-97
SUBB A,#data	Subtract immediate from A with borrow	2	1	94
INC A	Increment A	1	1	04
INC Rn	Increment register	1	1	08-0F
INC dir	Increment direct byte	2	1	05
INC @Ri	Increment indirect memory	1	1	06-07
DEC A	Decrement A	1	1	14
DEC Rn	Decrement register	1	1	18-1F
DEC dir	Decrement direct byte	2	1	15
DEC @Ri	Decrement indirect memory	1	1	16-17
INC DPTR	Increment data pointer	1	2	A3
MUL AB	Multiply A by B	1	4	A4
DIV AB	Divide A by B	1	4	84
DA A	Decimal Adjust A	1	1	D4

LOGICAL				
Mnemonic	Description	Bytes	Cycles	Hex code
ANL A,Rn	AND register to A	1	1	58-5F
ANL A,dir	AND direct byte to A	2	1	55
ANL A,@Ri	AND indirect memory to A	1	1	56-57
ANL A,#data	AND immediate to A	2	1	54
ANL dir,A	AND A to direct byte	2	1	52
ANL dir,#data	AND immediate to direct byte	3	2	53
ORL A,Rn	OR register to A	1	1	48-4F
ORL A,dir	OR direct byte to A	2	1	45
ORL A,@Ri	OR indirect memory to A	1	1	46-47
ORL A,#data	OR immediate to A	2	1	44
ORL dir,A	OR A to direct byte	2	1	42
ORL dir,#data	OR immediate to direct byte	3	2	43
XRL A,Rn	Exclusive-OR register to A	1	1	68-6F
XRL A,dir	Exclusive-OR direct byte to A	2	1	65
XRL A,@Ri	Exclusive-OR indirect memory to A	1	1	66-67
XRL A,#data	Exclusive-OR immediate to A	2	1	64
XRL dir,A	Exclusive-OR A to direct byte	2	1	62
XRL dir,#data	Exclusive-OR immediate to direct byte	3	2	63
CLR A	Clear A	1	1	E4
CPL A	Complement A	1	1	F4
SWAP A	Swap Nibbles of A	1	1	C4
RL A	Rotate A left	1	1	23
RLC A	Rotate A left through carry	1	1	33
RR A	Rotate A right	1	1	03
RRC A	Rotate A right through carry	1	1	13

DATA TRANSFER				
Mnemonic	Description	Bytes	Cycles	Hex code
MOV A,Rn	Move register to A	1	1	E8-EF
MOV A,dir	Move direct byte to A	2	1	E5
MOV A,@Ri	Move indirect memory to A	1	1	E6-E7
MOV A,#data	Move immediate to A	2	1	74
MOV Rn,A	Move A to register	1	1	F8-FF
MOV Rn,dir	Move direct byte to register	2	2	A8-AF
MOV Rn,#data	Move immediate to register	2	1	78-7F
MOV dir,A	Move A to direct byte	2	1	F5
MOV dir,Rn	Move register to direct byte	2	2	88-8F
MOV dir,dir	Move direct byte to direct byte	3	2	85
MOV dir,@Ri	Move indirect memory to direct byte	2	2	86-87
MOV dir,#data	Move immediate to direct byte	3	2	75
MOV @Ri,A	Move A to indirect memory	1	1	F6-F7
MOV @Ri,dir	Move direct byte to indirect memory	2	2	A6-A7
MOV @Ri,#data	Move immediate to indirect memory	2	1	76-77
MOV DPTR,#data	Move immediate to data pointer	3	2	90
MOVC A,@A+DPTR	Move code byte relative DPTR to A	1	2	93
MOVC A,@A+PC	Move code byte relative PC to A	1	2	83
MOVX A,@Ri	Move external data(A8) to A	1	2	E2-E3
MOVX A,@DPTR	Move external data(A16) to A	1	2	E0
MOVX @Ri,A	Move A to external data(A8)	1	2	F2-F3
MOVX @DPTR,A	Move A to external data(A16)	1	2	F0
PUSH dir	Push direct byte onto stack	2	2	C0
POP dir	Pop direct byte from stack	2	2	D0
XCH A,Rn	Exchange A and register	1	1	C8-CF
XCH A,dir	Exchange A and direct byte	2	1	C5
XCH A,@Ri	Exchange A and indirect memory	1	1	C6-C7
XCHD A,@Ri	Exchange A and indirect memory nibble	1	1	D6-D7

BOOLEAN				
Mnemonic	Description	Bytes	Cycles	Hex code
CLR C	Clear carry	1	1	C3
CLR bit	Clear direct bit	2	1	C2
SETB C	Set carry	1	1	D3
SETB bit	Set direct bit	2	1	D2
CPL C	Complement carry	1	1	B3
CPL bit	Complement direct bit	2	1	B2
ANL C,bit	AND direct bit to carry	2	2	82
ANL C,/bit	AND direct bit inverse to carry	2	2	B0
ORL C,bit	OR direct bit to carry	2	2	72
ORL C,/bit	OR direct bit inverse to carry	2	2	A0
MOV C,bit	Move direct bit to carry	2	1	A2
MOV bit,C	Move carry to direct bit	2	2	92

BRANCHING				
Mnemonic	Description	Bytes	Cycles	Hex code
ACALL addr 11	Absolute jump to subroutine	2	2	11→F1
LCALL addr 16	Long jump to subroutine	3	2	12
RET	Return from subroutine	1	2	22
RETI	Return from interrupt	1	2	32
AJMP addr 11	Absolute jump unconditional	2	2	01→E1
LJMP addr 16	Long jump unconditional	3	2	02
SJMP rel	Short jump (relative address)	2	2	80
JC rel	Jump on carry = 1	2	2	40
JNC rel	Jump on carry = 0	2	2	50
JB bit,rel	Jump on direct bit = 1	3	2	20
JNB bit,rel	Jump on direct bit = 0	3	2	30
JBC bit,rel	Jump on direct bit = 1 and clear	3	2	10
JMP @A+DPTR	Jump indirect relative DPTR	1	2	73
JZ rel	Jump on accumulator = 0	2	2	60
JNZ rel	Jump on accumulator ≠ 0	2	2	70
CJNE A,dir,rel	Compare A,direct jne relative	3	2	B5
CJNE A,#d,rel	Compare A,immediate jne relative	3	2	B4
CJNE Rn,#d,rel	Compare register, immediate jne relative	3	2	B8-BF
CJNE @Ri,#d,rel	Compare indirect, immediate jne relative	3	2	B6-B7
DJNZ Rn,rel	Decrement register, jnz relative	3	2	D8-DF
DJNZ dir,rel	Decrement direct byte, jnz relative	3	2	D5

MISCELLANEOUS				
Mnemonic	Description	Bytes	Cycles	Hex code
NOP	No operation	1	1	00

ADDITIONAL INSTRUCTIONS (selected through EO[7:4])				
Mnemonic	Description	Bytes	Cycles	Hex code
MOVC @(DPTR++),A	M8051W/M8051EW-specific instruction supporting software download into program memory	1	2	A5
TRAP	Software break command	1	1	A5

In the above table, an entry such as E8-EF indicates a continuous block of hex opcodes used for 8 different registers, the register numbers of which are defined by the lowest three bits of the corresponding code. Non-continuous blocks of codes, shown as 11→F1 (for example), are used for absolute jumps and calls, with the top 3 bits of the code being used to store the top three bits of the destination address.

The CJNE instructions use the abbreviation #d for immediate data; other instructions use #data.

Table of contents

Revision history	2
1 Overview	3
1.1 Description	3
1.2 Features.....	4
1.3 Development tools	5
1.3.1 Compiler	5
1.3.2 OCD(On-chip debugger) emulator and debugger	5
1.3.3 Programmer.....	7
1.4 MTP programming	10
1.4.1 Overview.....	10
1.4.2 On-Board programming.....	10
1.4.2.1 Circuit Design Guide.....	10
2 Block diagram	12
3 Pin assignment	13
4 Package Diagram	14
5 Pin Description.....	15
6 Port Structures	19
6.1 General Purpose I/O Port	19
6.2 External Interrupt I/O Port.....	20
7 Electrical Characteristics	21
7.1 Absolute Maximum Ratings	21
7.2 Recommended Operating Conditions	21
7.3 A/D Converter Characteristics	22
7.4 Power-On Reset Characteristics	22
7.5 Low Voltage Reset and Low Voltage Indicator Characteristics	23
7.6 Internal RC Oscillator Characteristics.....	24
7.7 Internal Watch-Dog Timer RC Oscillator Characteristics.....	24
7.8 DC Characteristics	25
7.9 Serial I/O Characteristics	27
7.10 UART Characteristics	29
7.11 Data Retention Voltage in Stop Mode	30
7.12 Internal Flash Rom Characteristics	31
7.13 Input/Output Capacitance	31
7.14 Main Clock Oscillator Characteristics	32
7.15 Sub Clock Oscillator Characteristics	33
7.16 Main Oscillation Stabilization Characteristics	34
7.17 Sub Oscillation Characteristics	35
7.18 Operating Voltage Range	36
7.19 Recommended Circuit and Layout	36
7.20 Typical Characteristics.....	37
8 Memory	40
8.1 Program Memory	40
8.2 Data Memory	42
8.3 XRAM Memory	44
8.4 SFR Map.....	45
8.4.1 SFR Map Summary.....	45
8.4.2 SFR Map	46
8.4.3 Compiler Compatible SFR.....	50
9 I/O Ports	52
9.1 I/O Ports.....	52
9.2 Port Register.....	52

9.2.1	Data Register (Px)	52
9.2.2	Direction Register (PxIO)	52
9.2.3	Pull-up Resistor Selection Register (PxPU)	52
9.2.4	Open-drain Selection Register (PxOD)	52
9.2.5	De-bounce Enable Register (PxDB).....	52
9.2.6	P9 Control and Data Register (P9CDR).....	53
9.2.7	Port Function Selection Register (PFSRx)	53
9.2.8	Register Map	54
9.3	P0 Port.....	56
9.3.1	P0 Port Description.....	56
9.3.2	Register description for P0	56
9.4	P1 Port.....	58
9.4.1	P1 Port Description.....	58
9.4.2	Register description for P1	58
9.5	P2 Port.....	60
9.5.1	P2 Port Description.....	60
9.5.2	9.5.2 Register description for P2	60
9.6	P3 Port.....	61
9.6.1	P3 Port Description.....	61
9.6.2	Register description for P3	61
9.7	P4 Port.....	62
9.7.1	P4 Port Description.....	62
9.7.2	Register description for P4	62
9.8	P5 Port.....	63
9.8.1	P5 Port Description.....	63
9.8.2	Register description for P5	63
9.9	P6 Port.....	64
9.9.1	P6 Port Description.....	64
9.9.2	Register description for P6	64
9.10	P7 Port.....	65
9.10.1	P7 Port Description.....	65
9.10.2	Register description for P7	65
9.11	P8 Port.....	66
9.11.1	P8 Port Description.....	66
9.11.2	Register description for P8	66
9.12	P9 Port.....	67
9.12.1	P9 Port Description.....	67
9.12.2	Register description for P9	67
9.13	Port Function	68
9.13.1	Port Function Description	68
9.13.2	Register description for PFSR0 ~ PFSR8	68
10	Interrupt Controller	76
10.1	Overview.....	76
10.2	External Interrupt	78
10.3	Block Diagram	79
10.4	Interrupt Vector Table.....	80
10.5	Interrupt Sequence	81
10.6	Effective Timing after Controlling Interrupt Bit	82
10.7	Multi Interrupt.....	83
10.8	Interrupt Enable Accept Timing.....	84
10.9	Interrupt Service Routine Address.....	84
10.10	Saving/Restore General-Purpose Registers.....	84
10.11	Interrupt Timing	85
10.12	Interrupt Register Overview	86
10.12.1	Interrupt Enable Register (IE, IE1, IE2, IE3).....	86
10.12.2	Interrupt Priority Register (IP, IP1)	86
10.12.3	External Interrupt Flag Register (EIFLAG0, EIFLAG1).....	86
10.12.4	External Interrupt Edge Register (EIEDGE0, EIEDGE1).....	86
10.12.5	External Interrupt Polarity Register (EIPOL0, EIPOL1).....	86
10.12.6	External Interrupt Enable Register (EIENAB0, EIENAB1).....	86

10.12.7	Register Map.....	87
10.12.8	Interrupt Register Description.....	87
10.12.9	Register Description for Interrupt.....	88
11	Peripheral Hardware	93
11.1	Clock Generator.....	93
11.1.1	Overview.....	93
11.1.2	Block Diagram	93
11.1.3	Register Map	94
11.1.4	Clock Generator Register Description.....	94
11.1.5	Register Description for Clock Generator	94
11.2	Basic Interval Timer	96
11.2.1	Overview.....	96
11.2.2	Block Diagram	96
11.2.3	Register Map	96
11.2.4	Basic Interval Timer Register Description	96
11.2.5	Register Description for Basic Interval Timer	97
11.3	Watch Dog Timer	98
11.3.1	Overview.....	98
11.3.2	WDT Interrupt Timing Waveform	98
11.3.3	Block Diagram	99
11.3.4	Register Map	99
11.3.5	Watch Dog Timer Register Description	99
11.3.6	Register Description for Watch Dog Timer	100
11.4	Watch Timer.....	101
11.4.1	Overview.....	101
11.4.2	Block Diagram	101
11.4.3	Register Map	102
11.4.4	Watch Timer Register Description	102
11.4.5	Register Description for Watch Timer.....	102
11.5	Timer 0.....	104
11.5.1	Overview.....	104
11.5.2	8-Bit Timer/Counter Mode	105
11.5.3	8-Bit PWM Mode	107
11.5.4	8-Bit Capture Mode	109
11.5.5	Block Diagram	111
11.5.6	Register Map	112
11.5.7	Timer/Counter 0 Register Description	112
11.5.8	Register Description for Timer/Counter 0	112
11.6	Timer 1.....	114
11.6.1	Overview.....	114
11.6.2	8-Bit Timer/Counter 1 Mode	115
11.6.3	8-Bit Timer 1 Carrier Frequency Mode.....	117
11.6.4	Carrier Output Pulse Width Calculations.....	118
11.6.5	Block Diagram	120
11.6.6	Register Map	120
11.6.7	Timer/Counter 1 Register Description	120
11.6.8	Register description for Timer/Counter 1.....	121
11.7	Timer 2.....	123
11.7.1	Overview.....	123
11.7.2	Block Diagram	123
11.7.3	Register Map	123
11.7.4	Timer/Counter 2 Register Description	124
11.7.5	Register Description for Timer/Counter 2.....	124
11.8	Timer 3.....	126
11.8.1	Overview.....	126
11.8.2	16-Bit Timer/Counter Mode	127
11.8.3	16-Bit PWM Mode	128
11.8.4	16-Bit Capture Mode	129
11.8.5	Block Diagram	130
11.8.6	Register Map	130

11.8.7	Timer/Counter 3 Register Description	131
11.8.8	Register Description for Timer/Counter 3	131
11.9	Buzzer Driver	134
11.9.1	Overview	134
11.9.2	Block Diagram	134
11.9.3	Register Map	135
11.9.4	Buzzer Driver Register Description	135
11.9.5	Register Description for Buzzer Driver	135
11.10	SIO	136
11.10.1	Overview	136
11.10.2	Block Diagram	136
11.10.3	SIO Pre-Scale Register (SIOPS)	137
11.10.4	The usage of SIO	137
11.10.5	SIO Timing Diagram	138
11.10.6	Register Map	139
11.10.7	SIO Register Description	139
11.10.8	Register Description for SIO	139
11.11	12-Bit A/D Converter	141
11.11.1	Overview	141
11.11.2	Conversion Timing	141
11.11.3	Block Diagram	142
11.11.4	ADC Operation	143
11.11.5	Register Map	144
11.11.6	ADC Register Description	144
11.11.7	Register Description for ADC	145
11.12	UART	148
11.12.1	Overview	148
11.12.2	Block Diagram	149
11.12.3	Clock Generation	150
11.12.4	External Clock (ACK)	150
11.12.5	Synchronous mode operation	151
11.12.6	Data format	152
11.12.7	Parity bit	153
11.12.8	UART Transmitter	153
11.12.8.1	Sending Tx data	153
11.12.8.2	Transmitter flag and interrupt	153
11.12.8.3	Parity Generator	154
11.12.8.4	Disabling Transmitter	154
11.12.9	UART Receiver	154
11.12.9.1	Receiving Rx data	154
11.12.9.2	Receiver Flag and Interrupt	155
11.12.9.3	Parity Checker	155
11.12.9.4	Disabling Receiver	155
11.12.9.5	Asynchronous Data Reception	156
11.12.10	Register Map	157
11.12.11	UART Register Description	157
11.12.12	Register Description for UART	157
11.12.13	Baud Rate setting (example)	162
11.13	LCD Driver	163
11.13.1	Overview	163
11.13.2	LCD Display RAM Organization	164
11.13.3	LCD Signal Waveform	165
11.13.4	LCD Voltage Dividing Resistor Connection	169
11.13.5	Block Diagram	170
11.13.6	Register Map	170
11.13.7	LCD Driver Register Description	170
11.13.8	Register Description for LCD Driver	171
12	Power Down Operation	173
12.1	Overview	173
12.2	Peripheral Operation in IDLE/STOP Mode	173
12.3	IDLE Mode	174

12.4	STOP Mode	175
12.5	Release Operation of STOP Mode	176
12.6	Register Map	177
12.7	Power Down Operation Register Description	177
12.8	Register Description for Power Down Operation	177
13	RESET.....	178
13.1	Overview	178
13.2	Reset Source	178
13.3	RESET Block Diagram	178
13.4	RESET Noise Canceller	179
13.5	Power On RESET	180
13.6	External RESETB Input	183
13.7	Brown Out Detector Processor	184
13.8	LVI Block Diagram	185
13.9	Register Map	186
13.10	Reset Operation Register Description	186
13.11	Register Description for Reset Operation	186
14	On-chip Debug System(MC96F6832 ONLY).....	189
14.1	Overview	189
14.1.1	Description.....	189
14.1.2	Feature	189
14.2	Two-Pin External Interface.....	191
14.2.1	Basic Transmission Packet	191
14.2.2	Packet Transmission Timing.....	192
14.2.2.1	Data Transfer.....	192
14.2.2.2	Bit Transfer	192
14.2.2.3	Start and Stop Condition.....	193
14.2.2.4	Acknowledge Bit	194
14.2.3	Connection of Transmission	195
15	Flash Memory	196
15.1	Overview	196
15.1.1	Description.....	196
15.1.2	Flash Program ROM Structure	197
15.1.3	Register Map	198
15.1.4	Register Description for Flash Memory Control and Status	198
15.1.5	Register Description for Flash	199
15.1.6	Serial In-System Program (ISP) Mode	201
15.1.7	Protection Area (User program mode)	201
15.1.8	Erase Mode	202
15.1.9	Write Mode	203
15.1.10	Read Mode	205
15.1.11	Hard Lock Mode.....	205
16	Configure Option.....	206
16.1	Configure Option Control	206
17	APPENDIX	207
17.1	Instruction Table.....	207
Table of contents.....		211