

Service
Service
Service



Service Manual



CONTENTS

Technical specification and version variation1-2

Service measurement setup.....1-3
Service aids1-4

Instructions on CD playability2-1.. 2-2

Block diagram.....3-1
Wiring diagram4-1
Disassembly diagram.....4-2..4-3

Main board and Tuner board
Circuit diagram.....5-1..5-6
Layout diagram.....5-7

Display and Key board
Circuit diagram6-1..6-2
Layout diagram.....6-3..6-4

SMPS Power board
Circuit diagram7-1
Layout diagram.....7-2..7-3

Exploded view diagram8-1



© Copyright 2010 Philips Consumer Electronics B.V. Eindhoven, The Netherlands
All rights reserved. No part of this publication may be reproduced, stored in a retrieval system or transmitted, in any form or by any means, electronic, mechanical, photocopying, or otherwise without the prior permission of Philips.



TECHNICAL SPECIFICATION

Amplifier

Rated Output Power	2 X 25 W RMS
Frequency Response	40 Hz - 20000 Hz, ±3 dB
Signal to Noise Ratio	> 65 dB
Aux Input	500 mV RMS 600 ohm

Disc

Laser Type	Semiconductor
Disc Diameter	12 cm/8 cm
Video Decoding	MPEG-1 / MPEG-2 / DivX
Video DAC	12 Bits
Signal System	PAL / NTSC
Video Format	4:3 / 16:9
Video S/N	> 48 dB
Audio DAC	24 Bits / 96 kHz
Total Harmonic Distortion	< 0.8% (1 kHz)
Frequency Response	4 Hz - 20 kHz (44.1 kHz) 4 Hz - 22 kHz (48 kHz) 4 Hz - 24 kHz (96 kHz)
S/N Ratio	> 65 dBA
Video resolution	720 X 480 X 30; 720 X 576 X 25

Tuner (FM)

Tuning Range	87.5 - 108MHz
Tuning grid	50KHz
Sensitivity - Mono, 26dB S/N Ratio	<22 dBf
Sensitivity - Stereo, 46dB S/N Ratio	<43 dBf
Search Selectivity	>28dBf
Total Harmonic Distortion	<2%
Signal to Noise Ratio	>55dB

Speakers

Speaker Impedance	6 ohm
Speaker Driver	Full range speaker
Sensitivity	> 80 dB/m/W±4dB/m/W

General information

AC power	110 - 240 V, 50/60 Hz
Operation Power Consumption	25 W
Eco Standby Power Consumption	< 1 W
Composite Video Output	1.0 Vp-p, 75 ohm
Headphone output	2 X 15 mW, 32 ohm
USB Direct	Version 2.0
Dimensions	
- Main Unit (W x H x D)	152 X 170 X 210 mm
- Speaker Box (W x H x D)	152 X 170 X 200 mm
Weight	
- With Packing	6.79 kg
- Net weight	3.16 kg

VERSION VARIATION

Type /Versions:		MCD135									
Board in used:	Service policy	/58	/51					/78	/55		
MAIN BOARD AND TUNER BOARD								M/C			
DISPLAY BOARD AND KEY BOARD								C			
SMPS POWER BOARD								C			
DVD MECH BOARD								C			
Type /Versions:		DCM105									
Features	Feature difference	/58	/51					/78	/55		
RDS & DAB											
VOLTAGE SELECTOR											
ECO STANDBY - DARK								√			
* TIPS : C -- Component Lever Repair. M -- Module Lever Repair √ -- Used											

MEASUREMENT SETUP

Tuner FM

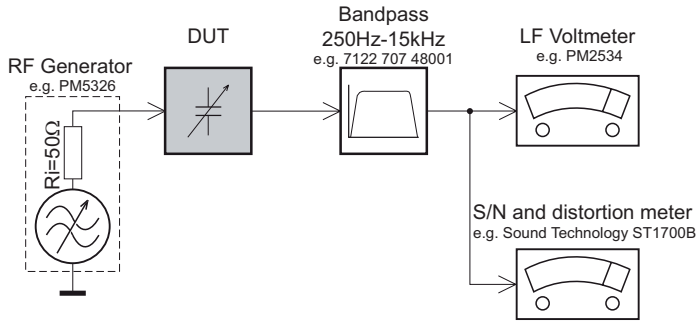

Use a bandpass filter to eliminate hum (50Hz, 100Hz) and disturbance from the pilotone (19kHz, 38kHz).

Tuner AM (MW,LW)

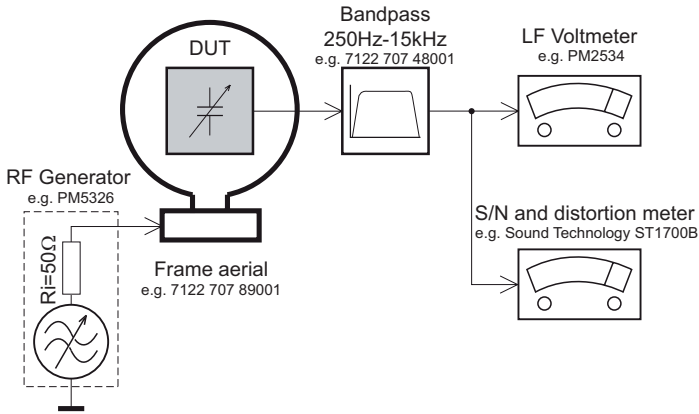

To avoid atmospheric interference all AM-measurements have to be carried out in a Faraday's cage. Use a bandpass filter (or at least a high pass filter with 250Hz) to eliminate hum (50Hz, 100Hz).

CD

Use Audio Signal Disc SBC429 4822 397 30184 (replaces test disc 3)

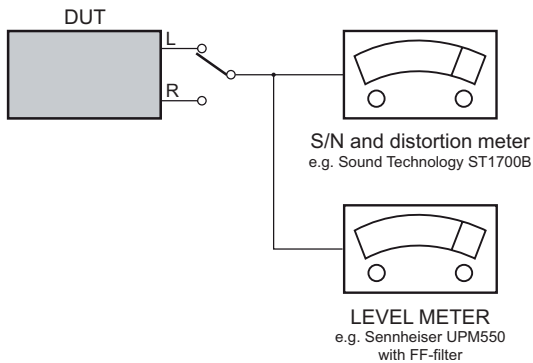

Recorder

Use Universal Test Cassette Cr02 SBC419 4822 397 30069 or Universal Test Cassette Fe SBC420 4822 397 30071

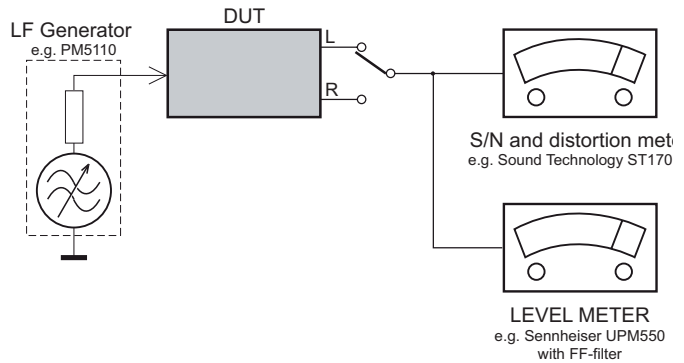

SERVICE AIDS

GB WARNING

All ICs and many other semi-conductors are susceptible to electrostatic discharges (ESD). Careless handling during repair can reduce life drastically.

When repairing, make sure that you are connected with the same potential as the mass of the set via a wrist wrap with resistance. Keep components and tools also at this potential.

ESD



GB

Safety regulations require that the set be restored to its original condition and that parts which are identical with those specified, be used

Safety components are marked by the symbol .

**CLASS 1
LASER PRODUCT**

INFORMATION ABOUT LEAD-FREE SOLDERING

Philips CE is producing lead-free sets from 1.1.2005 onwards.

IDENTIFICATION:

Regardless of special logo (not always indicated) one must treat all sets from 1 Jan 2005 onwards, according next rules:



- On our website www.atyourservice.ce.Philips.com you find more information to:
 - * BGA-de-/soldering (+ baking instructions)
 - * Heating-profiles of BGAs and other ICs used in Philips-sets
 - * Lead free

You will find this and more technical information within the "magazine", chapter "workshop news".

For additional questions please contact your local repair-helpdesk.

SERVICE INSTRUCTION

Safety regulations require that after a repair, the set must be returned in its original condition. Pay in particular attention to the following points:

- Route the wire trees correctly and fix them with the mounted cable clamps.
- Check the insulation of the AC Power lead for external damage.
- Check the strain relief of the AC Power cord for proper function.
- Check the electrical DC resistance between the AC Power Plug and the secondary side (only for sets which have a AC Power isolated power supply):
 1. Unplug the AC Power cord and connect a wire between the two pins of the AC Power plug.
 2. Set the AC Power switch to the "on" position (keep the AC Power cord unplugged!).
 3. Measure the resistance value between the pins of the AC Power plug and the metal shielding of the tuner or the aerial connection on the set. The reading should be larger than 4.5 Mohm (For U.S. it should be between 4.2 Mohm and 12 Mohm).
 4. Switch "off" the set, and remove the wire between the two pins of the AC Power plug.
- Check the cabinet for defects, to avoid touching of any inner parts by the customer.

INSTRUCTIONS ON CD PLAYABILITY

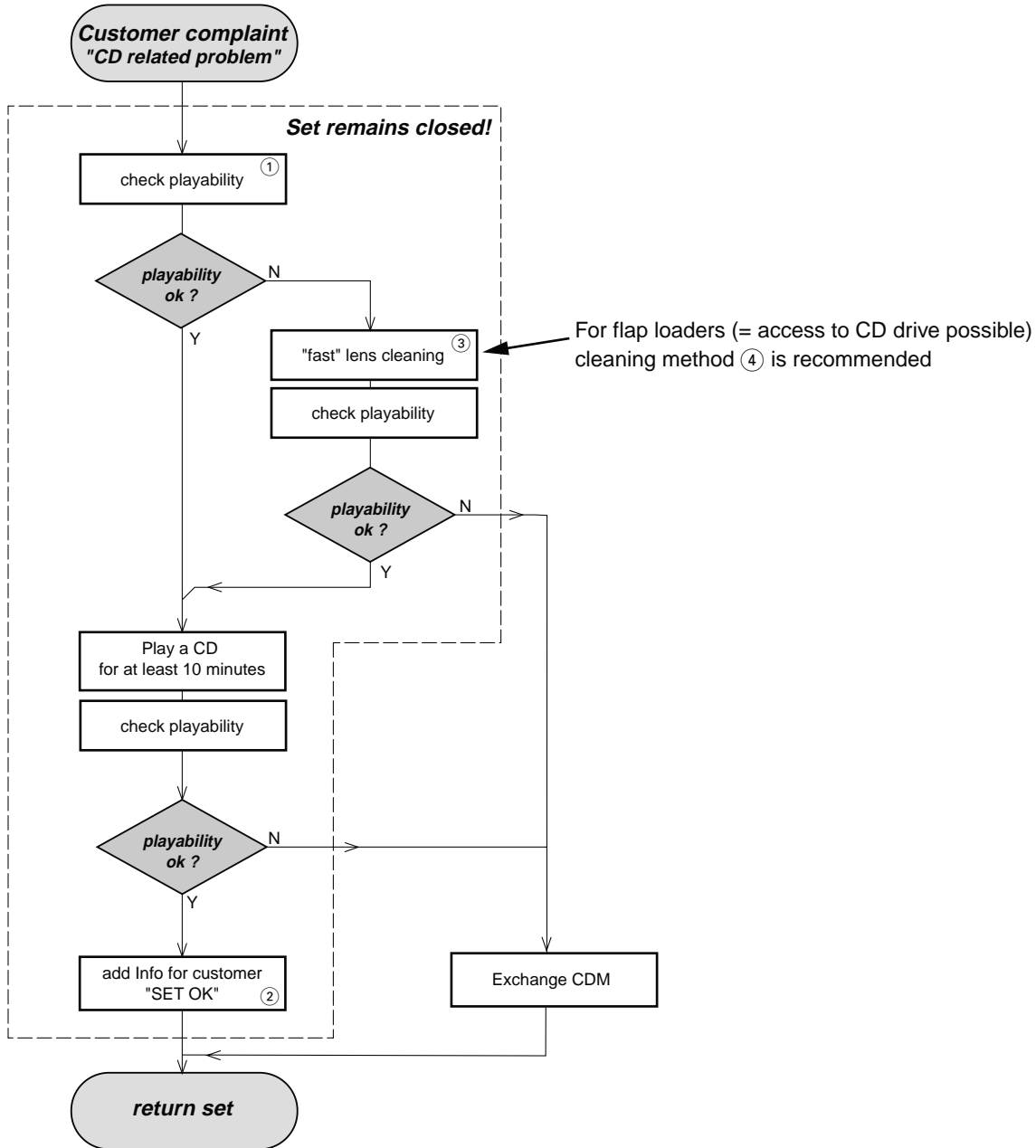

① - ④ For description - see following pages

INSTRUCTIONS ON CD PLAYABILITY

①

PLAYABILITY CHECK

For sets which are compatible with **CD-RW** discs
 use CD-RW Printed Audio Disc7104 099 96611
 TR 3 (Fingerprint)
 TR 8 (600µ Black dot) **maximum at 01:00**

- playback of these two tracks without audible disturbance
 playing time for: Fingerprint ≥ 10 seconds
 Black dot from 00:50 to 01:10
- jump forward/backward (search) within a reasonable time

For all other sets
 use CD-DA SBC 444A4822 397 30245
 TR 14 (600µ Black dot) **maximum at 01:15**
 TR 19 (Fingerprint)
 TR 10 (1000µ wedge)

- playback of all these tracks without audible disturbance
 playing time for: 1000µ wedge ≥ 10 seconds
 Fingerprint ≥ 10 seconds
 Black dot from 01:05 to 01:25
- jump forward/backward (search) within a reasonable time

②

CUSTOMER INFORMATION

It is proposed to add an addendum sheet to the set which informs the customer that the set has been checked carefully - but no fault was found.

The problem was obviously caused by a scratched, dirty or copy-protected CD. In case problems remain, the customer is requested to contact the workshop directly.

The lens cleaning (method ③) should be mentioned in the addendum sheet.

The final wording in national language as well as the printing is under responsibility of the Regional Service Organizations.

④

LIQUID LENS CLEANING

Before touching the lens it is advised to clean the surface of the lens by blowing clean air over it. This to avoid that little particles make scratches on the lens.

Because the material of the lens is synthetic and coated with a special anti-reflectivity layer, cleaning must be done with a non-aggressive cleaning fluid. It is advised to use "Cleaning Solvent

The actuator is a very precise mechanical component and may not be damaged in order to guarantee its full function. Clean the lens gently (don't press too hard) with a soft and clean cotton bud moistened with the special lens cleaner.

The direction of cleaning must be in the way as indicated in the picture below.

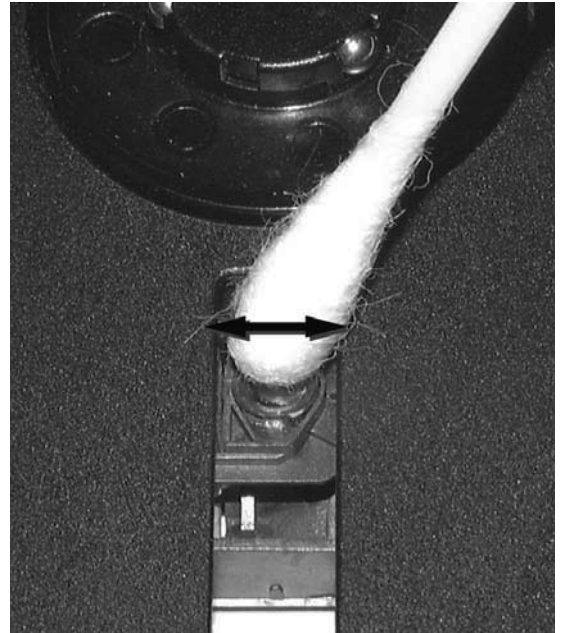

SET BLOCK DIAGRAM

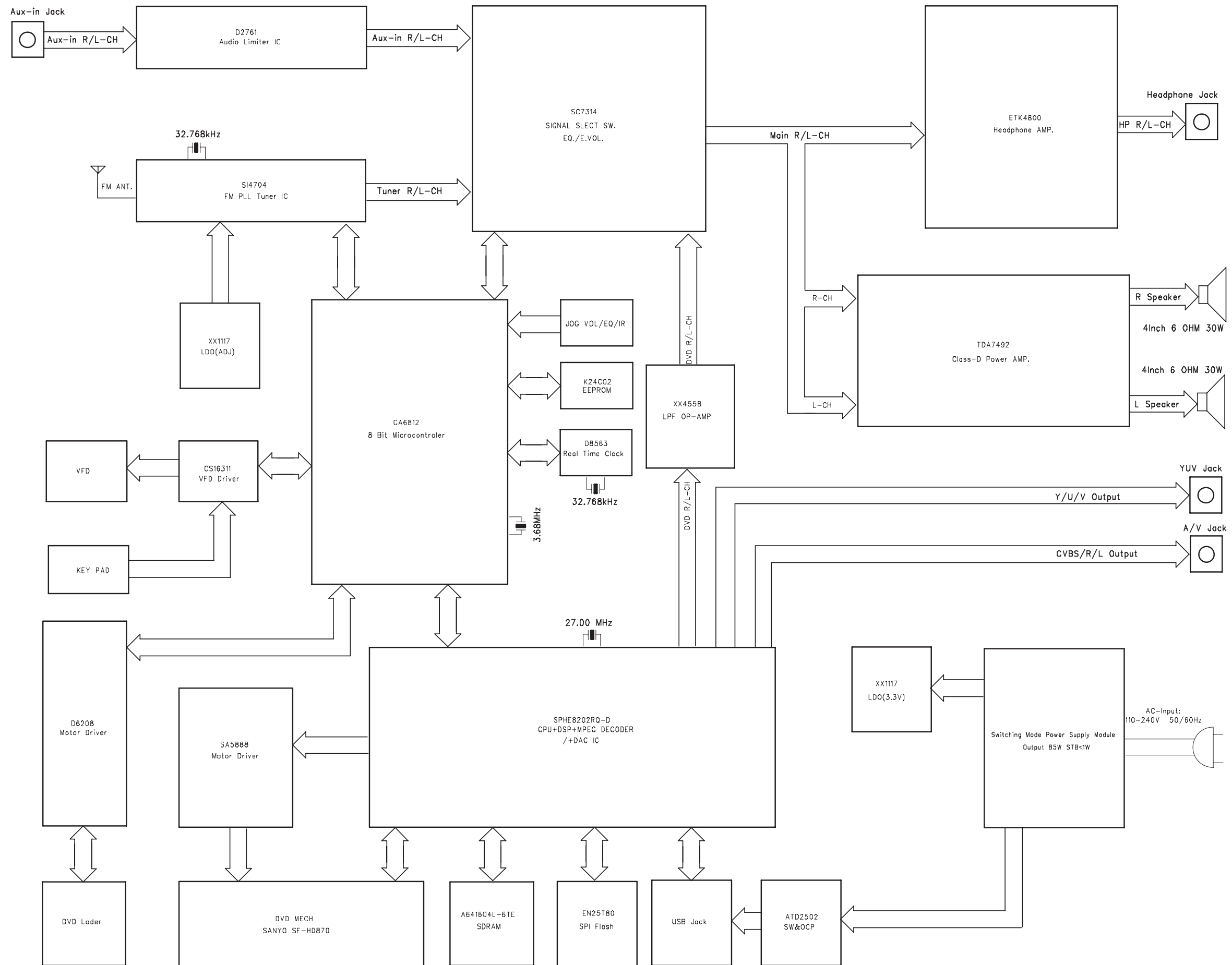

SET WIRING DIAGRAM

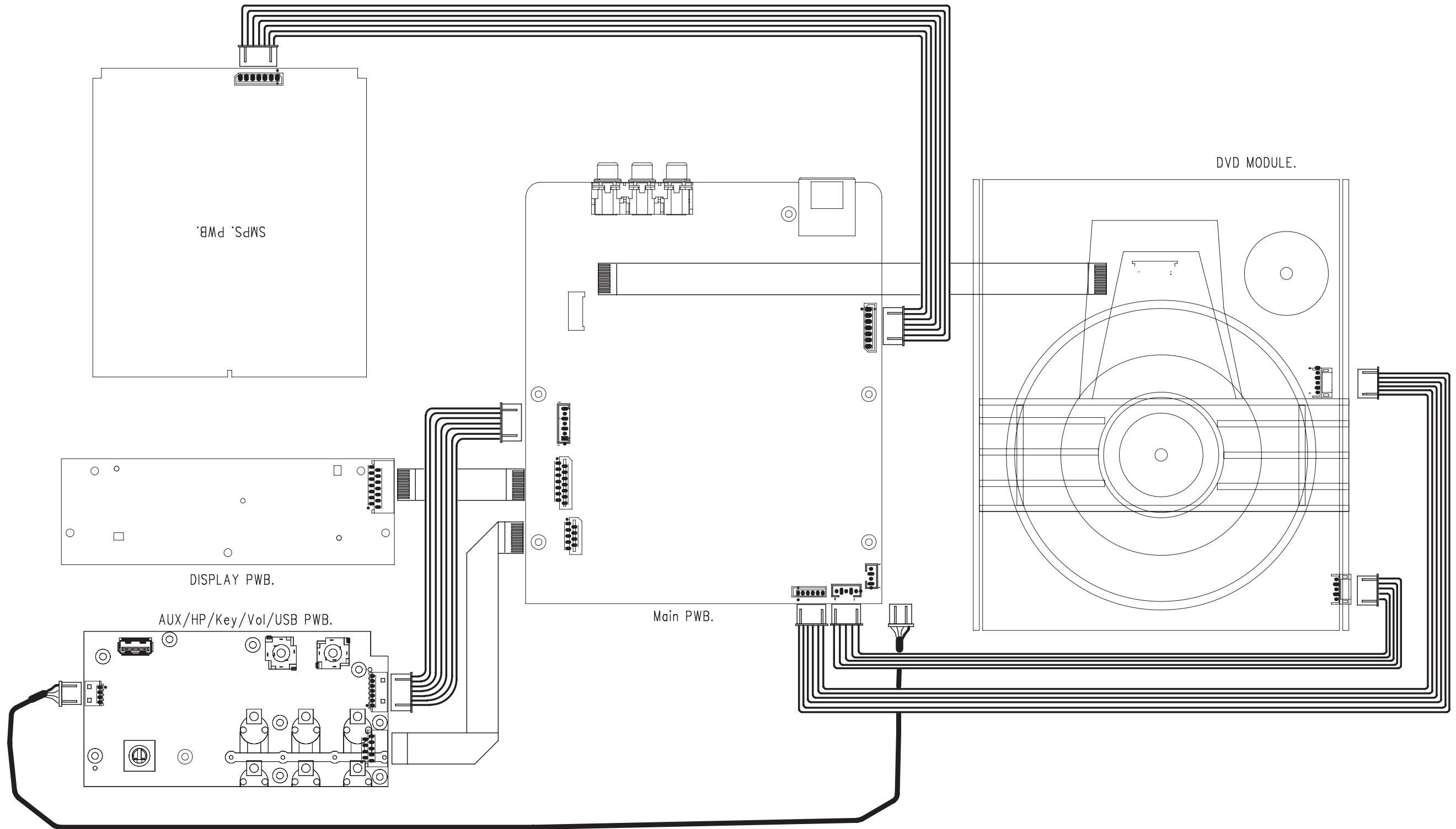

CIRCUIT DIAGRAM - MAIN BOARD AUDIO AND POWER PART

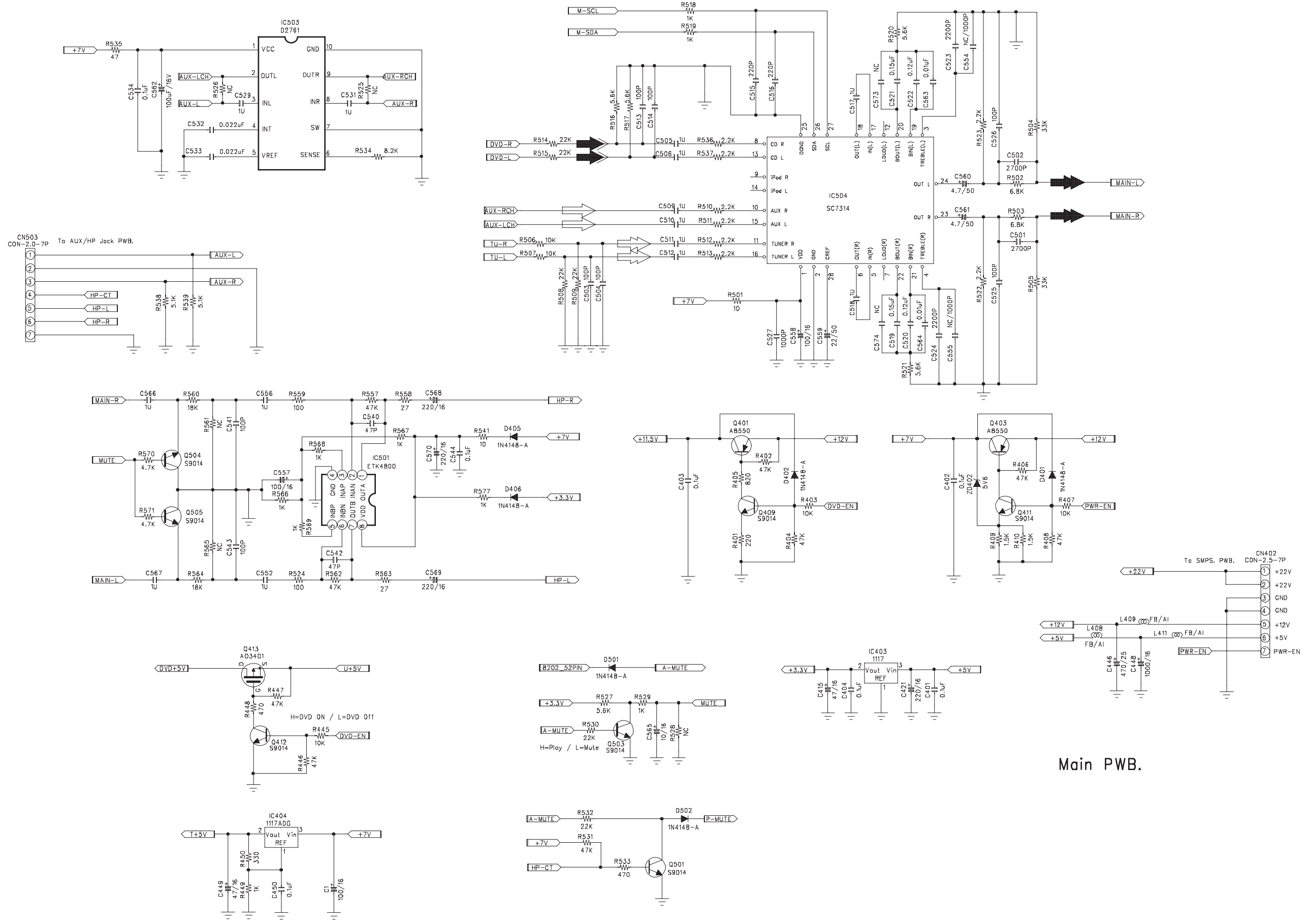

Main PWB.

**CIRCUIT DIAGRAM - MAIN BOARD
POWER AMP PART**

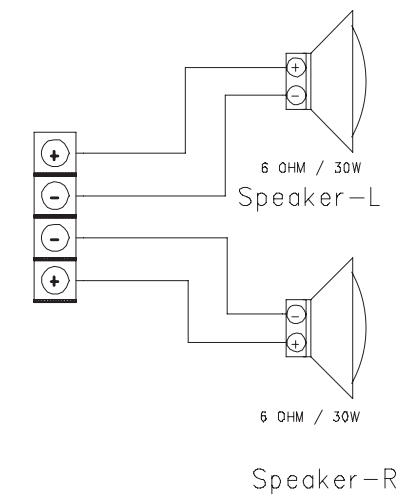
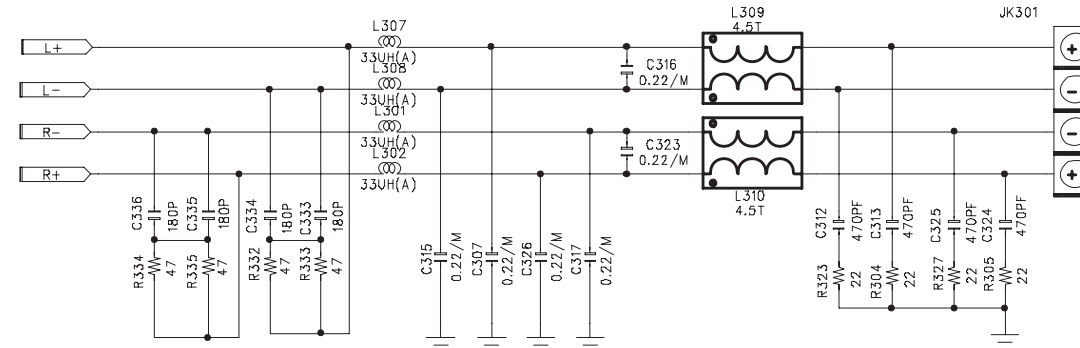
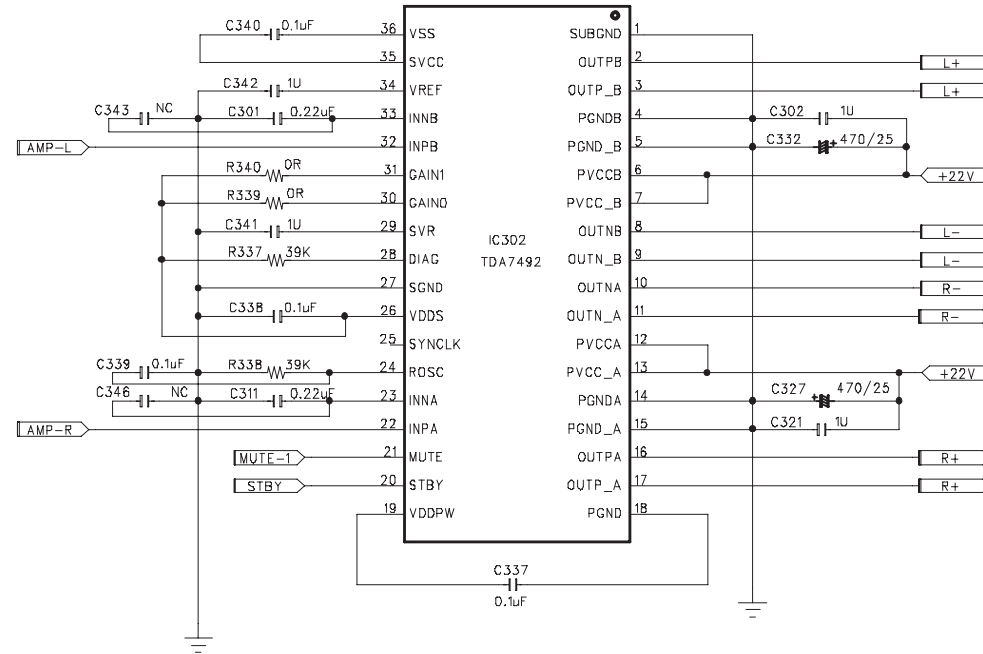
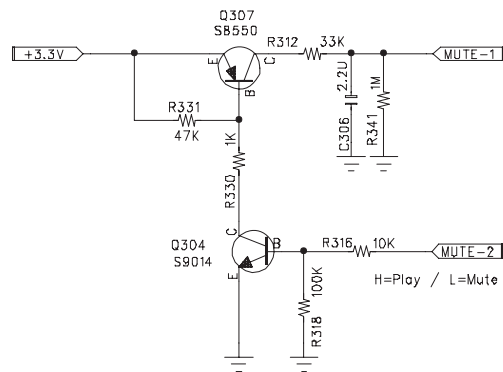
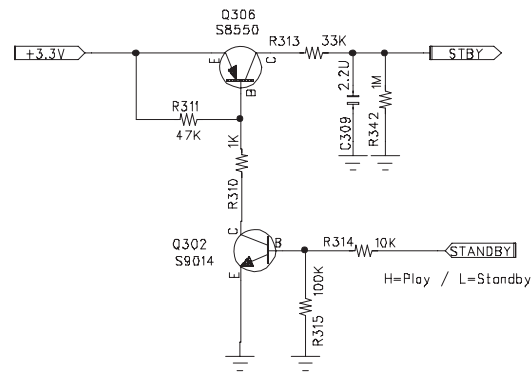
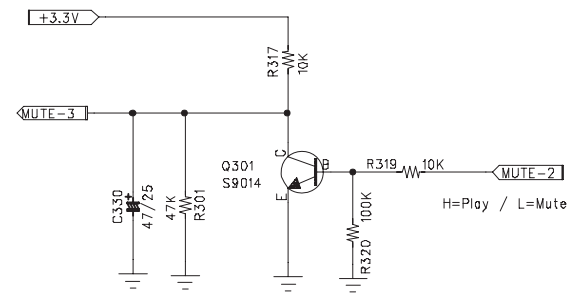
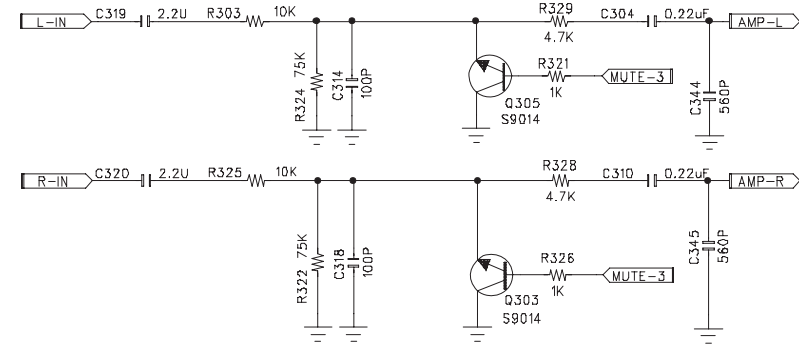
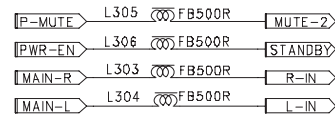

Main PWB.

**CIRCUIT DIAGARM - MAIN BOARD
MOTOR DRIVER PART**

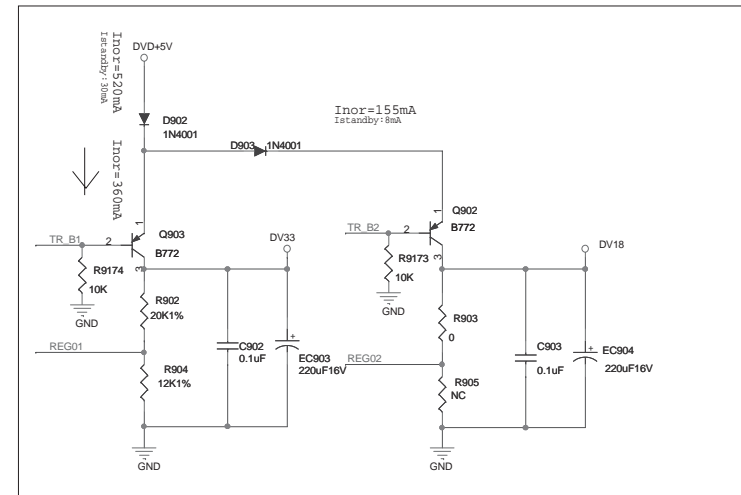

B1-U1-U1.1

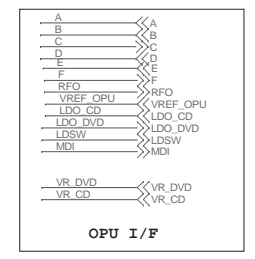
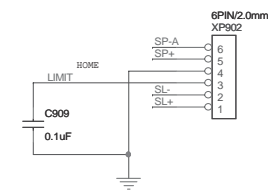
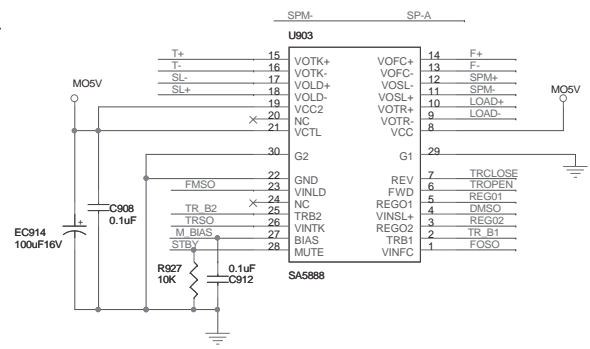
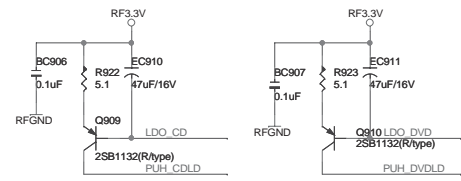
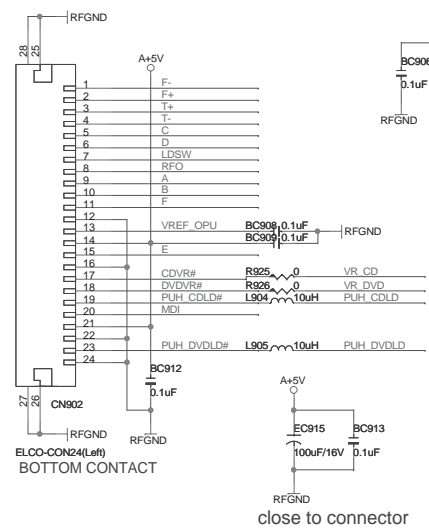

IPOD_CHARGE_CTL → IPOD_CHARGE_CTL

CIRCUIT DIAGRAM - DISPLAY AND KEY BOARD PART 1

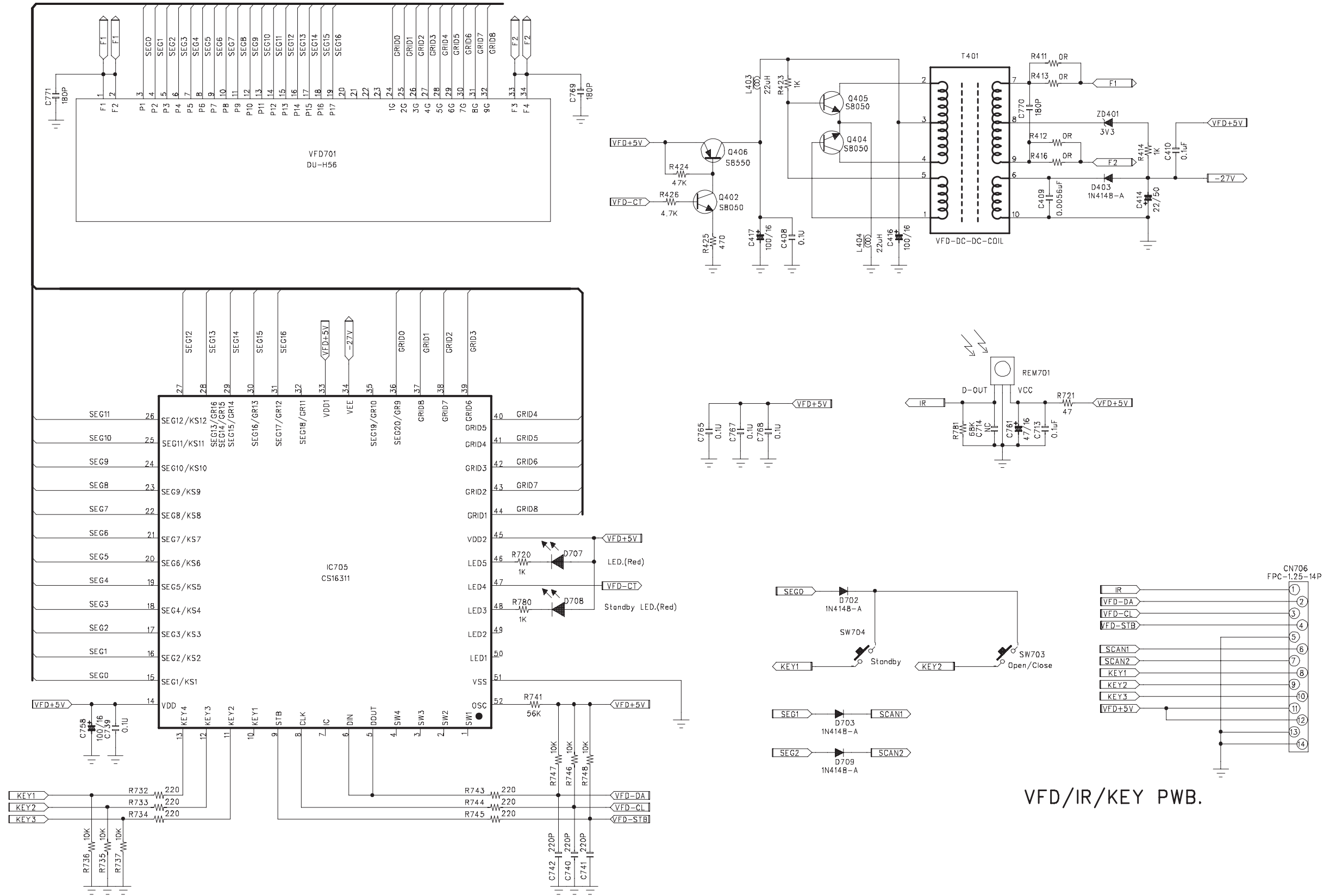

CIRCUIT DIAGRAM - DISPLAY AND KEY BOARD
PART 2

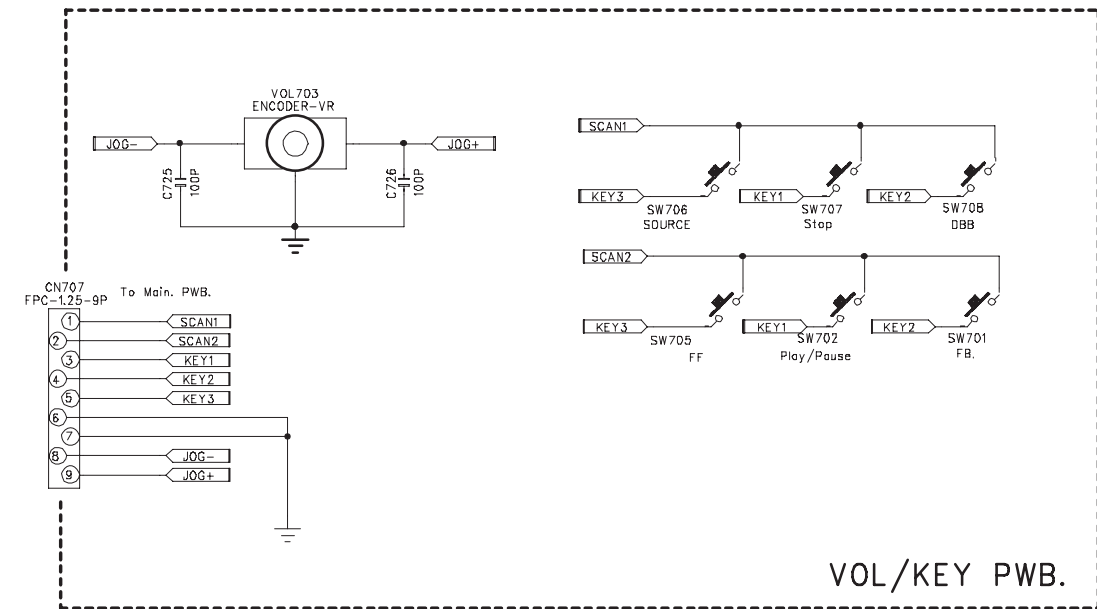
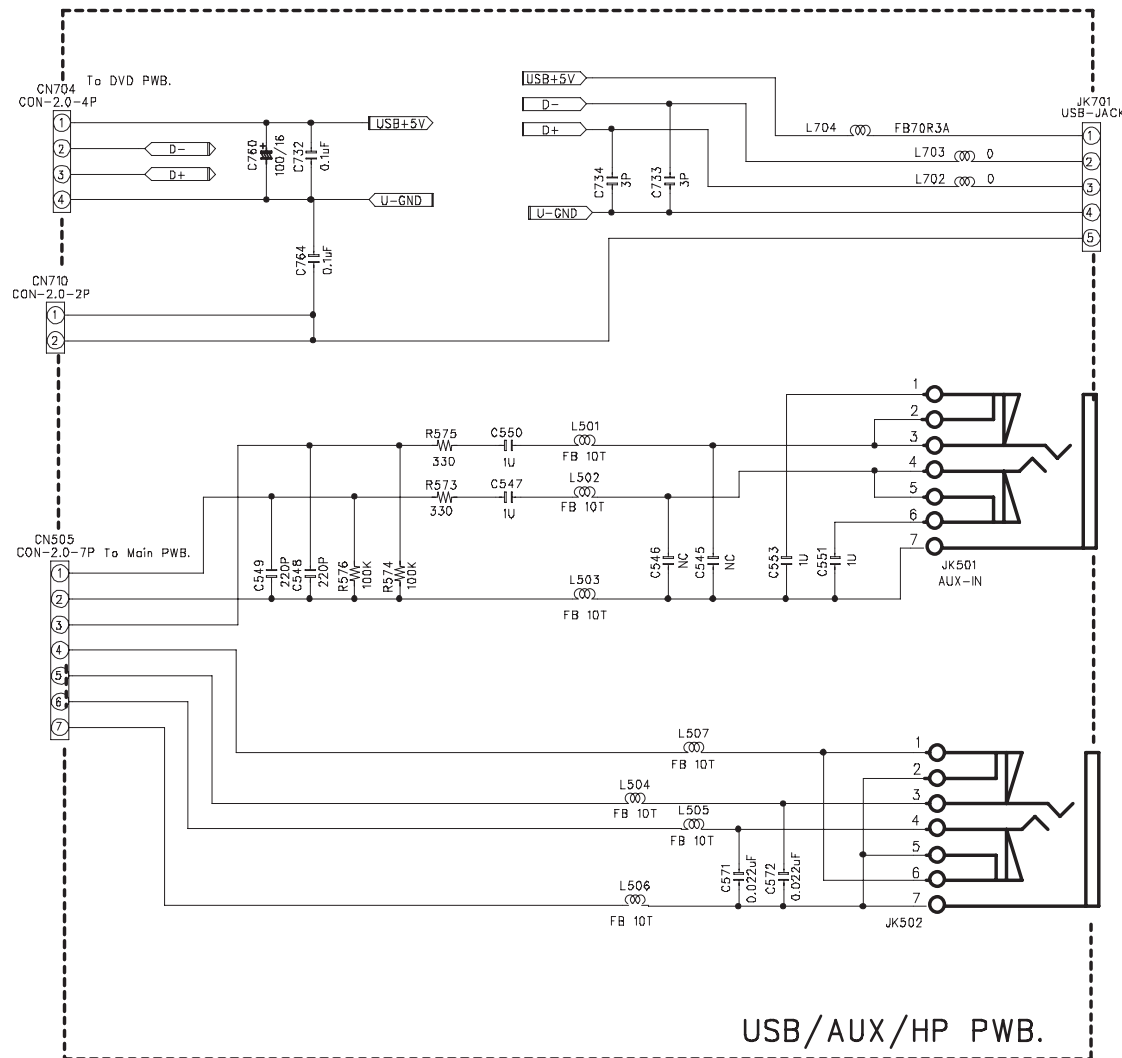
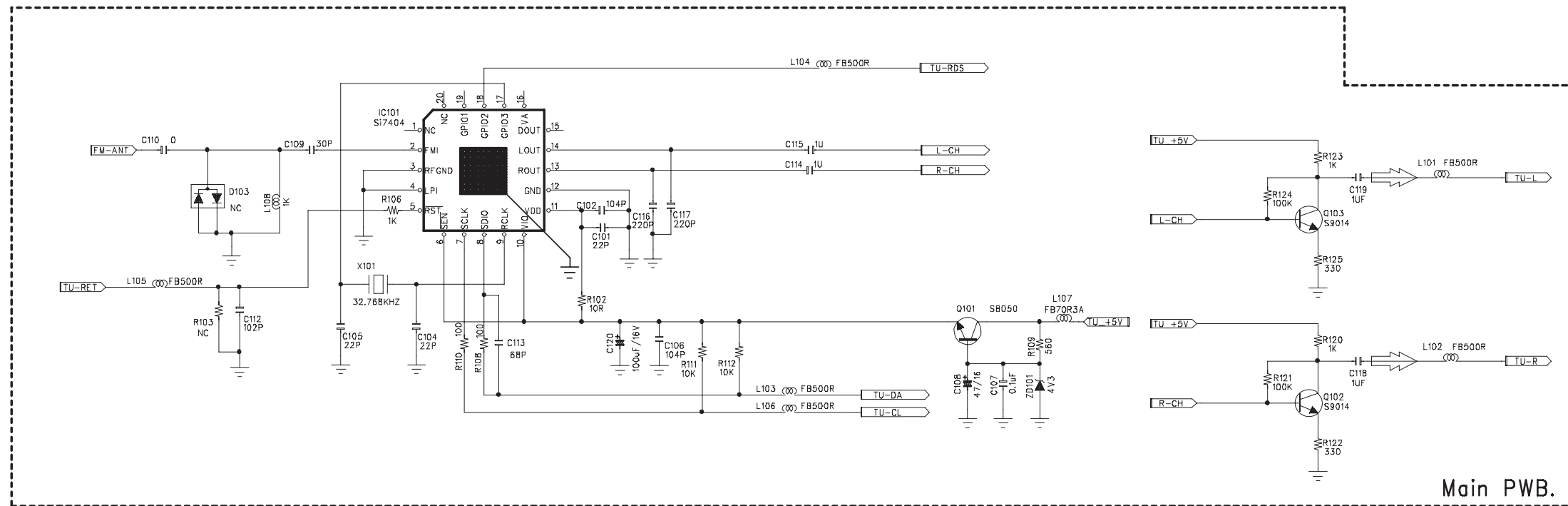

LAYOUT DIAGRAM - DISPLAY AND KEY BOARD
TOP SIDE

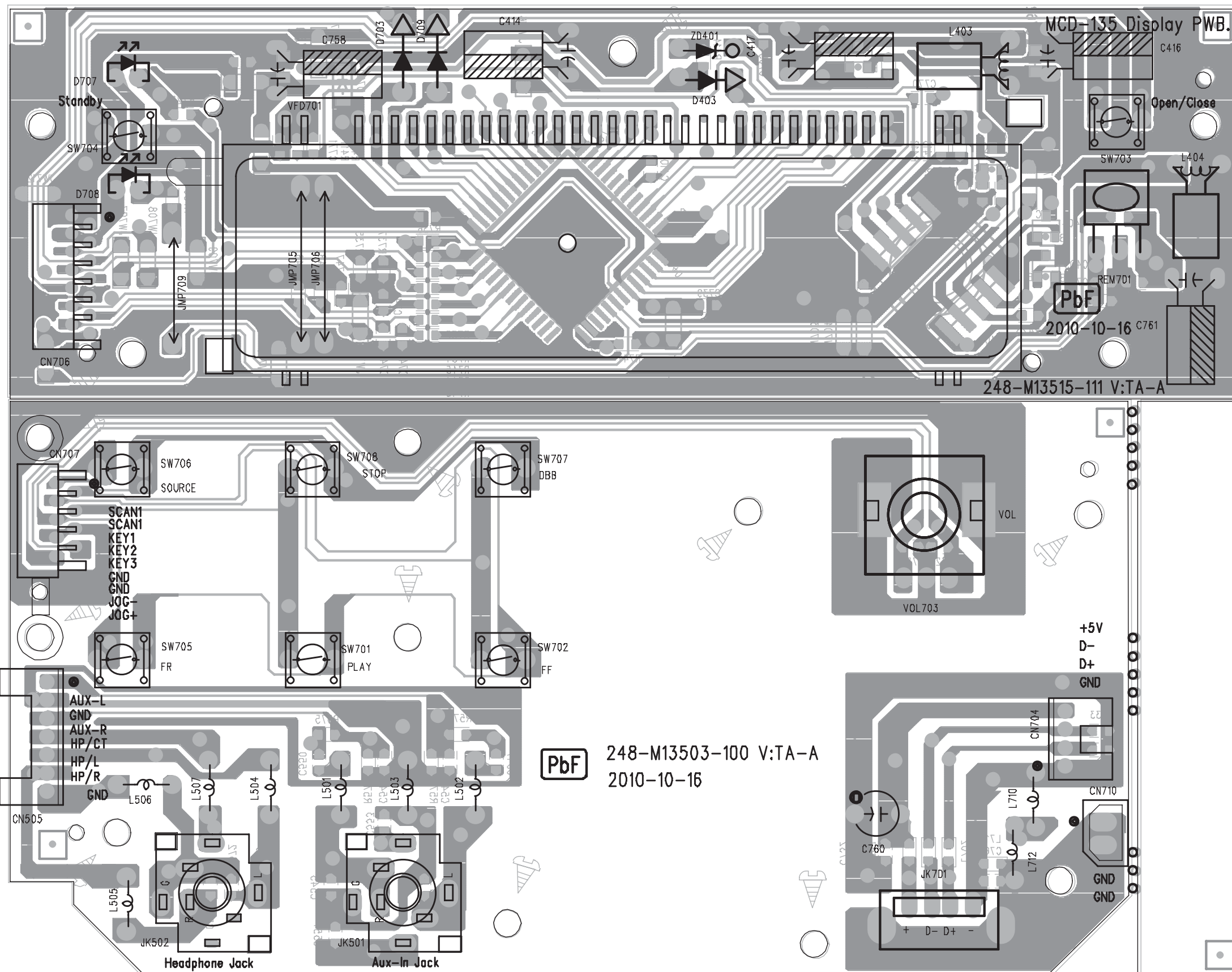

LAYOUT DIAGRAM - DISPLAY AND KEY BOARD
BOTTOM SIDE

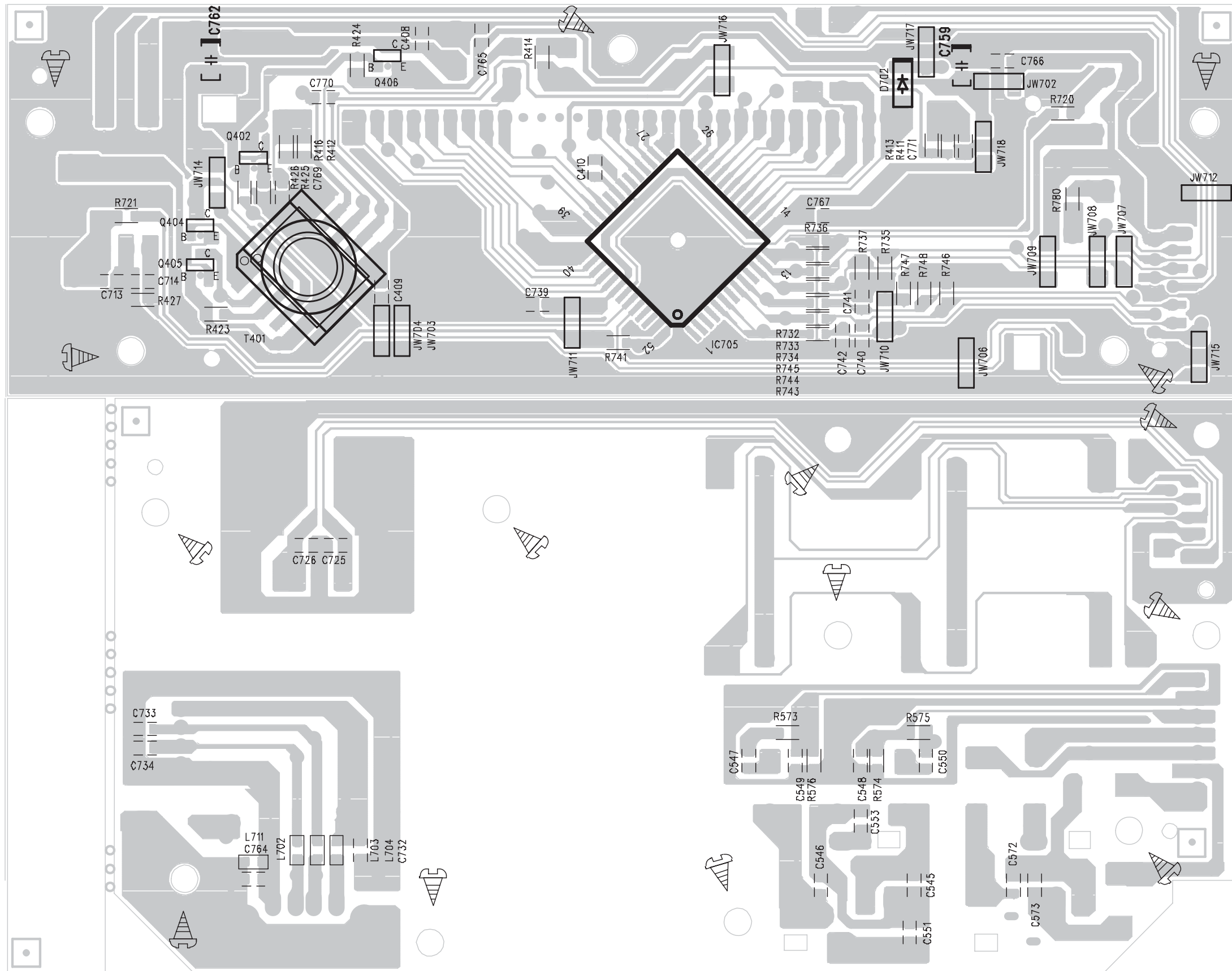

CIRCUIT DIAGRAM - SMPS POWER BOARD

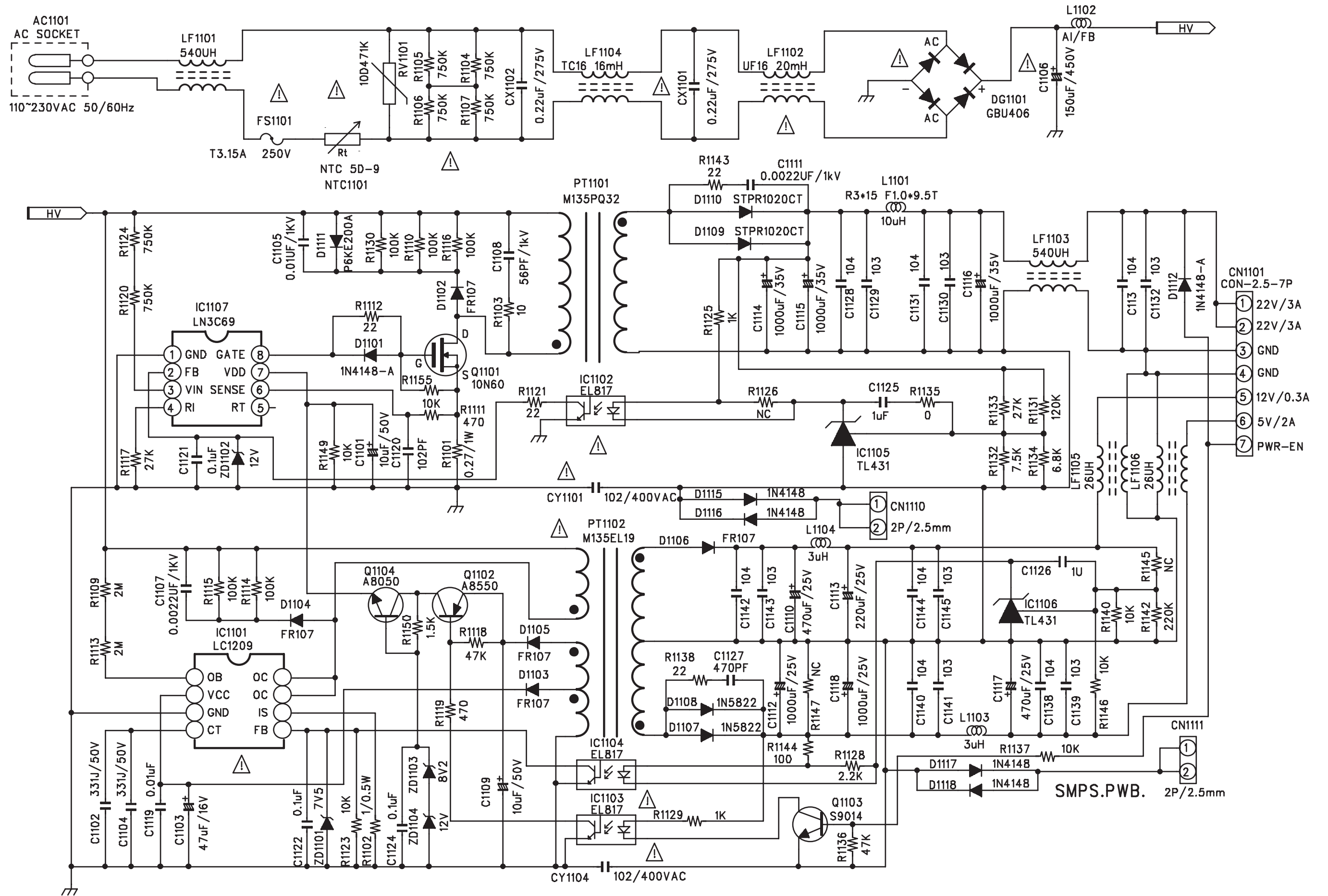

LAYOUT DIAGRAM - SMPS POWER BOARD
TOP SIDE

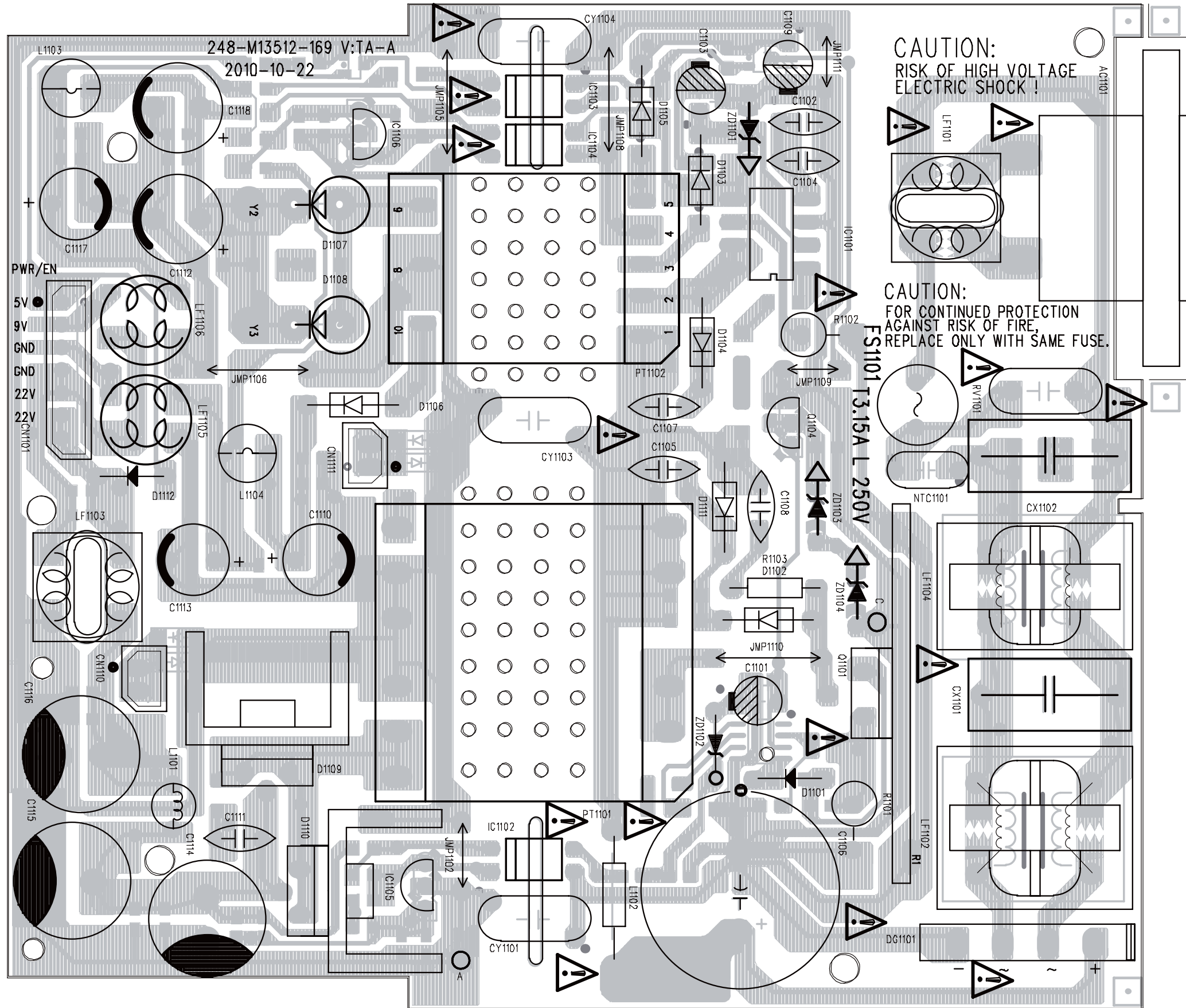

EXPLODED VIEW DIAGRAM

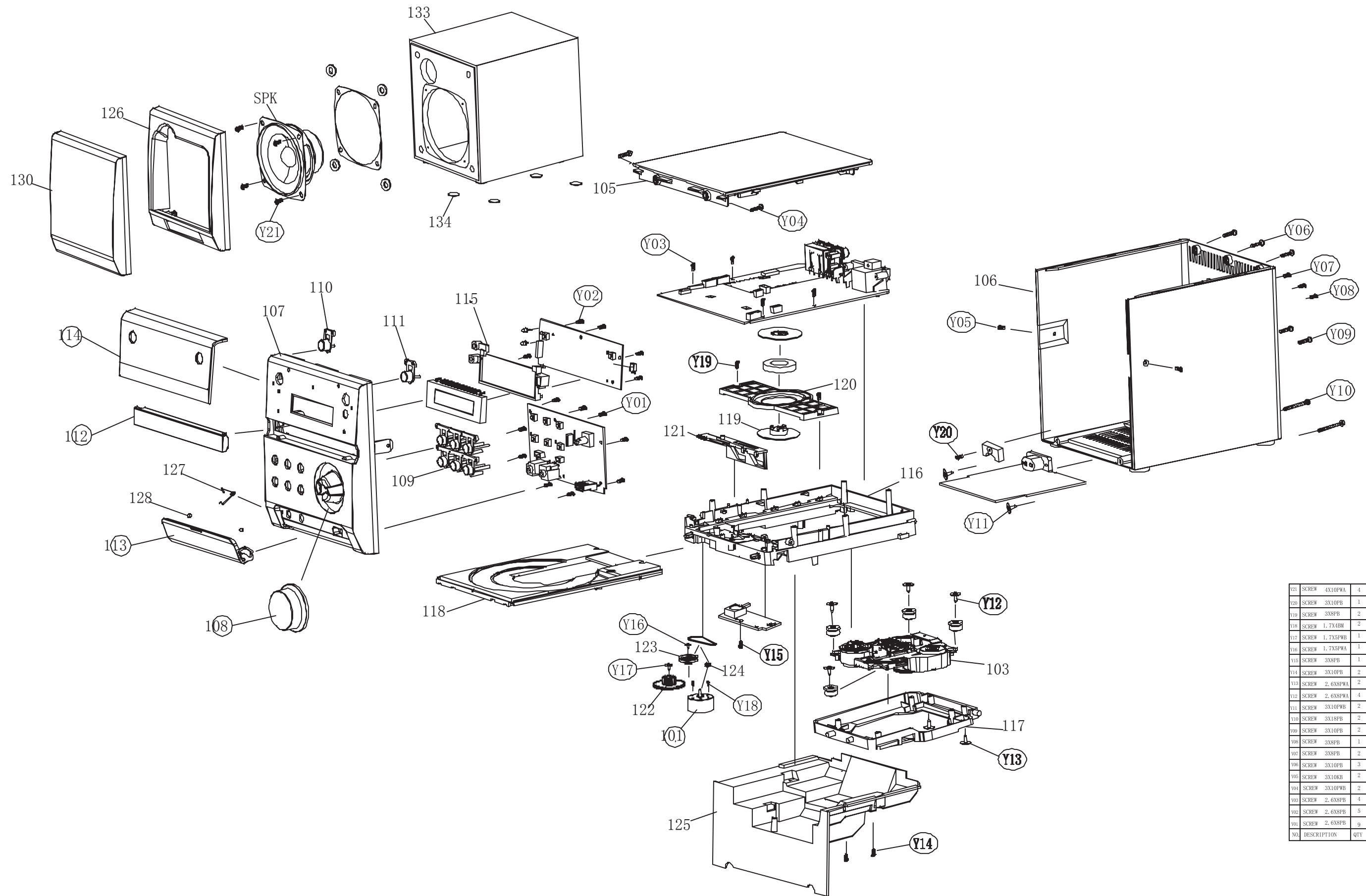

NO.	DESCRIPTION	QTY
Y21	SCREW 4X10PWA	4
Y20	SCREW 3X10PB	1
Y19	SCREW 3X8PB	2
Y18	SCREW 1.7X4BM	2
Y17	SCREW 1.7X5PWB	1
Y16	SCREW 1.7X5PWA	1
Y15	SCREW 3X8PB	1
Y14	SCREW 3X10PB	2
Y13	SCREW 2.6X8PWA	2
Y12	SCREW 2.6X8PWA	4
Y11	SCREW 3X10PWB	2
Y10	SCREW 3X18PB	2
Y09	SCREW 3X10PB	2
Y08	SCREW 3X8PB	1
Y07	SCREW 3X8PB	2
Y06	SCREW 3X10PB	3
Y05	SCREW 3X10KB	2
Y04	SCREW 3X10PWB	2
Y03	SCREW 2.6X8PB	4
Y02	SCREW 2.6X8PB	5
Y01	SCREW 2.6X8PB	9