



MCS9922
PCIe to Dual Serial Controller
Datasheet

Revision 2.00
Aug. 5th, 2011



IMPORTANT NOTICE

Copyright © 2010-2011 ASIX Electronics Corporation. All rights reserved.

DISCLAIMER

No part of this document may be reproduced or transmitted in any form or by any means, electronic or mechanical, including photocopying and recording, for any purpose, without the express written permission of ASIX. ASIX may make changes to the product specifications and descriptions in this document at any time, without notice.

ASIX provides this document “as is” without warranty of any kind, either expressed or implied, including without limitation warranties of merchantability, fitness for a particular purpose, and non-infringement.

Designers must not rely on the absence or characteristics of any features or registers marked “reserved”, “undefined” or “NC”. ASIX reserves these for future definition and shall have no responsibility whatsoever for conflicts or incompatibilities arising from future changes to them. Always contact ASIX to get the latest document before starting a design of ASIX products.

TRADEMARKS

ASIX, the ASIX logo are registered trademarks of ASIX Electronics Corporation. All other trademarks are the property of their respective owners.

Table of Contents

1	Introduction	4
1.1	Block Diagram	4
1.2	Features	5
1.3	Applications	6
1.4	Ordering information.....	6
1.5	Support	6
2	Pin Diagram.....	7
2.1	MCS9922CV-AA Pin diagram	7
3	Pin Description	8
3.1	Pin configurations	8
3.2	PCI Express Interface Signals	9
3.3	Serial Port Interface Signals.....	10
3.4	Cascade Interface Signals	11
3.5	I ² C Interface Signals	12
3.6	GPIO Interface Signals	12
3.7	Clock/Crystal Oscillator Interface Signals	13
3.8	Test Mode Signals.....	13
3.9	JTAG Interface Signals.....	13
3.10	Power Supply Signals	14
4	Function Mapping.....	16
5	Functional Description	17
5.1	PCIe Operation.....	17
5.2	PCIe Configuration Space	19
5.3	Serial Port	22
5.4	I ² C.....	24
5.5	PM Control.....	25
5.6	Cascade Interface	26
5.7	Clocks and Resets	29
5.8	GPIO.....	30
6	EEPROM Contents Layout.....	31
7	Electrical Specifications.....	34
8	Mechanical Dimensions	36
	Revision History	37

1 Introduction

MCS9922 is a single lane multifunction PCI express to I/O controller. It supports two serial ports and eight GPIO's. MCS9922 also provides an option for peripheral expansion through ASIX proprietary Cascade interface. The generic cascade interface allows interconnecting with similar chips like MCS9900 to expand the peripheral ports.

The serial ports are compatible with RS232, RS422 & RS485 standards and supports throughput from 50bps to 16Mbps. All the GPIO pins are programmable and can be used as Input or Output. An I²C interface is provided to configure MCS9922 device options through an external EEPROM.

1.1 Block Diagram

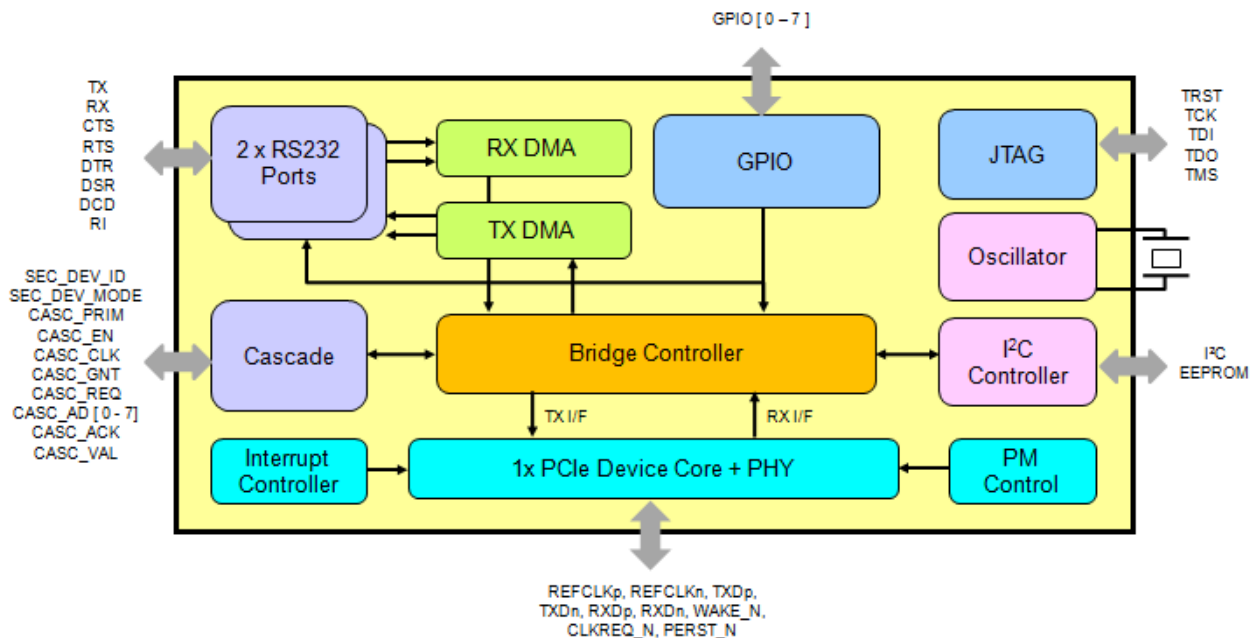

1.2 Features

PCI express

- Single-lane (X1) PCI Express End-point Controller with integrated PHY
- Compliant with PCI Express Base Specification, Revision 1.1
- Compliant with PCI Express card specifications
- Supports two PCI Express functions
- Supports auto completion of configuration requests
- Supports built in flow control
- Supports Message TLP (Error) generation
- Supports integrated time out handling of Non-posted request
- Supports both legacy and MSI Interrupt
- Supports PCIe Power Management

Serial Port

- Two 16C450 / 550 / Extended 550 / 650 / ASIX Enhanced Mode compatible UARTs
- Supports RS232, RS422 & RS485 modes
- Bi-directional speeds from 50 bps to 16 Mbps per port
- Full Serial Modem Control
- Supports Hardware, Software Flow Control
- Supports 5, 6, 7, 8 bit Serial format
- Supports Even, Odd, None, Space and Mark parity
- Supports Custom baud rate by programming internal PLL or external clock
- Supports On Chip 256 Byte depth FIFOs in Transmit, Receive path of each Serial Port
- Supports remote wakeup and power management features
- Serial Port transceiver shutdown support
- Supports Slow IrDA mode (up to 115200bps) on all Serial Ports

Cascade

MCS9922 supports a 13-Pin proprietary interface to connect to other ASIX devices for IO expansion. Through this interface, MCS9922 can be used as Cascade Secondary device and can be connected to Cascade Primary capable ASIX Devices like MCS9900.

Eg. MCS9922 can be connected to MCS9900, for following product configurations.

- PCIe to 6 Serial Ports
- PCIe to 4 Serial Ports and 1 Parallel Port

General Device Features

- I²C interface for EEPROM
- EEPROM read / write through PCIe Interface
- 8 bi-directional multi-function GPIO lines
- On chip oscillator
- Power supply : 1.2V, 3.3V

1.3 Applications

- Serial Attached Devices
- Serial Networking / Monitoring Equipment
- Data Acquisition System
- POS Terminal & Industrial PC
- Add-On I/O Cards – Serial
- Embedded systems – For I/O expansion

1.4 Ordering information

- Ordering Part Number : MCS9922CV-AA
- Operating Temperature : 0 to 85 deg C
- Package : 128 LQFP, RoHS

1.5 Support

- Reference Schematics : Available ***
- Evaluation Board : Available ***
- Software Support : Available ***
- System Design Data & Other Technical Collateral : Available ***

*** Please contact ASIX Support Team for above items, write to support@asix.com.tw

2 Pin Diagram

2.1 MCS9922CV-AA Pin diagram

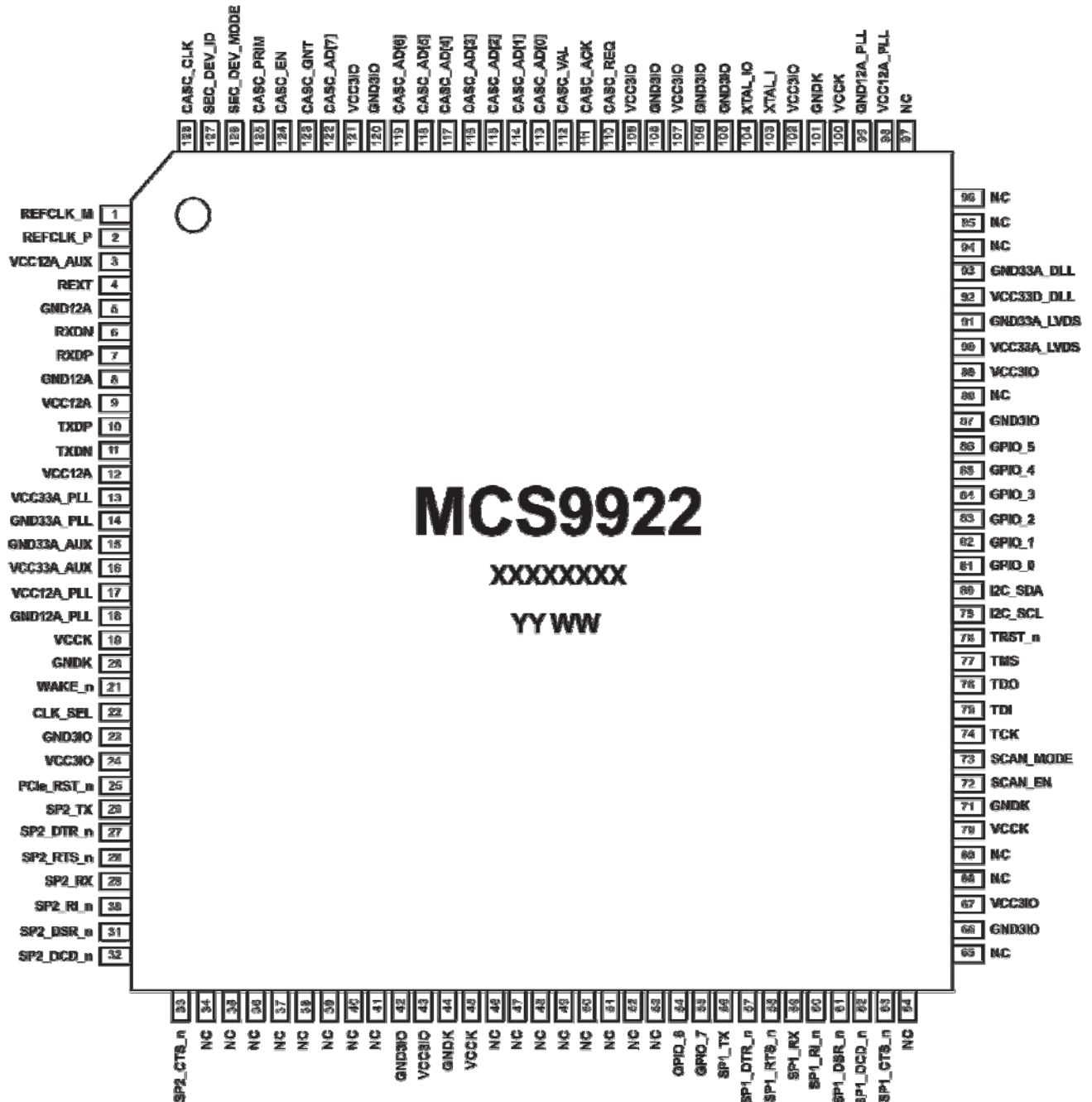

3 Pin Description

Pin Naming Convention

The Pin names use the following conventions:

“n” suffix is an active low signal, “I” – Input, “O” – Output, “P” – Passive, “DS” – Drive Strength in milli Amperes(mA), “PU” – Pull Up, “PD” – Pull Down, “N/A” – Not Applicable and “PROG” – Programmable

3.1 Pin configurations

Following table describes the pin configurations of MCS9922CV-AA device.

Pin	MCS9922	Pin	MCS9922	Pin	MCS9922	Pin	MCS9922
1	REFCLK_M	37	NC	73	SCAN_MODE	109	VCC3IO
2	REFCLK_P	38	NC	74	TCK	110	CASC_REQ
3	VCC12A_AUX	39	NC	75	TDI	111	CASC_ACK
4	REXT	40	NC	76	TDO	112	CASC_VAL
5	GND12A	41	NC	77	TMS	113	CASC_AD[0]
6	RXDN	42	GND3IO	78	TRST_n	114	CASC_AD[1]
7	RXDP	43	VCC3IO	79	I2C_SCL	115	CASC_AD[2]
8	GND12A	44	GNDK	80	I2C_SDA	116	CASC_AD[3]
9	VCC12A	45	VCCK	81	GPIO_0	117	CASC_AD[4]
10	TXDP	46	NC	82	GPIO_1	118	CASC_AD[5]
11	TXDN	47	NC	83	GPIO_2	119	CASC_AD[6]
12	VCC12A	48	NC	84	GPIO_3	120	GND3IO
13	VCC33A_PLL	49	NC	85	GPIO_4	121	VCC3IO
14	GND33A_PLL	50	NC	86	GPIO_5	122	CASC_AD[7]
15	GND33A_AUX	51	NC	87	GND3IO	123	CASC_GNT
16	VCC33A_AUX	52	NC	88	NC	124	CASC_EN
17	VCC12A_PLL	53	NC	89	VCC3IO	125	CASC_PRIM
18	GND12A_PLL	54	GPIO_6	90	VCC33A_LVDS	126	SEC_DEV_MODE
19	VCCK	55	GPIO_7	91	GND33A_LVDS	127	SEC_DEV_ID
20	GNDK	56	SP1_TX	92	VCC33D_DLL	128	CASC_CLK
21	WAKE_n	57	SP1_DTR_n	93	GND33A_DLL		
22	CLK_SEL	58	SP1_RTS_n	94	NC		
23	GND3IO	59	SP1_RX	95	NC		
24	VCC3IO	60	SP1_RI_n	96	NC		
25	PCIe_RST_n	61	SP1_DSR_n	97	NC		
26	SP2_TX	62	SP1_DCD_n	98	VCC12A_PLL		
27	SP2_DTR_n	63	SP1_CTS_n	99	GND12A_PLL		
28	SP2_RTS_n	64	NC	100	VCCK		
29	SP2_RX	65	NC	101	GNDK		
30	SP2_RI_n	66	GND3IO	102	VCC3IO		
31	SP2_DSR_n	67	VCC3IO	103	XTAL_I		
32	SP2_DCD_n	68	NC	104	XTAL_IO		
33	SP2_CTS_n	69	NC	105	GND3IO		
34	NC	70	VCCK	106	GND3IO		
35	NC	71	GNDK	107	VCC3IO		
36	NC	72	SCAN_EN	108	GND3IO		

3.2 PCI Express Interface Signals

Pin#	Pin Name	I/O/P	Type	DS	PU/PD	Description
1	REFCLK_M	I	LVDS	-	-	PCIe PHY differential PLL reference clock. Cascade Mode: Pull down using 10K Resistor.
2	REFCLK_P	I	LVDS	-	-	PCIe PHY differential PLL reference clock. Cascade Mode: Pull down using 10K Resistor.
4	REXT	O	Analog	-	-	Bandgap External Resistor (Connect this pin to ground through an external resistor of 6.2K Ω , $\pm 1\%$)
6	RXDN	I	LVDS	-	-	PCIe PHY differential negative serial data input. Cascade Mode: Pull down using 10K Resistor.
7	RXDP	I	LVDS	-	-	PCIe PHY differential positive serial data input. Cascade Mode: Pull down using 10K Resistor.
10	TXDP	O	LVDS	-	-	PCIe PHY differential positive serial data output. Cascade Mode: Leave this pin as "No Connection".
11	TXDN	O	LVDS	-	-	PCIe PHY differential negative serial data output. Cascade Mode: Leave this pin as "No Connection".
21	WAKE_n	O	LVTTL	4	PU	This is an active low signal used to reactivate the PCI Express slot's main power and reference clocks. Cascade Mode: Leave this pin as "No Connection".
22	CLK_SEL	O	LVTTL	4	PU	Used to enable/disable clock of PCI Express card.
25	PCIe_RST_n	I	LVTTL	4	PU	Active low asynchronous reset from PCIe RC

3.3 Serial Port Interface Signals

Serial Port 1

Pin#	Pin name	I/O/P	Type	DS	PU/PD	Description
56	SP1_TX	O	LVTTTL	4	–	Transmit data out to transceiver or IrDA data out to IR LED
57	SP1_DTR_n	O	LVTTTL	4	–	Data terminal ready (Active Low) Also used for setting cascade clock Pull up : Sets cascade clock to run at 62.5 MHz Pull down : Sets cascade clock to run at 96 MHz
58	SP1_RTS_n	O	LVTTTL	4	–	Request to send (Active Low)
59	SP1_RX	I	LVTTTL	4	PU	Serial receives data in from transceiver or IrDA data in from IrDA detector.
60	SP1_RI_n	I	LVTTTL	4	PU	Ring Indicator (Active Low)
61	SP1_DSR_n	I	LVTTTL	4	PU	Data Set Ready (Active Low)
62	SP1_DCD_n	I	LVTTTL	4	PU	Data Carrier Detect (Active Low)
63	SP1_CTS_n	I	LVTTTL	4	PU	Clear to send (Active Low)

Serial Port 2

Pin#	Pin name	I/O/P	Type	DS	PU/PD	Description
26	SP2_TX	O	LVTTTL	4	–	Transmit data out to transceiver or IrDA data out to IR LED
27	SP2_DTR_n	O	LVTTTL	4	–	Data terminal ready (Active Low)
28	SP2_RTS_n	O	LVTTTL	4	–	Request to send (Active Low)
29	SP2_RX	I	LVTTTL	4	PU	Serial receives data in from transceiver or IrDA data in from IrDA detector.
30	SP2_RI_n	I	LVTTTL	4	PU	Ring Indicator (Active Low)
31	SP2_DSR_n	I	LVTTTL	4	PU	Data Set Ready (Active Low)
32	SP2_DCD_n	I	LVTTTL	4	PU	Data Carrier Detect (Active Low)
33	SP2_CTS_n	I	LVTTTL	4	PU	Clear to send (Active Low)

3.4 Cascade Interface Signals

Pin#	Pin name	I/O/P	Type	DS	PU/PD	Description
110	CASC_REQ	I/O	LVTTTL	8	–	To request the arbiter to grant access to CASC_AD bus.
111	CASC_ACK	I/O	LVTTTL	8	–	Asserted by slave, in response to CASC_VAL, when it is ready to accept transfer
112	CASC_VAL	I/O	LVTTTL	8	–	1: address/data/command on CASC_AD[7:0] is valid, 0: CASC_AD is not valid
113	CASC_AD[0]	I/O	LVTTTL	8	–	To transfer Address / Data and control words
114	CASC_AD[1]	I/O	LVTTTL	8	–	To transfer Address / Data and control words
115	CASC_AD[2]	I/O	LVTTTL	8	–	To transfer Address / Data and control words
116	CASC_AD[3]	I/O	LVTTTL	8	–	To transfer Address / Data and control words
117	CASC_AD[4]	I/O	LVTTTL	8	–	To transfer Address / Data and control words
118	CASC_AD[5]	I/O	LVTTTL	8	–	To transfer Address / Data and control words
119	CASC_AD[6]	I/O	LVTTTL	8	–	To transfer Address / Data and control words
122	CASC_AD[7]	I/O	LVTTTL	8	–	To transfer Address / Data and control words
123	CASC_GNT	I/O	LVTTTL	8	–	Grant to access of CASC_AD bus
124	CASC_EN	I	LVTTTL	4	PD	1 : cascade mode enabled 0 : cascade mode disabled
125	CASC_PRIM	I	LVTTTL	4	PD	Chip is cascade secondary. Leave this pin as “No Connection”.

126	SEC_DEV_MODE	O	LVTTL	8	PD	For Non-Cascade applications, leave this pin as No Connect. When MCS9922 is used as Cascade Secondary Device, connect this pin to corresponding pin of the Cascade Primary Device.
127	SEC_DEV_ID	I	LVTTL	4	PD	Leave this pin as "No Connection"
128	CASC_CLK	O	LVTTL	8		Pull down using 1K resistor

3.5 I²C Interface Signals

Pin#	Pin name	I/O/P	Type	DS	PU/PD	Description
79	I2C_SCL	I/O	LVTTL	4	PU	2-Wire EEPROM Clock
80	I2C_SDA	I/O	LVTTL	4	PU	2-Wire EEPROM Data in/out.

3.6 GPIO Interface Signals

Pin#	Pin name	I/O/P	Type	DS	PU/PD	Description
81	GPIO_0	I/O	LVTTL	8	PU/PD	General Purpose I/O signal
82	GPIO_1	I/O	LVTTL	8	PU/PD	General Purpose I/O signal
83	GPIO_2	I/O	LVTTL	8	PU/PD	General Purpose I/O signal
84	GPIO_3	I/O	LVTTL	8	PU/PD	General Purpose I/O signal
85	GPIO_4	I/O	LVTTL	8	PU/PD	General Purpose I/O signal
86	GPIO_5	I/O	LVTTL	8	PU/PD	General Purpose I/O signal
54	GPIO_6	I/O	LVTTL	8	PU/PD	General Purpose I/O signal
55	GPIO_7	I/O	LVTTL	8	PU/PD	General Purpose I/O signal

3.7 Clock/Crystal Oscillator Interface Signals

Pin#	Pin name	I/O/P	Type	DS	PU/PD	Description
103	XTAL_I	I	Analog	–	–	Crystal input for PLL, 24 ~ 42MHz
104	XTAL_IO	I/O	Analog	–	–	Feedback signal for the oscillator pad

3.8 Test Mode Signals

Pin#	Pin name	I/O/P	Type	DS	PU/PD	Description
72	SCAN_EN	I	LVTTTL	4	PD	Scan enable signal
73	SCAN_MODE	I	LVTTTL	4	–	This signal is used as clock input in cascade mode. Cascade mode: Cascade Clock driven by 'primary' through 'CASC_CLK' should be interfaced to this pin. Non-Cascade Mode: Pull Down using 1K resistor.

3.9 JTAG Interface Signals

Pin#	Pin name	I/O/P	Type	DS	PU/PD	Description
74	TCK	I	LVTTTL	4	–	JTAG chain clock
75	TDI	I	LVTTTL	4	PD	JTAG chain input
76	TDO	O	LVTTTL	4	–	JTAG chain output
77	TMS	I	LVTTTL	4	PD	JTAG chain Test mode select
78	TRST_n	I	LVTTTL	4	PU	JTAG Reset (pull-up is recommended on JTAG Reset)

3.10 Power Supply Signals

Pin#	Pin name	I/O/P	Type	DS	PU/PD	Description
3	VCC12A_AUX	P	PWR	–	–	1.2V Analog Power Supply
9	VCC12A	P	PWR	–	–	1.2V Analog Power Supply
12	VCC12A	P	PWR	–	–	1.2V Analog Power Supply
13	VCC33A_PLL	P	PWR	–	–	3.3V Analog Power Supply
16	VCC33A_AUX	P	PWR	–	–	3.3V Analog Power Supply
17	VCC12A_PLL	P	PWR	–	–	1.2V Analog Power Supply
19	VCCK	P	PWR	–	–	1.2V Digital Power Supply
24	VCC3IO	P	PWR	–	–	3.3V Digital Power Supply
43	VCC3IO	P	PWR	–	–	3.3V Digital Power Supply
45	VCCK	P	PWR	–	–	1.2V Digital Power Supply
67	VCC3IO	P	PWR	–	–	3.3V Digital Power Supply
70	VCCK	P	PWR	–	–	1.2V Digital Power Supply
89	VCC3IO	P	PWR	–	–	3.3V Digital Power Supply
90	VCC33A_LVDS	P	PWR	–	–	3.3V Analog Power Supply
92	VCC33D_DLL	P	PWR	–	–	3.3V Digital Power Supply
98	VCC12A_PLL	P	PWR	–	–	1.2V Analog Power Supply
100	VCCK	P	PWR	–	–	1.2V Digital Power Supply
102	VCC3IO	P	PWR	–	–	3.3V Digital Power Supply
107	VCC3IO	P	PWR	–	–	3.3V Digital Power Supply
109	VCC3IO	P	PWR	–	–	3.3V Digital Power Supply
121	VCC3IO	P	PWR	–	–	3.3V Digital Power Supply
5	GND12A	P	PWR	–	–	Analog Ground
8	GND12A	P	PWR	–	–	Analog Ground
14	GND33A_PLL	P	PWR	–	–	Analog Ground



MCS9922 PCIe to Dual Serial Controller

Pin#	Pin name	I/O/P	Type	DS	PU/PD	Description
15	GND33A_AUX	P	PWR	–	–	Analog Ground
18	GND12A_PLL	P	PWR	–	–	Analog Ground
20	GNDK	P	PWR	–	–	Digital Ground
23	GND3IO	P	PWR	–	–	Digital Ground
42	GND3IO	P	PWR	–	–	Digital Ground
44	GNDK	P	PWR	–	–	Digital Ground
66	GND3IO	P	PWR	–	–	Digital Ground
71	GNDK	P	PWR	–	–	Digital Ground
87	GND3IO	P	PWR	–	–	Digital Ground
91	GND33A_LVDS	P	PWR	–	–	Analog Ground
93	GND33A_DLL	P	PWR	–	–	Analog Ground
99	GND12A_PLL	P	PWR	–	–	Analog Ground
101	GNDK	P	PWR	–	–	Digital Ground
105	GND3IO	P	PWR	–	–	Digital Ground
106	GND3IO	P	PWR	–	–	Digital Ground
108	GND3IO	P	PWR	–	–	Digital Ground
120	GND3IO	P	PWR	–	–	Digital Ground

Note: Pin Numbers 34, 35, 36, 37, 38, 39, 40, 41, 46, 47, 48, 49, 50, 51, 52, 53, 64, 65, 68, 69, 88, 94, 95, 96 and 97 are No Connect Pins for MCS9922.

4 Function Mapping

Function Mapping

Function	Non Cascade Mode	Cascade Mode	
	2 Serial	6 Serial	4 Serial + 1 Parallel
Function 0	Serial Port 1	Serial Port 1 Serial Port 5	Serial Port 1 Serial Port 3
Function 1	Serial Port 2	Serial Port 2 Serial Port 6	Serial Port 2 Serial Port 4
Function 2	–	Serial Port 3	Parallel Port 1
Function 3	–	Serial Port 4	–

5 Functional Description

MCS9922CV-AA is a single lane PCI Express based multifunction peripheral controller which supports 2-Port UART Controller, Cascade Controller, GPIO Controller, an I²C Controller and a bridge to control the transfers between the interfaces and PCIe.

The Serial port controllers are compatible with 16C450/550/Extended 550. It supports RS232, RS422 and RS485 standards with bi-directional speeds from 50bps to 16Mbps/port. MCS9922 also supports Custom BAUD rates with external clock or by programming internal PLL. Each Serial port controller uses an on-chip 256 byte deep FIFO in Transmit and receive paths.

The Cascade interface is a 13-pin ASIX proprietary interface which supports to add another cascade supported chip to expand the peripheral functions.

An I²C master interface is included to be able to connect to EPROM that could store PCIe device configuration. The 8-GPIO pins are programmable as an Input or Output.

5.1 PCIe Operation

PCIe is divided into three major blocks as Physical layer, Data link layer and Transaction layer. Physical link layer and Transaction layer together comprises PCIe core. Their functionality is explained below.

PCIe PHY

The Physical Layer isolates the Transaction and Data Link Layers from the signaling technology used for Link data interchange. The Physical Layer is divided into the logical and electrical functional sub-blocks.

The logical sub-block has two main sections: A transmit section that prepares outgoing information passed from the Data Link Layer for transmission by the electrical sub-block, and a receiver section that identifies and prepares received information before passing it to the Data Link Layer. The logical sub-block and electrical sub-block coordinate the state of each transceiver through a status and control register interface or functional equivalent. The logical sub-block directs control and management functions of the Physical Layer.

The electrical sub-block contains a Transmitter and a Receiver. The Transmitter is supplied by the logical sub-block with Symbols which it serializes and transmits onto a Lane. The Receiver is supplied with serialized Symbols from the Lane. It transforms the electrical signals into a bit stream which is de-serialized and supplied to the logical sub-block along with a Link clock recovered from the incoming serial stream.

The Physical Layer is responsible for the following:

- Power management
- Width and lane negotiation
- Reset/hot-plug control
- 8-bit/10-bit encoding/decoding
- Scrambling/de-scrambling
- Embedded clock tuning and alignment
- Transmission and reception circuit
- Elastic buffer
- Data Link Layer

The Data Link Layer

The Data Link Layer acts as an intermediate stage between the Transaction Layer and the Physical Layer. The Data Link Layer is responsible for reliably conveying Transaction Layer Packets (TLPs) supplied by the Transaction Layer across a PCI Express Link to the other component's Transaction Layer

The Data Link Layer is responsible for the following:

- Link management including TLP acknowledgment
- Retry mechanism in case of a non-acknowledged packet
- Flow control across the Link (transmission and reception)
- Power management
- CRC generation and CRC checking
- Error reporting

Transaction Layer/User Interface Layer

Transaction layer and User interface layer together perform all transaction layer functionalities. User interface layer defines a plug-and-play type interface mechanism to accept TLPs from user space for transmission, and to pass received TLPs on reception.

The Transaction Layer is primarily responsible for the following:

- Assembly and disassembly of Transaction Layer packets (TLPs)
- Storage of configuration information
- Converts received Completion packets into data payloads,
- Updates status information
- Responsible for flow control services
- Ordering rules
- Power management services
- PCIe Bridge
- Master Slave Bridge is divided into PCIe packet formatter, PCIe target interface block, Mater arbiter, Slave de-mux and VCI interface block.

5.2 PCIe Configuration Space

The following table describes PCIe configuration space register value details for Non-Cascade and Cascade modes supported by MCS9922.

Non cascade mode

Function	Register	MCS9922CV-AA
Function0	Device ID	16'h9922
	Vendor ID	16'h9710
	Revision ID	'h0
	Class code	'h7
	Sub Class Code	'h0
	Program interface	'h2
	Sub Vendor ID	'hA000
	Sub Device ID	'h1000
	Power Management Cap	16'h060F
	extended Capabilities	'h1
	Device Capabilities	16'h8302
	Link Capabilities	'h7
	MSI & Clock Power Mgmt Enable	8'h19
	Interrupt Pin	'h1
Function1	Device ID	16'h9922
	Vendor ID	16'h9710
	Revision ID	'h0
	Class code	'h7
	Sub Class Code	'h0
	Program interface	'h2
	Sub Vendor ID	'hA000
	Sub Device ID	'h1000

Function	Register	MCS9922CV-AA
	Power Management Cap	16'h060F
	extended Capabilities	'h1
	Device Capabilities	16'h8302
	Link Capabilities	'h7
	MSI & Clock Power Mgmt Enable	8'h19
	Interrupt Pin	'h2

Cascade mode

Function	Register	4S+2S	2S1P+2S
Function0	Device ID	16'h9900	16'h9900
	Vendor ID	'h9710	'h9710
	Revision ID	'h0	'h0
	Class code	'h7	'h7
	Sub Class Code	'h80	'h80
	Program interface	'h0	'h0
	Sub Vendor ID	'hA000	'hA000
	Sub Device ID	'h3002	'h3002
	Power Management Cap	16'h060F	16'h060F
	extended Capabilities	'h1	'h1
	Device Capabilities	16'h8302	16'h8302
	Link Capabilities	'h7	'h7
	MSI & Clock Power Mgmt Enable	8'h29	8'h29
	Interrupt Pin	'h1	'h1
Function1	Device ID	16'h9900	16'h9900
	Vendor ID	'h9710	'h9710
	Revision ID	'h0	'h0
	Class code	'h7	'h7
	Sub Class Code	'h80	'h80
	Program interface	'h0	'h0
	Sub Vendor ID	'hA000	'hA000
	Sub Device ID	'h3002	'h3002
	Power Management Cap	16'h060F	16'h060F



MCS9922

PCIe to Dual Serial Controller

Function	Register	4S+2S	2S1P+2S
	extended Capabilities	'h1	'h1
	Device Capabilities	16'h8302	16'h8302
	Link Capabilities	'h7	'h7
	MSI & Clock Power Mgmt Enable	8'h29	8'h29
	Interrupt Pin	'h2	'h2
Function2	Device ID	16'h9900	16'h9900
	Vendor ID	'h9710	'h9710
	Revision ID	'h0	'h0
	Class code	'h7	'h7
	Sub Class Code	'h80	'h80
	Program interface	'h0	'h0
	Sub Vendor ID	'hA000	'hA000
	Sub Device ID	'h3011	'h3012
	Power Management Cap	16'h060F	16'h060F
	extended Capabilities	'h1	'h1
	Device Capabilities	16'h8302	16'h8302
	Link Capabilities	'h7	'h7
	MSI & Clock Power Mgmt Enable	8'h29	8'h29
	Interrupt Pin	'h3	'h3
Function3	Device ID	16'h9900	'hFFFF
	Vendor ID	'h9710	'hFFFF
	Revision ID	'h0	'h0
	Class code	'h7	'h0
	Sub Class Code	'h80	'h0
	Program interface	'h0	'h0
	Sub Vendor ID	'hA000	'h0
	Sub Device ID	'h1000	'h0
	Power Management Cap	16'h060F	'h0
	extended Capabilities	'h1	'h0
	Device Capabilities	16'h8302	'h0
	Link Capabilities	'h7	'h0
	MSI & Clock Power Mgmt Enable	8'h29	'h0
	Interrupt Pin	'h4	'h0

5.3 Serial Port

Serial port is a full-duplex device which uses separate lines for transmitting and receiving data to send and receive data at the same time. When a character is about to be transmitted, a start bit is sent. A start bit has a value of 0 (also called a space state). Thus, when the line switches from a value of 1 to a value of 0, the receiver is alerted that a data character is about to be sent. Once the start bit has been sent, the transmitter sends the actual data bits. There may either be 5, 6, 7 or 8 data bits, depending on the number you have selected. Both receiver and the transmitter must agree on the number of data bits, as well as the baud rate.

Notice, when only 7 data bits are employed, and cannot send ASCII values greater than 127. Likewise, using 5 bits limits the highest possible value to 31. After the data has been transmitted, a stop bit is sent. A stop bit has a value of 1 or a mark state and it can be detected correctly even if the previous data bit also had a value of 1. This is accomplished by the stop bit's duration. Stop bits can be 1, 1.5 or 2 bit periods in length.

Besides the synchronization provided by the use of start and stop bits, an additional bit called a parity bit may optionally be transmitted along with the data. A parity bit affords a small amount of error checking, to help detect data corruption that might occur during transmission. You can choose even parity, odd parity, mark parity, space parity or none at all. When even or odd parity is being used, the number of marks (logical 1 bit) in each data byte is counted, and a single bit is transmitted following the data bits to indicate whether the number of 1 bit just sent is even or odd.

The Serial port implements the Enhanced mode and all of its features and it is backward compatible to the other modes. Each serial port controller has register logic controlling baud rates (50 bps – 16 Mbps), stop bits, parity bit settings. In addition, this block has serial port specific registers for interrupts, line status, line control features which can be accessed by software. The serial port controllers can interface to external RS232/RS422/RS485 transceivers. All the modes have some extra features to enhance the performance.

The different modes of serial port are:

- UART 16C450(Default Mode)
- UART 16C550
- UART 16C550 Ex
- UART 16C650 Mode
- ASIX Enhanced Mode

UART 16C450 Mode

This mode of operation is also known as Byte mode of operation. After the power on reset, the default UART operating mode is set to 16C450.

UART 16C550 Mode

After the hardware reset, writing a 1 to FCR [0] register increases the FIFO size to 16, providing the compatibility with 16C550 type of devices. This mode of operation also does not have any enhanced features. Support all the features of 450 mode.

UART 16C550 Extended Mode

After the hardware reset, writing a 1 to FCR [0] and enabling the FIFOSEL signal the UART goes in to the 16C550 extended mode. In this mode the FIFO size increases to 128 from 16. This mode of operation also does not have any enhanced features. Support all the features of 16C550 mode.

UART 16C650 Mode

UART is compatible with 16C650 mode when the EFR [4] is set, i.e. the device is in the enhanced mode. In 16C650 mode, software drivers usually put the device in the enhanced mode. Running 16C650 drivers on the UART channel will result in 16C650 compatibility mode with 128 deep FIFOs, as long as the FCR [0] register is set. Support all the features of 16C550 Ex mode.

ASIX Enhanced Mode

The additional features offered in ASIX Enhanced mode generally apply when the UART is in enhanced mode. Flow control and High baud rate support can be achieved in this mode of operation. In enhanced mode, the FIFO size is 128 bytes. ASIX Enhanced mode specific features are enabled using the additional control register ACR.

5.4 I²C

All I²C devices are connected through two wires: serial data (SDA) and serial clock (SCL). I²C has a master/slave protocol. The master initiates the communication. Since there are only two wires, this protocol includes the extra overhead of the addressing and acknowledgment mechanisms.

Serial Data: The serial data SDA is a bi-directional pin used to transfer addresses and data into and data out of the device. It is an open drain terminal; therefore, the SDA bus requires a pull-up resistor to VCC (typical 10 kΩ for 100 kHz, 2 kΩ for 400 kHz and 1 MHz). For normal data transfer SDA is allowed to change only during SCL low. Changes during SCL high are reserved for indicating the START and STOP conditions.

Serial Clock: The serial clock SCL is a bi-directional pin used to synchronize the data transfer from and to the device.

Address inputs: The address inputs A0, A1, A2 are used by the slave for multiple device operations. The logic levels on these inputs are compared with the corresponding bits in the slave address.

EEPROM Access

I²C operation is performed at address: GPIO_I2C_BAR5+0xC8.

The 32-bit information sent at this address is specified in tsif_cfg_data_in register. The details of this register are as follows:

Bits	Type	Reset	Name	Description
[31]	RW	0	tsif_cfg_data_in	If '1' specifies write to EPROM. If '0' specifies read from EEPROM.
[30:25]	RW	0	tsif_cfg_data_in	specifies I ² C device address
[24]	RW	0	tsif_cfg_data_in	specifies I ² C address is 8-bit/16-bit
[23:8]	RW	0	tsif_cfg_data_in	specifies I ² C address
[7:0]	RW	0	tsif_cfg_data_in	specifies 8-bit data

5.5 PM Control

This block implements power management. The chip works in three PCIe based power states (1) D0, (2) D3 Hot and (3) D3 Cold.

There is NO power plane separation between Vaux and VCC. In D3 Cold, the chip VCC should be powered from Vaux to support remote wake up.

Further power save is achieved through disabling the blocks which are not selected. A set of register bits, Port_dis_reg[7:0], are provided to disable each block independently. Port_dis_reg is mapped to BAR4 + 0x69 and can access through all functions and its bit map is given below

Register Bit	Control	Description
port_dis_reg[0]	pp_disable	1: Disables Parallel Port
port_dis_reg[1]	Serial Port transceiver shut down polarity	1: Active Low 0: Active High
port_dis_reg[2]	Serial Port transceiver shut down enable	1: Enables transceiver shut down when in power save mode 0: disables transceiver shut down
port_dis_reg[3]	sp1_disable	1 : Disables Serial Port 1
port_dis_reg[4]	sp2_disable	1 : Disables Serial Port 2
port_dis_reg[5]	Reserved	Reserved
port_dis_reg[6]	Reserved	Reserved
port_dis_reg[7]	disp_disable	1 : Reserved

5.6 Cascade Interface

Cascade Interface is a generic IO expansion bus that is based on ASIX proprietary interface protocol. The cascade interface allows interconnecting any ASIX device supporting the cascade interface protocol.

A standalone MCS9922 device supports up to 2 serial ports over PCIe. When a MCS9922 device is interconnected through MCS9900 device cascade interface, the number of peripheral ports can be increased. The combined MCS9922 and MCS9900 devices are serviced through a single PCIe on the primary MCS9900, and the ports can be expanded using one of the following configurations.

- 6 serial ports
- 4 serial ports and 1 parallel ports

In cascaded configuration, MCS9900 chip works as primary and MCS9922 as secondary. The primary chip implements 4-function PCIe endpoint. The PCIe core of secondary chip is disabled. Only cascade and serial port logic is active in secondary chip

The cascade interface also allows connecting any other chip that's designed as per this interface. When a non MCS9900 chip is connected, functions 0, 1 and 2 are used by primary and functions 3 and 4 are available to be used by secondary chip.

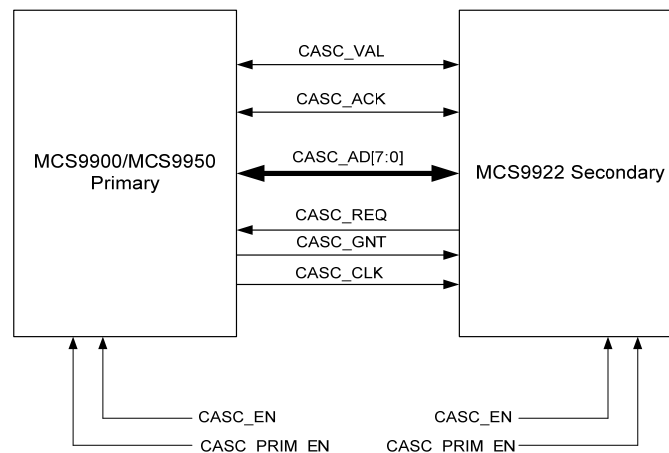

Cascade Interface between Primary and Secondary Devices

In cascade mode, the PCIe endpoint interface is available through the primary MCS9900 device only. The PCIe is disabled on the MCS9922 cascaded secondary device and its access is limited through the cascade interface only. The primary MCS9900 implements a 4-function PCIe endpoint such that each of these 4 functions serve two serial port, one from primary chip and the other from secondary chip. The following tables list the functions and the corresponding BAR mapping.

BAR Mapping for 6-Serial mode PCIe functions

BAR	Function 0	Function 1	Function 2	Function 3
BAR0	SP1 I/O	SP2 I/O	SP3 I/O	SP4 I/O
BAR1	SP1 Mem	SP2 Mem	SP3 Mem	SP4 Mem
BAR2	-	-	-	-
BAR3	SP5 I/O	SP6 I/O	-	-
BAR4	SP5 Mem	SP6 Mem	-	-
BAR5	GPIO/I2C	GPIO/I2C	-	GPIO/I2C

BAR Mapping for 4-Serial 1-Parallel mode PCIe functions

BAR	Function 0	Function 1	Function 2
BAR0	SP1 I/O	SP2 I/O	PP1 I/O
BAR1	SP1 Mem	SP2 Mem	PP1 I/O
BAR2	-	-	PP1 Mem
BAR3	SP3 I/O	SP4 I/O	-
BAR4	SP3 Mem	SP4 Mem	-
BAR5	GPIO/I2C	GPIO/I2C	-

BAR Mapping for 2 Serial & Other Secondary device mode PCIe functions

BAR	Function 0	Function 1	Function 2	Function 3
BAR0	SP1 I/O	SP2 I/O	Secondary chip	Secondary chip
BAR1	SP1 Mem	SP2 Mem	Secondary chip	Secondary chip
BAR2	-	-	Secondary chip	Secondary chip
BAR3	-	-	Secondary chip	Secondary chip
BAR4	-	-	Secondary chip	Secondary chip
BAR5	GPIO/I2C	GPIO/I2C	-	GPIO/I2C

1 Serial & Other Secondary device mode PCIe functions

BAR	Function 0	Function 1	Function 2	Function 3
BAR0	SP1 I/O	-	Secondary chip	Secondary chip
BAR1	SP1 Mem	-	Secondary chip	Secondary chip
BAR2	-	-	Secondary chip	Secondary chip
BAR3	-	-	Secondary chip	Secondary chip
BAR4	-	-	Secondary chip	Secondary chip
BAR5	GPIO/I2C	GPIO/I2C	-	GPIO/I2C

Cascade clock connection

In order to meet timing on cascade interface, it is required to send cascade clock out from primary (through CASC_CLK pin) and bring it back using SCAN_MODE pins to both primary and secondary chips through an external onboard connection. Figure below shows the required connections.

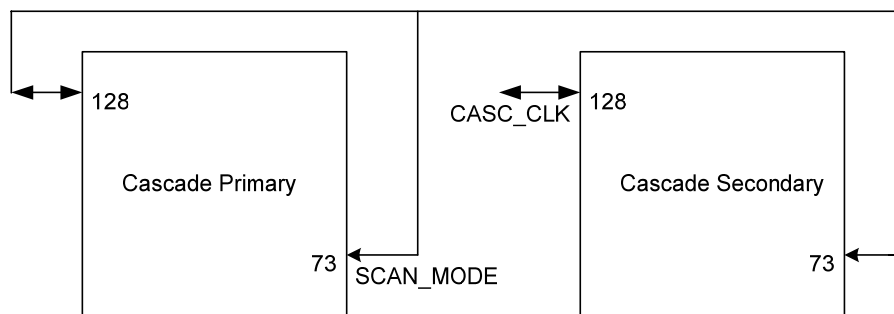

5.7 Clocks and Resets

MCS9922 requires two input clocks. One input clock is sourced from the PCIe connector and the second input clock is sourced from the external crystal. PCIe PHY uses the 100 MHz differential clock from the PCIe connector to generate the internal 125MHz clock. Clock from crystal is used to generate clocks for serial ports.

Crystal Requirement

MCS9922 requires one crystal. This crystal is used to generate serial port clocks. Preferable input frequency is 30 MHz because it allows generating the serial port clock frequency of 96 MHz.

Crystal	Frequency
For Serial Ports	30 MHz

Internal PLLs

MCS9922 uses two PLLs to generate the necessary internal clocks for the device operation. The usage of the PLLs is listed in the following Table.

PLL	Input Frequency	Output Frequency	Used By
PLL1	30 MHz	96 MHz	Serial Port

POR Cell

A POR Cell is used to isolate reset of EEPROM from PCIe reset. It is observed that some PCIe hosts issue multiple PCIe resets. EEPROM read starts automatically on power up. If PCIe reset is used for EEPROM state machines, it causes abrupt resets to EEPROM state machine and may cause it to hang. To avoid this, EEPROM logic is being reset on power-on only. PCIe resets do not affect EEPROM logic.

Side effect of this is that EEPROM logic and the register set that's loaded from EEPROM holds the values till power cycle. If there is a change in EEPROM or EEPROM data, it is required to power cycle in order to get the new values.

5.8 GPIO

There are 8 General Purpose Input/Output pins. All the GPIO pins are interrupt capable. Each GPIO can be configured independent of all other GPIO. The GPIOs allow data input and IRQ generation.

The GPIO Interface register layout can be configured so that the direction and level of each I/O can be configured using either a single register for all I/Os, or discrete registers for each I/O.

Extended Modes through EEPROM

MCS9922 can be configured using external EEPROM, Few such configurations are listed below.

MCS9922 Possible Product Configuration	EEPROM Required?	Mode Selection at System Level?
1 Serial Port	Yes	No
2 Serial Ports	No	No

6 EEPROM Contents Layout

MCS9922 requires an I²C EEPROM (in 16 bit organization mode) for configuring various sub configurations and device parameters.

EEPROM Address	Parameter	MCS9922 (2S)
0	Signature ID_F0[7:0]	10
1	Signature ID_F0[15:8]	97
2	Vendor ID_F0[7:0]	10
3	Vendor ID_F0[15:8]	97
4	Device ID_F0[7:0]	22
5	Device ID_F0[15:8]	99
6	Revision ID	00
7	Programmable IF_F0	02
8	Sub Class Code_F0	00
9	Class Code_F0	07
10	Sub System Vendor ID_F0[7:0]	00
11	Sub System Vendor ID_F0[15:8]	A0
12	Sub System Device ID_F0[7:0]	00
13	Sub System Device ID_F0[15:8]	10
14	PM_Cap_F0[7:0]	0F
15	PM_Cap_F0[15:8]	06
16	Extended capabilities F0[7:0]	01
17	Extended capabilities F0[15:8]	00
18	Device Capabilities F0[7:0]	02
19	Device Capabilities F0[15:8]	83
20	Link_Capabilities F0[7:0]	07
21	msi_and_clk_pwr_mgmt_en F0[7:0]	19
22	Interrupt pin F0	01
23	Vendor ID_F1[7:0]	10
24	Vendor ID_F1[15:8]	97
25	Device ID_F1[7:0]	22
26	Device ID_F1[15:8]	99
27	Programmable IF_F1	02
28	Sub Class Code_F1	00
29	Class Code_F1	07
30	Sub System Vendor ID_F1[7:0]	00
31	Sub System Vendor ID_F1[15:8]	A0
32	Sub System Device ID_F1[7:0]	00
33	Sub System Device ID_F1[15:8]	10
34	PM_Cap_F1[7:0]	0F
35	PM_Cap_F1[15:8]	06
36	Extended capabilities F1[7:0]	01
37	Extended capabilities F1[15:8]	00
38	Device Capabilities F1[7:0]	02
39	Device Capabilities F1[15:8]	83



MCS9922

PCIe to Dual Serial Controller

EEPROM Address	Parameter	MCS9922 (2S)
40	Link_Capabilities F17:0]	07
41	msi_and_clk_pwr_mgmt_en F1[7:0]	19
42	Interrupt pin F1	02
43	Vendor ID_F2[7:0]	FF
44	Vendor ID_F2[15:8]	FF
45	Device ID_F2[7:0]	FF
46	Device ID_F2[15:8]	FF
47	Programmable IF_F2	00
48	Sub Class Code_F2	00
49	Class Code_F2	00
50	Sub System Vendor ID_F2[7:0]	00
51	Sub System Vendor ID_F2[15:8]	00
52	Sub System Device ID_F2[7:0]	00
53	Sub System Device ID_F2[15:8]	00
54	PM_Cap_F2[7:0]	00
55	PM_Cap_F2[15:8]	00
56	Extended capabilities F2[7:0]	00
57	Extended capabilities F215:8]	00
58	Device Capabilities F2[7:0]	00
59	Device Capabilities F2[15:8]	00
60	Link_Capabilities F2[7:0]	00
61	msi_and_clk_pwr_mgmt_en F2[7:0]	00
62	Interrupt pin F2	00
63	Vendor ID_F3[7:0]	FF
64	Vendor ID_F3[15:8]	FF
65	Device ID_F3[7:0]	FF
66	Device ID_F3[15:8]	FF
67	Programmable IF_F3	00
68	Sub Class Code_F3	00
69	Class Code_F3	00
70	Sub System Vendor ID_F3[7:0]	00
71	Sub System Vendor ID_F3[15:8]	00
72	Sub System Device ID_F3[7:0]	00
73	Sub System Device ID_F3[15:8]	00
74	PM_Cap_F3[7:0]	00
75	PM_Cap_F3[15:8]	00
76	Extended capabilities F3[7:0]	00
77	Extended capabilities F3[15:8]	00
78	Device Capabilities F3[7:0]	00
79	Device Capabilities F3[15:8]	00
80	Link_Capabilities F3[7:0]	00
81	msi_and_clk_pwr_mgmt_en F3[7:0]	00
82	Interrupt pin F3	00
83	Vendor ID_F4[7:0]	FF
84	Vendor ID_F4[15:8]	FF
85	Device ID_F4[7:0]	FF

EEPROM Address	Parameter	MCS9922 (2S)
86	Device ID_F4[15:8]	FF
87	Programmable IF_F3	00
88	Sub Class Code_F3	00
89	Class Code_F3	00
90	Sub System Vendor ID_F4[7:0]	00
91	Sub System Vendor ID_F4[15:8]	00
92	Sub System Device ID_F4[7:0]	00
93	Sub System Device ID_F4[15:8]	00
94	PM_Cap_F4[7:0]	00
95	PM_Cap_F4[15:8]	00
96	Extended capabilities F4[7:0]	00
97	Extended capabilities F4[15:8]	00
98	Device Capabilities F4[7:0]	00
99	Device Capabilities F4[15:8]	00
100	Link_Capabilities F4[7:0]	00
101	msi_and_clk_pwr_mgmt_en F4[7:0]	00
102	Interrupt pin F4	00
103	INTA Mask register	02
104	INTB Mask Register	04
105	INTC Mask Register	00
106	INTD Mask Register	00
107	Port Disable Register	02
108	Reserved	14
109	Serial port1 Function number	00
110	Serial port2 Function number	01
111	Serial port3 Function number	02
112	Serial port4 Function number	03
113	Reserved	00
114 to 170	bar3,bar4 incase of 3rd party modes	-

7 Electrical Specifications

Absolute Maximum Ratings

Symbol	Description	Rating	unit
V _{CK}	1.2V Digital Power Supply	-0.3 to 1.44	V
V _{CC12A}	1.2V Analog Power Supply	-0.3 to 1.44	V
V _{CC33IO}	3.3V Digital Power Supply	-0.3 to 4.0	V
V _{CC33A}	3.3V Analog Power Supply	-0.3 to 4.0	V
T _{stg}	Storage temperature	-40 to 150	°C
T _o	Operating temperature	0 to 85	°C
T _j	Junction temperature	0 to 125	°C
ESD HBM	(MIL-STD 883E Method 3015-7 Class 2)	2000	V
ESD MM	(JEDEC EIA/JESD22 A115-A)	200	V
CDM	(JEDEC JESD22 C101-A)	500	V
θ _{JA}	Thermal Resistance of Junction to Ambient	52.7	C/W
θ _{JC}	Thermal Resistance of Junction to Case	17.8	C/W
Ψ _{JT}	Junction to Top of the Package Characterization Parameter	0.54	C/W

C/W – °C per Watt , For Still Air Condition

Recommended Operating Conditions

Symbol	Description	Min	Typ	Max	units
VCCK	1.2V Digital Power Supply	1.08	1.2	1.32	V
VCC12A	1.2V Analog Power Supply	1.08	1.2	1.32	V
VCC33IO	3.3V Digital Power Supply	2.97	3.3	3.63	V
VCC33A	3.3V Analog Power Supply	2.97	3.3	3.63	V
$I_{1.2VD}$	Current in 1.2V Digital Power Supply		65		mA
$I_{1.2VA}$	Current in 1.2V Analog Power Supply		40		mA
$I_{3.3VD}$	Current of 3.3V Digital Power Supply		20		mA
$I_{3.3VA}$	Current in 3.3V Analog Power Supply		75		mA

8 Mechanical Dimensions

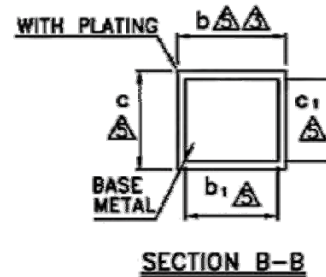
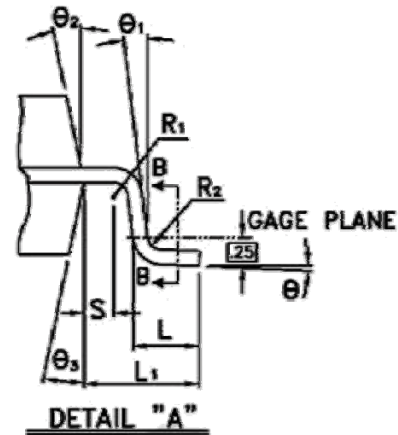
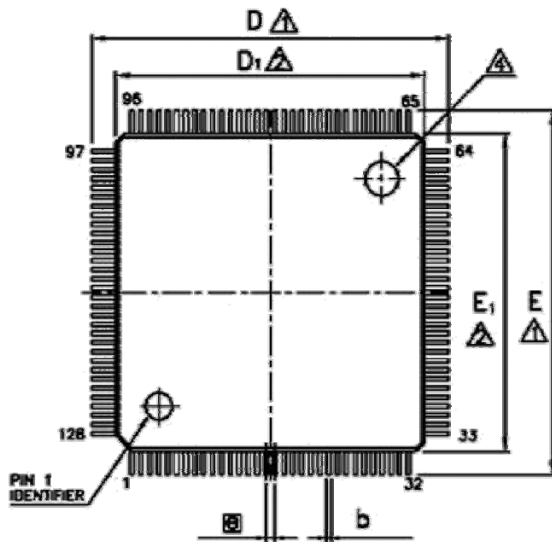

Symbol	Dimension in mm		
	Min	Nom	Max
A	—	—	1.60
A ₁	0.05	—	—
A ₂	1.35	1.40	1.45
b	0.13	0.18	0.23
b ₁	0.13	0.15	0.19
c	0.09	—	0.20
c ₁	0.09	—	0.16
D	15.85	16.00	16.15
D ₁	13.90	14.00	14.10
E	15.85	16.00	16.15
E ₁	13.90	14.00	14.10
⌀	0.40 BSC		
L	0.45	0.60	0.75
L ₁	1.00 REF		
R ₁	0.08	—	—
R ₂	0.08	—	0.20
S	0.20	—	—
θ	0°	3.5°	7°
θ ₁	0°	—	—
θ ₂	12° TYP		
θ ₃	12° TYP		

NOTE :

- ▲ TO BE DETERMINED AT SEATING PLANE ECB.
 - ▲ DIMENSIONS D₁ AND E₁ DO NOT INCLUDE MOLD PROTRUSION. D₁ AND E₁ ARE MAXIMUM PLASTIC BODY SIZE DIMENSIONS INCLUDING MOLD MISMATCH.
 - ▲ DIMENSION b DOES NOT INCLUDE DAMBAR PROTRUSION. DAMBAR CAN NOT BE LOCATED ON THE LOWER RADIUS OF THE FOOT.
 - ▲ EXACT SHAPE OF EACH CORNER IS OPTIONAL.
 - ▲ THESE DIMENSIONS APPLY TO THE FLAT SECTION OF THE LEAD BETWEEN 0.10 mm AND 0.25 mm FROM THE LEAD TIP.
 - ▲ A₁ IS DEFINED AS THE DISTANCE FROM THE SEATING PLANE TO THE LOWEST POINT OF THE PACKAGE BODY.
7. CONTROLLING DIMENSION : MILLIMETER.
 B. REFERENCE DOCUMENT : JEDEC MS-026.



Revision History

Revision	Date	Comment
1.0	20 July 2010	Initial release
2.00	2011/08/05	<ol style="list-style-type: none">1. Changed to ASIX Electronics Corp. logo, strings and contact information.2. Added ASIX copyright legal header information.3. Modified the Revision History table format.4. Updated the block diagram in Section 1.1.



**4F, No. 8, Hsin Ann Rd., HsinChu Science Park,
HsinChu, Taiwan, R.O.C.**

TEL: 886-3-5799500

FAX: 886-3-5799558

Sales Email: sales@asix.com.tw

Support Email: support@asix.com.tw

Web: <http://www.asix.com.tw>