

MODULAR CHECK VALVES

MCV SERIES

積層型止逆閥

◆ MODEL 型 式

MCV-02

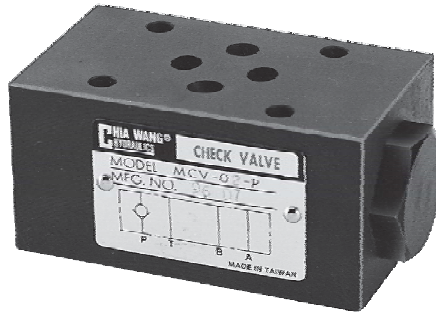

◆ FEATURES

- MCV series modular check valves can be used for all the ports including the "P" port, "T" port, "B" port, or "W" port, etc..
- Casting iron valve bodies are provided strength and durability for longer life.
- Internal hardened steel components also provide durable life.

- 特 點
- MCV系列積層型止逆閥 P孔、T孔、A孔、B孔、W孔等...均可使用。
- 閥本體鑄鐵強度夠且耐久性，壽命長。
- 內部硬鋼原件提高產品壽命。

◆ SPECIFICATIONS 規 格

Model Number 型式號碼	Maximum Pressure 最大壓力 bar	Connecting PT 適用管徑	Maximum Flow 最大流量 lpm	Weight 重量 Kg
MCV-02-P, T, A,B,C,D	315 (4500 psi)	1/4"	40 (10.58 gpm)	1.0 (2.2 lbs)
MCV-02-W				1.2 (2.6 lbs)
Fluid Type 流體型式		ISO VG 32, 46, 68		
Viscosity 黏性 cSt		10~400 (59~1854 SSU)		
Operating Temperature 操作溫度 °C		-15~70 (-5~158°F)		
Contamination Level 污染標準		$\beta_{10} \geq 75$, Under NAS Class 12, 25 μ		
Surface Treatment 表面處理		Zinc Phosphate Compound 鋅 磷酸鹽 化合物		

- All of with Screws it's Cent meter Size and If required Inch Size
所附螺絲皆為公制標準規格品，若需英制螺絲請另外備註說明。

◆ HOW TO ORDER 編號說明

1	2	3	4	5
MCV	02	P	1	20

- 1 VALVE SERIES** 系列名稱
MCV=Modular Check Valve

- 2 SUBPLATE MOUNTING SIZE:** 稱呼口徑
02 = 1/4"(6mm)
ISO CETOP3
DIN NG 6
NFPA D03

- 3 ACTION FORM** 動作形式

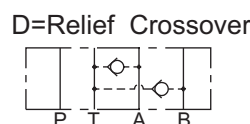
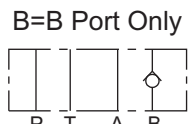
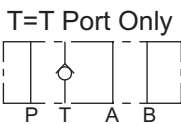
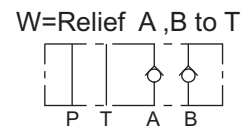
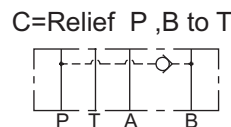
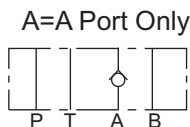
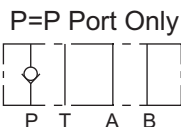

- 4 SPRING PRESSURE** 開啓力

1. 0.5 (bar)
2. 2.5 (bar)
3. 4 (bar)

- 5 DESIGN NO** 設計編號

◆ PERFORMANCE 性能

Test Conditions 測試條件

Oil Temperature 油溫度: 50°C(122°F)

Viscosity 黏度: 35 cSt (163 SSU)

MCV-02

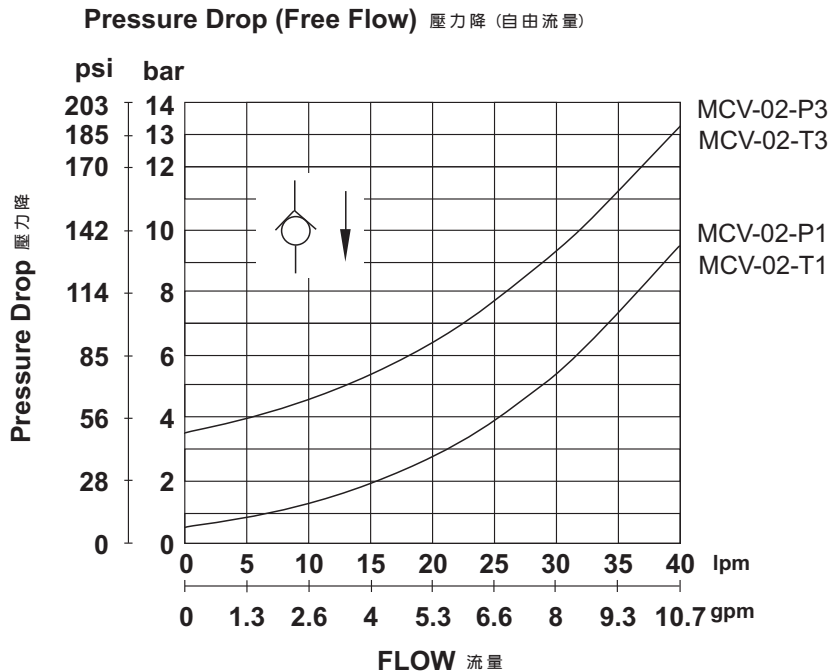
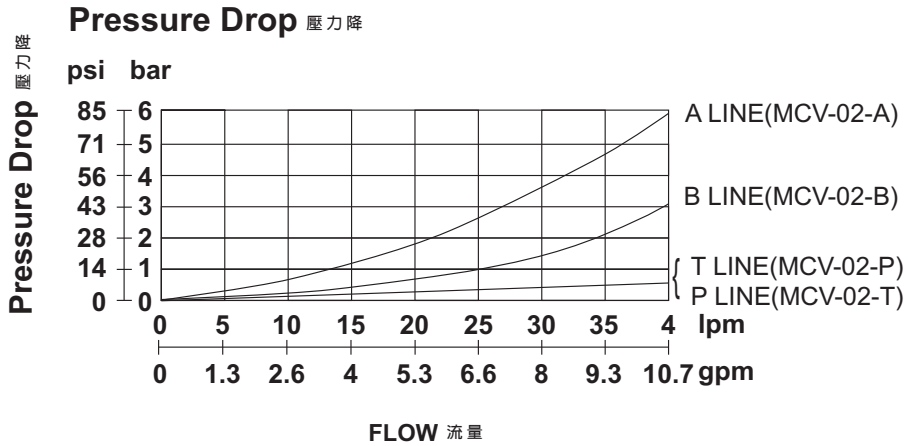

MODULAR CHECK VALVES

MCV SERIES

積層型止逆閥

◆ DIMENSIONS 外型尺寸圖
MCV-02-P. T. A. B. C

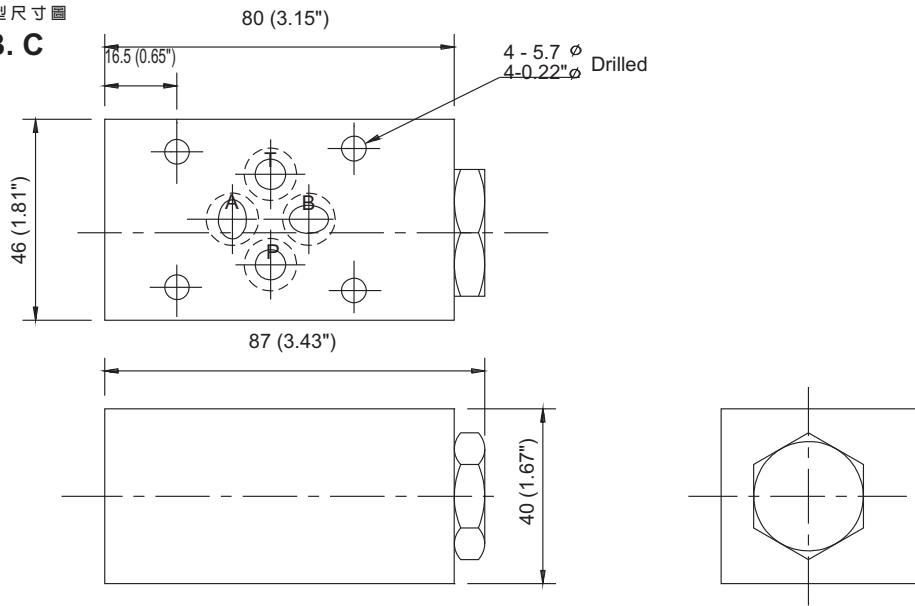

MCV-02-D

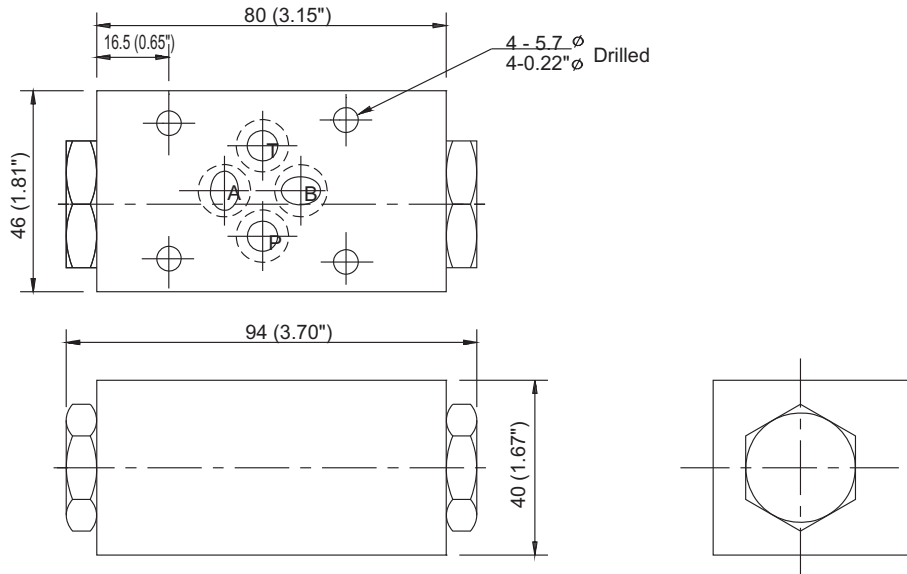

MCV-02-W

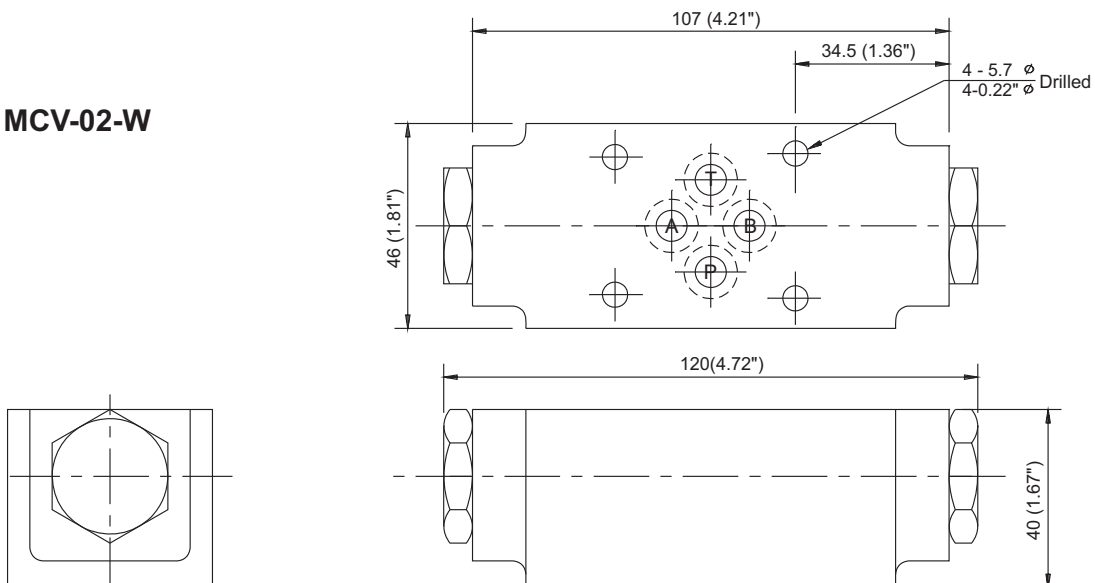

D
MCV

◆ **Mounting Interface** 基座尺寸圖
ISO 4401-AB-03-4-A

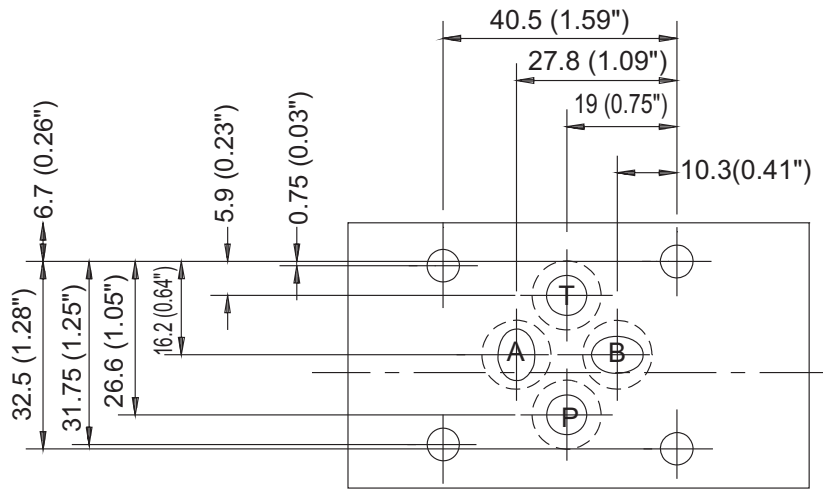

◆ **PARTS LIST OF MCV-02 SERIES** 零件爆炸視圖

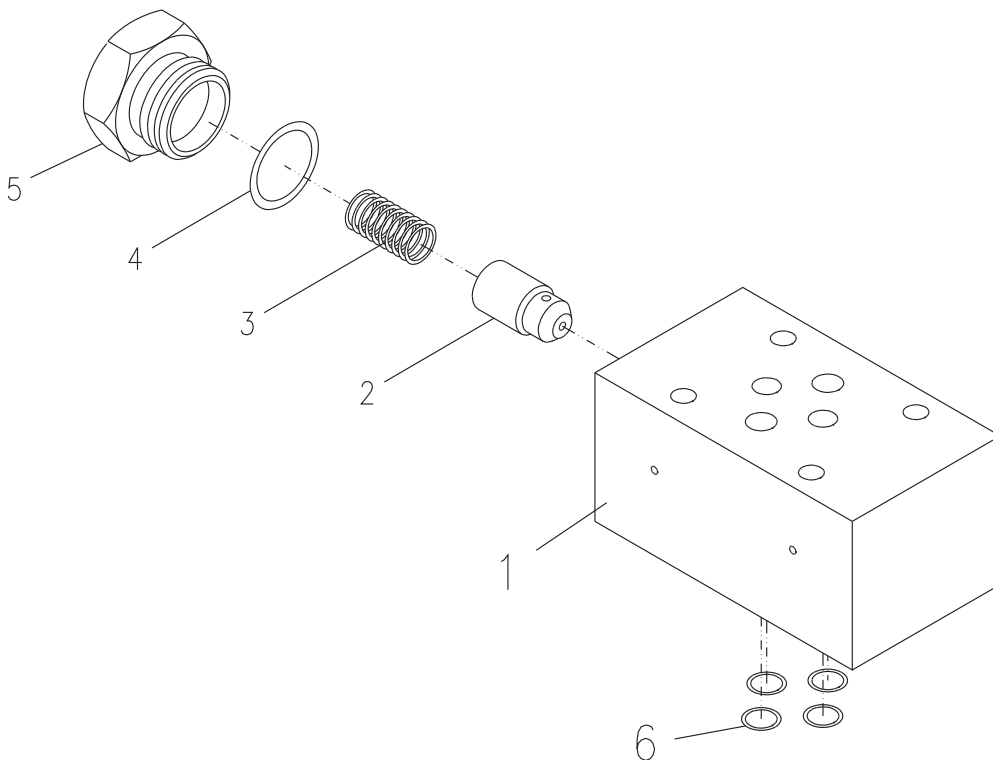

◆ **SEAL KITS** 油封配件

NO	Description	Q'ty	Specification
4	O-ring	1	P18
6	O-ring	4	P9