

## **Engineering Specification**

**Type 22.2 QUXGA-Wide Color TFT/LCD Monitor  
Model Name:MD22292 B0**

**Document Control Number : OEM I-MD22292 B0-03**

**Note:Specification is subject to change without notice. Consequently it is better to contact to International Display Technology before proceeding with the design of your product incorporating this module.**

**Sales Support  
International Display Technology**

## i Contents

- i Contents
- ii Record of Revision
- 1.0 Handling Precautions**
- 2.0 General Description**
  - 2.1 Monitor Characteristics
  - 2.2 Functional Block Diagram
    - 2.2.1 Supported Video I/F Cables
  - 2.3 Deliverables
  - 2.4 Protection of Customer Investment
    - 2.4.1 Application Programs
    - 2.4.2 Hardware And Operating System
- 3.0 Function Elements Descriptions**
  - 3.1 Color TFT-LCD Module
    - 3.1.1 Summary of Type 22.2 QUXGA-Wide Module
    - 3.1.2 Test Conditions
    - 3.1.3 Image Stabilizing Time
  - 3.2 Monitor Interface Card
    - 3.2.1 Summary of the Monitor Interface Card Functions
    - 3.2.2 Geometry Conversion Control
    - 3.2.3 Scan Conversion
    - 3.2.4 Scaling
    - 3.2.5 LED Status Indicator
    - 3.2.6 Debug switch
    - 3.2.7 Power management
  - 3.3 AC/DC Adapter Unit
    - 3.3.1 AC Input
    - 3.3.2 Input Power Harmonic Distortion Content
    - 3.3.3 Input Frequency
    - 3.3.4 DC output
  - 3.4 Switch Card
  - 3.5 Tilt Stand
- 4.0 Mechanical Characteristics**
  - 4.1 Mechanical Drawing
  - 4.2 Weight
  - 4.3 Protective Front Filter
    - 4.3.1 Rigidity
    - 4.3.2 Panel Breakage Test
    - 4.3.3 Non-Glare
  - 4.4 Display Area
    - 4.4.1 Active Area
    - 4.4.2 Pixel Dimension
- 5.0 System Interface**
  - 5.1 Physical Interface
    - 5.1.1 Digital Video Signal Connector
    - 5.1.2 EEDID Data
    - 5.1.3 DC-IN Connector
    - 5.1.4 Connector Location
  - 5.2 Electrical Interface Requirements
  - 5.3 Interface Timings (each DVI input)
  - 5.4 Input Powers

5.4.1 Power Specifications

**6.0 Front of Screen Performance**

6.1 General

6.2 White Luminance

6.2.1 White Luminance Specifications

6.3 Color

6.3.1 Chromaticity

6.3.2 White Balance

6.4 Finger Pressure Distortion

6.5 Gray Scale

6.6 Optical Response Time

6.6.1 Definition

6.6.2 Characteristics

**7.0 EMC Requirements**

7.1 EMI Performance

7.2 Very/Extra Low Frequency Magnetic Field

7.3 Very/Extra Low Frequency Electric Field

**8.0 Environment**

8.1 Temperature and Humidity

8.1.1 Operating Conditions

8.1.2 Shipping Conditions

8.2 Atmospheric Pressure

**9.0 Industry Standards (IEEE, ISO, IEC, and so on)**

**10.0 Backlight Life**

## ii Record of Revision

Date	Document Revision	Page	Summary
November 15,2001	OEM I-MD22292B0-01	All	<p>First Edition for customer Based on Internal Spec. Rev.1.20 as of September 28,2001.</p> <p><b>MD22292B0 :</b> TFT-LCD Color Display Unit with ;</p> <ul style="list-style-type: none"> <li>• Tilt Stand</li> <li>• AC/DC Adapter Unit</li> <li>• AC Line Cord (Selective)</li> </ul> <p><b>MD22292B1 :</b> TFT-LCD Color Display Unit with ;</p> <ul style="list-style-type: none"> <li>• Tilt Stand</li> <li>• AC/DC Adapter Unit</li> <li>• Interface cables for Matrox G200MMS (x2)</li> <li>• Video adapter card Matrox G200MMS custom version</li> <li>• AC Line Cord (Selective)</li> </ul> <p><b>MD22292B2 :</b> TFT-LCD Color Display Unit with;</p> <ul style="list-style-type: none"> <li>• Tilt Stand</li> <li>• AC/DC Adapter Unit</li> <li>• Interface cables for DVI (such as ATI FireGL4)</li> <li>• AC Line Cord (Selective)</li> </ul>
April 2,2002	OEM I-MD22292 B0-02	7 9 10 12 13 14 17,18 19 21-23 24,25 26 31-55 58 59 62	<p>Based on Internal Spec. as of March 18,2002. To update following items.</p> <ul style="list-style-type: none"> <li>• Weight and Physical Size</li> <li>• Supported Video I/F Cables</li> <li>• Supported input video format</li> <li>• Scan Conversion</li> <li>• Scaling</li> <li>• Debug switch</li> <li>• Mechanical Drawing</li> <li>• Weight</li> <li>• Signal Connector Pin Assignment</li> <li>• EEDID Data</li> <li>• EEDID Law Data for Reference</li> <li>• Interface Timings (each DVI input)</li> <li>• Chromaticity</li> <li>• Description for Gray scale</li> <li>• Industry Standards</li> </ul>
April 22,2002	OEM I-MD22292 B0-03	7 9 10	<p>To update Video Interface.</p> <p>To update Deliverables.</p> <p>To update Hardware And Operating System.</p>

## 1.0 Handling Precautions

- Do not exert strong pressure to the surface of the monitor screen. You may break the LCD panel.
- Do not place heavy objects on top of this product. They may damage the monitor.
- Do not touch the monitor screen with your fingers. Fingerprints and oil stains may remain on the screen surface. They are difficult to wipe off.
- The monitor is heavy. Ask the help of others if you cannot carry it by yourself.
- When leaving your office for a long vacation, always unplug the power cords from the main outlet.
- The liquid crystals in the display panel contain several irritants. If the panel is damaged or broken, do not let the liquid come in contact with your skin, eyes, or mouth. If you do come in contact with the liquid, flush the affected part with running water for at least 15 minutes. If any symptom remains, consult a doctor.
- The fluorescent lamp in the liquid crystal display (LCD) contains mercury (50 mg. (0.002 oz.) maximum). Do not place in trash that is disposed of in landfills. Dispose of it as required by local ordinances or regulations.
- The front polarizer can be easily damaged. Take care not to scratch the front surface with any hard or abrasive material. Dust, finger marks, grease etc. can be removed with a soft damp cloth (a small amount of mild detergent can be used on the damp cloth). Do not apply water or detergent directly to the front surface as this may cause staining or damage the electronic components.
- Never use any solvent on the front polarizer or module as this may cause permanent damage.
- Do not open or modify the monitor assembly.
- Continuous operation of the monitor with the same screen content may result in some image sticking. Over 10 hours operation with the same content is not recommended.
- Wipe off water drop immediately. Long contact with water may cause discoloration or spots.
- When the panel surface is soiled, wipe it with absorbent cotton or other soft cloth.

- The information contained herein is presented only as a guide for the applications of our products. No responsibility is assumed by International Display Technology for any infringements of patents or other right of the third parties which may result from its use. No license is granted by implication or otherwise under any patent or patent rights of International Display Technology or others.
- The information contained herein may be changed without prior notice. It is therefore advisable to contact International Display Technology before proceeding with the design of equipment incorporating this product.

## **2.0 General Description**

This is a desktop monitor which uses 56.4 cm (22.2" Type) high resolution color TFT-LCD technology as the display device.

The screen format and electrical interface are intended to support the QUXGA-Wide (3840(H) x 2400(V), 16:10 aspect) screen.

Supported colors are native 16M colors(RGB 8-bit data driver).

Video input signals are DVI x4 (TMDS x4), DVI x2 (TMDS x2), or DVI x1 (TMDS x1) interface compatible.

## 2.1 Monitor Characteristics

The following items are characteristics summary on the table under 25 degree C condition:

CHARACTERISTICS ITEMS	SPECIFICATIONS
Screen Diagonal [cm]	56.4 (22.2 inch)
Pixels H x V	3840(H) x 2400(V)
Screen Active Area [mm]	478.1(H) x 298.8(V)
Pixel Pitch [mm]	0.1245 (per one triad) x 0.1245
Pixel Arrangement	R,G,B Vertical Stripe
Weight [Kg]	11.4 typ. (with stand) 8.82 typ. (without stand)
Physical Size [mm]	547(W) x 399(H) x 76(D) (without stand) 547(W) x 439(H) x 196(D) (with stand)
Display Mode	Dual domain IPS, Normally Black
Supported Color	16M (RGB 8-bit data)
White Luminance [cd/m <sup>2</sup> ]	235 typ.
Contrast Ratio	400 : 1 typ. (in the dark room)
Optical Rise Time [msec]	25 typ.
Optical Fall Time [msec]	25 typ.
White Point (x, y)	0.313, 0.329 Typ.
Viewing Angle Range[deg]	+/- 85 Typ. (Horizontal, Vertical) (15:1 Contrast Ratio) +/- 85 Min. (Horizontal, Vertical) (10:1 Contrast Ratio)
Input Voltage [V DC]	+16 (15.5 to 16.8)
Power Consumption [W]	150 max, 135 typ.
Video Interface	DVI 4 Channels with Two Cables DVI 2 Channels with One Cable DVI 1 Channel with One Cable
Temperature Range [degree C] Operating Storage (Shipping)	0 to +35 -20 to +60
Humidity [%RH]	8 to 80 (Operating / Non-Operating) Max wet bulb temp. 23deg.C, No condensation

## 2.2 Functional Block Diagram

The following diagram shows the functional block of monitor 56.4 cm(Type 22.2) Color TFT-LCD Monitor.

Functional Block Diagram

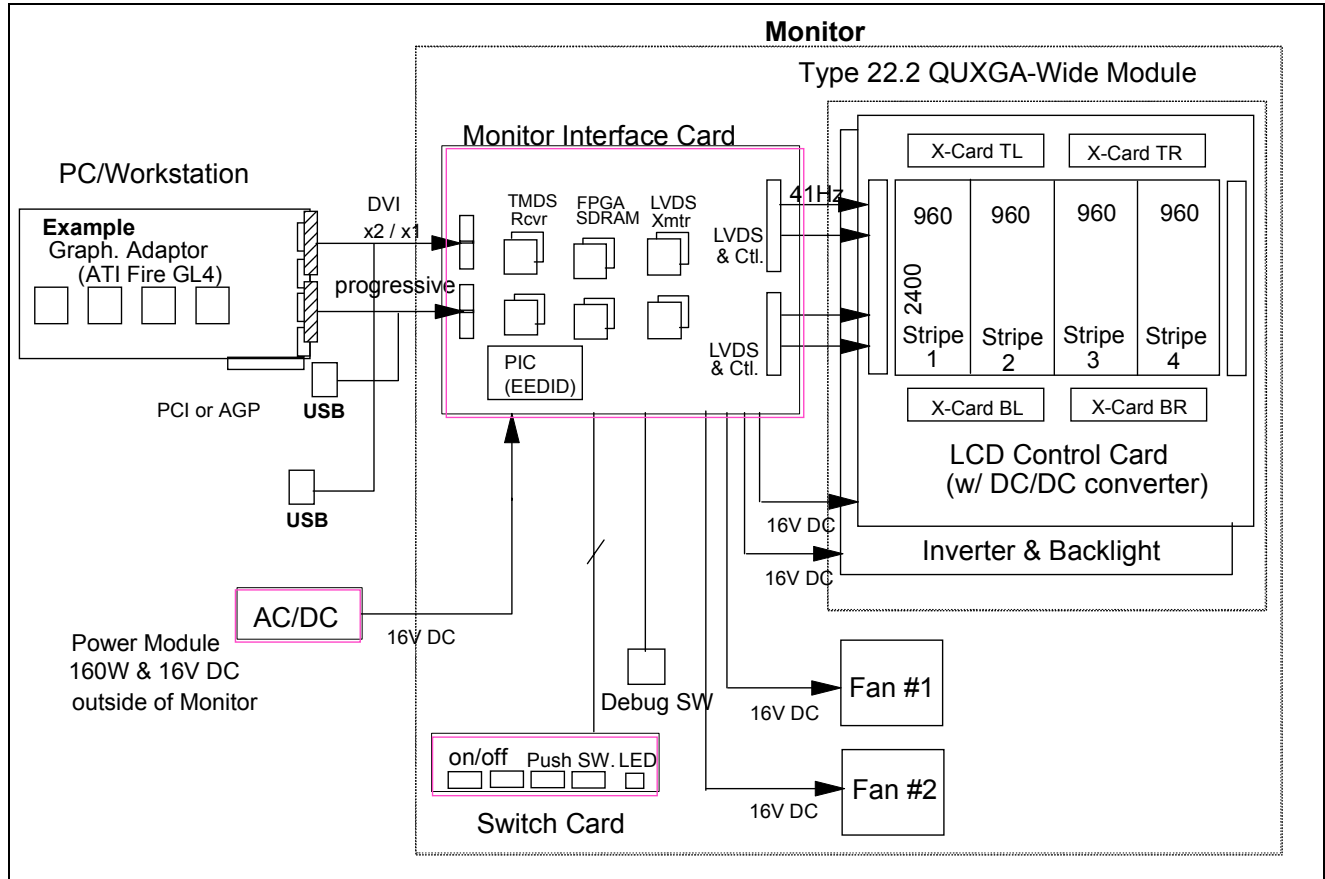



### 2.2.1 Supported Video I/F Cables

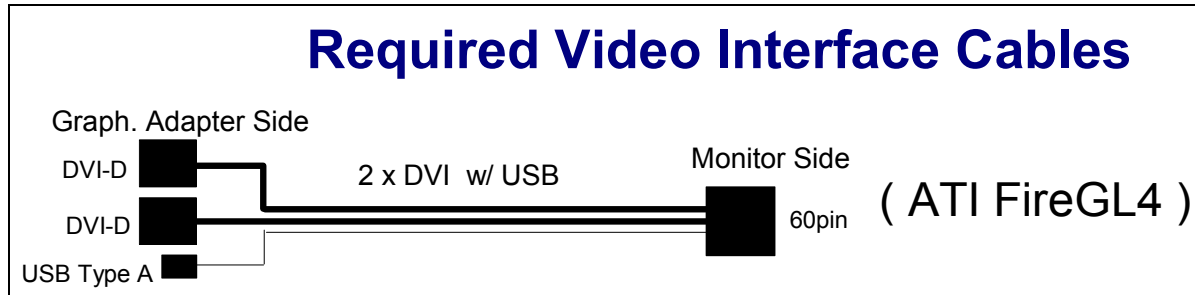

**[Note]** The USB interface is not activated for the initial announced version, and is initially referred to as a 'service interface'. For the current version, it is used to update the monitor firmware. It is also used for transferring the setting parameters from the host PC to the monitor for the monitor built-in Color Adjustment (White Point and Gamma Ramp correction) function.

### 2.3 Deliverables

TFT-LCD Color Display Unit with;

- ▶ Tilt Stand
- ▶ AC/DC Adapter Unit

## 2.4 Protection of Customer Investment

### 2.4.1 Application Programs

Existing programs which conform to published interfaces will continue to run without change.

### 2.4.2 Hardware And Operating System

Graphics Adapter / Video Interface :  
 ATI FireGL4 Video Graphics Card, 2 x DVI w/USB Cable  
 (refer to 2.2.1 Supported Video I/F Cables.)

O/S : Windows 2000, Linux

#### Supported input video format

( in case of max. frequency, refer to 5.3 )

Addressability		DVI Input	Horizontal Frequency (KHz)	Vertical Frequency (Hz)	Dot Clock Frequency (MHz)	Actual Display Resolution
VGA	640x400	ch1	31.5 (N,P)	59.9 (N,P)	25.2	3200x2000
	640x480	ch1	37.9 (N,P)	72.8 (N,P)	31.5	3200x2400
	640x480	ch1	37.5 (N,P)	75.0 (N,P)	31.5	3200x2400
	640x480	ch1	43.3 (N,P)	85.0 (N,P)	36.0	3200x2400
SVGA	800x600	ch1	35.2 (P,N)	56.3 (P,N)	36.0	3200x2400
	800x600	ch1	37.9 (P,N)	60.3 (P,N)	40.0	3200x2400
	800x600	ch1	48.1 (P,N)	72.2 (P,N)	50.0	3200x2400
	800x600	ch1	46.9 (P,N)	75.0 (P,N)	49.5	3200x2400
	800x600	ch1	53.7 (P,N)	85.1 (P,N)	56.3	3200x2400
Matrox VGA	960x1200	ch1	67.3 (P,N)	55.7 (P,N)	71.0	1920x2400
XGA	1024x768	ch1	48.4 (N,P)	60.0 (N,P)	65.0	3072x2304
	1024x768	ch1	56.5 (N,P)	70.1 (N,P)	75.0	3072x2304
	1024x768	ch1	60.0 (P,N)	75.0 (P,N)	78.8	3072x2304
	1024x768	ch1	68.7 (P,N)	85.0 (P,N)	94.5	3072x2304
SXGA	1280x1024	ch1	64.0 (P,N)	60.0 (P,N)	108.0	2560x2048
	1280x1024	ch1	80.0 (P,N)	75.0 (P,N)	135.0	2560x2048
UXGA	1600x1200	ch1	75.0 (P,N)	60.0 (P,N)	162.0	3200x2400
UXGA-Wide	1920x1200	ch1	50.3 (N,P)	40.9 (P,N)	127.2	3200x2400
QUXGA-Wide	(960x2400)x4	ch1,ch2,ch3,ch4	99.2 (P,N)	40.9 (P,N)	104.8	3840x2400
	(1920x1200)x4	ch1,ch2,ch3,ch4	49.6 (P,N)	40.9 (P,N)	104.8	3840x2400
	(1920x2400)x2	ch1, ch2	61.2 (P,N)	25.1 (P,N)	125.0	3840x2400
	(1920x2400)x2	ch1, ch2	58.7 (P,N)	24.1 (P,N)	120.0	3840x2400
	(1920x2400)x2	ch1, ch2	48.9 (P,N)	20.1 (P,N)	100.0	3840x2400
	3840x2400	ch1	31.5 (P,N)	13.0 (P,N)	129.0	3840x2400
	3840x2400	ch1	30.73 (N,P)	12.66 (P,N)	148.0	3840x2400

[Note] : P, N stands for "Positive", "Negative" polarity of incoming timing respectively.

## 3.0 Function Elements Descriptions

### 3.1 Color TFT-LCD Module

The summary of Front of Screen specification of the complete system is shown below.

#### 3.1.1 Summary of Type 22.2 QUXGA-Wide Module

Screen Diagonal [cm]	56.4 (22.2 inch)
Pixels H x V	3840(H) x 2400(V)
Active Area [mm]	478.1(H) x 298.8(V)
Pixel Pitch [mm]	0.1245 x 0.1245
Pixel Arrangement	R,G,B Sub-pixel Vertical Stripe
Display Mode	Dual Domain IPS, Normally Black
Supported Color	16M (RGB 8-bit each)
White Luminance [cd/m <sup>2</sup> ]	235 typ.
Contrast Ratio	400 : 1 typ.(In the Dark room)
Optical Rise+Fall Time [msec]	50 typ.
Color Point (x, y)	0.313, 0.329
Viewing Angle Range[degree]	+/- 85 typ. (Horizontal, Vertical) (10:1 CR)

#### 3.1.2 Test Conditions

1. The backlight on, the brightness control set to maximum.
2. In a dark room
3. At 25 +/- 3 degree C
4. At a nominal input voltage
5. A photometer shall measure an area at the center of LCD that is larger than a single pixel. Viewing direction is normal to the surface of the LCD.
6. Input signal timing listed in typical of "5.3,Interface Timings" .

#### 3.1.3 Image Stabilizing Time

The image will begin to be visible within 3 seconds of application of power and input signals. The image will be stabilized within 10 seconds of application of power and input signals. "stabilized" means that using the unaided eyes, no significant change will occur in terms of the image quality specifications, such as luminance, uniformity, color, and so on. The light output will meet the brightness specifications after 60 minutes of the application of power and input signals.

## 3.2 Monitor Interface Card

The monitor interface card converts TMDS video signals in DVI x4 or DVI x2 interfaces to 8 sets (even/odd x 4) of LVDS signals with image processing for TFT-LCD module.

Two digital video interface connectors are mounted on the monitor interface card and each connector accommodates two DVI video signal sets.

The monitor interface card has an interface to the Switch Card.

### 3.2.1 Summary of the Monitor Interface Card Functions

1. Conversion of data from TMDS to LVDS
2. Geometry conversion
3. Scan conversion
4. Scaling
5. On Screen Display (OSD)
6. LED control ( power and standby )
7. Debug switch support
8. Power management
9. Fan control
10. DDC interface

### 3.2.2 Geometry Conversion Control

The monitor interface card converts following geometry into four 960 x 2400 vertical stripes for TFT-LCD module.

- I. Single image
- II. Two Vertical Stripe images
- III. Four Vertical Stripe images
- IV. Four Tile images

### 3.2.3 Scan Conversion

Since, maximum scan rate of the TFT-LCD is up to 41 Hz, the monitor interface card converts various range of input frequencies into the 41Hz. The monitor interface card also support 20.5Hz to 41Hz up conversion to reduce flicker effect under slow refresh mode.

- I. Down conversion: 56 ~ 85 Hz to 41Hz
- II. Up conversion: 12.7, 13.0 Hz, 20.1, 24.1 Hz, 25.1 Hz, to 41Hz

### 3.2.4 Scaling

The monitor interface card provides a scaling function to fit nonnative resolution images to the screen.

Addressability		Scaling		After Scaling
		H	V	
VGA	640 x 480	x 5	x 5	3200 x 2400
SVGA	800 x 600	x 4	x 4	3200 x 2400
XGA	1024 x 768	x 3	x 3	3072 x 2304
SXGA	1280 x 1024	x 2	x 2	2560 x 2048
UXGA	1600 x 1200	x 2	x 2	3200 x 2400
UXGA-Wide	1920 x 1200	x 2	x 2	3840 x 2400
QUXGA-Wide	3840 x 2400	x 1	x 1	3840 x 2400

### 3.2.5 LED Status Indicator

Indication of states with two LEDs in one LED package.

Power LED	Standby LED	Color *1	Status	Backlight	FAN
Off	Off	---	Monitor power off	Off	Off
On	Off	Green	Normal operation mode	On	On
Off	On	Orange	Standby mode ( no signal )	Off	Off
Off	Flash	Orange(flash-1Hz)	Unsupported signal *2	Off	Off
Off	Flash	Orange(flash-4Hz)	Caution(FAN stops)	Off	Off

**Note \*1:** Color of indicator.

When power LED is ON --> Color will be GREEN

When standby LED is ON --> Color will be ORANGE

**Note \*2:** Display appears black pattern.

Please check Interface timing with tolerance.

### **3.2.6 Debug switch**

Monitor has a debug switch. Once this switch is pressed, the backlight will be on in any cases until power is off by pressing main power switch.  
This is not for users but for problem determination purpose.

Pressing this switch for more than 5 seconds make Monitor enter the debug mode.  
In the debug mode, Monitor displays some debug patterns.

### **3.2.7 Power management**

Monitor incorporates a Power Management Function on the connector card to reduce power consumption.  
Power consumption in power saving mode(no sync.) is

- Less than 15 watts (incl. AC adapter loss)

### 3.3 AC/DC Adapter Unit

The AC/DC Adapter units(P/N 07N2277) provide +16 V DC for the monitor assembly.

Single AC/DC Adapters are required for the monitor.

The AC/DC Adapter has 3 prong, and also PFC(Power Factor Correction) function for Power Line Harmonics.

#### 3.3.1 AC Input

The adapter operates over the entire input voltage range (100 - 240V AC) or automatically selects an appropriate voltage range without manual intervention.

AC input

	Minimum	Maximum	Nominal(Rating)
Low Range	90 V AC	137 V AC	100 - 127 V AC
High Range	180 V AC	265 V AC	200 - 240 V AC

#### 3.3.2 Input Power Harmonic Distortion Content

The harmonic distortion content of the input AC voltage shall not exceed 5 %.

#### 3.3.3 Input Frequency

The input frequency range shall be 50 +/- 3Hz, 60 +/- 3Hz.

#### 3.3.4 DC output

DC output

Connector Pin	Output	Regulation Tolerance (From Nominal)	Pin Maximum Current
Pin 4,5,6	+ 16.0 V	+ 0.8 V / - 0.5 V	10.5 A
Pin 1,2,3	DC Return	-	10.5 A

### **3.4 Switch Card**

The following external controls are provided with Switch Card on Monitor.

- Monitor power on/off
- Brightness up/down
- Enter the Menu of OSD
- LED for indication of Power on/off, Power saving mode, Malfunction.

### **3.5 Tilt Stand**

A Tilt Stand is supplied to allow this monitor to be positioned for optimum viewing.

Tilt Range : 30 Degrees Backwards, 5 Degrees Forward



## 4.0 Mechanical Characteristics

### 4.1 Mechanical Drawing

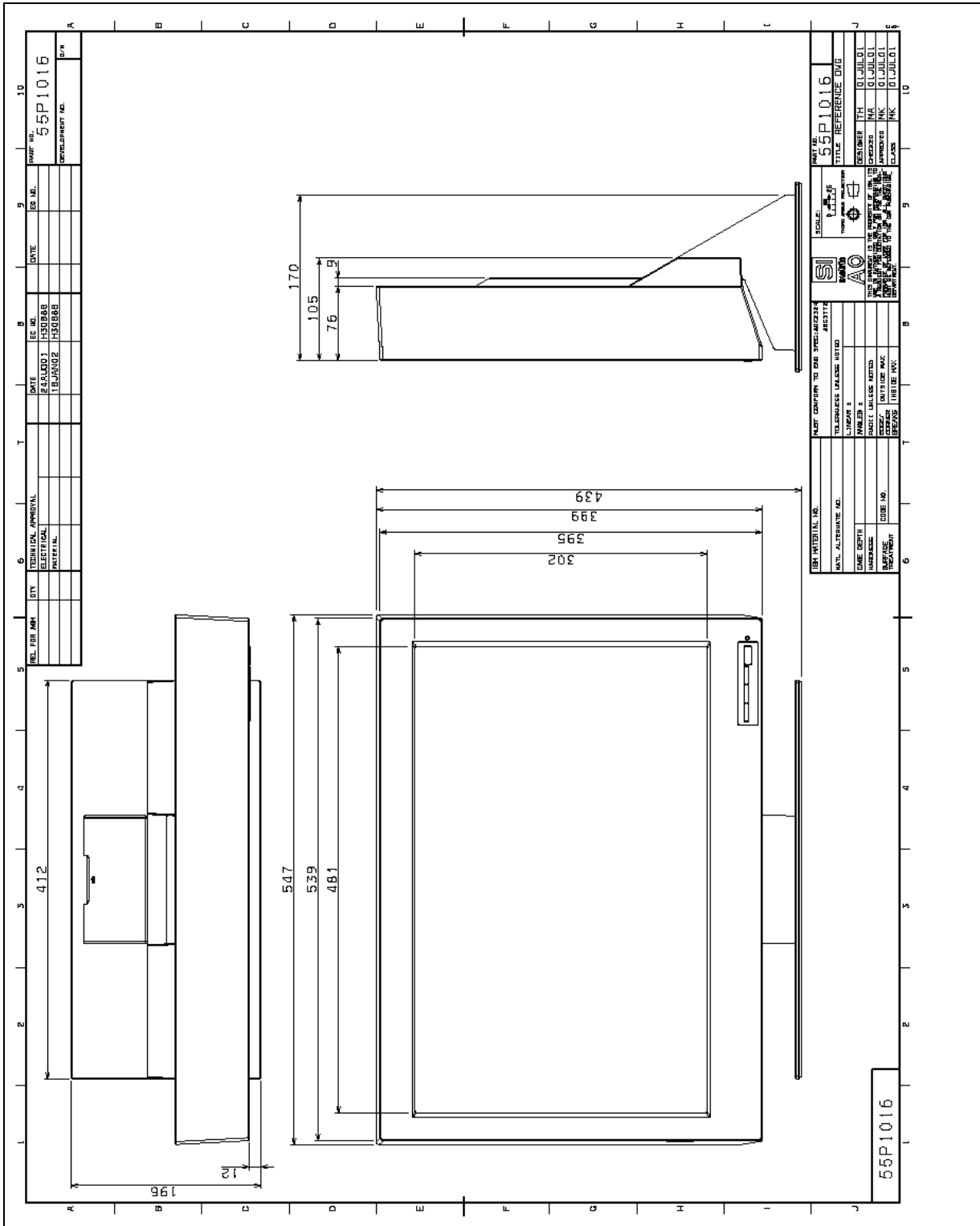

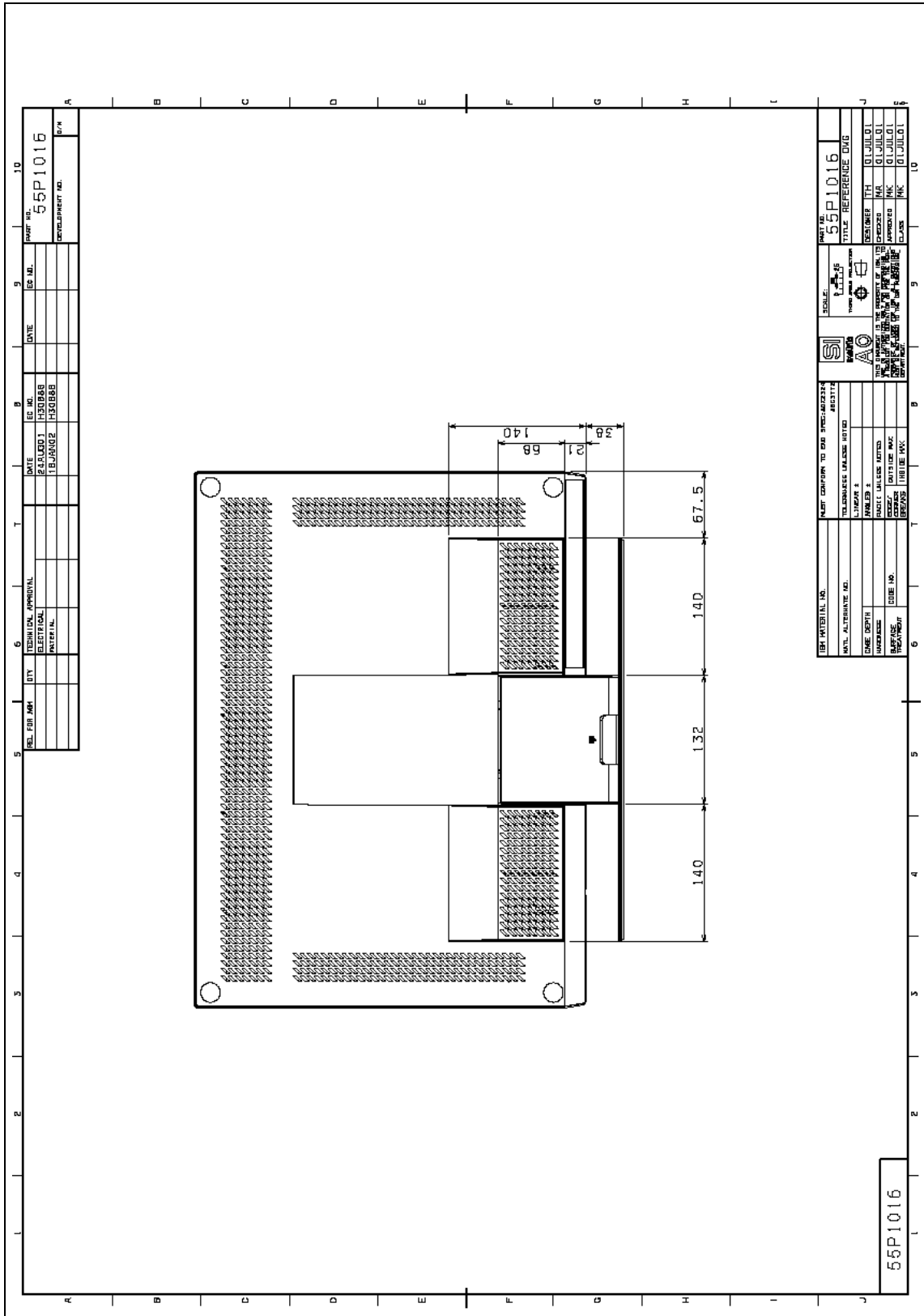

## 4.2 Weight

The weight of monitor is as follows, respectively.

8.82 Kg +/- 5% (without stand)

11.4 Kg +/- 5% (with stand)

## 4.3 Protective Front Filter

The front filter described in this section is included in the LCD module. The film is adhered to the LCD surface to minimize optical interference.

The objective of the filter is:

- to protect the display from impact and prevent any glass from breaking into pieces and scattering.
- to provide good control of glare.

### 4.3.1 Rigidity

The film filter may not be rigid enough to protect the LCD from breakage but it will prevent pieces of the glass from scattering when it is broken. The screen hardness is 3H or greater.

**NOTE:** Refer to JIS Standard K5400 (Method of Rockwell Hardness Test for Plastic).

### 4.3.2 Panel Breakage Test

The module shall pass the following breakage test :

A single impact of 6.8 joules (5 foot-pounds) at the center of the viewing area. The impact shall be from a solid steel sphere with a 50 mm diameter and weighing 535 grams.

The module is deemed acceptable if :

1. There is no exposure of sharp edges of glass.
2. All glass particles are retained by the anti-glare protective panel and do not scatter. Small glass particles (i.e. powder) in the area where the steel ball impacts the panel are excluded from this requirement.

### 4.3.3 Non-Glare

To minimize glare, the black matrix is made of anti glare material. In addition, the film has anti glare treatment. The LCD has a maximum measure of 80 gloss units, measured at 60 degrees' angle of incidence with a VG-2PD Glossmeter(Nippon Denshoku), or equivalent.

## 4.4 Display Area

### 4.4.1 Active Area

Active Area

Height	298.8 [mm]
Width	478.1 [mm]

### 4.4.2 Pixel Dimension

Pixel Dimension

	Height	Width
Pixel	0.1245 [mm]	0.1245 [mm]
Sub-pixel	0.1245 [mm]	0.0415 [mm]

Following figure shows the relationship of the input signals and LCD pixel format image. Odd and even pair of RGB data are sampled at a time.

Color Arrangement

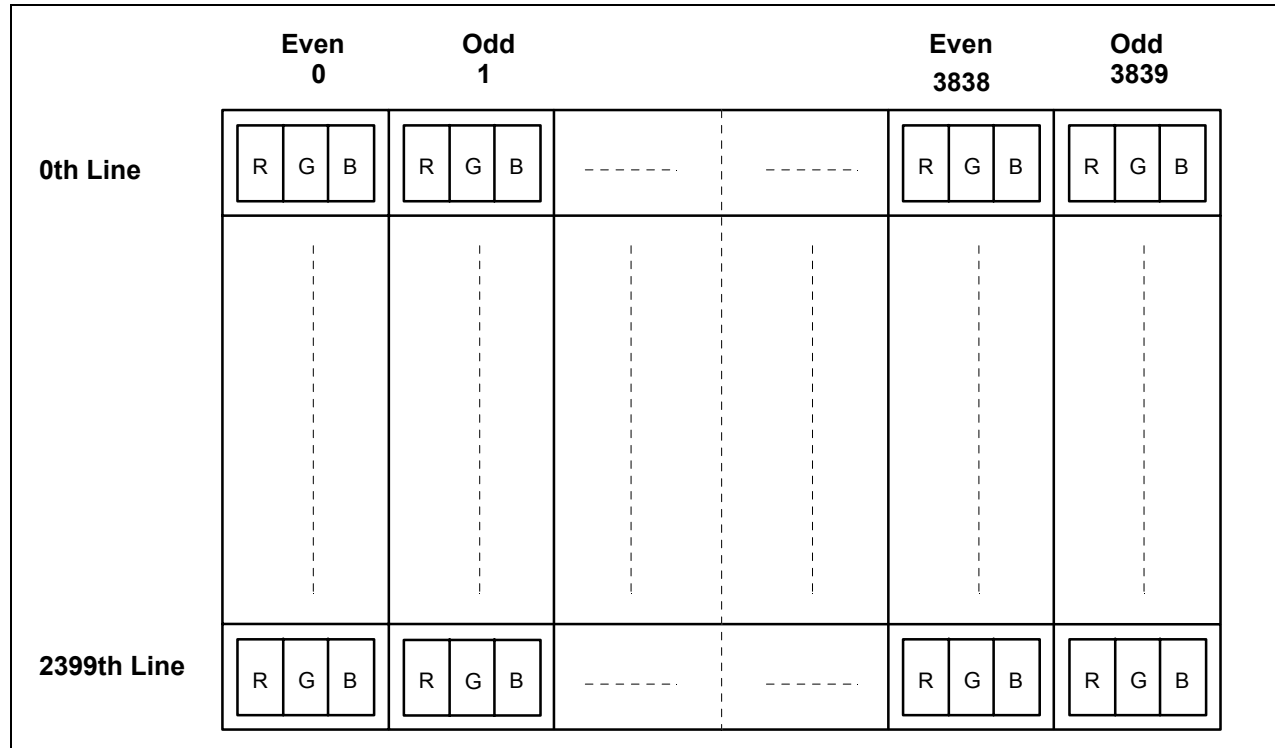

## 5.0 System Interface

### 5.1 Physical Interface

Physical interface is described as for the connector on monitor.

These connectors are capable of accommodating the following signals and will be following components.

#### 5.1.1 Digital Video Signal Connector

Signal Connector A, B

<b>Connector Name / Designation</b>	Signal Connector
<b>Manufacturer</b>	MOLEX
<b>Type / Part Number</b>	70928-2000
<b>Mating Type / Part Number</b>	MOLEX 70929-2000

Signal Connector A Pin Assignment

<b>PIN #</b>	<b>SIGNAL NAME</b>	<b>PIN #</b>	<b>SIGNAL NAME</b>
1	Ground	31	Left TMDS Data 1+ (twisted pair)
2	Not connected	32	Left TMDS Data 1 - (twisted pair)
3	Not connected	33	Left TMDS Clock data+ (twisted pair)
4	Ground	34	Left TMDS Clock data - (twisted pair)
5	+ 5V Power input (MAX 1A)	35	+16V Power output
6	Left SCL (DDC)	36	Hot plug detection
7	Left SDA (DDC)	37	Not connected
8	Not connected	38	Ground
9	Right SDA (DDC)	39	Not connected
10	Right SCL (DDC)	40	Hot plug detection
11	+ 5V Power input (MAX 1A)	41	Not connected
12	Ground	42	Right TMDS Clock data - (twisted pair)
13	Not connected	43	Right TMDS Clock data+ (twisted pair)
14	Not connected	44	Right TMDS Data 1 - (twisted pair)
15	Ground	45	Right TMDS Data 1+ (twisted pair)
16	Right TMDS Data 0+ (twisted pair)	46	Ground
17	Right TMDS Data 0 - (twisted pair)	47	Not connected

18	Right TMDS Data 2+ (twisted pair)	48	Ground
19	Right TMDS Data 2 - (twisted pair)	49	Ground
20	+16V Power output	50	Not connected
21	USB -	51	Not connected
22	Not connected	52	Ground
23	Not connected	53	Not connected
24	Not connected	54	Ground
25	USB +	55	Not connected
26	Ground	56	Not connected
27	Left TMDS Data 2 - (twisted pair)	57	Ground
28	Left TMDS Data 2+ (twisted pair)	58	Ground
29	Left TMDS Data 0 - (twisted pair)	59	Not connected
30	Left TMDS Data 0+ (twisted pair)	60	Ground

**[Note]**

The signals whose name starts with "Left" are used for displaying on Ch-a quarter block in case of Four Vertical Stripe mode or Four Tile mode, or used for displaying on Ch-a half block in case of Two Stripe mode. On the other hand, the signals whose name starts with "Right" are used for displaying on Ch-b quarter block in case of Four Vertical Stripe mode or Four Tile mode, or used for displaying on Ch-b half block in case of Two Stripe mode. (refer to 5.2 for the Electrical Interface Requirement)

**Signal Connector B Pin Assignment**

<b>PIN #</b>	<b>SIGNAL NAME</b>	<b>PIN #</b>	<b>SIGNAL NAME</b>
1	Ground	31	Left TMDS Data 1+ (twisted pair)
2	Not connected	32	Left TMDS Data 1 - (twisted pair)
3	Not connected	33	Left TMDS Clock data+ (twisted pair)
4	Ground	34	Left TMDS Clock data - (twisted pair)
5	+ 5V Power input (MAX 1A)	35	+16V Power output
6	Left SCL (DDC)	36	Hot plug detection
7	Left SDA (DDC)	37	Not connected
8	Ground	38	Ground
9	Right SDA (DDC)	39	Not connected
10	Right SCL (DDC)	40	Hot plug detection
11	+ 5V Power input (MAX 1A)	41	Ground

12	Ground	42	Right TMDS Clock data - (twisted pair)
13	Not connected	43	Right TMDS Clock data+ (twisted pair)
14	Not connected	44	Right TMDS Data 1 - (twisted pair)
15	Ground	45	Right TMDS Data 1+ (twisted pair)
16	Right TMDS Data 0+ (twisted pair)	46	Ground
17	Right TMDS Data 0 - (twisted pair)	47	Not connected
18	Right TMDS Data 2+ (twisted pair)	48	Not connected
19	Right TMDS Data 2 - (twisted pair)	49	Ground
20	+16V Power output	50	Not connected
21	Not connected	51	Not connected
22	Not connected	52	Ground
23	Not connected	53	Not connected
24	Not connected	54	Ground
25	Not connected	55	Not connected
26	Ground	56	Not connected
27	Left TMDS Data 2 - (twisted pair)	57	Ground
28	Left TMDS Data 2+ (twisted pair)	58	Not connected
29	Left TMDS Data 0 - (twisted pair)	59	Not connected
30	Left TMDS Data 0+ (twisted pair)	60	Ground

**[Note]**

The signals whose name starts with "Left" are used for displaying on Ch-c quarter block only in case of Four Vertical Stripe mode or Four Tile mode. On the other hand, the signals whose name starts with "Right" are used for displaying on Ch-d quarter block only in case of Four Vertical Stripe mode or Four Tile mode. (refer to 5.2 for the Electrical Interface Requirements)

### 5.1.2 EEDID Data

Item	Value			Ref.	Remark
	(BIN)	(HEX)	(DEC)		
EISA Manufacture code (IBM=0x24)		24			
EISA Manufacture code, ASCII (IBM=0x4D)		4D			
Product Code			9503		
32bit serial number (1st 8bit)		01			
32bit serial number (2nd 8bit)		01			
32bit serial number (3rd 8bit)		01			
32bit serial number (4th 8bit)		01			
Week of manufacture			1		
Year of manufacture			2001		
EDID Version			1		
EDID Revision			3		
Video Input: Analog=0, Digital=1	1		1		
Video Input: Signal Level	0		0		
Video Input: Setup	0		0		
Video Input: Sync. Input Supported	0000		0		
Max. Horizontal Image Size (cm)			12		
Max. Vertical Image Size(cm)			30		
Gamma Value			2.2		
Feature Support: Stand-By (Supported=1)	1		1		
Feature Support: Suspend	1		1		
Feature Support: Active Off	1		1		
Feature Support: Display Type (01=RGB Monitor)	01		1		
Feature Support: Standard Default Color Space	0		0		
Feature Support: Preferred Timing Mode	0		0		
Feature Support: GTF supported	0		0		
Color Characteristics : Red_x			638		
Color Characteristics : Red_y			340		
Color Characteristics : Green_x			292		
Color Characteristics : Green_y			611		
Color Characteristics : Blue_x			146		
Color Characteristics : Blue_y			85		
Color Characteristics : White_x			313		
Color Characteristics : White_y			329		
Established Timing I : 720x400 @ 70Hz	0		0		
Established Timing I : 720x400 @ 88Hz	0		0		
Established Timing I : 640x480 @ 60Hz	1		1		
Established Timing I : 640x480 @ 67Hz	0		0		
Established Timing I : 640x480 @ 72Hz	1		1		
Established Timing I : 640x480 @ 75Hz	1		1		
Established Timing I : 800x600 @ 56Hz	1		1		
Established Timing I : 800x600 @ 60Hz	1		1		
Established Timing II : 800x600 @ 72Hz	1		1		
Established Timing II : 800x600 @ 75Hz	1		1		
Established Timing II : 832x624 @ 75Hz	0		0		
Established Timing II : 1024x768 @ 87Hz	0		0		
Established Timing II : 1024x768 @ 60Hz	1		1		
Established Timing II : 1024x768 @ 70Hz	1		1		
Established Timing II : 1024x768 @ 75Hz	1		1		
Established Timing II : 1280x1024 @ 75Hz	1		1		
Established Timing III : 1152x870 @ 75Hz	0		0		



Item	Value			Ref.	Remark
	(BIN)	(HEX)	(DEC)		
Standard Timing 1 : Horizontal active pixels (256-2288 pixel)			640		
Standard Timing 1 : Image Aspect ratio	01		1		04:03
Standard Timing 1 : Refresh Rate (Hz)			85		
Standard Timing 2 : Horizontal active pixels (256-2288 pixel)			800		
Standard Timing 2 : Image Aspect ratio	01		1		04:03
Standard Timing 2 : Refresh Rate (Hz)			85		
Standard Timing 3 : Horizontal active pixels (256-2288 pixel)			1024		
Standard Timing 3 : Image Aspect ratio	01		1		04:03
Standard Timing 3 : Refresh Rate (Hz)			85		
Standard Timing 4 : Horizontal active pixels (256-2288 pixel)			1280		
Standard Timing 4 : Image Aspect ratio	10		2		05:04
Standard Timing 4 : Refresh Rate (Hz)			60		
Standard Timing 5 : Horizontal active pixels (256-2288 pixel)			1600		
Standard Timing 5 : Image Aspect ratio	01		1		04:03
Standard Timing 5 : Refresh Rate (Hz)			60		
Standard Timing 6 : Horizontal active pixels (256-2288 pixel)			1920		
Standard Timing 6 : Image Aspect ratio	11		3		16:09
Standard Timing 6 : Refresh Rate (Hz)			60		
Standard Timing 7 : Horizontal active pixels (256-2288 pixel)			256		
Standard Timing 7 : Image Aspect ratio	0		0		
Standard Timing 7 : Refresh Rate (Hz)			61		
Standard Timing 8 : Horizontal active pixels (256-2288 pixel)			256		
Standard Timing 8 : Image Aspect ratio	0		0		
Standard Timing 8 : Refresh Rate (Hz)			61		
Detailed Timing 1 : Pixel clock (MHz)			14800		3840x2400@12.7Hz
Detailed Timing 1 : Horizontal Active (pixels, 12bit)			3840		
Detailed Timing 1 : Horizontal Blanking (pixels, 12bit)			976		
Detailed Timing 1 : Vertical Active (pixels, 12bit)			2400		
Detailed Timing 1 : Vertical Blanking (pixels, 12bit)			18		
Detailed Timing 1 : Horizontal Sync. Offset (pixels, 10bit)			104		
Detailed Timing 1 : Horizontal Sync Pulse Width (pixels, 10bit)			384		
Detailed Timing 1 : Vertical Sync Offset (lines, 6bit)			1		
Detailed Timing 1 : Vertical Sync Pulse Width (lines, 6bit)			3		
Detailed Timing 1 : Horizontal Image Size (mm, 12bit)			480		
Detailed Timing 1 : Vertical Image Size (mm, 12bit)			300		
Detailed Timing 1 : Horizontal Border (pixels)			0		
Detailed Timing 1 : Vertical Border (liness)			0		
Detailed Timing 1 : Flags	00011100	1C	28		Polarity : VS+, HS-
Detailed Timing 2 : Pixel clock (MHz)			12337		1920*2400@20.1Hz
Detailed Timing 2 : Horizontal Active (pixels, 12bit)			1920		
Detailed Timing 2 : Horizontal Blanking (pixels, 12bit)			608		
Detailed Timing 2 : Vertical Active (pixels, 12bit)			2400		
Detailed Timing 2 : Vertical Blanking (pixels, 12bit)			28		
Detailed Timing 2 : Horizontal Sync. Offset (pixels, 10bit)			104		
Detailed Timing 2 : Horizontal Sync Pulse Width (pixels, 10bit)			200		
Detailed Timing 2 : Vertical Sync Offset (lines, 6bit)			1		
Detailed Timing 2 : Vertical Sync Pulse Width (lines, 6bit)			3		
Detailed Timing 2 : Horizontal Image Size (mm, 12bit)			240		
Detailed Timing 2 : Vertical Image Size (mm, 12bit)			300		
Detailed Timing 2 : Horizontal Border (pixels)			0		
Detailed Timing 2 : Vertical Border (liness)			0		
Detailed Timing 2 : Flags	00011100	1C	28		Polarity : VS+, HS-
Detailed Timing 3 : Descriptor Flag (2byte)			0		
Detailed Timing 3 : Flag (1byte)			0		
Detailed Timing 3 : Data Tag (0xFD=Monitor Range Limits)		FD			
Detailed Timing 3 : Min Vertical rate (Hz, use in interlace mode)			9		
Detailed Timing 3 : Max Vertical rate (Hz, use in interlace mode)			95		
Detailed Timing 3 : Min Horizontal rate (KHz)			22		
Detailed Timing 3 : Max Horizontal rate (KHz)			105		
Detailed Timing 3 : Max Supported Pixel Clock (MHz)			170		
Detailed Timing 3 : GTF: set 00 if unused for GTF		00			
Detailed Timing 3 : GTF: set 0A if unused for GTF		0A			
Detailed Timing 3 : GTF: set 20 if unused for GTF		20			
Detailed Timing 4 : Descriptor Flag (2byte)			0		
Detailed Timing 4 : Flag (1byte)			0		
Detailed Timing 4 : Data Tag (0xFC=Monitor Name)		FC			
Extention Flag			0		

**EEDID Law Data for Reference**

HEX	0	1	2	3	4	5	6	7	8	9	A	B	C	D	E	F
0	00	FF	FF	FF	FF	FF	FF	00	24	4D	1F	25	01	01	01	01
1	01	0B	01	03	80	0C	1E	78	E8	83	94	9F	55	49	98	24
2	15	4E	52	2F	CF	00	31	59	45	59	61	59	81	80	A9	40
3	D1	C0	01	01	01	01	D0	39	00	D0	F3	60	12	90	68	80
4	13	10	E0	2C	11	00	00	1C	31	30	80	60	72	60	1C	90
5	68	C8	13	00	F0	2C	01	00	00	1C	00	00	00	FD	00	09
6	5F	16	69	11	00	0A	20	20	20	20	20	20	00	00	00	FC
7	00	49	42	4D	39	35	30	33	2D	54	32	32	31	0A	00	<b>3E</b>

**HEX '7F' :** Check Sum

**[Note]**

- (1) This LCD Monitor complies with "VESA ENHANCED EXTENDED DISPLAY IDENTIFICATION DATA STANDARD Release A, Revision 1" and supports "EEDID version 1.3".
- (2) Values for 32 bit Serial Number, Week of Manufacture, Year of Manufacture, and the Check Sum fields may be different by product.
- (3) Any field value is subject to change according to future function / configuration modifications or special requirements.

**5.1.3 DC - IN Connector**

DC-IN Connector

<b>Connector Name / Designation</b>	DC Power Input Connector
<b>Manufacturer</b>	JWT
<b>Type / Part Number</b>	C4201WR0-6P-NL

DC-IN Connector Pin Assignment

PIN #	SIGNAL NAME	Description
4, 5, 6	+ 16 V	+16.0V Power Supply for monitor assembly
1, 2, 3	RTN	+16.0V Return

### 5.1.4 Connector Location

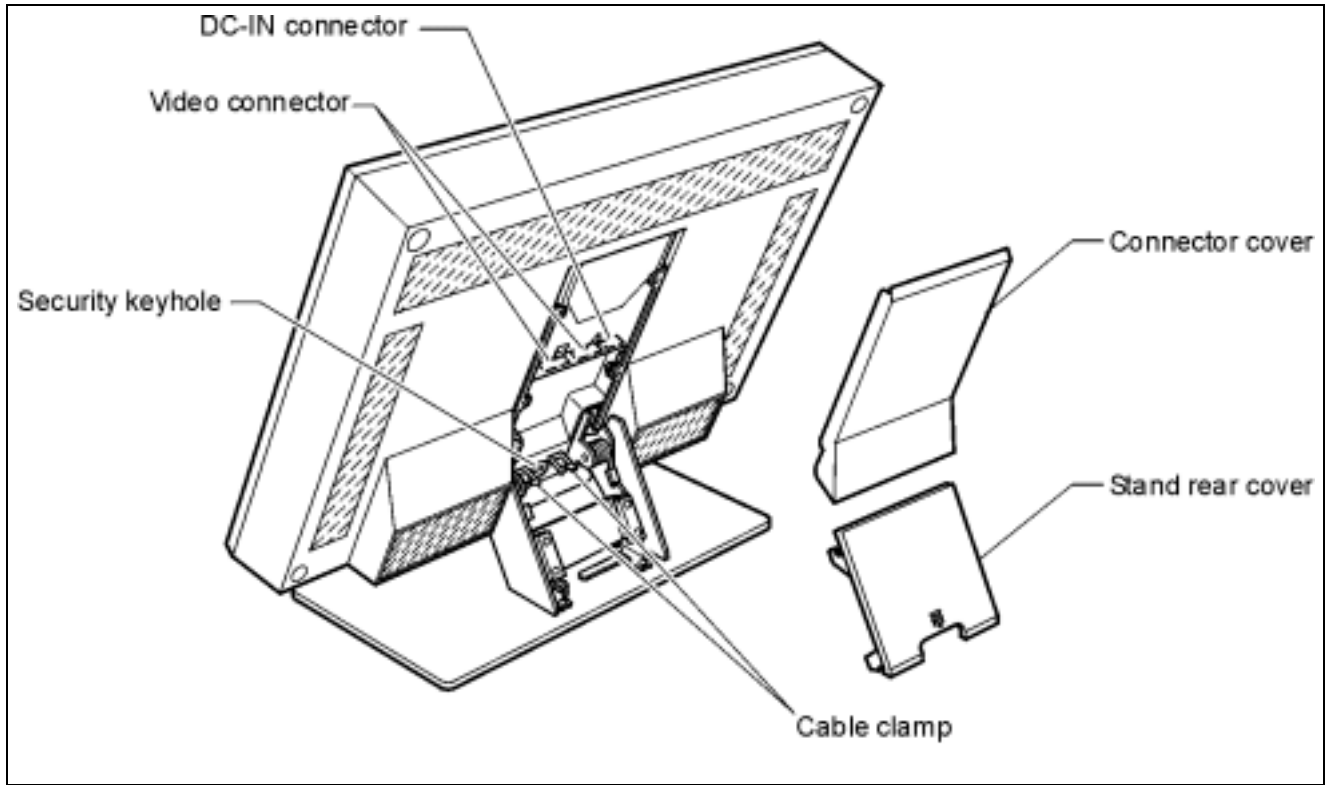

## 5.2 Electrical Interface Requirements

The monitor can accept only digital video data of TMDS in DVI interface. The monitor is driven with up to four DVI interfaces in two video cables. Each video cable accommodates two DVI signal sets.

The video data signal in each DVI interface shall meet requirements of the DVI specification.

The monitor support following four modes:

- 1) Single Screen mode
- 2) Two Vertical Stripe mode
- 3) Four Vertical Stripe mode
- 4) Four Tile mode

Single Screen mode

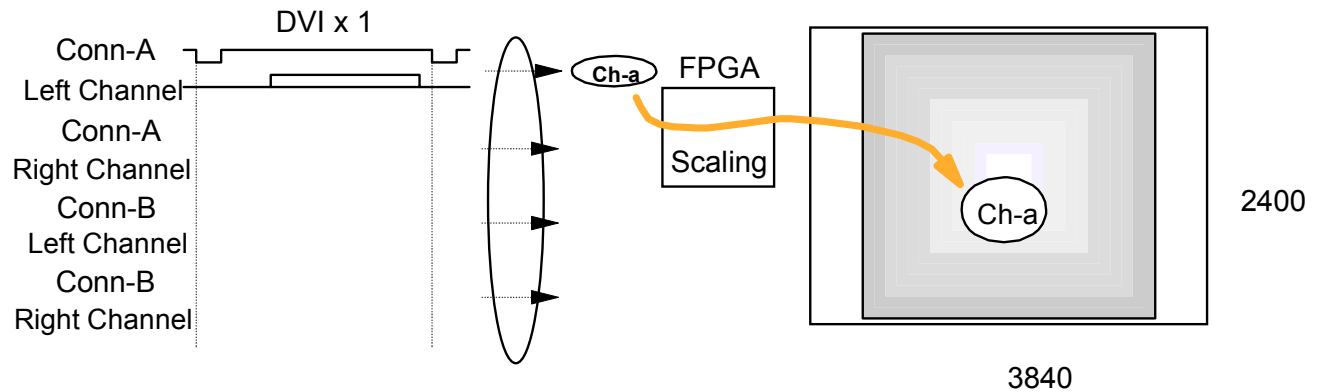

Two Vertical Stripe mode

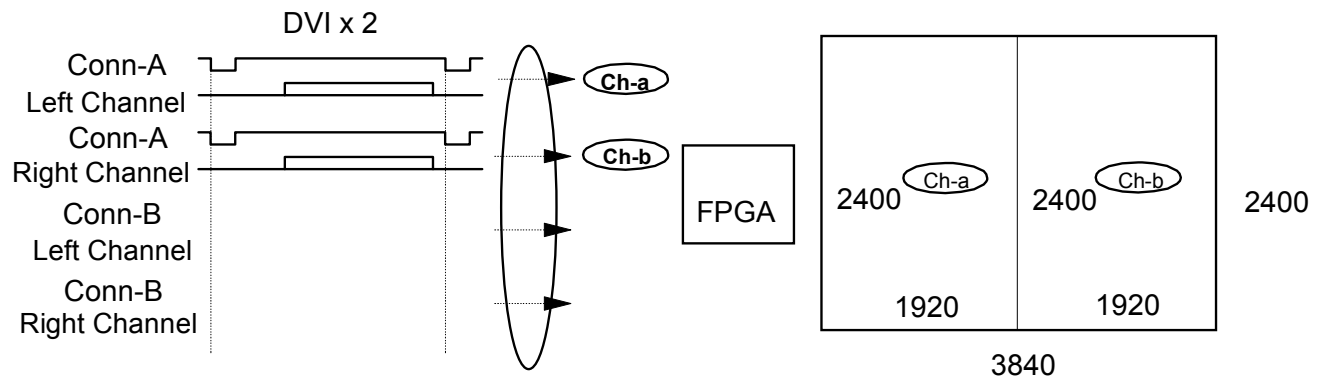

Four Vertical Stripe mode

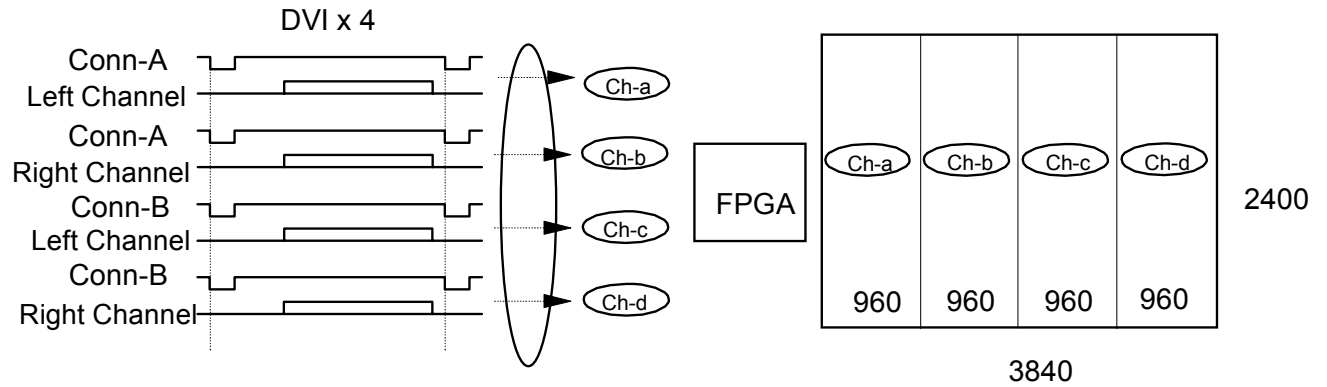

Four Tile mode

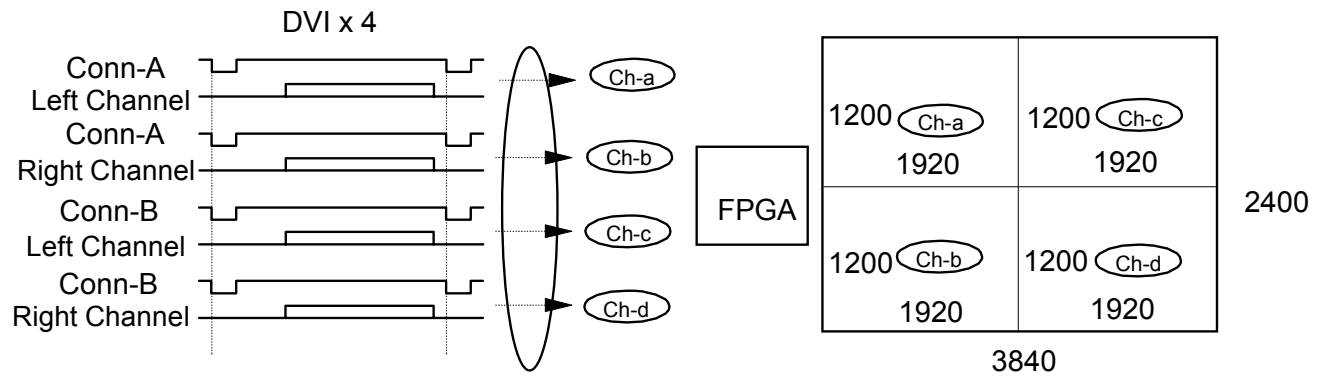

### 5.3 Interface Timings (each DVI input)

Reference Timing Chart (HSync: Positive, VSync: Positive Case)

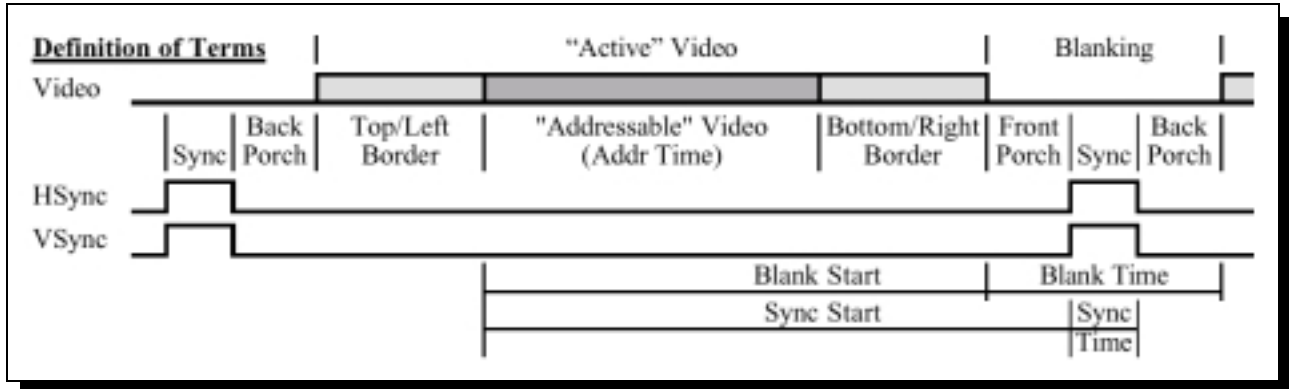

Reference Timing Chart (HSync: Negative, VSync: Negative Case)

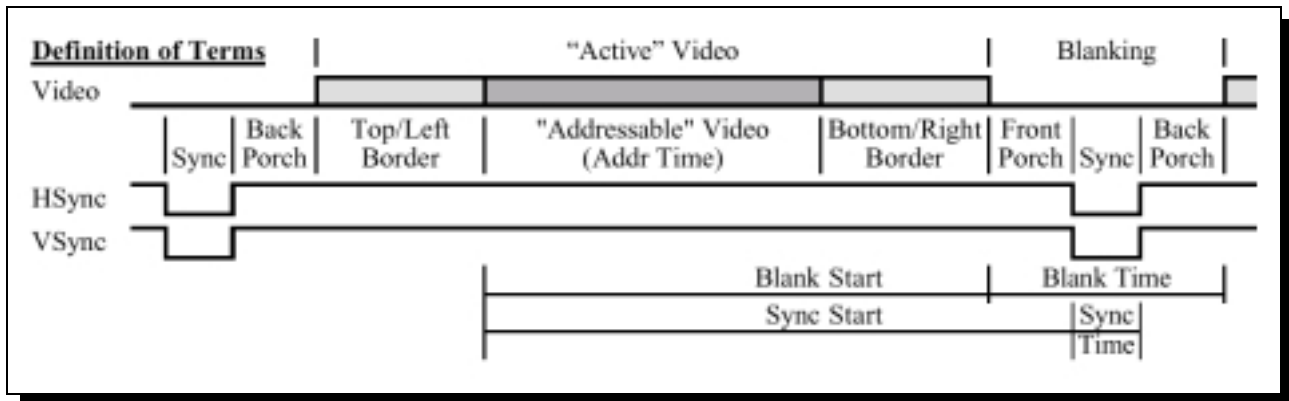

**(960x2400)x4 @ 41Hz, Four Vertical Stripe Mode (Each DVI Input Channel)**

**[Recommended Timing]**

Timing Name	=	(960x2400) x4 @ 41Hz		
Hor Pixels	=	960		
Ver Pixels	=	2400		
Hor Frequency	=	99.22 Khz	=	10.078 usec
Ver Frequency	=	40.93 Hz	=	24.43 msec
Pixel Clock	=	104.78 MHz	=	9.544 nsec
Scan Type	=	Non-Interlaced		
Hor Sync Polarity	=	Positive / Negative		
Ver Sync Polarity	=	Positive / Negative		
Disp. Enable Polarity	=	Positive		
Hor Total Time	=	10.078 usec	=	1056 Pixels
Hor Addr Time	=	9.162 usec	=	960 Pixels
Hor Blank Start	=	9.162 usec	=	960 Pixels
Hor Blank Time	=	0.916 usec	=	96 Pixels
Hor Sync Start	=	9.238 usec	=	968 Pixels
Hor Right Border	=	0.000 usec	=	0 Pixels
Hor Front Porch	=	0.076 usec	=	8 Pixels
Hor Sync Time	=	0.305 usec	=	32 Pixels
Hor Back Porch	=	0.534 usec	=	56 Pixels
Hor Left Border	=	0.000 usec	=	0 Pixels
Ver Total Time	=	24.43 msec	=	2424 lines
Ver Addr Time	=	24.19 msec	=	2400 lines
Ver Blank Start	=	24.19 msec	=	2400 lines
Ver Blank Time	=	0.241 msec	=	24 lines
Ver Sync Start	=	24.03 msec	=	2402 lines
Ver Bottom Border	=	0.000 msec	=	0 lines
Ver Front Porch	=	0.020 msec	=	2 line
Ver Sync Time	=	0.020 msec	=	2 lines
Ver Back Porch	=	0.201 msec	=	20 lines
Ver Top Border	=	0.000 msec	=	0 lines

**[Tolerance Condition]**

Pixel Clock ..... within +/- 0.5%

Ver Front Porch ..... min. 2 line  
 Ver Sync Time ..... min. 1 line  
 Ver Back Porch ..... min. 1 line  
 Ver Front Porch + Ver Sync Time < 3.3 msec  
 Ver Back Porch < 3.3 msec

Hor Front Porch ..... min 0 Pixel (Multiple Number of 8 is Recommended)  
 Hor Sync Time ..... min 2 Pixel (Multiple Number of 8 is Recommended)  
 Hor Back Porch ..... min 2 Pixel (Multiple Number of 8 is Recommended)

400 nsec < Hor Blank Time = Hor Front Porch + Hor Sync Time + Hor Back Porch < 3.3 msec

**[Inter Channel Tolerance]**

All 4 channels must be synchronized one another within the tolerance of 970 Pixels at maximum.

**(1920x1200) x4 @ 41Hz, Four Tile Mode (Each DVI Input Channel)**

**[Recommended Timing]**

Timing Name	=	(1920x1200) x4 @ 41Hz		
Hor Pixels	=	1920		
Ver Pixels	=	1200		
Hor Frequency	=	49.61 Khz	=	20.156 usec
Ver Frequency	=	40.93 Hz	=	24.43 msec
Pixel Clock	=	104.78 MHz	=	9.544 nsec
Scan Type	=	Non-Interlaced		
Hor Sync Polarity	=	Positive / Negative		
Ver Sync Polarity	=	Positive / Negative		
Disp. Enable Polarity	=	Positive		
Hor Total Time	=	20.156 usec	=	2112 Pixels
Hor Addr Time	=	18.324 usec	=	1920 Pixels
Hor Blank Start	=	18.324 usec	=	1920 Pixels
Hor Blank Time	=	1.832 usec	=	192 Pixels
Hor Sync Start	=	18.400 usec	=	1928 Pixels
Hor Right Border	=	0.000 usec	=	0 Pixels
Hor Front Porch	=	0.076 usec	=	8 Pixels
Hor Sync Time	=	0.305 usec	=	32 Pixels
Hor Back Porch	=	1.452 usec	=	152 Pixels
Hor Left Border	=	0.000 usec	=	0 Pixels
Ver Total Time	=	24.43 msec	=	1212 lines
Ver Addr Time	=	24.19 msec	=	1200 lines
Ver Blank Start	=	24.19 msec	=	1200 lines
Ver Blank Time	=	0.241 msec	=	12 lines
Ver Sync Start	=	24.21 msec	=	1201 lines
Ver Bottom Border	=	0.000 msec	=	0 lines
Ver Front Porch	=	0.020 msec	=	1 line
Ver Sync Time	=	0.040 msec	=	2 lines
Ver Back Porch	=	0.181 msec	=	9 lines
Ver Top Border	=	0.000 msec	=	0 lines

**[Tolerance Condition]**

Pixel Clock ..... within +/- 0.5%

Ver Front Porch ..... min. 1 line  
 Ver Sync Time ..... min. 1 line  
 Ver Back Porch ..... min. 1 line  
 Ver Front Porch + Ver Sync Time < 3.3 msec  
 Ver Back Porch < 3.3 msec

Hor Front Porch ..... min 0 Pixel (Multiple Number of 8 is Recommended)  
 Hor Sync Time ..... min 2 Pixel (Multiple Number of 8 is Recommended)  
 Hor Back Porch ..... min 2 Pixel (Multiple Number of 8 is Recommended)

400 nsec < Hor Blank Time = Hor Front Porch + Hor Sync Time + Hor Back Porch < 3.3 msec

**[Inter Channel Tolerance]**

All 4 channels must be synchronized one another within the tolerance of 970 Pixels at maximum.



**(1920x2400) x2 @ 20Hz, Two Vertical Stripe Mode (Each of Ch-a,b DVI Input)**

**[Recommended Timing]**

Timing Name	=	(1920x2400) x2 @ 20Hz	
Hor Pixels	=	1920	
Ver Pixels	=	2400	
Hor Frequency	=	48.924 Khz	= 20.440 usec
Ver Frequency	=	20.100 Hz	= 49.751 msec
Pixel Clock	=	100.000 MHz	= 10.000 nsec
Scan Type	=	Non-Interlaced	
Hor Sync Polarity	=	Positive / Negative	
Ver Sync Polarity	=	Positive / Negative	
Disp. Enable Polarity	=	Positive	
Hor Total Time	=	20.440 usec	= 2044 Pixels
Hor Addr Time	=	19.200 usec	= 1920 Pixels
Hor Blank Start	=	19.200 usec	= 1920 Pixels
Hor Blank Time	=	1.240 usec	= 124 Pixels
Hor Sync Start	=	19.280 usec	= 1928 Pixels
Hor Right Border	=	0.000 usec	= 0 Pixels
Hor Front Porch	=	0.080 usec	= 8 Pixels
Hor Sync Time	=	0.520 usec	= 52 Pixels
Hor Back Porch	=	0.640 usec	= 64 Pixels
Hor Left Border	=	0.000 usec	= 0 Pixels
Ver Total Time	=	49.751 msec	= 2434 lines
Ver Addr Time	=	49.056 msec	= 2400 lines
Ver Blank Start	=	49.056 msec	= 2400 lines
Ver Blank Time	=	0.695 msec	= 34 lines
Ver Sync Start	=	49.097 msec	= 2402 lines
Ver Bottom Border	=	0.000 msec	= 0 lines
Ver Front Porch	=	0.041 msec	= 2 lines
Ver Sync Time	=	0.041 msec	= 2 lines
Ver Back Porch	=	0.613 msec	= 30 lines
Ver Top Border	=	0.000 msec	= 0 lines

**[Tolerance Condition]**

Pixel Clock ..... within +/- 0.5%

Ver Front Porch ..... min. 1 line  
 Ver Sync Time ..... min. 1 line  
 Ver Back Porch ..... min. 1 line  
 Ver Front Porch + Ver Sync Time < 3.3 msec  
 Ver Back Porch < 3.3 msec

Hor Front Porch ..... min 0 Pixel (Multiple Number of 8 is Recommended)  
 Hor Sync Time ..... min 2 Pixel (Multiple Number of 8 is Recommended)  
 Hor Back Porch ..... min 2 Pixel (Multiple Number of 8 is Recommended)

400 nsec < Hor Blank Time = Hor Front Porch + Hor Sync Time + Hor Back Porch < 3.3 msec

**[Inter Channel Tolerance]**

Both 2 channels are recommended to synchronize each other within the tolerance of 970 Pixels at maximum.

## (1920x2400) x2 @ 24Hz, Two Vertical Stripe Mode (Each of Ch-a,b DVI Input)

### [Recommended Timing]

Timing Name	=	(1920x2400) x2 @ 24Hz		
Hor Pixels	=	1920		
Ver Pixels	=	2400		
Hor Frequency	=	58.708 Khz	=	17.033 usec
Ver Frequency	=	24.120 Hz	=	41.459 msec
Pixel Clock	=	120.000 MHz	=	8.333 nsec
Scan Type	=	Non-Interlaced		
Hor Sync Polarity	=	Positive / Negative		
Ver Sync Polarity	=	Positive / Negative		
Disp. Enable Polarity	=	Positive		
Hor Total Time	=	17.033 usec	=	2044 Pixels
Hor Addr Time	=	16.000 usec	=	1920 Pixels
Hor Blank Start	=	16.000 usec	=	1920 Pixels
Hor Blank Time	=	1.033 usec	=	124 Pixels
Hor Sync Start	=	16.067 usec	=	1928 Pixels
Hor Right Border	=	0.000 usec	=	0 Pixels
Hor Front Porch	=	0.067 usec	=	8 Pixels
Hor Sync Time	=	0.433 usec	=	52 Pixels
Hor Back Porch	=	0.533 usec	=	64 Pixels
Hor Left Border	=	0.000 usec	=	0 Pixels
Ver Total Time	=	41.459 msec	=	2434 lines
Ver Addr Time	=	40.880 msec	=	2400 lines
Ver Blank Start	=	40.880 msec	=	2400 lines
Ver Blank Time	=	0.579 msec	=	34 lines
Ver Sync Start	=	40.914 msec	=	2402 lines
Ver Bottom Border	=	0.000 msec	=	0 lines
Ver Front Porch	=	0.034 msec	=	2 lines
Ver Sync Time	=	0.034 msec	=	2 lines
Ver Back Porch	=	0.511 msec	=	30 lines
Ver Top Border	=	0.000 msec	=	0 lines

### [Tolerance Condition]

Pixel Clock ..... within +/- 0.5%

Ver Front Porch ..... min. 1 line

Ver Sync Time ..... min. 1 line

Ver Back Porch ..... min. 1 line

Ver Front Porch + Ver Sync Time < 3.3 msec

Ver Back Porch < 3.3 msec

Hor Front Porch ..... min 0 Pixel (Multiple Number of 8 is Recommended)

Hor Sync Time ..... min 2 Pixel (Multiple Number of 8 is Recommended)

Hor Back Porch ..... min 2 Pixel (Multiple Number of 8 is Recommended)

400 nsec < Hor Blank Time = Hor Front Porch + Hor Sync Time + Hor Back Porch < 3.3 msec

### [Inter Channel Tolerance]

Both 2 channels are recommended to synchronize each other within the tolerance of 970 Pixels at maximum.

**(1920x2400) x2 @ 25Hz, Two Vertical Stripe Mode (Each of Ch-a,b DVI Input)**

**[Recommended Timing]**

Timing Name	=	(1920x2400) x2 @ 25Hz		
Hor Pixels	=	1920		
Ver Pixels	=	2400		
Hor Frequency	=	61.155 Khz	=	16.352 usec
Ver Frequency	=	25.125 Hz	=	39.801 msec
Pixel Clock	=	125.000 MHz	=	8.000 nsec
Scan Type	=	Non-Interlaced		
Hor Sync Polarity	=	Positive / Negative		
Ver Sync Polarity	=	Positive / Negative		
Disp. Enable Polarity	=	Positive		
Hor Total Time	=	16.352 usec	=	2044 Pixels
Hor Addr Time	=	15.360 usec	=	1920 Pixels
Hor Blank Start	=	15.360 usec	=	1920 Pixels
Hor Blank Time	=	0.992 usec	=	124 Pixels
Hor Sync Start	=	15.424 usec	=	1928 Pixels
Hor Right Border	=	0.000 usec	=	0 Pixels
Hor Front Porch	=	0.064 usec	=	8 Pixels
Hor Sync Time	=	0.416 usec	=	52 Pixels
Hor Back Porch	=	0.512 usec	=	64 Pixels
Hor Left Border	=	0.000 usec	=	0 Pixels
Ver Total Time	=	39.801 msec	=	2434 lines
Ver Addr Time	=	39.245 msec	=	2400 lines
Ver Blank Start	=	39.245 msec	=	2400 lines
Ver Blank Time	=	0.556 msec	=	34 lines
Ver Sync Start	=	39.278 msec	=	2402 lines
Ver Bottom Border	=	0.000 msec	=	0 lines
Ver Front Porch	=	0.033 msec	=	2 lines
Ver Sync Time	=	0.033 msec	=	2 lines
Ver Back Porch	=	0.491 msec	=	30 lines
Ver Top Border	=	0.000 msec	=	0 lines

**[Tolerance Condition]**

Pixel Clock ..... within +/- 0.5%

Ver Front Porch ..... min. 1 line  
 Ver Sync Time ..... min. 1 line  
 Ver Back Porch ..... min. 1 line  
 Ver Front Porch + Ver Sync Time < 3.3 msec  
 Ver Back Porch < 3.3 msec

Hor Front Porch ..... min 0 Pixel (Multiple Number of 8 is Recommended)  
 Hor Sync Time ..... min 2 Pixel (Multiple Number of 8 is Recommended)  
 Hor Back Porch ..... min 2 Pixel (Multiple Number of 8 is Recommended)

400 nsec < Hor Blank Time = Hor Front Porch + Hor Sync Time + Hor Back Porch < 3.3 msec

**[Inter Channel Tolerance]**

Both 2 channels are recommended to synchronize each other within the tolerance of 970 Pixels at maximum.

### 3840x2400 @ 13Hz, Single Screen Mode (Ch-a DVI Input)

**[Recommended Timing]**

Timing Name	=	3840x2400 @ 13Hz		
Hor Pixels	=	3840		
Ver Pixels	=	2400		
Hor Frequency	=	31.5 Khz	=	31.75 usec
Ver Frequency	=	13.0 Hz	=	76.97 msec
Pixel Clock	=	129.000 MHz	=	7.75 nsec
Scan Type	=	Non-Interlaced		
Hor Sync Polarity	=	Positive / Negative		
Ver Sync Polarity	=	Positive / Negative		
Disp. Enable Polarity	=	Positive		
Hor Total Time	=	31.152 usec	=	4096 Pixels
Hor Addr Time	=	29.767 usec	=	3840 Pixels
Hor Blank Start	=	29.767 usec	=	3840 Pixels
Hor Blank Time	=	1.984 usec	=	256 Pixels
Hor Sync Start	=	29.829 usec	=	3848 Pixels
Hor Right Border	=	0.000 usec	=	0 Pixels
Hor Front Porch	=	0.062 usec	=	8 Pixels
Hor Sync Time	=	1.550 usec	=	200 Pixels
Hor Back Porch	=	0.372 usec	=	48 Pixels
Hor Left Border	=	0.000 usec	=	0 Pixels
Ver Total Time	=	76.967 msec	=	2424 lines
Ver Addr Time	=	76.205 msec	=	2400 lines
Ver Blank Start	=	76.205 msec	=	2400 lines
Ver Blank Time	=	0.762 msec	=	24 lines
Ver Sync Start	=	76.236 msec	=	2401 lines
Ver Bottom Border	=	0.000 msec	=	0 lines
Ver Front Porch	=	0.032 msec	=	1 lines
Ver Sync Time	=	0.064 msec	=	2 lines
Ver Back Porch	=	0.667 msec	=	21 lines
Ver Top Border	=	0.000 msec	=	0 lines

**[Tolerance Condition]**

Pixel Clock ..... within +/- 0.5%

Ver Front Porch ..... min. 1 line  
 Ver Sync Time ..... min. 1 line  
 Ver Back Porch ..... min. 1 line  
 Ver Front Porch + Ver Sync Time < 3.3 msec  
 Ver Back Porch < 3.3(recommended < 1ms)

Hor Front Porch ..... min 0 Pixel (Multiple Number of 8 is Recommended)  
 Hor Sync Time ..... min 2 Pixel (Multiple Number of 8 is Recommended)  
 Hor Back Porch ..... min 2 Pixel (Multiple Number of 8 is Recommended)

400 nsec < Hor Blank Time = Hor Front Porch + Hor Sync Time + Hor Back Porch < 3.3 msec

### 3840x2400 @ 13Hz (GTF Complied), Single Screen Mode (Ch-a DVI Input)

**[Recommended Timing]**

Timing Name	=	3840x2400 @ 13Hz (GTF Complied)		
Hor Pixels	=	3840		
Ver Pixels	=	2400		
Hor Frequency	=	30.73 Khz	=	32.54 usec
Ver Frequency	=	12.66 Hz	=	79.01 msec
Pixel Clock	=	148.000 MHz	=	6.76 nsec
Scan Type	=	Non-Interlaced		
Hor Sync Polarity	=	Negative / Positive		
Ver Sync Polarity	=	Positive / Negative		
Disp. Enable Polarity	=	Positive		
Hor Total Time	=	32.541 usec	=	4816 Pixels
Hor Addr Time	=	25.946 usec	=	3840 Pixels
Hor Blank Start	=	25.946 usec	=	3840 Pixels
Hor Blank Time	=	6.595 usec	=	976 Pixels
Hor Sync Start	=	26.649 usec	=	3944 Pixels
Hor Right Border	=	0.000 usec	=	0 Pixels
Hor Front Porch	=	0.703 usec	=	104 Pixels
Hor Sync Time	=	2.595 usec	=	384 Pixels
Hor Back Porch	=	3.297 usec	=	488 Pixels
Hor Left Border	=	0.000 usec	=	0 Pixels
Ver Total Time	=	79.008 msec	=	2428 lines
Ver Addr Time	=	78.097 msec	=	2400 lines
Ver Blank Start	=	78.097 msec	=	2400 lines
Ver Blank Time	=	0.911 msec	=	28 lines
Ver Sync Start	=	78.130 msec	=	2401 lines
Ver Bottom Border	=	0.000 msec	=	0 lines
Ver Front Porch	=	0.033 msec	=	1 lines
Ver Sync Time	=	0.098 msec	=	3 lines
Ver Back Porch	=	0.781 msec	=	24 lines
Ver Top Border	=	0.000 msec	=	0 lines

**[Tolerance Condition]**

Pixel Clock ..... within +/- 0.5%

Ver Front Porch ..... min. 1 line  
 Ver Sync Time ..... min. 1 line  
 Ver Back Porch ..... min. 1 line  
 Ver Front Porch + Ver Sync Time < 3.3 msec  
 Ver Back Porch < 3.3(recommended < 1ms)

Hor Front Porch ..... min 0 Pixel (Multiple Number of 8 is Recommended)  
 Hor Sync Time ..... min 2 Pixel (Multiple Number of 8 is Recommended)  
 Hor Back Porch ..... min 2 Pixel (Multiple Number of 8 is Recommended)

400 nsec < Hor Blank Time = Hor Front Porch + Hor Sync Time + Hor Back Porch < 3.3 msec

## 1920x1200 @ 41Hz (GTF Complied), Single Screen Mode (Ch-a DVI Input)

### [Recommended Timing]

Timing Name	=	1920x1200 @ 41Hz (GTF Complied)		
Hor Pixels	=	1920 Pixels		
Ver Pixels	=	1200 Lines		
Hor Frequency	=	50.303 Khz	=	19.88 usec / line
Ver Frequency	=	40.930 Hz	=	24.43 msec / frame
Pixel Clock	=	127.166 MHz	=	7.86 nsec
Scan Type	=	Non-Interlaced		
Hor Sync Polarity	=	Negative / Positive		
Ver Sync Polarity	=	Positive / Negative		
Disp. Enable Polarity	=	Positive		
Hor Total Time	=	19.880 usec	=	2528 Pixels
Hor Addr Time	=	15.098 usec	=	1920 Pixels
Hor Blank Start	=	15.098 usec	=	1920 Pixels
Hor Blank Time	=	4.781 usec	=	608 Pixels
Hor Sync Start	=	15.916 usec	=	2024 Pixels
Hor Right Border	=	0.000 usec	=	0 Pixels
Hor Front Porch	=	0.818 usec	=	104 Pixels
Hor Sync Time	=	1.573 usec	=	200 Pixels
Hor Back Porch	=	2.391 usec	=	304 Pixels
Hor Left Border	=	0.000 usec	=	0 Pixels
Ver Total Time	=	24.432 msec	=	1229 lines
Ver Addr Time	=	23.855 msec	=	1200 lines
Ver Blank Start	=	23.855 msec	=	1200 lines
Ver Blank Time	=	0.577 msec	=	29 lines
Ver Sync Start	=	23.875 msec	=	1201 lines
Ver Bottom Border	=	0.000 msec	=	0 lines
Ver Front Porch	=	0.020 msec	=	1 lines
Ver Sync Time	=	0.060 msec	=	3 lines
Ver Back Porch	=	0.497 msec	=	25 lines
Ver Top Border	=	0.000 msec	=	0 lines

### [Tolerance Condition]

Pixel Clock ..... within +/- 0.5%

Ver Front Porch ..... min. 1 line

Ver Sync Time ..... min. 1 line

Ver Back Porch ..... min. 1 line

Ver Front Porch + Ver Sync Time < 3.3 msec

Ver Back Porch < 3.3(recommended < 1ms)

Hor Front Porch ..... min 0 Pixel (Multiple Number of 8 is Recommended)

Hor Sync Time ..... min 2 Pixel (Multiple Number of 8 is Recommended)

Hor Back Porch ..... min 2 Pixel (Multiple Number of 8 is Recommended)

400 nsec < Hor Blank Time = Hor Front Porch + Hor Sync Time + Hor Back Porch < 3.3 msec

## 640x480 @ 60Hz, Single Screen Mode (Ch-a DVI Input)

**[Recommended Timing]** -- based on the VESA Monitor Timing Standard

Timing Name	=	640x480 @ 60Hz	
Hor Pixels	=	640 Pixels	
Ver Pixels	=	480 Lines	
Hor Frequency	=	31.469 Khz	= 31.8 usec / line
Ver Frequency	=	59.940 Hz	= 16.7 msec / frame
Pixel Clock	=	25.175 MHz	= 39.7 nsec
Scan Type	=	Non-Interlaced	
Hor Sync Polarity	=	Negative / Positive	
Ver Sync Polarity	=	Negative / Positive	
Disp. Enable Polarity	=	Positive	
Hor Total Time	=	31.778 usec	= 800 Pixels
Hor Addr Time	=	25.422 usec	= 640 Pixels
Hor Blank Start	=	25.740 usec	= 648 Pixels
Hor Blank Time	=	5.720 usec	= 144 Pixels
Hor Sync Start	=	26.058 usec	= 656 Pixels
Hor Right Border	=	0.318 usec	= 8 Pixels
Hor Front Porch	=	0.318 usec	= 8 Pixels
Hor Sync Time	=	3.813 usec	= 96 Pixels
Hor Back Porch	=	1.589 usec	= 40 Pixels
Hor Left Border	=	0.318 usec	= 8 Pixels
Ver Total Time	=	16.683 msec	= 525 lines
Ver Addr Time	=	15.253 msec	= 480 lines
Ver Blank Start	=	15.507 msec	= 488 lines
Ver Blank Time	=	0.922 msec	= 29 lines
Ver Sync Start	=	15.571 msec	= 490 lines
Ver Bottom Border	=	0.254 msec	= 8 lines
Ver Front Porch	=	0.064 msec	= 2 lines
Ver Sync Time	=	0.064 msec	= 2 lines
Ver Back Porch	=	0.794 msec	= 25 lines
Ver Top Border	=	0.254 msec	= 8 lines

### [Tolerance Condition]

Pixel Clock ..... within +/- 0.5%

Ver Front Porch ..... min. 1 line  
 Ver Sync Time ..... min. 1 line  
 Ver Back Porch ..... min. 1 line  
 Ver Front Porch + Ver Sync Time < 3.3 msec  
 Ver Back Porch < 3.3 msec

Hor Front Porch ..... min 0 Pixel (Multiple Number of 8 is Recommended)  
 Hor Sync Time ..... min 2 Pixel (Multiple Number of 8 is Recommended)  
 Hor Back Porch ..... min 2 Pixel (Multiple Number of 8 is Recommended)

400 nsec < Hor Blank Time = Hor Front Porch + Hor Sync Time + Hor Back Porch < 3.3 msec

## 640x480 @ 72Hz, Single Screen Mode (Ch-a DVI Input)

**[Recommended Timing]** -- based on the VESA Monitor Timing Standard

Timing Name	=	640x480 @ 72Hz	
Hor Pixels	=	640 Pixels	
Ver Pixels	=	480 Lines	
Hor Frequency	=	37.861 Khz	= 26.4 usec / line
Ver Frequency	=	72.809 Hz	= 13.7 msec / frame
Pixel Clock	=	31.500 MHz	= 31.7 nsec
Scan Type	=	Non-Interlaced	
Hor Sync Polarity	=	Negative / Positive	
Ver Sync Polarity	=	Negative / Positive	
Disp. Enable Polarity	=	Positive	
Hor Total Time	=	26.413 usec	= 832 Pixels
Hor Addr Time	=	20.317 usec	= 640 Pixels
Hor Blank Start	=	20.571 usec	= 648 Pixels
Hor Blank Time	=	5.587 usec	= 176 Pixels
Hor Sync Start	=	21.079 usec	= 664 Pixels
Hor Right Border	=	0.254 usec	= 8 Pixels
Hor Front Porch	=	0.508 usec	= 16 Pixels
Hor Sync Time	=	1.270 usec	= 40 Pixels
Hor Back Porch	=	3.810 usec	= 120 Pixels
Hor Left Border	=	0.254 usec	= 8 Pixels
Ver Total Time	=	13.735 msec	= 520 lines
Ver Addr Time	=	12.678 msec	= 480 lines
Ver Blank Start	=	12.889 msec	= 488 lines
Ver Blank Time	=	0.634 msec	= 24 lines
Ver Sync Start	=	12.916 msec	= 489 lines
Ver Bottom Border	=	0.211 msec	= 8 lines
Ver Front Porch	=	0.026 msec	= 1 lines
Ver Sync Time	=	0.079 msec	= 3 lines
Ver Back Porch	=	0.528 msec	= 20 lines
Ver Top Border	=	0.211 msec	= 8 lines

### [Tolerance Condition]

Pixel Clock ..... within +/- 0.5%

Ver Front Porch ..... min. 1 line  
 Ver Sync Time ..... min. 1 line  
 Ver Back Porch ..... min. 1 line  
 Ver Front Porch + Ver Sync Time < 3.3 msec  
 Ver Back Porch < 3.3 msec

Hor Front Porch ..... min 0 Pixel (Multiple Number of 8 is Recommended)  
 Hor Sync Time ..... min 2 Pixel (Multiple Number of 8 is Recommended)  
 Hor Back Porch ..... min 2 Pixel (Multiple Number of 8 is Recommended)

400 nsec < Hor Blank Time = Hor Front Porch + Hor Sync Time + Hor Back Porch < 3.3 msec



## 640x480 @ 75Hz, Single Screen Mode (Ch-a DVI Input)

**[Recommended Timing]** -- based on the VESA Monitor Timing Standard

Timing Name	=	640x480 @ 75Hz	
Hor Pixels	=	640 Pixels	
Ver Pixels	=	480 Lines	
Hor Frequency	=	37.500 Khz	= 26.7 usec / line
Ver Frequency	=	75.000 Hz	= 13.3 msec / frame
Pixel Clock	=	31.500 MHz	= 31.7 nsec (+/- 0.5%)
Scan Type	=	Non-Interlaced	
Hor Sync Polarity	=	Negative / Positive	
Ver Sync Polarity	=	Negative / Positive	
Disp. Enable Polarity	=	Positive	
Hor Total Time	=	26.667 usec	= 840 Pixels
Hor Addr Time	=	20.317 usec	= 640 Pixels
Hor Blank Start	=	20.317 usec	= 640 Pixels
Hor Blank Time	=	6.349 usec	= 200 Pixels
Hor Sync Start	=	20.825 usec	= 656 Pixels
Hor Right Border	=	0.000 usec	= 0 Pixels
Hor Front Porch	=	0.508 usec	= 16 Pixels
Hor Sync Time	=	2.032 usec	= 64 Pixels
Hor Back Porch	=	3.810 usec	= 120 Pixels
Hor Left Border	=	0.000 usec	= 0 Pixels
Ver Total Time	=	13.333 msec	= 500 lines
Ver Addr Time	=	12.800 msec	= 480 lines
Ver Blank Start	=	12.800 msec	= 480 lines
Ver Blank Time	=	0.533 msec	= 20 lines
Ver Sync Start	=	12.827 msec	= 481 lines
Ver Bottom Border	=	0.000 msec	= 0 lines
Ver Front Porch	=	0.027 msec	= 1 lines
Ver Sync Time	=	0.080 msec	= 3 lines
Ver Back Porch	=	0.427 msec	= 16 lines
Ver Top Border	=	0.000 msec	= 0 lines

### [Tolerance Condition]

Pixel Clock ..... within +/- 0.5%

Ver Front Porch ..... min. 1 line  
 Ver Sync Time ..... min. 1 line  
 Ver Back Porch ..... min. 1 line  
 Ver Front Porch + Ver Sync Time < 3.3 msec  
 Ver Back Porch < 3.3 msec

Hor Front Porch ..... min 0 Pixel (Multiple Number of 8 is Recommended)  
 Hor Sync Time ..... min 2 Pixel (Multiple Number of 8 is Recommended)  
 Hor Back Porch ..... min 2 Pixel (Multiple Number of 8 is Recommended)

400 nsec < Hor Blank Time = Hor Front Porch + Hor Sync Time + Hor Back Porch < 3.3 msec

## 640x480 @ 85Hz, Single Screen Mode (Ch-a DVI Input)

**[Recommended Timing]** -- based on the VESA Monitor Timing Standard

Timing Name	=	640x480 @ 85Hz	
Hor Pixels	=	640 Pixels	
Ver Pixels	=	480 Lines	
Hor Frequency	=	43.269 Khz	= 23.1 usec / line
Ver Frequency	=	85.008 Hz	= 11.8 msec / frame
Pixel Clock	=	36.000 MHz	= 27.8 nsec
Scan Type	=	Non-Interlaced	
Hor Sync Polarity	=	Negative / Positive	
Ver Sync Polarity	=	Negative / Positive	
Disp. Enable Polarity	=	Positive	
Hor Total Time	=	23.111 usec	= 832 Pixels
Hor Addr Time	=	17.778 usec	= 640 Pixels
Hor Blank Start	=	17.778 usec	= 640 Pixels
Hor Blank Time	=	5.333 usec	= 192 Pixels
Hor Sync Start	=	19.333 usec	= 696 Pixels
Hor Right Border	=	0.000 usec	= 0 Pixels
Hor Front Porch	=	1.556 usec	= 56 Pixels
Hor Sync Time	=	1.556 usec	= 56 Pixels
Hor Back Porch	=	2.222 usec	= 80 Pixels
Hor Left Border	=	0.000 usec	= 0 Pixels
Ver Total Time	=	11.764 msec	= 509 lines
Ver Addr Time	=	11.093 msec	= 480 lines
Ver Blank Start	=	11.093 msec	= 480 lines
Ver Blank Time	=	0.670 msec	= 29 lines
Ver Sync Start	=	11.116 msec	= 481 lines
Ver Bottom Border	=	0.000 msec	= 0 lines
Ver Front Porch	=	0.023 msec	= 1 lines
Ver Sync Time	=	0.069 msec	= 3 lines
Ver Back Porch	=	0.578 msec	= 25 lines
Ver Top Border	=	0.000 msec	= 0 lines

### [Tolerance Condition]

Pixel Clock ..... within +/- 0.5%

Ver Front Porch ..... min. 1 line  
 Ver Sync Time ..... min. 1 line  
 Ver Back Porch ..... min. 1 line  
 Ver Front Porch + Ver Sync Time < 3.3 msec  
 Ver Back Porch < 3.3 msec

Hor Front Porch ..... min 0 Pixel (Multiple Number of 8 is Recommended)  
 Hor Sync Time ..... min 2 Pixel (Multiple Number of 8 is Recommended)  
 Hor Back Porch ..... min 2 Pixel (Multiple Number of 8 is Recommended)

400 nsec < Hor Blank Time = Hor Front Porch + Hor Sync Time + Hor Back Porch < 3.3 msec

## 800x600 @ 56Hz, Single Screen Mode (Ch-a DVI Input)

**[Recommended Timing]** -- based on the VESA Monitor Timing Standard

Timing Name	=	800x600 @ 56Hz	
Hor Pixels	=	800 Pixels	
Ver Pixels	=	600 Lines	
Hor Frequency	=	35.156 Khz	= 28.4 usec / line
Ver Frequency	=	56.250 Hz	= 17.8 msec / frame
Pixel Clock	=	36.000 MHz	= 27.8 nsec
Scan Type	=	Non-Interlaced	
Hor Sync Polarity	=	Positive / Negative	
Ver Sync Polarity	=	Positive / Negative	
Disp. Enable Polarity	=	Positive	
Hor Total Time	=	28.444 usec	= 1024 Pixels
Hor Addr Time	=	22.222 usec	= 800 Pixels
Hor Blank Start	=	22.222 usec	= 800 Pixels
Hor Blank Time	=	6.222 usec	= 224 Pixels
Hor Sync Start	=	22.889 usec	= 824 Pixels
Hor Right Border	=	0.000 usec	= 0 Pixels
Hor Front Porch	=	0.667 usec	= 24 Pixels
Hor Sync Time	=	2.000 usec	= 72 Pixels
Hor Back Porch	=	3.556 usec	= 128 Pixels
Hor Left Border	=	0.000 usec	= 0 Pixels
Ver Total Time	=	17.778 msec	= 625 lines
Ver Addr Time	=	17.067 msec	= 600 lines
Ver Blank Start	=	17.067 msec	= 600 lines
Ver Blank Time	=	0.711 msec	= 25 lines
Ver Sync Start	=	17.095 msec	= 601 lines
Ver Bottom Border	=	0.000 msec	= 0 lines
Ver Front Porch	=	0.028 msec	= 1 lines
Ver Sync Time	=	0.057 msec	= 2 lines
Ver Back Porch	=	0.626 msec	= 22 lines
Ver Top Border	=	0.000 msec	= 0 lines

### [Tolerance Condition]

Pixel Clock ..... within +/- 0.5%

Ver Front Porch ..... min. 1 line  
 Ver Sync Time ..... min. 1 line  
 Ver Back Porch ..... min. 1 line  
 Ver Front Porch + Ver Sync Time < 3.3 msec  
 Ver Back Porch < 3.3 msec

Hor Front Porch ..... min 0 Pixel (Multiple Number of 8 is Recommended)  
 Hor Sync Time ..... min 2 Pixel (Multiple Number of 8 is Recommended)  
 Hor Back Porch ..... min 2 Pixel (Multiple Number of 8 is Recommended)

400 nsec < Hor Blank Time = Hor Front Porch + Hor Sync Time + Hor Back Porch < 3.3 msec

## 800x600 @ 60Hz, Single Screen Mode (Ch-a DVI Input)

**[Recommended Timing]** -- based on the VESA Monitor Timing Standard

Timing Name	=	800x600 @ 60Hz	
Hor Pixels	=	800 Pixels	
Ver Pixels	=	600 Lines	
Hor Frequency	=	37.879 Khz	= 26.4 usec / line
Ver Frequency	=	60.317 Hz	= 16.6 msec / frame
Pixel Clock	=	40.000 MHz	= 25.0 nsec
Scan Type	=	Non-Interlaced	
Hor Sync Polarity	=	Positive / Negative	
Ver Sync Polarity	=	Positive / Negative	
Disp. Enable Polarity	=	Positive	
Hor Total Time	=	26.400 usec	= 1056 Pixels
Hor Addr Time	=	20.000 usec	= 800 Pixels
Hor Blank Start	=	20.000 usec	= 800 Pixels
Hor Blank Time	=	6.400 usec	= 256 Pixels
Hor Sync Start	=	21.000 usec	= 840 Pixels
Hor Right Border	=	0.000 usec	= 0 Pixels
Hor Front Porch	=	1.000 usec	= 40 Pixels
Hor Sync Time	=	3.200 usec	= 128 Pixels
Hor Back Porch	=	2.200 usec	= 88 Pixels
Hor Left Border	=	0.000 usec	= 0 Pixels
Ver Total Time	=	16.579 msec	= 628 lines
Ver Addr Time	=	15.840 msec	= 600 lines
Ver Blank Start	=	15.840 msec	= 600 lines
Ver Blank Time	=	0.739 msec	= 28 lines
Ver Sync Start	=	15.866 msec	= 601 lines
Ver Bottom Border	=	0.000 msec	= 0 lines
Ver Front Porch	=	0.026 msec	= 1 lines
Ver Sync Time	=	0.106 msec	= 4 lines
Ver Back Porch	=	0.607 msec	= 23 lines
Ver Top Border	=	0.000 msec	= 0 lines

### [Tolerance Condition]

Pixel Clock ..... within +/- 0.5%

Ver Front Porch ..... min. 1 line  
 Ver Sync Time ..... min. 1 line  
 Ver Back Porch ..... min. 1 line  
 Ver Front Porch + Ver Sync Time < 3.3 msec  
 Ver Back Porch < 3.3 msec

Hor Front Porch ..... min 0 Pixel (Multiple Number of 8 is Recommended)  
 Hor Sync Time ..... min 2 Pixel (Multiple Number of 8 is Recommended)  
 Hor Back Porch ..... min 2 Pixel (Multiple Number of 8 is Recommended)

400 nsec < Hor Blank Time = Hor Front Porch + Hor Sync Time + Hor Back Porch < 3.3 msec

## 800x600 @ 72Hz, Single Screen Mode (Ch-a DVI Input)

**[Recommended Timing]** -- based on the VESA Monitor Timing Standard

Timing Name	=	800x600 @ 72Hz	
Hor Pixels	=	800 Pixels	
Ver Pixels	=	600 Lines	
Hor Frequency	=	48.077 Khz	= 20.8 usec / line
Ver Frequency	=	72.188 Hz	= 13.9 msec / frame
Pixel Clock	=	50.000 MHz	= 20.0 nsec
Scan Type	=	Non-Interlaced	
Hor Sync Polarity	=	Positive / Negative	
Ver Sync Polarity	=	Positive / Negative	
Disp. Enable Polarity	=	Positive	
Hor Total Time	=	20.800 usec	= 1040 Pixels
Hor Addr Time	=	16.000 usec	= 800 Pixels
Hor Blank Start	=	16.000 usec	= 800 Pixels
Hor Blank Time	=	4.800 usec	= 240 Pixels
Hor Sync Start	=	17.120 usec	= 856 Pixels
Hor Right Border	=	0.000 usec	= 0 Pixels
Hor Front Porch	=	1.120 usec	= 56 Pixels
Hor Sync Time	=	2.400 usec	= 120 Pixels
Hor Back Porch	=	1.280 usec	= 64 Pixels
Hor Left Border	=	0.000 usec	= 0 Pixels
Ver Total Time	=	13.853 msec	= 666 lines
Ver Addr Time	=	12.480 msec	= 600 lines
Ver Blank Start	=	12.480 msec	= 600 lines
Ver Blank Time	=	1.373 msec	= 66 lines
Ver Sync Start	=	13.250 msec	= 637 lines
Ver Bottom Border	=	0.000 msec	= 0 lines
Ver Front Porch	=	0.770 msec	= 37 lines
Ver Sync Time	=	0.125 msec	= 6 lines
Ver Back Porch	=	0.478 msec	= 23 lines
Ver Top Border	=	0.000 msec	= 0 lines

### [Tolerance Condition]

Pixel Clock ..... within +/- 0.5%

Ver Front Porch ..... min. 1 line

Ver Sync Time ..... min. 1 line

Ver Back Porch ..... min. 1 line

Ver Front Porch + Ver Sync Time < 3.3 msec

Ver Back Porch < 3.3 msec

Hor Front Porch ..... min 0 Pixel (Multiple Number of 8 is Recommended)

Hor Sync Time ..... min 2 Pixel (Multiple Number of 8 is Recommended)

Hor Back Porch ..... min 2 Pixel (Multiple Number of 8 is Recommended)

400 nsec < Hor Blank Time = Hor Front Porch + Hor Sync Time + Hor Back Porch < 3.3 msec

## 800x600 @ 75Hz, Single Screen Mode (Ch-a DVI Input)

**[Recommended Timing]** -- based on the VESA Monitor Timing Standard

Timing Name	=	800x600 @ 75Hz	
Hor Pixels	=	800 Pixels	
Ver Pixels	=	600 Lines	
Hor Frequency	=	46.875 Khz	= 21.3 usec / line
Ver Frequency	=	75.000 Hz	= 13.3 msec / frame
Pixel Clock	=	49.500 MHz	= 20.2 nsec
Scan Type	=	Non-Interlaced	
Hor Sync Polarity	=	Positive / Negative	
Ver Sync Polarity	=	Positive / Negative	
Disp. Enable Polarity	=	Positive	
Hor Total Time	=	21.333 usec	= 1056 Pixels
Hor Addr Time	=	16.162 usec	= 800 Pixels
Hor Blank Start	=	16.162 usec	= 800 Pixels
Hor Blank Time	=	5.172 usec	= 256 Pixels
Hor Sync Start	=	16.485 usec	= 816 Pixels
Hor Right Border	=	0.000 usec	= 0 Pixels
Hor Front Porch	=	0.323 usec	= 16 Pixels
Hor Sync Time	=	1.616 usec	= 80 Pixels
Hor Back Porch	=	3.232 usec	= 160 Pixels
Hor Left Border	=	0.000 usec	= 0 Pixels
Ver Total Time	=	13.333 msec	= 625 lines
Ver Addr Time	=	12.800 msec	= 600 lines
Ver Blank Start	=	12.800 msec	= 600 lines
Ver Blank Time	=	0.533 msec	= 25 lines
Ver Sync Start	=	12.821 msec	= 601 lines
Ver Bottom Border	=	0.000 msec	= 0 lines
Ver Front Porch	=	0.021 msec	= 1 lines
Ver Sync Time	=	0.064 msec	= 3 lines
Ver Back Porch	=	0.448 msec	= 21 lines
Ver Top Border	=	0.000 msec	= 0 lines

### [Tolerance Condition]

Pixel Clock ..... within +/- 0.5%

Ver Front Porch ..... min. 1 line  
 Ver Sync Time ..... min. 1 line  
 Ver Back Porch ..... min. 1 line  
 Ver Front Porch + Ver Sync Time < 3.3 msec  
 Ver Back Porch < 3.3 msec

Hor Front Porch ..... min 0 Pixel (Multiple Number of 8 is Recommended)  
 Hor Sync Time ..... min 2 Pixel (Multiple Number of 8 is Recommended)  
 Hor Back Porch ..... min 2 Pixel (Multiple Number of 8 is Recommended)

400 nsec < Hor Blank Time = Hor Front Porch + Hor Sync Time + Hor Back Porch < 3.3 msec

## 800x600 @ 85Hz, Single Screen Mode (Ch-a DVI Input)

**[Recommended Timing]** -- based on the VESA Monitor Timing Standard

Timing Name	=	800x600 @ 85Hz	
Hor Pixels	=	800 Pixels	
Ver Pixels	=	600 Lines	
Hor Frequency	=	53.674 Khz	= 18.6 usec / line
Ver Frequency	=	85.061 Hz	= 11.8 msec / frame
Pixel Clock	=	56.250 MHz	= 17.8 nsec
Scan Type	=	Non-Interlaced	
Hor Sync Polarity	=	Positive / Negative	
Ver Sync Polarity	=	Positive / Negative	
Disp. Enable Polarity	=	Positive	
Hor Total Time	=	18.631 usec	= 1048 Pixels
Hor Addr Time	=	14.222 usec	= 800 Pixels
Hor Blank Start	=	14.222 usec	= 800 Pixels
Hor Blank Time	=	4.409 usec	= 248 Pixels
Hor Sync Start	=	14.791 usec	= 832 Pixels
Hor Right Border	=	0.000 usec	= 0 Pixels
Hor Front Porch	=	0.569 usec	= 32 Pixels
Hor Sync Time	=	1.138 usec	= 64 Pixels
Hor Back Porch	=	2.702 usec	= 152 Pixels
Hor Left Border	=	0.000 usec	= 0 Pixels
Ver Total Time	=	11.756 msec	= 631 lines
Ver Addr Time	=	11.179 msec	= 600 lines
Ver Blank Start	=	11.179 msec	= 600 lines
Ver Blank Time	=	0.578 msec	= 31 lines
Ver Sync Start	=	11.197 msec	= 601 lines
Ver Bottom Border	=	0.000 msec	= 0 lines
Ver Front Porch	=	0.019 msec	= 1 lines
Ver Sync Time	=	0.056 msec	= 3 lines
Ver Back Porch	=	0.503 msec	= 27 lines
Ver Top Border	=	0.000 msec	= 0 lines

### [Tolerance Condition]

Pixel Clock ..... within +/- 0.5%

Ver Front Porch ..... min. 1 line  
 Ver Sync Time ..... min. 1 line  
 Ver Back Porch ..... min. 1 line  
 Ver Front Porch + Ver Sync Time < 3.3 msec  
 Ver Back Porch < 3.3 msec

Hor Front Porch ..... min 0 Pixel (Multiple Number of 8 is Recommended)  
 Hor Sync Time ..... min 2 Pixel (Multiple Number of 8 is Recommended)  
 Hor Back Porch ..... min 2 Pixel (Multiple Number of 8 is Recommended)

400 nsec < Hor Blank Time = Hor Front Porch + Hor Sync Time + Hor Back Porch < 3.3 msec

## 1024 x 768 @ 60Hz, Single Screen Mode (Ch-a DVI Input)

**[Recommended Timing]** -- based on the VESA Monitor Timing Standard

Timing Name	=	1024x768 @ 60Hz	
Hor Pixels	=	1024 Pixels	
Ver Pixels	=	768 Lines	
Hor Frequency	=	48.363 Khz	= 20.7 usec / line
Ver Frequency	=	60.004 Hz	= 16.7 msec / frame
Pixel Clock	=	65.000 MHz	= 15.4 nsec
Scan Type	=	Non-Interlaced	
Hor Sync Polarity	=	Negative / Positive	
Ver Sync Polarity	=	Negative / Positive	
Disp. Enable Polarity	=	Positive	
Hor Total Time	=	20.677 usec	= 1344 Pixels
Hor Addr Time	=	15.754 usec	= 1024 Pixels
Hor Blank Start	=	15.754 usec	= 1024 Pixels
Hor Blank Time	=	4.923 usec	= 320 Pixels
Hor Sync Start	=	16.123 usec	= 1048 Pixels
Hor Right Border	=	0.000 usec	= 0 Pixels
Hor Front Porch	=	0.369 usec	= 24 Pixels
Hor Sync Time	=	2.092 usec	= 136 Pixels
Hor Back Porch	=	2.462 usec	= 160 Pixels
Hor Left Border	=	0.000 usec	= 0 Pixels
Ver Total Time	=	16.666 msec	= 806 lines
Ver Addr Time	=	15.880 msec	= 768 lines
Ver Blank Start	=	15.880 msec	= 768 lines
Ver Blank Time	=	0.786 msec	= 38 lines
Ver Sync Start	=	15.942 msec	= 771 lines
Ver Bottom Border	=	0.000 msec	= 0 lines
Ver Front Porch	=	0.062 msec	= 3 lines
Ver Sync Time	=	0.124 msec	= 6 lines
Ver Back Porch	=	0.600 msec	= 29 lines
Ver Top Border	=	0.000 msec	= 0 lines

### [Tolerance Condition]

Pixel Clock ..... within +/- 0.5%

Ver Front Porch ..... min. 1 line  
 Ver Sync Time ..... min. 1 line  
 Ver Back Porch ..... min. 1 line  
 Ver Front Porch + Ver Sync Time < 3.3 msec  
 Ver Back Porch < 3.3 msec

Hor Front Porch ..... min 0 Pixel (Multiple Number of 8 is Recommended)  
 Hor Sync Time ..... min 2 Pixel (Multiple Number of 8 is Recommended)  
 Hor Back Porch ..... min 2 Pixel (Multiple Number of 8 is Recommended)

400 nsec < Hor Blank Time = Hor Front Porch + Hor Sync Time + Hor Back Porch < 3.3 msec



## 1024x768 @ 70Hz, Single Screen Mode (Ch-a DVI Input)

**[Recommended Timing]** -- based on the VESA Monitor Timing Standard

Timing Name	=	1024x768 @ 70Hz	
Hor Pixels	=	1024 Pixels	
Ver Pixels	=	768 Lines	
Hor Frequency	=	56.476 Khz	= 17.7 usec / line
Ver Frequency	=	70.069 Hz	= 14.3 msec / frame
Pixel Clock	=	75.000 MHz	= 13.3 nsec
Scan Type	=	Non-Interlaced	
Hor Sync Polarity	=	Negative / Positive	
Ver Sync Polarity	=	Negative / Positive	
Disp. Enable Polarity	=	Positive	
Hor Total Time	=	17.707 usec	= 1328 Pixels
Hor Addr Time	=	13.653 usec	= 1024 Pixels
Hor Blank Start	=	13.653 usec	= 1024 Pixels
Hor Blank Time	=	4.053 usec	= 304 Pixels
Hor Sync Start	=	13.973 usec	= 1048 Pixels
Hor Right Border	=	0.000 usec	= 0 Pixels
Hor Front Porch	=	0.320 usec	= 24 Pixels
Hor Sync Time	=	1.813 usec	= 136 Pixels
Hor Back Porch	=	1.920 usec	= 144 Pixels
Hor Left Border	=	0.000 usec	= 0 Pixels
Ver Total Time	=	14.272 msec	= 806 lines
Ver Addr Time	=	13.599 msec	= 768 lines
Ver Blank Start	=	13.599 msec	= 768 lines
Ver Blank Time	=	0.673 msec	= 38 lines
Ver Sync Start	=	13.652 msec	= 771 lines
Ver Bottom Border	=	0.000 msec	= 0 lines
Ver Front Porch	=	0.053 msec	= 3 lines
Ver Sync Time	=	0.106 msec	= 6 lines
Ver Back Porch	=	0.513 msec	= 29 lines
Ver Top Border	=	0.000 msec	= 0 lines

### [Tolerance Condition]

Pixel Clock ..... within +/- 0.5%

Ver Front Porch ..... min. 1 line  
 Ver Sync Time ..... min. 1 line  
 Ver Back Porch ..... min. 1 line  
 Ver Front Porch + Ver Sync Time < 3.3 msec  
 Ver Back Porch < 3.3 msec

Hor Front Porch ..... min 0 Pixel (Multiple Number of 8 is Recommended)  
 Hor Sync Time ..... min 2 Pixel (Multiple Number of 8 is Recommended)  
 Hor Back Porch ..... min 2 Pixel (Multiple Number of 8 is Recommended)

400 nsec < Hor Blank Time = Hor Front Porch + Hor Sync Time + Hor Back Porch < 3.3 msec

## 1024x768 @ 75Hz, Single Screen Mode (Ch-a DVI Input)

### [Recommended Timing] -- based on the VESA Monitor Timing Standard

Timing Name	=	1024x768 @ 75Hz	
Hor Pixels	=	1024 Pixels	
Ver Pixels	=	768 Lines	
Hor Frequency	=	60.023 Khz	= 16.7 usec / line
Ver Frequency	=	75.029 Hz	= 13.3 msec / frame
Pixel Clock	=	78.750 MHz	= 12.7 nsec
Scan Type	=	Non-Interlaced	
Hor Sync Polarity	=	Positive / Negative	
Ver Sync Polarity	=	Positive / Negative	
Disp. Enable Polarity	=	Positive	
Hor Total Time	=	16.660 usec	= 1312 Pixels
Hor Addr Time	=	13.003 usec	= 1024 Pixels
Hor Blank Start	=	13.003 usec	= 1024 Pixels
Hor Blank Time	=	3.657 usec	= 288 Pixels
Hor Sync Start	=	13.206 usec	= 1040 Pixels
Hor Right Border	=	0.000 usec	= 0 Pixels
Hor Front Porch	=	0.203 usec	= 16 Pixels
Hor Sync Time	=	1.219 usec	= 96 Pixels
Hor Back Porch	=	2.235 usec	= 176 Pixels
Hor Left Border	=	0.000 usec	= 0 Pixels
Ver Total Time	=	13.328 msec	= 800 lines
Ver Addr Time	=	12.795 msec	= 768 lines
Ver Blank Start	=	12.795 msec	= 768 lines
Ver Blank Time	=	0.533 msec	= 32 lines
Ver Sync Start	=	12.812 msec	= 769 lines
Ver Bottom Border	=	0.000 msec	= 0 lines
Ver Front Porch	=	0.017 msec	= 1 lines
Ver Sync Time	=	0.050 msec	= 3 lines
Ver Back Porch	=	0.466 msec	= 28 lines
Ver Top Border	=	0.000 msec	= 0 lines

### [Tolerance Condition]

Pixel Clock ..... within +/- 0.5%

Ver Front Porch ..... min. 1 line  
 Ver Sync Time ..... min. 1 line  
 Ver Back Porch ..... min. 1 line  
 Ver Front Porch + Ver Sync Time < 3.3 msec  
 Ver Back Porch < 3.3 msec

Hor Front Porch ..... min 0 Pixel (Multiple Number of 8 is Recommended)  
 Hor Sync Time ..... min 2 Pixel (Multiple Number of 8 is Recommended)  
 Hor Back Porch ..... min 2 Pixel (Multiple Number of 8 is Recommended)

400 nsec < Hor Blank Time = Hor Front Porch + Hor Sync Time + Hor Back Porch < 3.3 msec

## 1024x768 @ 85Hz, Single Screen Mode (Ch-a DVI Input)

**[Recommended Timing]** -- based on the VESA Monitor Timing Standard

Timing Name	=	1024x768 @ 85Hz	
Hor Pixels	=	1024 Pixels	
Ver Pixels	=	768 Lines	
Hor Frequency	=	68.677 Khz	= 14.6 usec / line
Ver Frequency	=	84.997 Hz	= 11.8 msec / frame
Pixel Clock	=	94.500 MHz	= 10.6 nsec
Scan Type	=	Non-Interlaced	
Hor Sync Polarity	=	Positive / Negative	
Ver Sync Polarity	=	Positive / Negative	
Disp. Enable Polarity	=	Positive	
Hor Total Time	=	14.561 usec	= 1376 Pixels
Hor Addr Time	=	10.836 usec	= 1024 Pixels
Hor Blank Start	=	10.836 usec	= 1024 Pixels
Hor Blank Time	=	3.725 usec	= 352 Pixels
Hor Sync Start	=	11.344 usec	= 1072 Pixels
Hor Right Border	=	0.000 usec	= 0 Pixels
Hor Front Porch	=	0.508 usec	= 48 Pixels
Hor Sync Time	=	1.016 usec	= 96 Pixels
Hor Back Porch	=	2.201 usec	= 208 Pixels
Hor Left Border	=	0.000 usec	= 0 Pixels
Ver Total Time	=	11.765 msec	= 808 lines
Ver Addr Time	=	11.183 msec	= 768 lines
Ver Blank Start	=	11.183 msec	= 768 lines
Ver Blank Time	=	0.582 msec	= 40 lines
Ver Sync Start	=	11.197 msec	= 769 lines
Ver Bottom Border	=	0.000 msec	= 0 lines
Ver Front Porch	=	0.015 msec	= 1 lines
Ver Sync Time	=	0.044 msec	= 3 lines
Ver Back Porch	=	0.524 msec	= 36 lines
Ver Top Border	=	0.000 msec	= 0 lines

### [Tolerance Condition]

Pixel Clock ..... within +/- 0.5%

Ver Front Porch ..... min. 1 line  
 Ver Sync Time ..... min. 1 line  
 Ver Back Porch ..... min. 1 line  
 Ver Front Porch + Ver Sync Time < 3.3 msec  
 Ver Back Porch < 3.3 msec

Hor Front Porch ..... min 0 Pixel (Multiple Number of 8 is Recommended)  
 Hor Sync Time ..... min 2 Pixel (Multiple Number of 8 is Recommended)  
 Hor Back Porch ..... min 2 Pixel (Multiple Number of 8 is Recommended)

400 nsec < Hor Blank Time = Hor Front Porch + Hor Sync Time + Hor Back Porch < 3.3 msec

## 1280x1024 @ 60Hz, Single Screen Mode (Ch-a DVI Input)

**[Recommended Timing]** -- based on the VESA Monitor Timing Standard

Timing Name	=	1280x1024 @ 60Hz	
Hor Pixels	=	1280 Pixels	
Ver Pixels	=	1024 Lines	
Hor Frequency	=	63.981 Khz	= 15.6 usec / line
Ver Frequency	=	60.020 Hz	= 16.7 msec / frame
Pixel Clock	=	108.000 MHz	= 9.3 nsec
Scan Type	=	Non-Interlaced	
Hor Sync Polarity	=	Positive / Negative	
Ver Sync Polarity	=	Positive / Negative	
Disp. Enable Polarity	=	Positive	
Hor Total Time	=	15.630 usec	= 1688 Pixels
Hor Addr Time	=	11.852 usec	= 1280 Pixels
Hor Blank Start	=	11.852 usec	= 1280 Pixels
Hor Blank Time	=	3.778 usec	= 408 Pixels
Hor Sync Start	=	12.296 usec	= 1328 Pixels
Hor Right Border	=	0.000 usec	= 0 Pixels
Hor Front Porch	=	0.444 usec	= 48 Pixels
Hor Sync Time	=	1.037 usec	= 112 Pixels
Hor Back Porch	=	2.296 usec	= 248 Pixels
Hor Left Border	=	0.000 usec	= 0 Pixels
Ver Total Time	=	16.661 msec	= 1066 lines
Ver Addr Time	=	16.005 msec	= 1024 lines
Ver Blank Start	=	16.005 msec	= 1024 lines
Ver Blank Time	=	0.656 msec	= 42 lines
Ver Sync Start	=	16.020 msec	= 1025 lines
Ver Bottom Border	=	0.000 msec	= 0 lines
Ver Front Porch	=	0.016 msec	= 1 lines
Ver Sync Time	=	0.047 msec	= 3 lines
Ver Back Porch	=	0.594 msec	= 38 lines
Ver Top Border	=	0.000 msec	= 0 lines

### [Tolerance Condition]

Pixel Clock ..... within +/- 0.5%

Ver Front Porch ..... min. 1 line

Ver Sync Time ..... min. 1 line

Ver Back Porch ..... min. 1 line

Ver Front Porch + Ver Sync Time < 3.3 msec

Ver Back Porch < 3.3 msec

Hor Front Porch ..... min 0 Pixel (Multiple Number of 8 is Recommended)

Hor Sync Time ..... min 2 Pixel (Multiple Number of 8 is Recommended)

Hor Back Porch ..... min 2 Pixel (Multiple Number of 8 is Recommended)

400 nsec < Hor Blank Time = Hor Front Porch + Hor Sync Time + Hor Back Porch < 3.3 msec

## 1280x1024 @ 75Hz, Single Screen Mode (Ch-a DVI Input)

**[Recommended Timing]** -- based on the VESA Monitor Timing Standard

Timing Name	=	1280x1024 @ 75Hz	
Hor Pixels	=	1280 Pixels	
Ver Pixels	=	1024 Lines	
Hor Frequency	=	79.976 Khz	= 12.5 usec / line
Ver Frequency	=	75.025 Hz	= 13.3 msec / frame
Pixel Clock	=	135.000 MHz	= 7.4 nsec
Scan Type	=	Non-Interlaced	
Hor Sync Polarity	=	Positive / Negative	
Ver Sync Polarity	=	Positive / Negative	
Disp. Enable Polarity	=	Positive	
Hor Total Time	=	12.504 usec	= 1688 Pixels
Hor Addr Time	=	9.481 usec	= 1280 Pixels
Hor Blank Start	=	9.481 usec	= 1280 Pixels
Hor Blank Time	=	3.022 usec	= 408 Pixels
Hor Sync Start	=	9.600 usec	= 1296 Pixels
Hor Right Border	=	0.000 usec	= 0 Pixels
Hor Front Porch	=	0.119 usec	= 16 Pixels
Hor Sync Time	=	1.067 usec	= 144 Pixels
Hor Back Porch	=	1.837 usec	= 248 Pixels
Hor Left Border	=	0.000 usec	= 0 Pixels
Ver Total Time	=	13.329 msec	= 1066 lines
Ver Addr Time	=	12.804 msec	= 1024 lines
Ver Blank Start	=	12.804 msec	= 1024 lines
Ver Blank Time	=	0.525 msec	= 42 lines
Ver Sync Start	=	12.816 msec	= 1025 lines
Ver Bottom Border	=	0.000 msec	= 0 lines
Ver Front Porch	=	0.013 msec	= 1 lines
Ver Sync Time	=	0.038 msec	= 3 lines
Ver Back Porch	=	0.475 msec	= 38 lines
Ver Top Border	=	0.000 msec	= 0 lines

### [Tolerance Condition]

Pixel Clock ..... within +/- 0.5%

Ver Front Porch ..... min. 1 line  
 Ver Sync Time ..... min. 1 line  
 Ver Back Porch ..... min. 1 line  
 Ver Front Porch + Ver Sync Time < 3.3 msec  
 Ver Back Porch < 3.3 msec

Hor Front Porch ..... min 0 Pixel (Multiple Number of 8 is Recommended)  
 Hor Sync Time ..... min 2 Pixel (Multiple Number of 8 is Recommended)  
 Hor Back Porch ..... min 2 Pixel (Multiple Number of 8 is Recommended)

400 nsec < Hor Blank Time = Hor Front Porch + Hor Sync Time + Hor Back Porch < 3.3 msec

## 1600x1200 @ 60Hz, Single Screen Mode (Ch-a DVI Input)

**[Recommended Timing]** -- based on the VESA Monitor Timing Standard

Timing Name	=	1600x1200 @ 60Hz	
Hor Pixels	=	1600 Pixels	
Ver Pixels	=	1200 Lines	
Hor Frequency	=	75.000 Khz	= 13.3 usec / line
Ver Frequency	=	60.000 Hz	= 16.7 msec / frame
Pixel Clock	=	162.000 MHz	= 6.2 nsec
Scan Type	=	Non-Interlaced	
Hor Sync Polarity	=	Positive / Negative	
Ver Sync Polarity	=	Positive / Negative	
Disp. Enable Polarity	=	Positive	
Hor Total Time	=	13.333 usec	= 2160 Pixels
Hor Addr Time	=	9.877 usec	= 1600 Pixels
Hor Blank Start	=	9.877 usec	= 1600 Pixels
Hor Blank Time	=	3.457 usec	= 560 Pixels
Hor Sync Start	=	10.272 usec	= 1664 Pixels
Hor Right Border	=	0.000 usec	= 0 Pixels
Hor Front Porch	=	0.395 usec	= 64 Pixels
Hor Sync Time	=	1.185 usec	= 192 Pixels
Hor Back Porch	=	1.877 usec	= 304 Pixels
Hor Left Border	=	0.000 usec	= 0 Pixels
Ver Total Time	=	16.667 msec	= 1250 lines
Ver Addr Time	=	16.000 msec	= 1200 lines
Ver Blank Start	=	16.000 msec	= 1200 lines
Ver Blank Time	=	0.667 msec	= 50 lines
Ver Sync Start	=	16.013 msec	= 1201 lines
Ver Bottom Border	=	0.000 msec	= 0 lines
Ver Front Porch	=	0.013 msec	= 1 lines
Ver Sync Time	=	0.040 msec	= 3 lines
Ver Back Porch	=	0.613 msec	= 46 lines
Ver Top Border	=	0.000 msec	= 0 lines

### [Tolerance Condition]

Pixel Clock ..... within +/- 0.5%

Ver Front Porch ..... min. 1 line  
 Ver Sync Time ..... min. 1 line  
 Ver Back Porch ..... min. 1 line  
 Ver Front Porch + Ver Sync Time < 3.3 msec  
 Ver Back Porch < 3.3 msec

Hor Front Porch ..... min 0 Pixel (Multiple Number of 8 is Recommended)  
 Hor Sync Time ..... min 2 Pixel (Multiple Number of 8 is Recommended)  
 Hor Back Porch ..... min 2 Pixel (Multiple Number of 8 is Recommended)

$1.45 \text{ usec}^*1 < \text{Hor Blank Time} = \text{Hor Front Porch} + \text{Hor Sync Time} + \text{Hor Back Porch} < 3.3 \text{ msec}$

\*1 : Minimum Hor Blank Time is calculated based on the following formula  
 $400 \text{ ns} + ((( [\text{Pixel Clock}] \text{ MHz} - 160 \text{ MHz} ) / 80 \text{ MHz} ) \times 3 ) \times [\text{H Addr Time}]$

## 960x1200 (Matrox DOS/VGA) @ 56Hz, Single Screen Mode (Ch-a DVI Input)

### [Recommended Timing & Tolerance Condition]

Timing Name	=	960x1200 (Matrox DOS/VGA) @ 56Hz	
Hor Pixels	=	960	
Ver Pixels	=	1200	
Hor Frequency	=	67.218 Khz	= 14.88 usec
Ver Frequency	=	55.74 Hz	= 17.94 msec
Pixel Clock	=	70.98 MHz	= 14.088 nsec
			(min. 60 MHz / Max. 100 MHz)
Scan Type	=	Non-Interlaced	
Hor Sync Polarity	=	Positive / Negative	
Ver Sync Polarity	=	Positive / Negative	
Disp. Enable Polarity	=	Positive	
Hor Total Time	=	14.877 usec	= 1056 Pixels
			(min. 1036 pixels / Max. 1540 pixels)
Hor Addr Time	=	13.525 usec	= 960 Pixels
			(only this pixel value is allowed)
Hor Blank Start	=	13.525 usec	= 960 Pixels
			(only this pixel value is allowed)
Hor Blank Time	=	1.352 usec	= 96 Pixels
			(min. 76 pixels / Max. 580 pixels)
Hor Sync Start	=	1.364 usec	= 968 Pixels (min. 960 Pixels)
Hor Right Border	=	0.000 usec	= 0 Pixels
			(only this pixel value is allowed)
Hor Front Porch	=	0.113 usec	= 8 Pixels (min. 0 Pixel)
Hor Sync Time	=	0.451 usec	= 32 Pixels (min. 1 Pixel)
Hor Back Porch	=	0.789 usec	= 56 Pixels (min. 1 Pixel)
Hor Left Border	=	0.000 usec	= 0 Pixels
			(only this pixel value is allowed)
Ver Total Time	=	17.94 msec	= 1206 lines
			(min. 1205 lines / Max. 1238 lines)
Ver Addr Time	=	17.85 msec	= 1200 lines
			(only this line value is allowed)
Ver Blank Start	=	17.85 msec	= 1200 lines
			(only this line value is allowed)
Ver Blank Time	=	0.089 msec	= 6 lines
			(min. 5 lines/Max. 38 lines)
Ver Sync Start	=	17.85 msec	= 1200 lines (min. 1200 lines)
Ver Bottom Border	=	0.000 msec	= 0 line
			(only this line value is allowed)
Ver Front Porch	=	0.000 msec	= 0 line (min. 0 line)
Ver Sync Time	=	0.030 msec	= 2 lines (min. 1 line)
Ver Back Porch	=	0.60 msec	= 4 lines (min. 4 lines)
Ver Top Border	=	0.000 msec	= 0 lines
			(only this line value is allowed)

## 5.4 Input Powers

### 5.4.1 Power Specifications

DC input power specifications are as follows;  
 Single AC/DC adapter is required to supply DC power for the monitor. The DC output of each AC/DC adapter shall satisfy the following characteristics.

#### Power Requirements

SYMBOL	PARAMETER	Min	Typ	Max	UNITS	CONDITION
Vin	+16V DC for monitor assembly	15.5	16	16.8	V	
Iin	DCin Current			10.5	A	Vin=16V
Pin	DCin Power			160	W	Vin=16V
Vin rp	Allowable Ripple Voltage			100	mVp-p	

**(Note)** AC/DC Adapter used for the monitor should be 160W AC Adapter(P/N : 07N2277).



## 6.0 Front of Screen Performance

### 6.1 General

The monitor meet the specifications described in this section. The requirements are satisfied in any specified condition unless otherwise noted.

### 6.2 White Luminance

1. All the measurements shall be made with the backlight on and after 60 minutes of the application of power and input signals.
2. All the pixels in the unselected state(white).
3. All the measurements shall be made in a dark room(at 25 +/- 3 deg.C) with a photometer that is perpendicular to the screen.

#### 6.2.1 White Luminance Specifications

The white luminance of the display is specified as follows:

##### White Luminance

Min	Typ	Max	unit
200	235	-	cd/m <sup>2</sup>

##### Brightness Control Range

Min	Typ	Max	unit
20 - 100	10 - 100	-	%

Maximum White Luminance = 100%

## 6.3 Color

### 6.3.1 Chromaticity

The color point of each color element which is defined as the C.I.E. 1931 x,y coordinate readings on each primary color through the center of the screen is given in the table shown below.

Chromaticity

Color	x	y
Red	0.638 +/- 0.040	0.340 +/- 0.030
Green	0.292 +/- 0.030	0.611 +/- 0.030
Blue	0.146 +/- 0.030	0.085 +/- 0.040

**Note:** Initial Value

### 6.3.2 White Balance

White balance defined as the C.I.E. 1931 x,y coordinate readings on maximum brightness through the center of the screen is given in the table shown below.

White Balance

	Value
x	0.313 +/- 0.030
y	0.329 +/- 0.030

**Note:** Initial Value

## 6.4 Finger Pressure Distortion

The pressure distortion is allowed only if any affects disappear in 10 seconds after the removal of pressure at the center of the screen by IEC test finger with a 100g load for 5 seconds at L255 state. It will be evaluated in visual inspection performed at a 500mm viewing distance and the following viewing cone in 500 lux ambient illumination.

**Vertical** +/-40 degree

**Horizontal** +/-40 degree

## 6.5 Gray Scale

The monitor has a gray scale consisting of 256 addressable levels. The code points for these levels are numbered  $i=0,1,\dots,255$ .  $i=0$  is the least luminous level, and  $i=255$  is the most luminous level. The luminance is exponential to the gray level( $i$ ). The value of power(exponent) is approximately 2.2 for this model, as shown below.

Luminance vs Each Gray Level

<b>i (gray level)</b>	<b>LP(i) Typical (%)</b>
<b>L0</b>	0.3
<b>L31</b>	1.0
<b>L63</b>	5.0
<b>L95</b>	12.0
<b>L127</b>	22.0
<b>L159</b>	35.0
<b>L191</b>	53.0
<b>L223</b>	75.0
<b>L255</b>	100.0

## 6.6 Optical Response Time

### 6.6.1 Definition

1. Optical response time "ON" is defined as the amount of the time from 10% luminance level to 90% luminance level for a group of pixels in changing the gray scale level from L0 to L255. And optical response time "OFF" is defined as the amount of the time from 90% luminance level to 10% luminance level for a group of pixels in changing the gray scale level from L255 to L0.
2. Optical response time shall be measured over an area on the screen that is larger than a single pixel.
3. Both the "ON" and "OFF" response time shall be measured between all Black and all White.
4. Both the ON and OFF response time shall be measured from the falling edge of the +DSPTMG signal for line 1200. Line 1200 is the center scan line of the test patterns.
5. All the measurements shall be made with the photometer positioned perpendicular to the screen.

### 6.6.2 Characteristics

Optical response time characteristics are as follows;

Optical Response Time

	<b>environment</b>	<b>value(typ.)</b>	<b>unit</b>
<b>Typical on or off response time</b>	25 deg.C	25	msec
<b>Maximum on or off response time</b>	25 deg.C	50	msec
<b>Maximum on or off response time</b>	0 deg.C	100	msec

## 7.0 EMC Requirements

The monitor shall satisfy the following electromagnetic compatibility performance, and meet the requirement of N-B 2-0001-038 European Community Electromagnetic Compatibility Directive for CE marking.

- EN55022/24, EN61000-3, for CE Marking

### 7.1 EMI Performance

The monitor shall meet the following EMI requirements;

- United States Federal Communications Commission (FCC) Rules and Regulation, Part 15 Subpart J for computing device "Class A Limits".
- VCCI Limit Class-A.
- CISPR22 Class A.

### 7.2 Very/Extra Low Frequency Magnetic Field

The monitor shall meet as follows;

Frequency	Maximum Value	unit(RMS)
5Hz - 2kHz	200	nT
2kHz - 400kHz	25	nT

### 7.3 Very/Extra Low Frequency Electric Field

The monitor shall meet as follows;

Frequency	Maximum Value	unit(RMS)
5Hz - 2kHz	10	V/m
2kHz - 400kHz	1	V/m

## 8.0 Environment

The monitor shall meet the provision of this specification during operating condition or after storage or shipment condition specified below. Operation at 10% beyond the specified range will not cause physical damage to the unit.

### 8.1 Temperature and Humidity

#### 8.1.1 Operating Conditions

The monitor shall operate error free under the following conditions;

**Temperature** 0 degree C to 35 degree C (Class B extended)  
**Relative Humidity** 8 % to 80%  
**Wet Bulb Temperature** 23.0 degree C (and No condensation)

#### 8.1.2 Shipping Conditions

The monitor shall operate error free after the following conditions;

**Temperature** -20 degree C to 60 degree C  
**Relative Humidity** 5 % to 95%  
**Wet Bulb Temperature** 39.0 degree C (and No condensation)

## 8.2 Atmospheric Pressure

The monitor shall be capable of being operated without affecting its operations over the pressure range specified as below;

#### Atmospheric Pressure

	<b>Pressure</b>	<b>note</b>
Maximum Pressure	104.0 kPa	(Sea level)
Minimum Pressure	67.4 kPa	(3,048 m)

## 9.0 Industry Standards (IEEE, ISO, IEC, and so on)

The monitor with AC/DC Adapter(s) satisfies the requirements for compliance with

UL 1950, 3rd Ed.

CAN / CSA C22.2 No.950-95

IEC 60950 2nd Ed., 1991 + Amd. 1, 1992 + Amd. 2, 1993 + Amd. 3, 1995 + Amd. 4, 1996.

EN 60950 : 1992 + A1 : 1993 + A2 : 1993 + A3 : 1995 + A4 : 1997 + A11

TUV - GS

Energy Star

## 10.0 Backlight Life

Backlight Life Time	30,000(Typ.) Hours	condition 25 degree C
---------------------	--------------------	-----------------------

\*\*\*\*\* End Of Page \*\*\*\*\*