

Advance Information

Antenna Switch Controller

The MDC5100 is designed to control GaAs RF switches which require positive and negative going control voltages to select the switch path. All input control signals are 3 V CMOS–logic compatible to allow for direct interface to a microcontroller. The device also has an accessory detect pin for use in applications where there is a portable handset to mobile adapter. The device is designed to interface directly with Double Pull–Double Throw (DPDT) switches such as the M/A–Com SW 363.

This device in combination with a GaAs RF switch can be used to achieve duplex isolation in many Time Division Duplex Radios like DECT or in Frequency Division Duplex Radios employing time division multiple access with staggered Transit/Receive time slots such as GSM. It can also be used to control an RF switch in dual band radio applications. The device is housed in a miniature Micro–8 for minimum space utilization.

Features

- Micro–miniature Low Profile Micro 8 Package
- 3 V CMOS Logic Control Inputs
- Ultra–low Quiescent Current of 400 μ A Typical
- Wide Operating Temperature Range of –40 to 85°C

Applications

- GSM and PCS Portable Phones
- Mobile to Portable Accessories
- Wireless LAN Modems
- Specialized TDD and TDMA Radios
- Dual Band Phones

MDC5100

**ANTENNA
SWITCH
CONTROLLER**



**PLASTIC PACKAGE
CASE 846A–02
(Micro–8)**

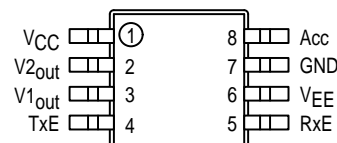

(Top View)

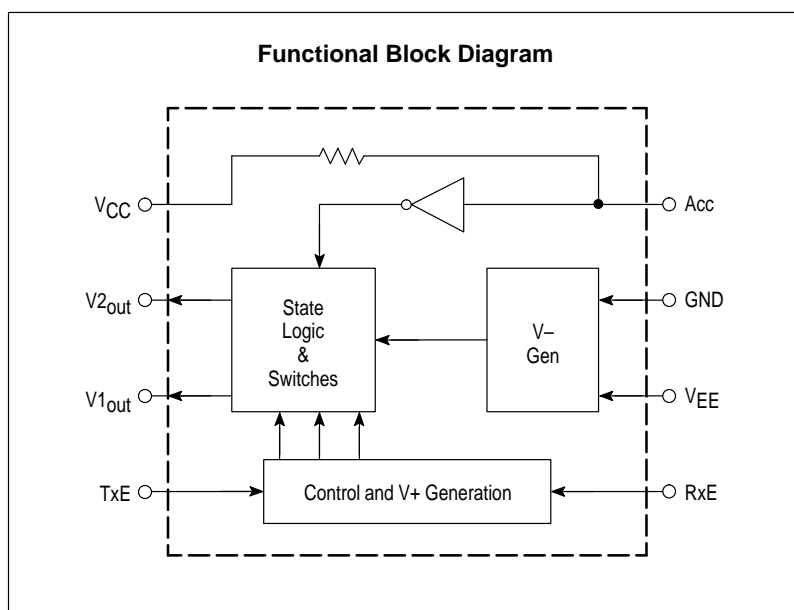

This document contains information on a product under development. Motorola reserves the right to change or discontinue this product without notice.

MDC5100

ABSOLUTE MAXIMUM RATINGS

Rating	Symbol	Value	Unit
Positive Supply Voltage	V_{CC}	6	V
Negative Supply Voltage	$ V_{EE} $	12	V
Differential Supply Voltage	$V_{CC}-V_{EE}$	15	V
Voltage Range at Any Input Pin (TxE, RxE, Acc)	V_{in}	-1 to V_{CC}	V
Junction Temperature	T_J	150	°C
Storage Temperature Range	T_{stg}	-65 to +150	°C

THERMAL CHARACTERISTICS

Characteristic	Symbol	Value	Unit
Total Power Dissipation Derate above 25°C	P_D	510 4	mW mW/°C
Thermal Resistance, Junction to Ambient	$R_{\theta JA}$	245	°C/W

DEVICE MARKING

5100

ORDERING INFORMATION

MDC5100R2	13 inch Reel, 4000 units
-----------	--------------------------

TRUTH TABLE

Input Logic			Output Logic		
RxE	TxE	ACC	V1 _{out}	V2 _{out}	
0	0	0	GND	GND	
0	0	1	GND	GND	
0	1	0	V-	V+	
0	1	1	V+	V-	
1	0	0	V+	V-	
1	0	1	V-	V+	
1	1	0	V+	V+	
1	1	1	V+	V+	

Note 1: ACC "0" = Open, ACC "1" = 10 k Ω to GND

Note 2: V+ is nominally $V_{IH} - 0.1$

Note 3: V- is nominally $V_{EE} - 1$ V

PIN DESCRIPTION

Pin	Name	Functional Description
1	V_{CC}	Positive Supply
2	V2 _{out}	Antenna Control Output 1, V+ is referenced to the V_{IH} of TxE, RxE and V- is referenced to the V_{EE} Voltage
3	V1 _{out}	Antenna Control Output 2, V+ is referenced to the V_{IH} of TxE, RxE and V- is referenced to the V_{EE} Voltage
4	TxE	Transmit Enable Input
5	RxE	Receive Enable Input
6	V_{EE}	Negative Supply
7	GND	Ground
8	Acc	Accessory Present Input

ELECTRICAL CHARACTERISTICS ($V_{CC} = 2.75\text{ V}$, $V_{EE} = -10\text{ V}$, $T_A = 25^\circ\text{C}$)

Characteristic	Symbol	Min	Typ	Max	Unit
----------------	--------	-----	-----	-----	------

RECOMMENDED OPERATING CONDITIONS

Positive Supply Voltage	V_{CC}	1.8		5.0	V
Negative Supply Voltage	V_{EE}	-10		-5.0	V
Voltage Range at Any Input Pin (TxE, RxE, Acc)	V_{in}	0		V_{CC}	V
Ambient Operating Temperature Range	T_A	-40		85	$^\circ\text{C}$

DC ELECTRICAL CHARACTERISTICS

Positive Supply Current (Acc connected to GND) Negative Supply Current (Acc, V1, V2 unterminated)	I_{CC} I_{EE}	100	400	500 -200	μA
RxE or TxE Input High State for V1 or V2 = V+ RxE or TxE Input Low State for V1 or V2 = V-	V_{IH} V_{IL}	2.65		0.4	V
V1, V2 Output High State – TxE or RxE = V_{IH} , $I_{OH} = -25\ \mu\text{A}$ (1) V1, V2 Output Low State – TxE or RxE = V_{IL} , $I_{OL} = 25\ \mu\text{A}$ (1)	V+ V-	2.50		-5.75	V
Accessory Resistance for V1 = V-, V2 = V+ (TxE = V_{IH} , RxE = V_{IL}) Accessory Resistance for V1 = V+, V2 = V- (TxE = V_{IH} , RxE = V_{IL})	Racc Racc	800		12	$\text{k}\Omega$

AC ELECTRICAL CHARACTERISTICS

Propagation Delay – RxE/TxE to V1/V2 (Racc = 800 k Ω to GND)	T_{PLH} (2) T_{PHL} (2)	0.016 0.004		0.5 1.4	μsec μsec
Propagation Delay – RxE/TxE to V1/V2 (Racc = 12 k Ω to GND)	T_{PLH} T_{PHL}	0.35 0.005		4.0 1.4	μsec μsec
Propagation Delay – Acc to V1/V2 through 12 k Ω	T_{PLH} T_{PHL}	0.4 0.1		7.5 5.0	μsec μsec
Transition Time of V1/V2 from RxE or TxE (Racc = 800 k to GND)	T_{rise} (3) T_{fall} (3)	0.3 0.3		7.4 4.4	μsec μsec
Transition Time of V1/V2 from RxE or TxE (Racc = 12 k to GND)	T_{rise} T_{fall}	0.3 0.2		16 4.0	μsec μsec
Transition Time of V1/V2 from Acc Input	T_{rise} T_{fall}	0.3 0.3		4.1 4.1	μsec μsec

NOTES: 1 Refer to truth table for input test states

2. T_{PLH} and T_{PHL} are measured from the 50% point of input waveform to 50% of the output waveform

3. T_{rise} and T_{fall} are measured from the 10% point to the 90% point of the output

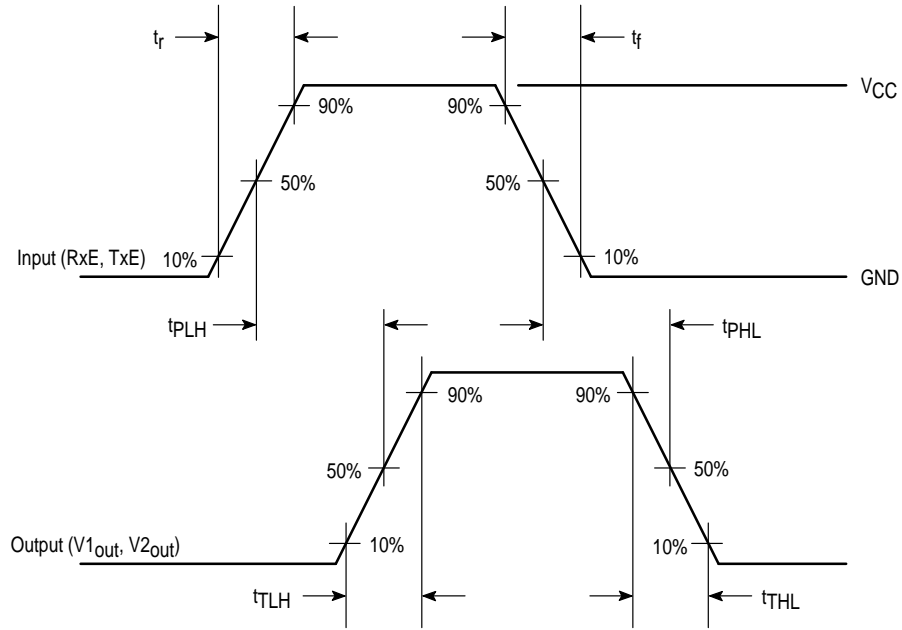

Figure 1.

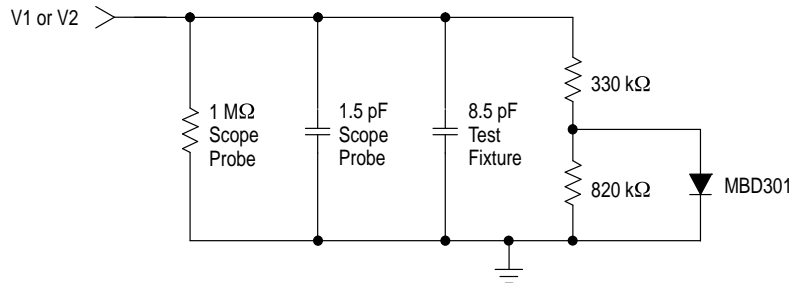

Figure 2. AC Test Load

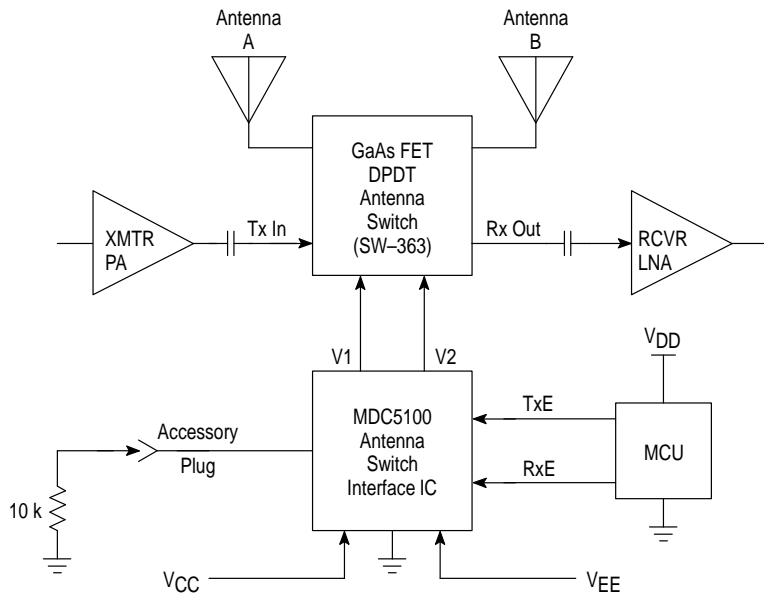

Figure 3. Diversity Antenna Application

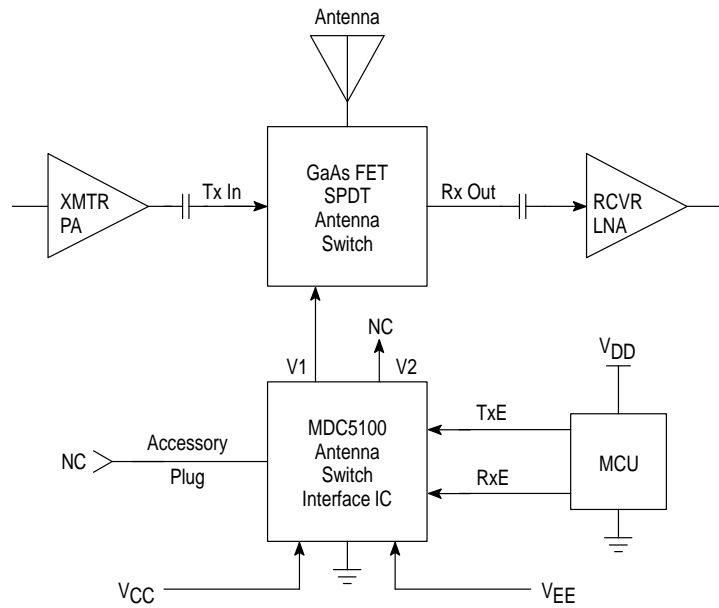
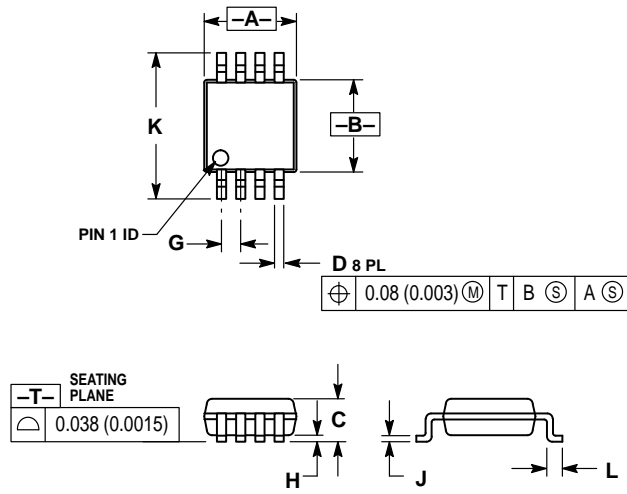

Figure 4. TDD or Half-Duplex Handie-Talkie Application

PACKAGE DIMENSIONS



- NOTES:
1. DIMENSIONING AND TOLERANCING PER ANSI Y14.5M, 1982.
 2. CONTROLLING DIMENSION: MILLIMETER.
 3. DIMENSION A DOES NOT INCLUDE MOLD FLASH, PROTRUSIONS OR GATE BURRS. MOLD FLASH, PROTRUSIONS OR GATE BURRS SHALL NOT EXCEED 0.15 (0.006) PER SIDE.
 4. DIMENSION B DOES NOT INCLUDE INTERLEAD FLASH OR PROTRUSION. INTERLEAD FLASH OR PROTRUSION SHALL NOT EXCEED 0.25 (0.010) PER SIDE.

DIM	MILLIMETERS		INCHES	
	MIN	MAX	MIN	MAX
A	2.90	3.10	0.114	0.122
B	2.90	3.10	0.114	0.122
C	—	1.10	—	0.043
D	0.25	0.40	0.010	0.016
G	0.65 BSC		0.026 BSC	
H	0.05	0.15	0.002	0.006
J	0.13	0.23	0.005	0.009
K	4.75	5.05	0.187	0.199
L	0.40	0.70	0.016	0.028

CASE 846A-02
ISSUE D

NOTES

Motorola reserves the right to make changes without further notice to any products herein. Motorola makes no warranty, representation or guarantee regarding the suitability of its products for any particular purpose, nor does Motorola assume any liability arising out of the application or use of any product or circuit, and specifically disclaims any and all liability, including without limitation consequential or incidental damages. "Typical" parameters which may be provided in Motorola data sheets and/or specifications can and do vary in different applications and actual performance may vary over time. All operating parameters, including "Typicals" must be validated for each customer application by customer's technical experts. Motorola does not convey any license under its patent rights nor the rights of others. Motorola products are not designed, intended, or authorized for use as components in systems intended for surgical implant into the body, or other applications intended to support or sustain life, or for any other application in which the failure of the Motorola product could create a situation where personal injury or death may occur. Should Buyer purchase or use Motorola products for any such unintended or unauthorized application, Buyer shall indemnify and hold Motorola and its officers, employees, subsidiaries, affiliates, and distributors harmless against all claims, costs, damages, and expenses, and reasonable attorney fees arising out of, directly or indirectly, any claim of personal injury or death associated with such unintended or unauthorized use, even if such claim alleges that Motorola was negligent regarding the design or manufacture of the part. Motorola and  are registered trademarks of Motorola, Inc. Motorola, Inc. is an Equal Opportunity/Affirmative Action Employer.

Mfax is a trademark of Motorola, Inc.

How to reach us:

USA/EUROPE/Locations Not Listed: Motorola Literature Distribution;
P.O. Box 5405, Denver, Colorado 80217. 1-303-675-2140 or 1-800-441-2447

JAPAN: Motorola Japan Ltd.; SPD, Strategic Planning Office, 141,
4-32-1 Nishi-Gotanda, Shinagawa-ku, Tokyo, Japan. 81-3-5487-8488

Customer Focus Center: 1-800-521-6274

Mfax™: RMFAX0@email.sps.mot.com – TOUCHTONE 1-602-244-6609
Motorola Fax Back System – US & Canada ONLY 1-800-774-1848
– <http://sps.motorola.com/mfax/>

ASIA/PACIFIC: Motorola Semiconductors H.K. Ltd.; Silicon Harbour Centre,
2, Dai King Street, Tai Po Industrial Estate, Tai Po, N.T., Hong Kong.
852-26668334

HOME PAGE: <http://motorola.com/sps/>



MOTOROLA

