

General Description

The MDH3331 uses advanced MagnaChip's Trench MOSFET Technology to provide high performance in on-state resistance, switching performance and reliability.

Low $R_{DS(ON)}$, Low Gate Charge can be offering superior benefit in the application.

Features

- $V_{DS} = -20V$
- $I_D = -3.5 @ V_{GS} = -10V$
- $R_{DS(ON)} < 75m\Omega @ V_{GS} = -4.5V$
- $< 105m\Omega @ V_{GS} = -2.5V$

Applications

- PWM
- Load Switch
- General Purpose

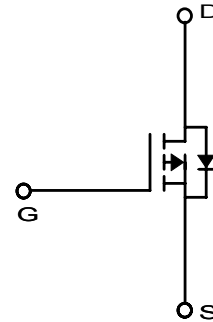
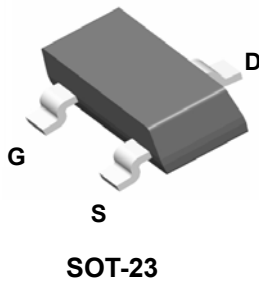

Absolute Maximum Ratings ($T_C = 25^\circ C$ unless otherwise noted)

Characteristics	Symbol	Rating	Unit
Drain-Source Voltage	V_{DSS}	-20	V
Gate-Source Voltage	V_{GSS}	± 12	V
Continuous Drain Current (Note 1)	I_D	-3.5	A
Pulsed Drain Current	I_{DM}	-15	A
Power Dissipation	P_D	1.4	W
Junction and Storage Temperature Range	T_J, T_{stg}	-55~+150	$^\circ C$

Thermal Characteristics

Characteristics	Symbol	Rating	Unit
Thermal Resistance, Junction-to-Ambient (Note 1)	$R_{\theta JA}$	90	$^\circ C/W$
Thermal Resistance, Junction-to-Case	$R_{\theta JC}$	60	

Ordering Information

Part Number	Temp. Range	Package	Packing	RoHS Status
MDH3331RH	-55~150°C	SOT-23	Tape & Reel	Halogen Free
MDH3331RP	-55~150°C	SOT-23	Tape & Reel	Pb Free

Electrical Characteristics (T_J = 25°C unless otherwise noted)

Characteristics	Symbol	Test Condition	Min	Typ	Max	Unit
Static Characteristics						
Drain-Source Breakdown Voltage	BV _{DSS}	I _D = -250μA, V _{GS} = 0V	-20	-	-	V
Gate Threshold Voltage	V _{GS(th)}	V _{DS} = V _{GS} , I _D = -250μA	-0.4	-0.9	-1.5	
Zero Gate Voltage Drain Current	I _{DSS}	V _{DS} = -16 V, V _{GS} = 0V	-	-	-1	μA
Gate Leakage Current	I _{GSS}	V _{GS} = ±12 V, V _{DS} = 0V	-	-	±0.1	
Drain-Source ON Resistance	R _{DS(ON)}	V _{GS} = -4.5V, I _D = -3.5A	-	55	75	mΩ
		V _{GS} = -2.5V, I _D = -3A	-	81	105	
Forward Transconductance	g _{FS}	V _{DS} = -4.5V, I _D = -3.5A	-	11.8	-	S
Dynamic Characteristics						
Total Gate Charge	Q _g	V _{DD} = -10V, I _D = -3.5A, V _{GS} = -4.5V	-	7	-	nC
Gate-Source Charge	Q _{gs}		-	1.3	-	
Gate-Drain Charge	Q _{gd}		-	2	-	
Input Capacitance	C _{iss}	V _{DS} = -10V, V _{GS} = 0V, f = 1.0MHz	-	472	-	pF
Reverse Transfer Capacitance	C _{rss}		-	67	-	
Output Capacitance	C _{oss}		-	101	-	
Turn-On Delay Time	t _{d(on)}	V _{GS} = -10V, V _{DD} = -10V, I _D = -3.5A, R _{GEN} = 3Ω	-	3.0	-	ns
Turn-On Rise Time	t _r		-	24.8	-	
Turn-Off Delay Time	t _{d(off)}		-	30	-	
Turn-Off Fall Time	t _f		-	11.8	-	
Drain-Source Body Diode Characteristics						
Source-Drain Diode Forward Voltage	V _{SD}	I _S = -3.5A, V _{GS} = 0V	-	-	1.2	V
Reverse Recovery Time	t _{rr}	I _S = -3.5A, di/dt = 100A/us	-	35.9	-	ns
Reverse Recovery Charge	Q _{rr}		-	17.8	-	nC

Note :

1. Surface mounted RF4 board with 2oz. Copper.

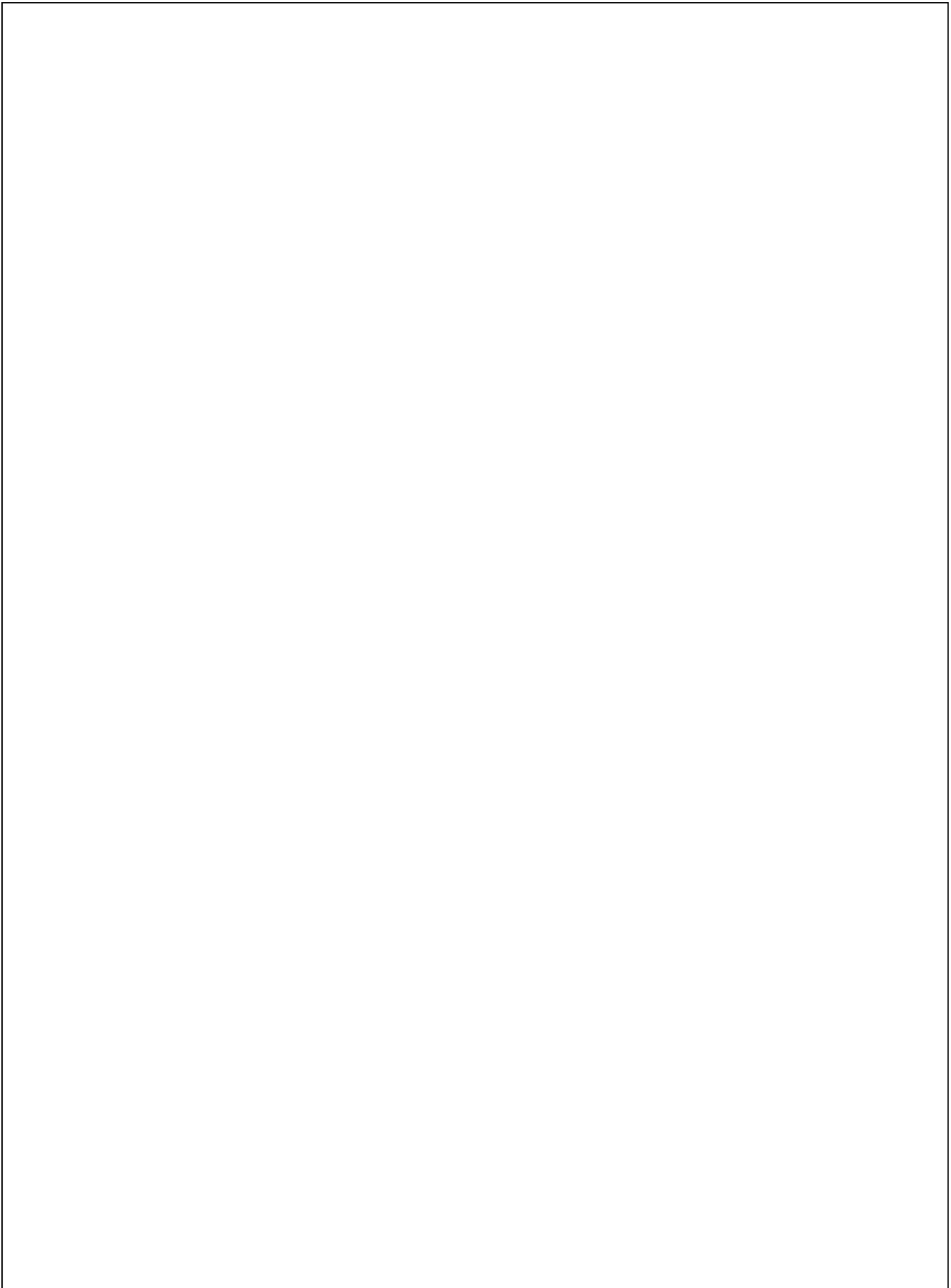

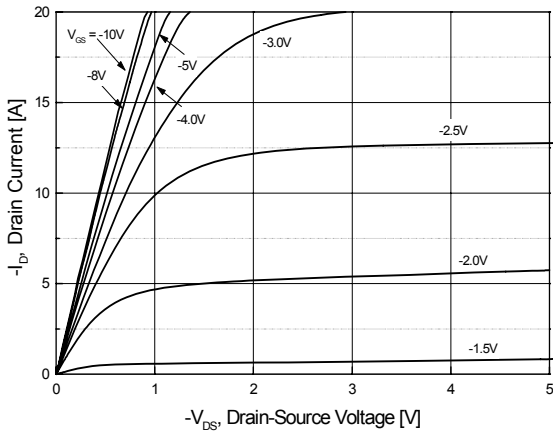

Fig.1 On-Region Characteristics

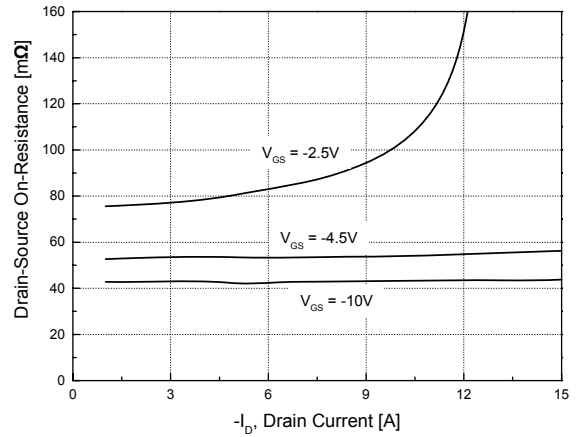

Fig.2 On-Resistance Variation with Drain Current and Gate Voltage

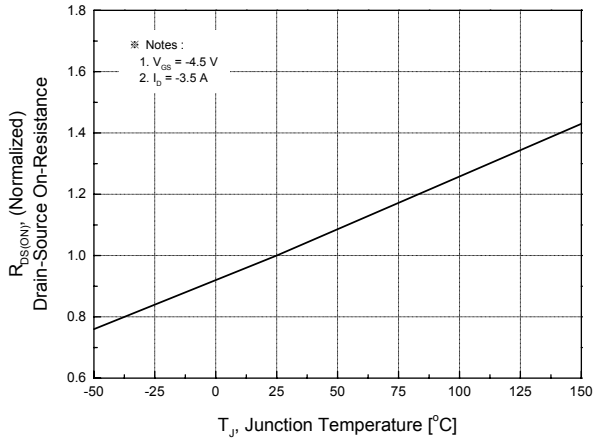

Fig.3 On-Resistance Variation with Temperature

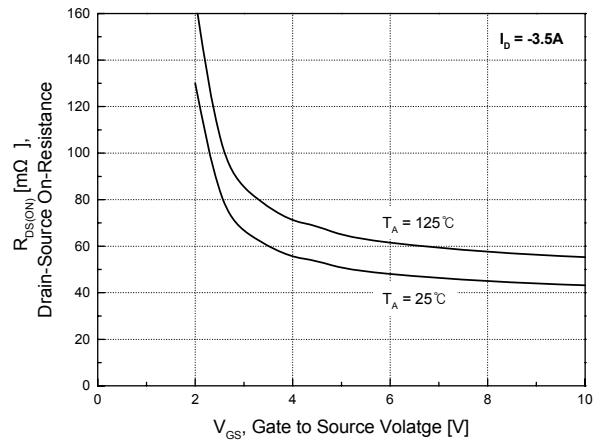

Fig.4 On-Resistance Variation with Gate to Source Voltage

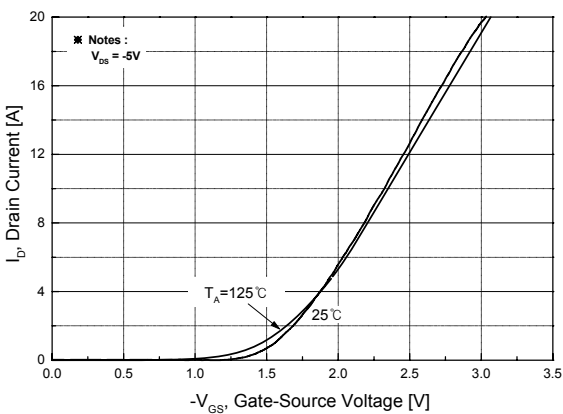

Fig.5 Transfer Characteristics

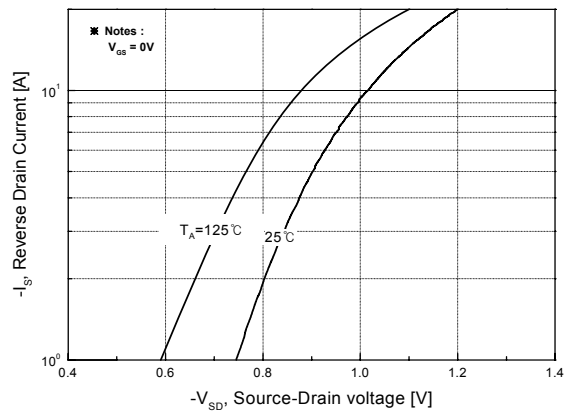

Fig.6 Body Diode Forward Voltage Variation with Source Current and Temperature

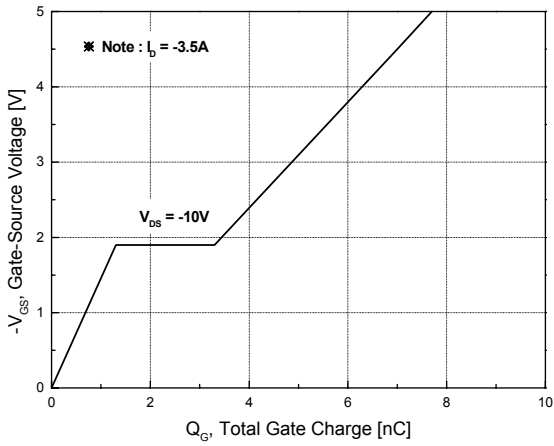

Fig.7 Gate Charge Characteristics

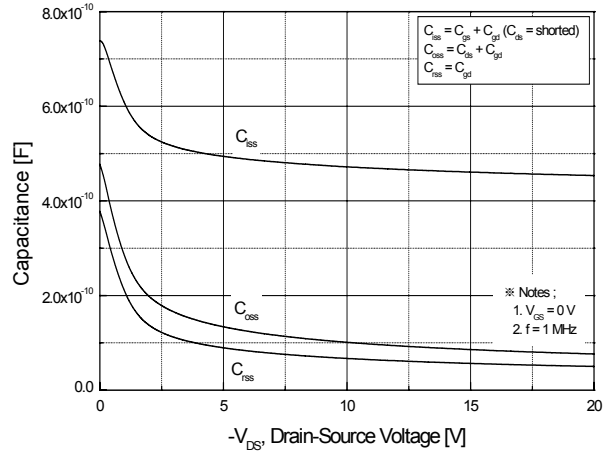

Fig.8 Capacitance Characteristics

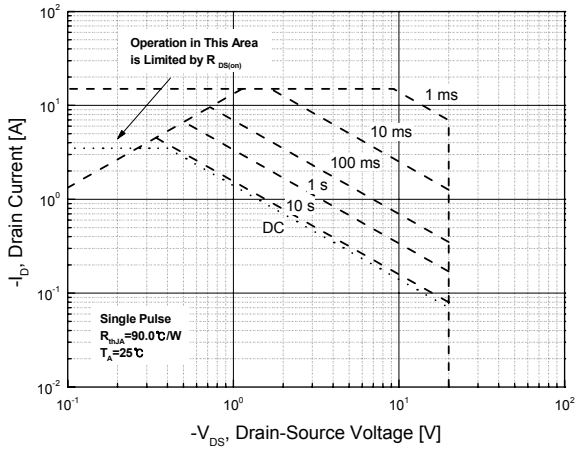

Fig.9 Maximum Safe Operating Area

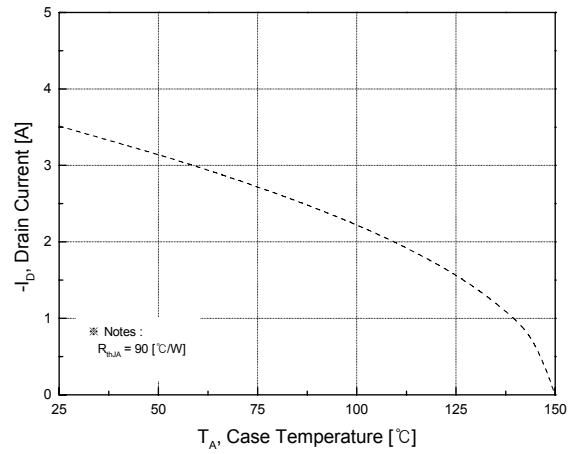

Fig.10 Maximum Drain Current vs. Case Temperature

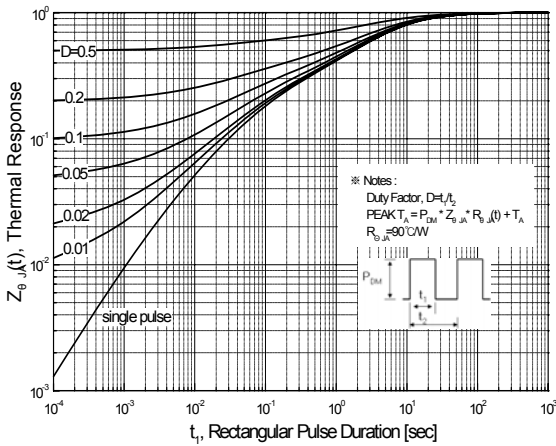
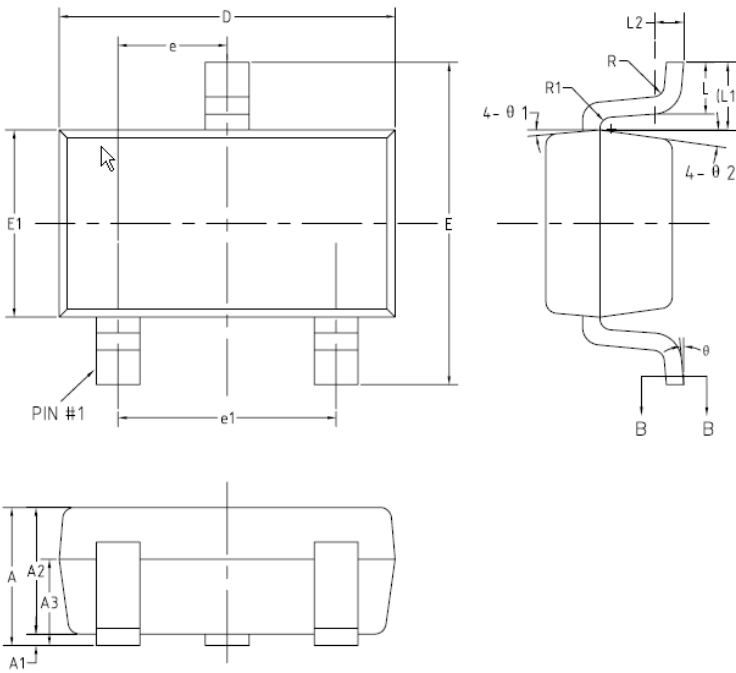

Fig.11 Transient Thermal Response Curve

Physical Dimensions

3 Leads, SOT-23

Dimensions are in millimeters unless otherwise specified



COMMON DIMENSIONS
(UNITS OF MEASURE=MILLIMETER)

SYMBOL	MIN	NOM	MAX
A	—	—	1.25
A1	0	—	0.15
A2	1.00	1.10	1.20
A3	0.60	0.65	0.70
b	0.36	—	0.50
b1	0.36	0.38	0.45
c	0.14	—	0.20
c1	0.14	0.15	0.16
D	2.826	2.926	3.026
E	2.60	2.80	3.00
E1	1.526	1.626	1.726
e	0.95BSC		
e1	1.90BSC		
L	0.35	0.45	0.60
L1	0.59REF		
L2	0.25BSC		
R	0.05	—	—
R1	0.05	—	0.20
θ	0°	—	8°
θ 1	3°	5°	7°
θ 2	6°	8°	10°

Worldwide Sales Support Locations

U.S.A

Sunnyvale Office

787 N. Mary Ave. Sunnyvale
CA 94085 U.S.A
Tel : 1-408-636-5200
Fax : 1-408-213-2450
E-Mail : usasales@magnachip.com

U.K

Knyvett House The Causeway,
Staines Middx, TW18 3BA,U.K.
Tel : +44 (0) 1784-895-000
Fax : +44 (0) 1784-895-115
E-Mail : uksales@magnachip.com

Japan

Osaka Office

3F, Shin-Osaka MT-2 Bldg 3-5-36
Miyahara Yodogawa-Ku
Osaka, 532-0003 Japan
Tel : 81-6-6394-9160
Fax : 81-6-6394-9150
E-Mail : osakasales@magnachip.com

Taiwan R.O.C

2F, No.61, Chowize Street, Nei Hu
Taipei, 114 Taiwan R.O.C
Tel : 886-2-2657-7898
Fax : 886-2-2657-8751
E-Mail : taiwansales@magnachip.com

China

Hong Kong Office

Suite 1024, Ocean Centre 5 Canton Road,
Tsim Sha Tsui Kowloon, Hong Kong
Tel : 852-2828-9700
Fax : 852-2802-8183
E-Mail : chinasales@magnachip.com

Shenzhen Office

Room 1803, 18/F
International Chamber of Commerce Tower
Fuhua Road3 CBD, Futian District, China
Tel : 86-755-8831-5561
Fax : 86-755-8831-5565
E-Mail : chinasales@magnachip.com

Shanghai Office

Room E, 8/F, Liaoshen International Building 1068
Wuzhong Road, (C) 201103
Shanghai, China
Tel : 86-21-6405-1521
Fax : 86-21-6505-1523
E-Mail : chinasales@magnachip.com

Korea

891, Daechi-Dong, Kangnam-Gu
Seoul, 135-738 Korea
Tel : 82-2-6903-3451
Fax : 82-2-6903-3668 ~9
Email : koreasales@magnachip.com

DISCLAIMER:

The Products are not designed for use in hostile environments, including, without limitation, aircraft, nuclear power generation, medical appliances, and devices or systems in which malfunction of any Product can reasonably be expected to result in a personal injury. Seller's customers using or selling Seller's products for use in such applications do so at their own risk and agree to fully defend and indemnify Seller.

MagnaChip reserves the right to change the specifications and circuitry without notice at any time. MagnaChip does not consider responsibility for use of any circuitry other than circuitry entirely included in a MagnaChip product. [MagnaChip](#) is a registered trademark of MagnaChip Semiconductor Ltd.