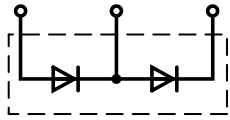
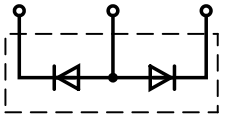
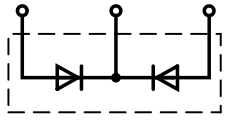

Dual Diode Modules

MD#630-30N2 & MD#630-36N2

Absolute Maximum Ratings

V_{RRM} [V]	 MDD	 MDA	 MDK
1200	630-30N2	630-30N2	630-30N2
1800	630-36N2	630-36N2	630-36N2

	VOLTAGE RATINGS	MAXIMUM LIMITS	UNITS
V_{RRM}	Repetitive peak reverse voltage ¹⁾	3000-3600	V
V_{RSM}	Non-repetitive peak reverse voltage ¹⁾	3100-3700	V

	OTHER RATINGS	MAXIMUM LIMITS	UNITS
$I_{F(AV)M}$	Maximum average on-state current, $T_C = 85^\circ\text{C}$ ²⁾	630	A
$I_{F(AV)M}$	Maximum average on-state current. $T_C = 100^\circ\text{C}$ ²⁾	530	A
$I_{F(RMS)M}$	Nominal RMS on-state current, $T_C = 55^\circ\text{C}$ ²⁾	1275	A
$I_{F(d.c.)}$	D.C. on-state current, $T_C = 55^\circ\text{C}$	1090	A
I_{FSM}	Peak non-repetitive surge $t_p = 10$ ms, $V_{RM} = 60\%V_{RRM}$ ³⁾	11.7	kA
I_{FSM2}	Peak non-repetitive surge $t_p = 10$ ms, $V_{RM} \leq 10$ V ³⁾	13.0	kA
I^2t	I^2t capacity for fusing $t_p = 10$ ms, $V_{RM} = 60\%V_{RRM}$ ³⁾	845×10^3	A^2s
I^2t	I^2t capacity for fusing $t_p = 10$ ms, $V_{RM} \leq 10$ V ³⁾	684×10^3	A^2s
V_{ISOL}	Isolation Voltage ⁴⁾	3000	V
$T_{vj\text{ op}}$	Operating temperature range	-40 to +150	$^\circ\text{C}$
T_{stg}	Storage temperature range	-40 to +150	$^\circ\text{C}$

Notes:

- 1) De-rating factor of 0.13% per $^\circ\text{C}$ is applicable for T_{vj} below 25°C .
- 2) Single phase; 50 Hz, 180° half-sinewave.
- 3) Half-sinewave, 150°C T_{vj} initial.
- 4) AC RMS voltage, 50 Hz, 1min test

Characteristics

	PARAMETER	MIN.	TYP.	MAX.	TEST CONDITIONS ¹⁾	UNITS
V _{FM}	Maximum peak forward voltage	-	-	1.20	I _{FM} = 800 A	V
V _{FM}	Maximum peak forward voltage	-	-	1.80	I _{FM} = 2000 A	V
V _{To}	Threshold voltage	-	-	0.80		V
r _T	Slope resistance	-	-	0.50		mΩ
I _{R_{RRM}}	Peak reverse current	-	-	50	Rated V _{R_{RRM}}	mA
Q _{rr}	Recovered Charge	-	2900	3200	I _{TM} = 500A, t _p = 1ms, di/dt = 10A/μs, V _R = 100 V	μC
Q _{ra}	Recovered Charge, 50% chord	-	2560	-		μC
I _{rm}	Reverse recovery current	-	150	-		A
t _{rr}	Reverse recovery time, 50% chord	-	34	-		μs
R _{thJC}	Thermal resistance, junction to case	-	-	0.0650	Single Diode	K/W
		-	-	0.0325	Whole Module	K/W
R _{thCH}	Thermal resistance, case to heatsink	-	-	0.02	Single Diode	K/W
		-	-	0.01	Whole Module	K/W
F ₁	Mounting force (to heatsink) ²⁾	5.1	-	6.9		Nm
F ₂	Mounting force (to terminals) ²⁾	10.2	-	13.8		Nm
W _t	Weight	-	1.5	-		kg

Notes:

- 1) Unless otherwise indicated T_{vj} = 150°C.
- 2) Screws must be lubricated.

Notes on Ratings and Characteristics

1.0 Voltage Grade Table

Voltage Grade	V_{RRM} V	V_{RSM} V	V_R DC V
3000	3000	3100	2250
3600	3600	3700	2700

2.0 Extension of Voltage Grades

This report is applicable to other voltage grades when supply has been agreed by Sales/Production.

3.0 De-rating Factor

A blocking voltage de-rating factor of 0.13%/°C is applicable to this device for T_{vj} below 25°C.

4.0 Snubber Components

When selecting snubber components, care must be taken not to use excessively large values of snubber capacitor or excessively small values of snubber resistor. Such excessive component values may lead to device damage due to the large resultant values of snubber discharge current. If required, please consult the factory for assistance.

5.0 Computer Modelling Parameters

5.1 Thyristor Dissipation Calculations

$$I_{AV} = \frac{-V_{T0} + \sqrt{V_{T0}^2 + 4 \cdot ff^2 \cdot r_T \cdot W_{AV}}}{2 \cdot ff^2 \cdot r_T} \quad \text{and:} \quad W_{AV} = \frac{\Delta T}{R_{th}}$$

$$\Delta T = T_{j \max} - T_K$$

Where $V_{T0} = 0.80$ V, $r_T = 0.50$ mΩ.

R_{th} = Supplementary thermal impedance, see table below and

ff = Form factor, see table below.

Supplementary Thermal Impedance							
Conduction Angle	30°	60°	90°	120°	180°	270°	d.c.
Square wave	0.0798	0.0742	0.0712	0.0694	0.0674	0.0659	0.0650
Sine wave	0.0736	0.0685	0.0667	0.0657	0.0651		

Form Factors							
Conduction Angle	30°	60°	90°	120°	180°	270°	d.c.
Square wave	3.464	2.449	2	1.732	1.414	1.149	1
Sine wave	3.98	2.778	2.22	1.879	1.57		

5.2 Calculating diode V_F using ABCD Coefficients

The forward characteristic I_F vs. V_F , on page 6 is represented by a set of constants A, B, C, D, forming the coefficients of the representative equation for V_F in terms of I_F given below:

$$V_F = A + B \cdot \ln(I_F) + C \cdot I_F + D \cdot \sqrt{I_F}$$

The constants, derived by curve fitting software, are given below for both hot and cold characteristics. The resulting values for V_F agree with the true device characteristic over a current range, which is limited to that plotted.

25°C Coefficients		150°C Coefficients	
A	0.8507456	A	0.4945386
B	0.04762876	B	0.05726181
C	4.08857×10^{-4}	C	4.98169×10^{-4}
D	-3.12768×10^{-3}	D	-2.79389×10^{-3}

5.3 D.C. Thermal Impedance Calculation

$$r_t = \sum_{p=1}^{p=n} r_p \cdot \left(1 - e^{-\frac{t}{\tau_p}} \right)$$

Where $p = 1$ to n and:

- n = number of terms in the series
- t = Duration of heating pulse in seconds
- r_t = Thermal resistance at time t
- r_p = Amplitude of p th term
- τ_p = Time Constant of r_{th} term

The coefficients for this device are shown in the table below:

D.C. Single Diode				
Term	1	2	3	4
r_p	0.03671713	0.01198766	0.01439901	1.895749×10^{-3}
τ_p	3.123905	0.8540715	0.1955971	1.412289×10^{-3}

6.0 Reverse recovery ratings

(i) Q_{ra} is based on 50% I_{RM} chord as shown in Fig. 1

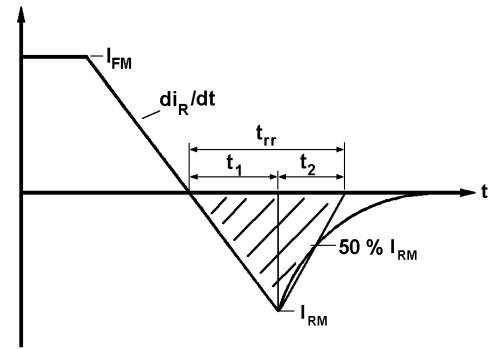

Fig. 1

(ii) Q_{rr} is based on a 150 μs integration time i.e.

$$Q_{rr} = \int_0^{150\mu s} i_{rr} \cdot dt$$

(iii) $K \text{ Factor} = \frac{t_1}{t_2}$

Curves

Figure 1 – Forward characteristics of Limit device

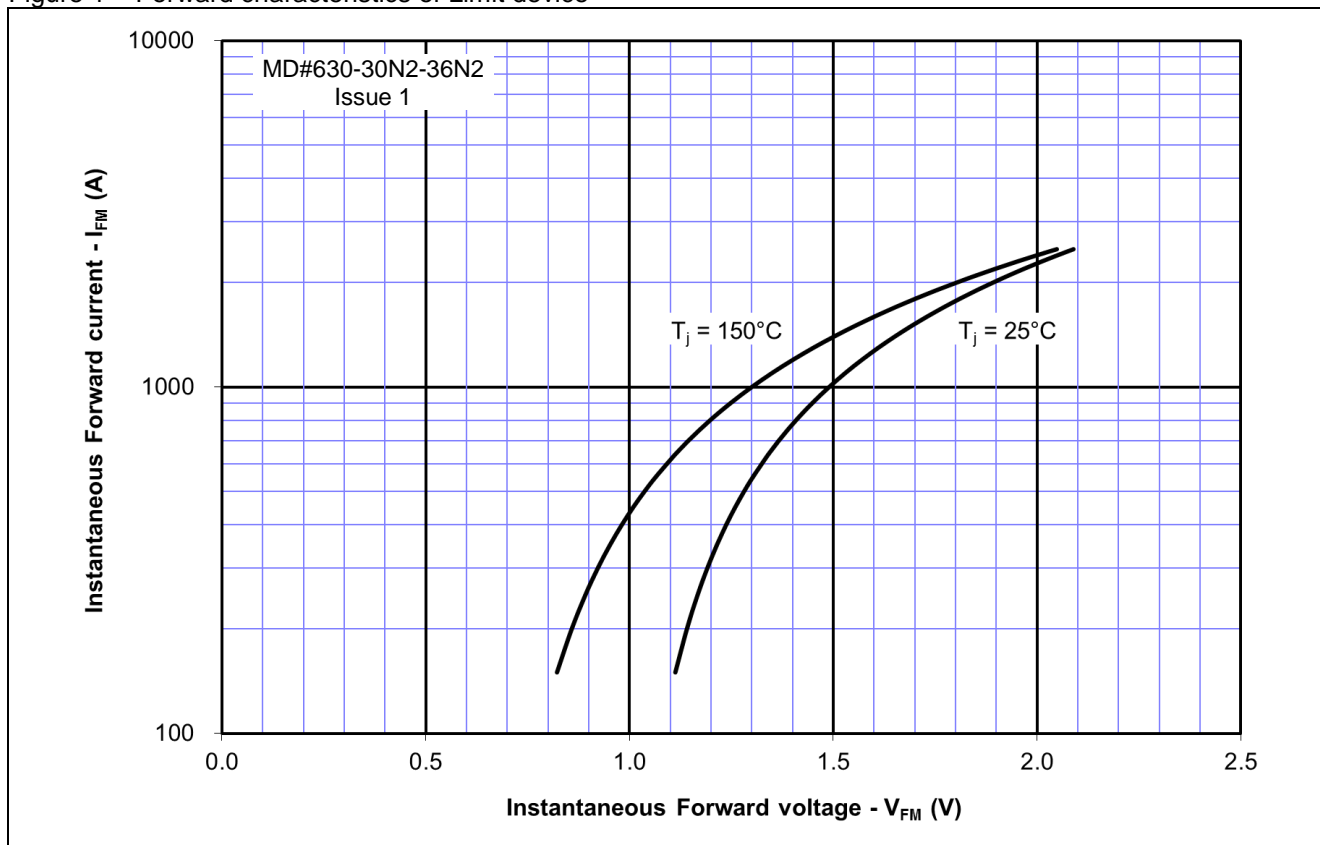

Figure 2 – Maximum surge and I^2t Ratings

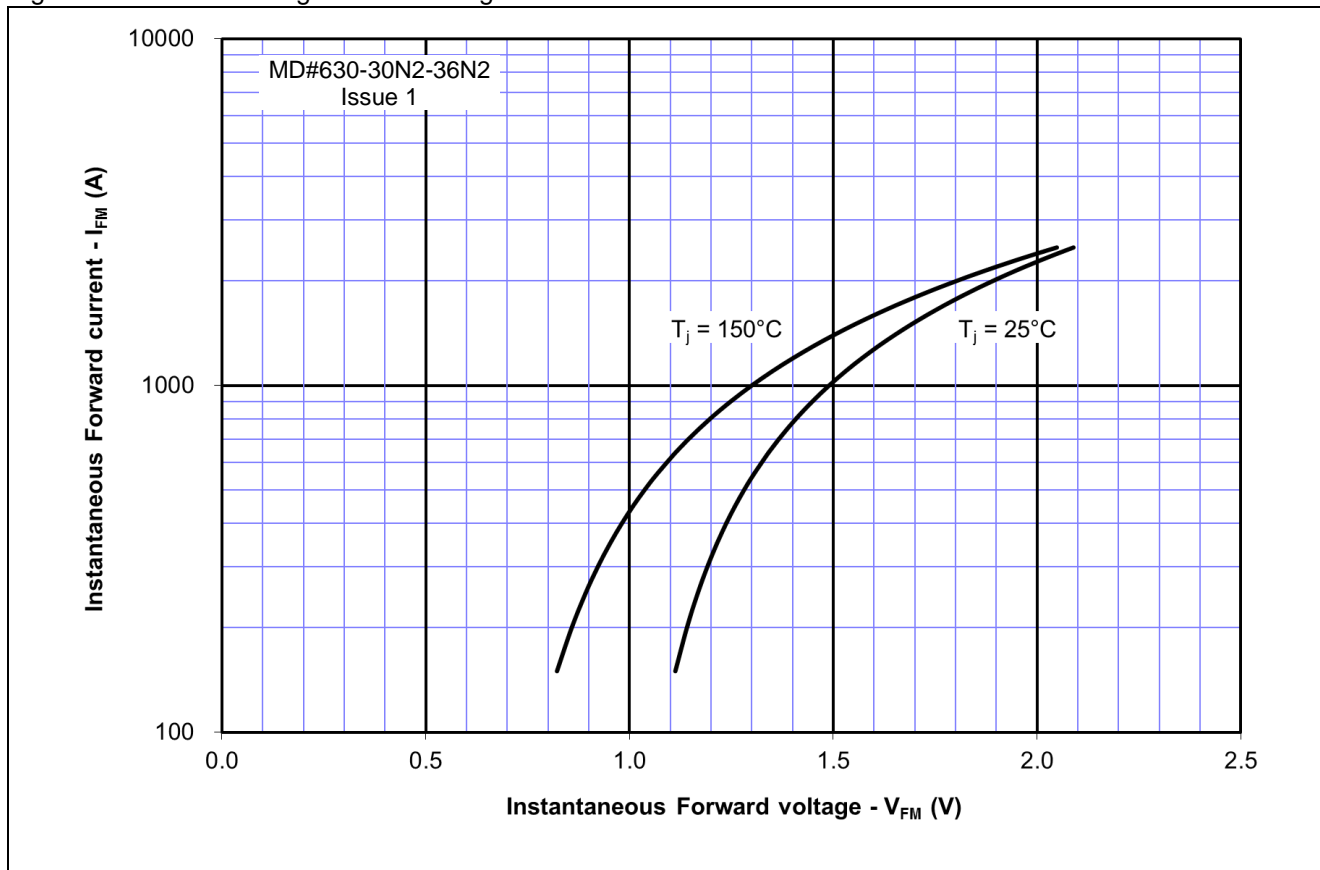

Figure 3 - Total recovered charge, Q_{rr}

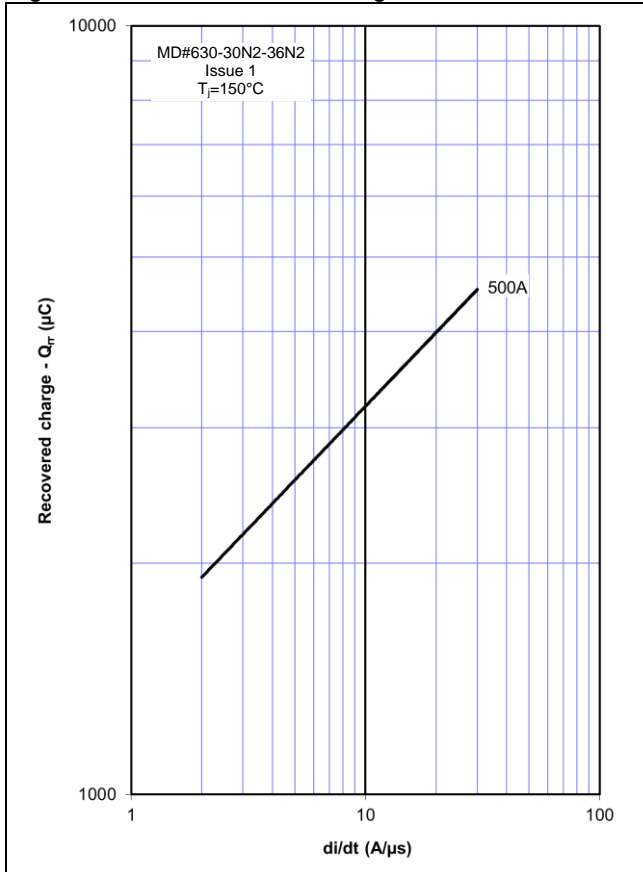

Figure 4 - Recovered charge, Q_{ra} (50% chord)

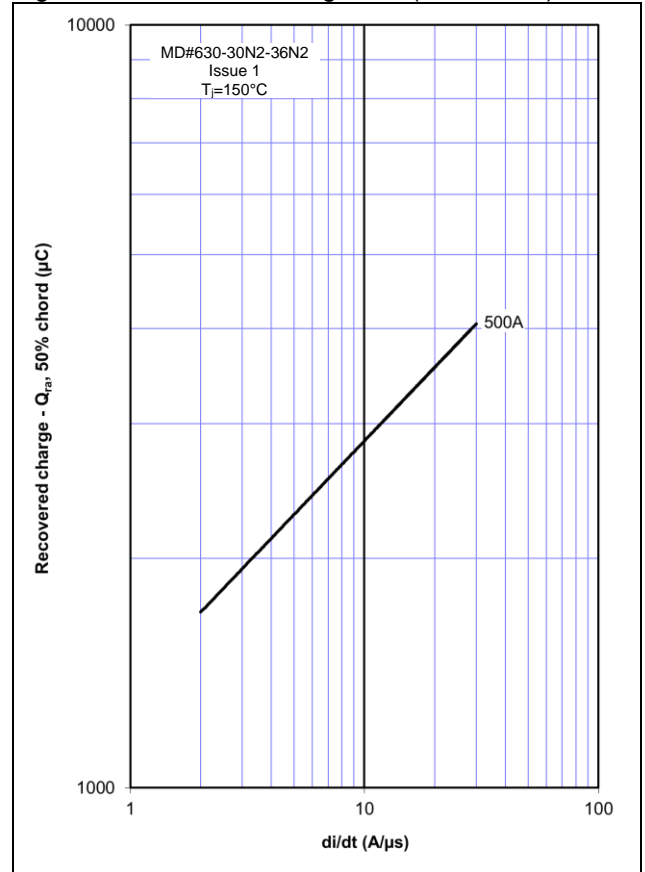

Figure 5 - Peak reverse recovery current, I_{rm}

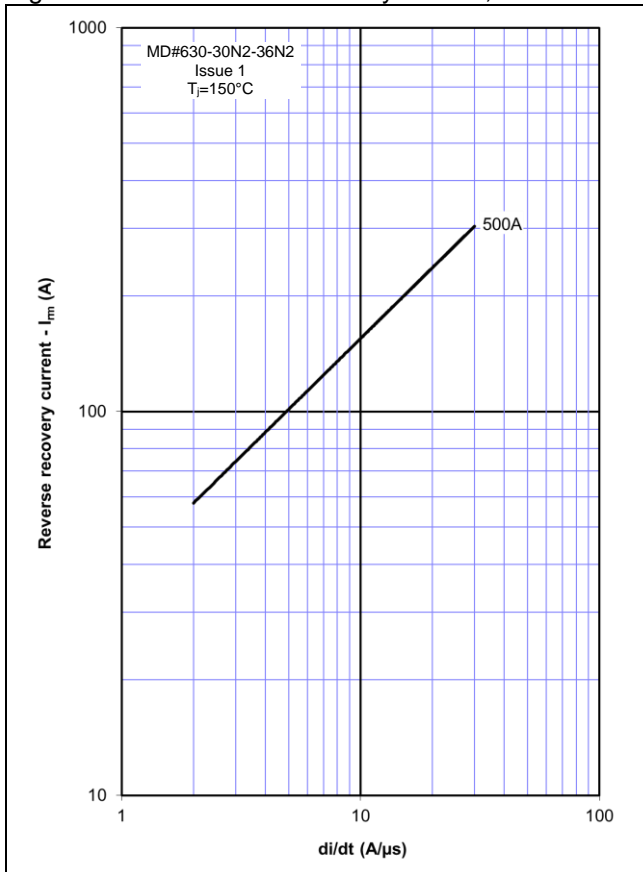

Figure 6 - Maximum recovery time, t_{rr} (50% chord)

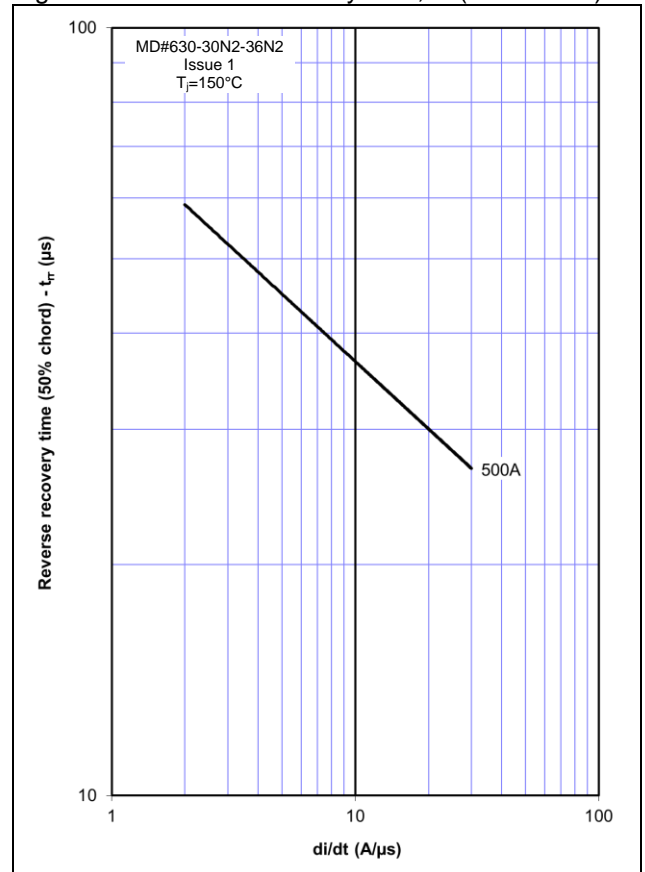

Figure 7 – Forward current vs. Power dissipation

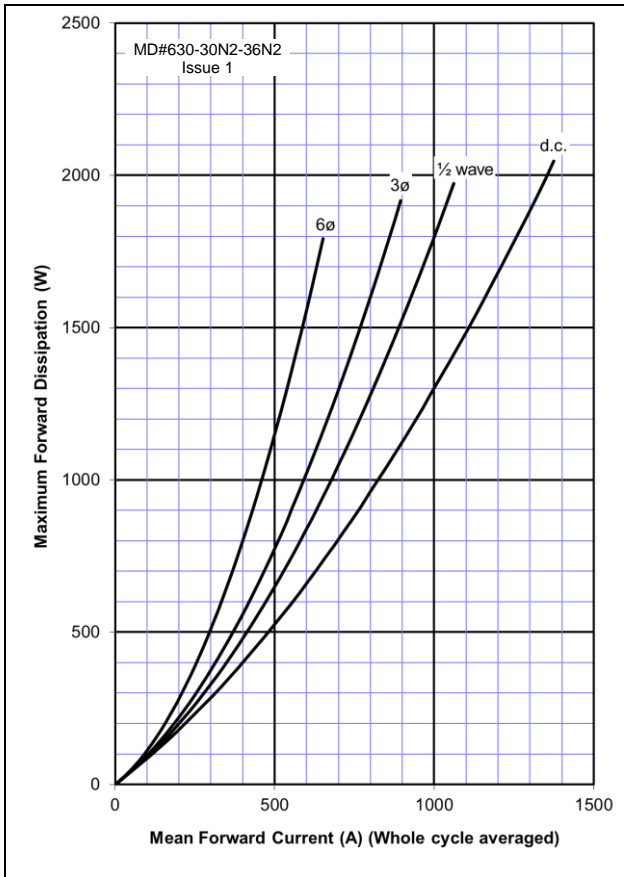

Figure 8 – Forward current vs. Heatsink temperature

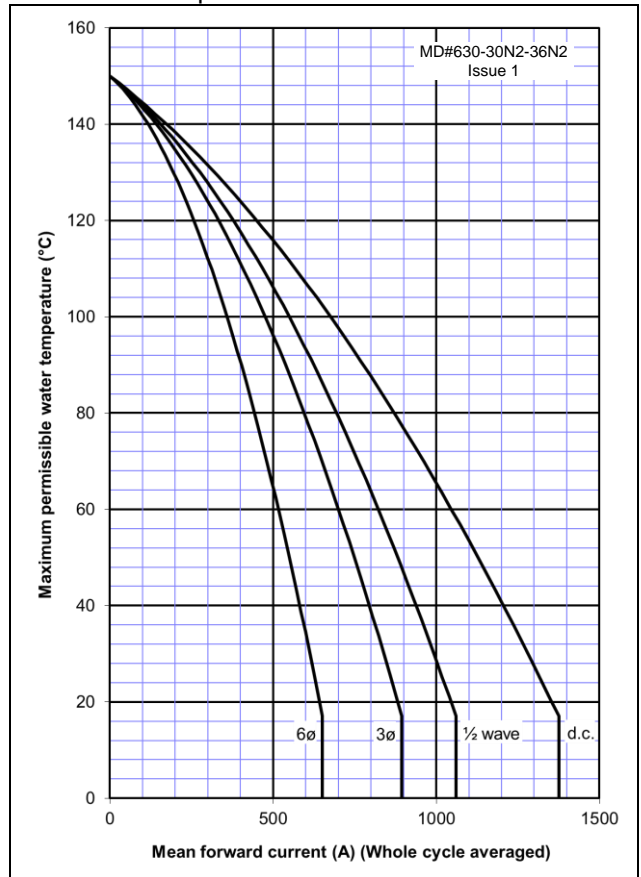
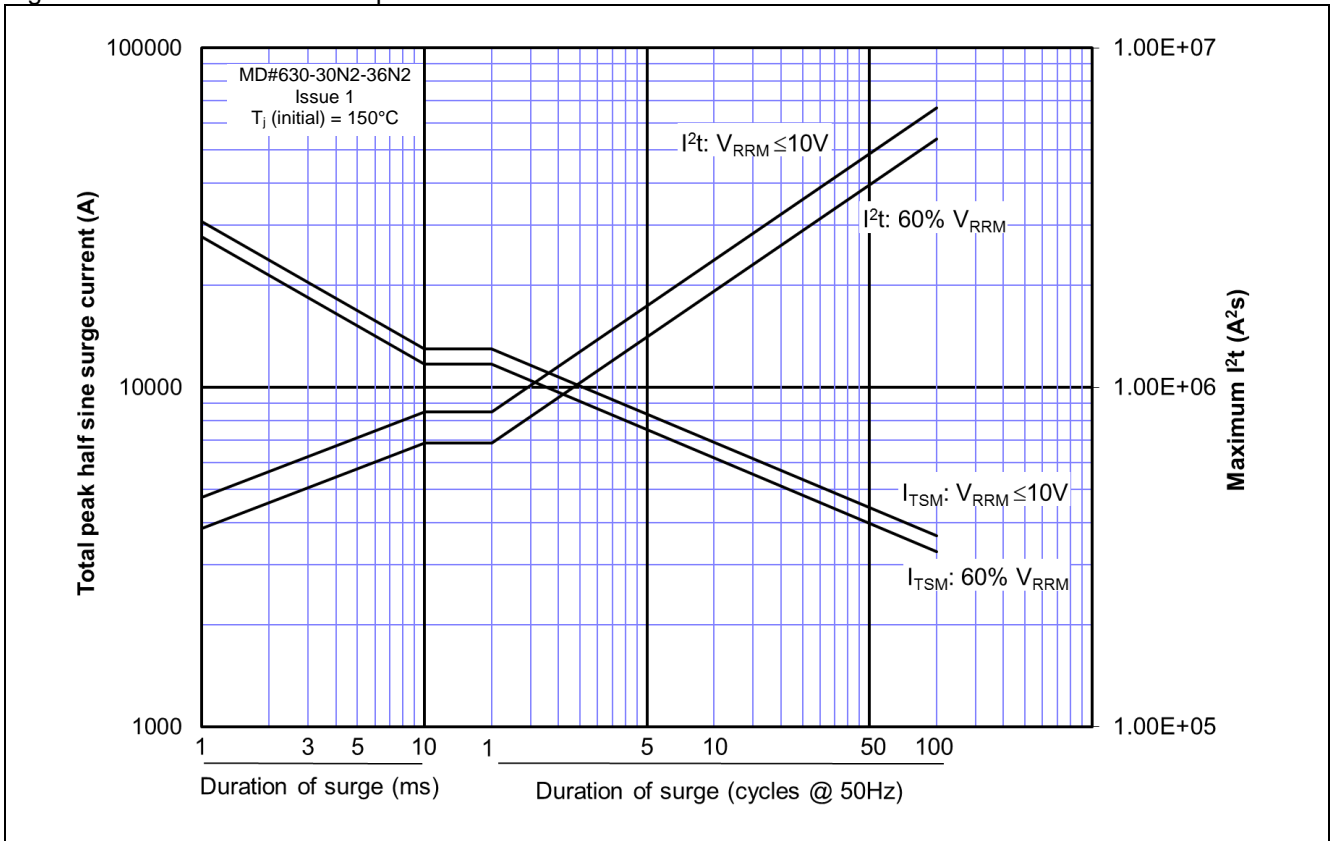
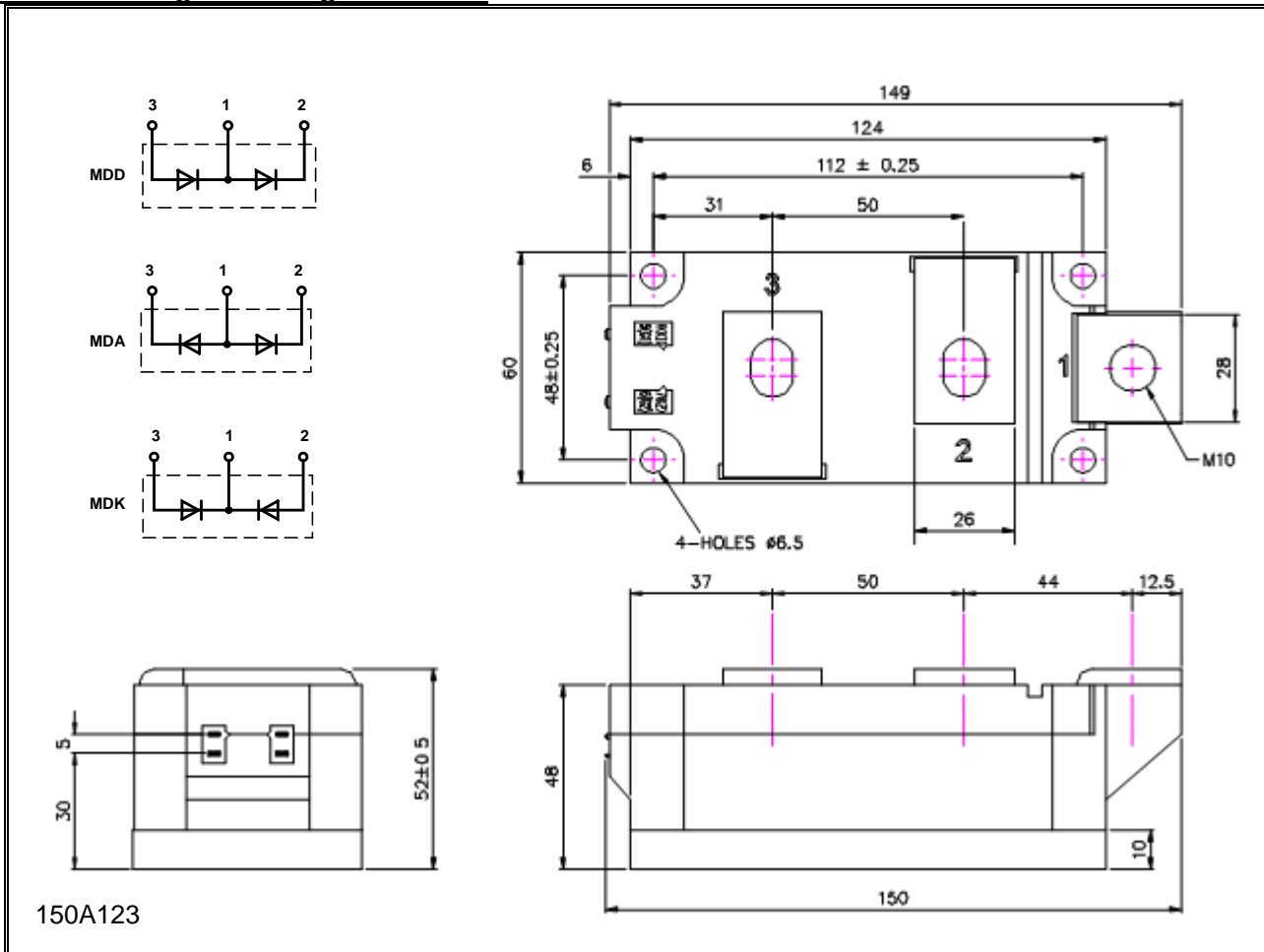

Figure 9 – Transient thermal impedance



Outline Drawing & Ordering Information



150A123

ORDERING INFORMATION

(Please quote 11 digit code as below)

M	D#	630	◆◆	N	2
Fixed Type Code	Configuration code DD, DA, DK	Fixed Type Code	Voltage code V _{RRM} /100 30-36	Standard Diode	Fixed Version Code

Typical order code: MDA630-36N2– MDA configuration, 6600V V_{RRM}

IXYS Semiconductor GmbH
 Edisonstraße 15
 D-68623 Lampertheim
 Tel: +49 6206 503-0
 Fax: +49 6206 503-627
 E-mail: marcom@ixys.de



IXYS UK Westcode Ltd
 Langley Park Way, Langley Park,
 Chippenham, Wiltshire, SN15 1GE.
 Tel: +44 (0)1249 444524
 Fax: +44 (0)1249 659448
 E-mail: sales@ixysuk.com

IXYS Corporation
 1590 Buckeye Drive
 Milpitas CA 95035-7418
 Tel: +1 (408) 457 9000
 Fax: +1 (408) 496 0670
 E-mail: sales@ixys.net

www.ixysuk.com

www.ixys.com

IXYS Long Beach
 IXYS Long Beach, Inc
 2500 Mira Mar Ave, Long Beach
 CA 90815
 Tel: +1 (562) 296 6584
 Fax: +1 (562) 296 6585
 E-mail: service@ixyslongbeach.com

The information contained herein is confidential and is protected by Copyright. The information may not be used or disclosed except with the written permission of and in the manner permitted by the proprietors IXYS UK Westcode Ltd.

© IXYS UK Westcode Ltd.

In the interest of product improvement, IXYS UK Westcode Ltd reserves the right to change specifications at any time without prior notice.

Devices with a suffix code (2-letter, 3-letter or letter/digit/letter combination) added to their generic code are not necessarily subject to the conditions and limits contained in this report.