

Outline

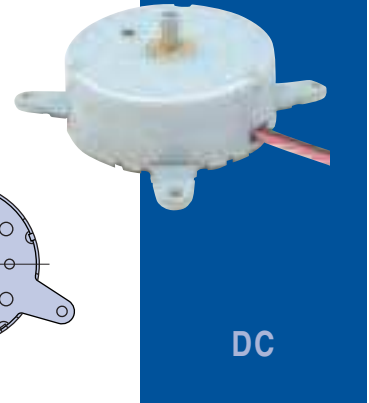
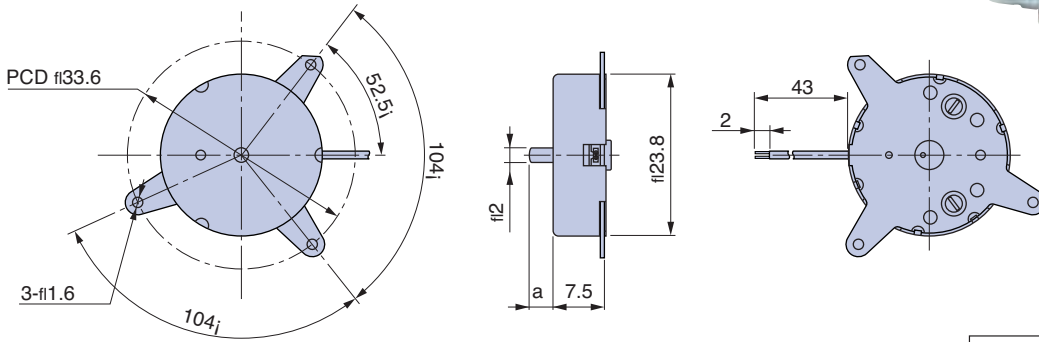

DC

UNIT: mm

Specifications

Model	Operating Voltage (V)	Rated Voltage (V)	No Load Speed (min ⁻¹)	No Load Current (mA)	Rated Load		Rated Load Speed (min ⁻¹)	Rated Load Current (mA)	Starting Torque		Shaft Length (mm)
					(gf·cm)	(mN·m)			(gf·cm)	(mN·m)	
MDN1HL3SDAS	0.7 to 6.0	2	2,150	11	3	0.294	1,360	50	8.2	0.8	a=3.5

Characteristics

