



Features:

- Isolated mounting base 2500V~
- Solder joint technology with Increased power cycling capability
- Space and weight saving

Typical Applications

- Inverter
- Inductive heating
- Chopper

V_{RSM}	V_{RRM}	Type & Outline
900V	800V	MDS150-08-234H5
1100V	1000V	MDS150-10-234H5
1300V	1200V	MDS150-12-234H5
1500V	1400V	MDS150-14-234H5
1700V	1600V	MDS150-16-234H5
1900V	1800V	MDS150-18-234H5

SYMBOL	CHARACTERISTIC	TEST CONDITIONS	$T_j(^{\circ}C)$	VALUE			UNIT
				Min	Type	Max	
I_o	DC output current	Three-phase full wave rectifying circuit, $T_C=100^{\circ}C$	150			150	A
I_{RRM}	Repetitive peak current	at V_{RRM}	150			12	mA
I_{FSM}	Surge forward current	10ms half sine wave	100			1.5	kA
I^2t	I^2t for fusing coordination	$V_R=0$				11.25	$A^2s \cdot 10^3$
V_{FO}	Threshold voltage		150			0.75	V
r_F	Forward slope resistance					2.4	$m\Omega$
V_{FM}	Peak forward voltage	$I_{FM}=150A$	25			1.40	V
$R_{th(j-c)}$	Thermal resistance Junction to case	Single side cooled				0.14	$^{\circ}C/W$
$R_{th(c-h)}$	Thermal resistance case to heatsink	Single side cooled				0.07	$^{\circ}C/W$
V_{iso}	Isolation voltage	50Hz, R.M.S, t=1min, $I_{iso}: 1mA(max)$		2500			V
F_m	Terminal connection torque(M6)				6.0		N·m
	Mounting torque(M6)				6.0		N·m
T_{stg}	Stored temperature			-40		125	$^{\circ}C$
W_t	Weight	221H5/234H5			250		g
		411H5			330		g
Outline	221H5/411H5/234H5						

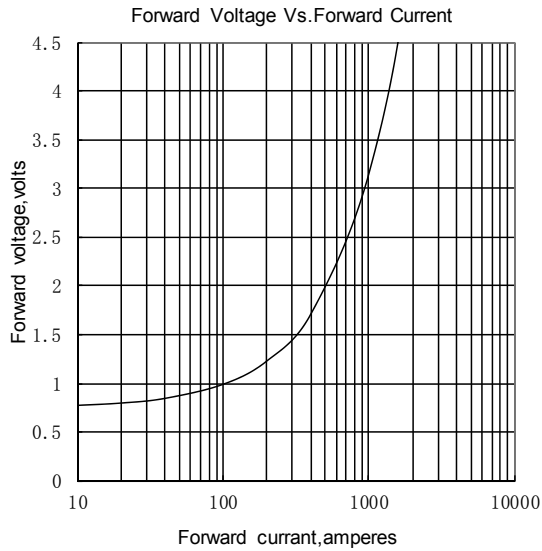

Fig.1

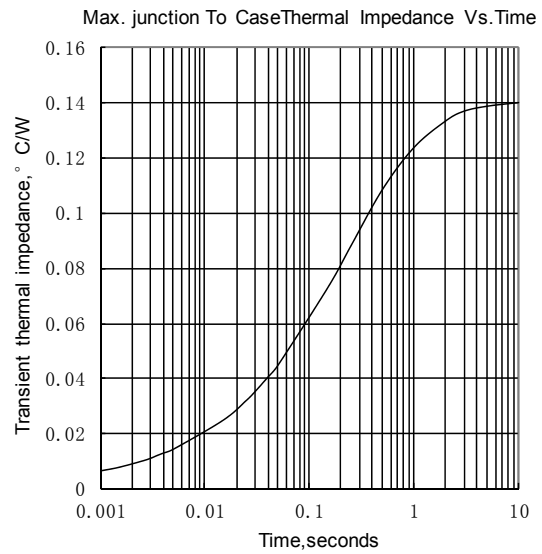

Fig.2

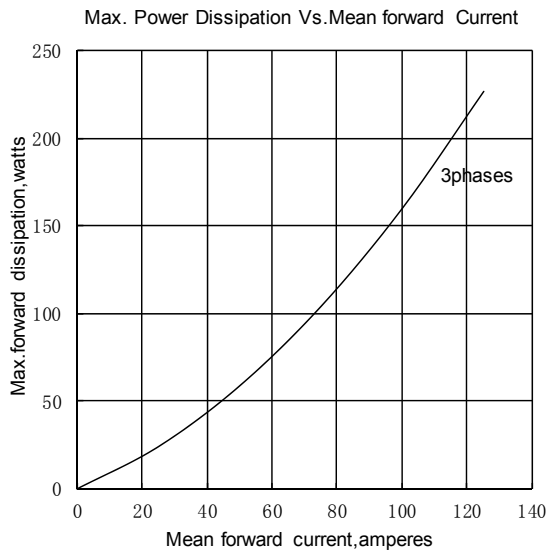

Fig.3

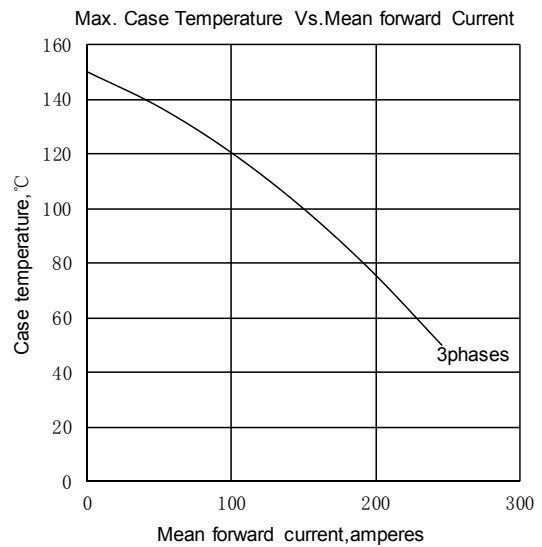

Fig.4

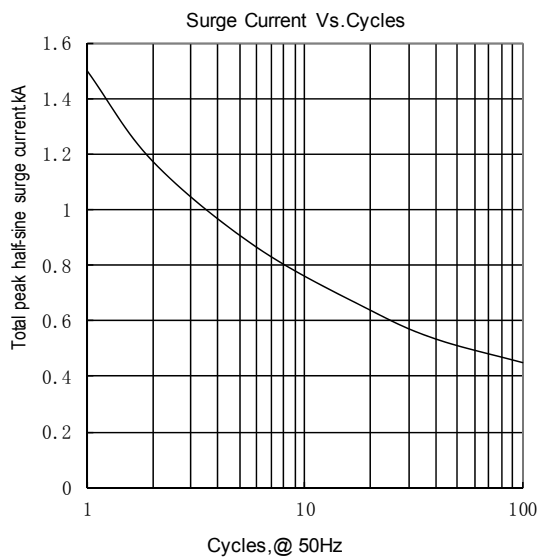

Fig.5

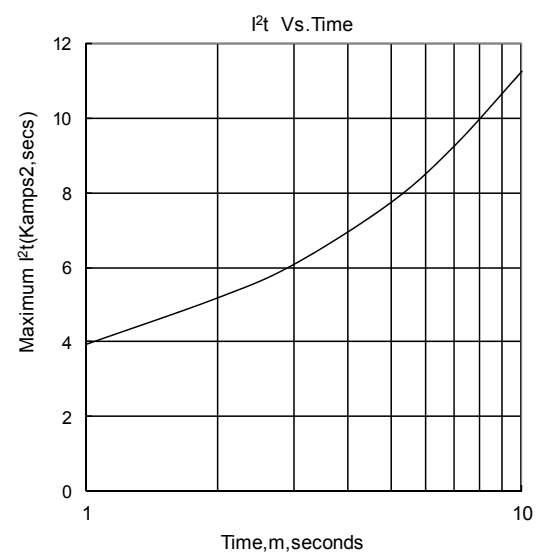
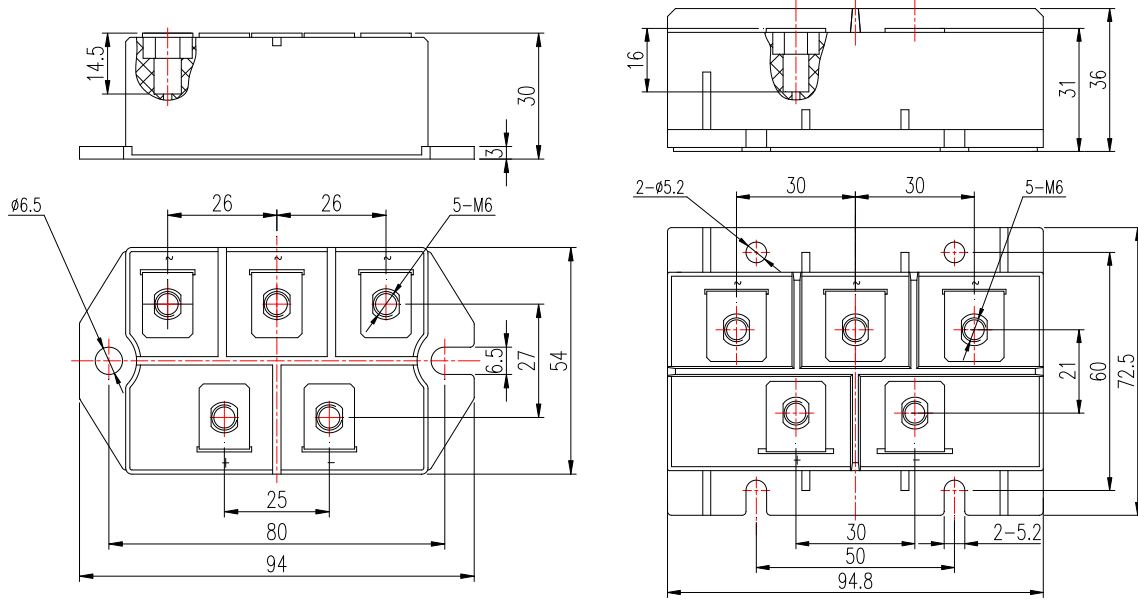

Fig.6

Outline:



234H5

411H5

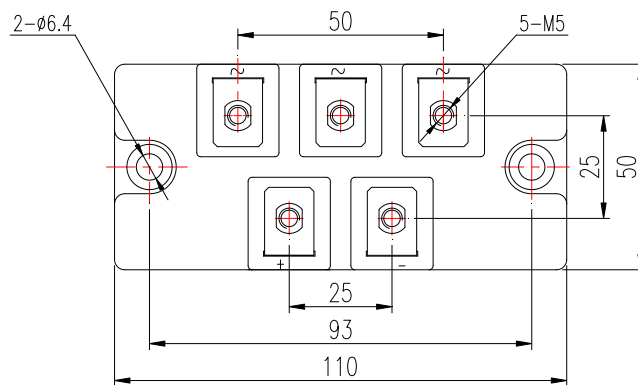
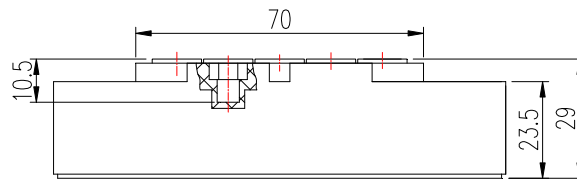

221H5

