

1. General Description

This EPROM-Based 8-bit micro-controller uses a fully static CMOS technology process to achieve higher speed and smaller size with the low power consumption and high noise immunity. On chip memory includes 4K words of ROM, and 192 bytes of static RAM.

2. Features

The followings are some of the features on the hardware and software :

- ◆ Fully CMOS static design
- ◆ 8-bit data bus
- ◆ On chip EPROM size: 4.0 K words
- ◆ Internal RAM size: 192 bytes
- ◆ 37 single word instructions
- ◆ 14-bit instructions
- ◆ 8-level stacks
- ◆ Operating voltage: 2.5 V ~ 5.5 V (PRD Disable)
4.5 V ~ 5.5 V (PRD Enable)
- ◆ Operating frequency: DC ~ 20 MHz
- ◆ The most fast execution time is 200 ns under 20 MHz in all single cycle instructions except the branch instruction
- ◆ Addressing modes include direct, indirect and relative addressing modes
- ◆ Power-on Reset
- ◆ Power edge-detector Reset
- ◆ Power range-detector Reset
- ◆ Sleep Mode for power saving
- ◆ Capture, Compare, PWM module
- ◆ Synchronous serial port with SCM
- ◆ 11 interrupt sources:
 - External INT pin
 - TMR0 timer, TMR1 timer, TMR2 timer
 - A/D conversion completion
 - Port B<7:4> interrupt on change
- ◆ -CCP1, CCP2, SCM, USAR, USAT
- ◆ A/D converter module:
 - 5 analog inputs multiplexed into one A/D converter
 - 8 bit resolution
- ◆ TMR0: 8-bit timer/counter
TMR1: 16-bit timer/counter
TMR2: 8-bit timer
- ◆ 4 types of oscillator can be selected by programming option:
 - RC – Low cost RC oscillator
 - LFXT – Low frequency crystal oscillator
 - XTAL – Standard crystal oscillator
 - HFXT – High frequency crystal oscillator
- ◆ On-chip RC oscillator based Watchdog Timer (WDT)
- ◆ 22 I/O pins with their own independent direction control

3. Applications

The application areas of this MDT10P73 range from appliance motor control and high speed auto-motive to low power remote transmitters/receivers, pointing devices, and telecommunications processors, such as Remote controller, small instruments, chargers, toy, automobile and PC peripheral ... etc.

4. Pin Assignment

/MCLR	1	28	PB7
PA0/AIC0	2	27	PB6
PA1/AIC1	3	26	PB5
PA2/AIC2	4	25	PB4
PA3/AIC3/Vref	5	24	PB3
PA4/T0CKI	6	23	PB2
PA5/SSB/AIC4	7	22	PB1
VSS	8	21	PB0/INT
OSC1/CLKIN	9	20	VDD
OSC2/CLKOUT	10	19	VSS
PC0/T1OSO/T1CKI	11	18	PC7
PC1/T1OSI/CCP2	12	17	PC6
PC2/CCP1	13	16	PC5/SDO
PC3/SCK	14	15	PC4/SDI

MDT10P73K11(SKINNY)

MDT10P73S11(SOP)

MDT10P73SS11(SSOP)

5. Order Information

Device	ROM (Words)	RAM (Bytes)	I/O	A/D (8 bits)	Timer (8/16)	CCP	SCM/USART	Package
MDT10P73K11	4K	192	22	5-channel	2/1	2	YES/YES	SKINNY
MDT10P73S11	4K	192	22	5-channel	2/1	2	YES/YES	SOP
MDT10P73SS11	4K	192	22	5-channel	2/1	2	YES/YES	SSOP

6. Pin Function Description

Pin Name	I/O	Function Description
PA0~PA3, PA5	I/O	Port A, TTL input level / Analog input channel
PA4	I/O	PA4, Schmitt Trigger input levels, Open drain output
PB0~PB7	I/O	Port B, TTL input level / PB0: External interrupt input PB4~PB7: Interrupt on pin change
PC0~PC7	I/O	Port C, Schmitt Trigger input levels
/MCLR	I	Master Clear, Schmitt Trigger input levels
OSC1/CLKIN	I	Oscillator Input / external clock input
OSC2/CLKOUT	O	Oscillator Output / in RC mode, the CLKOUT pin has 1/4 frequency of CLKIN
VDD		Power supply
VSS		Ground

7. Memory Map

(A) Register Map

Address	Description
BANK0	
00	Indirect Addressing Register
01	RTCC
02	PCL
03	STATUS
04	MSR
05	Port A
06	Port B
07	Port C
0A	PCHLAT
0B	INTS
0C	PIFB1
0D	PIFB2
0E	TMR1L
0F	TMR1H
10	T1STA
11	TMR2
12	T2STA
13	SCMBUF
14	SCMCTL
15	CCP1L
16	CCP1H
17	CCP1CTL
18	RCSC
19	TXREG
1A	RCREG
1B	CCP2L
1C	CCP2H
1D	CCP2CTL
1E	ADRES

This specification are subject to be changed without notice. Any latest information

Address	Description
1F	ADS0
20~7F	General purpose register
BANK1	
01	TMR
05	CPIO A
06	CPIO B
07	CPIO C
0C	PIEB1
0D	PIEB2
0E	PSTA
12	T2PER
14	SCMSTA
18	TXSC
19	BRREG
1F	ADS1
A0~FF	General purpose register

(1) IAR (Indirect Address Register): R00

(2) RTCC (Real Time Counter/Counter Register): R01

(3) PC (Program Counter): R02, R0A

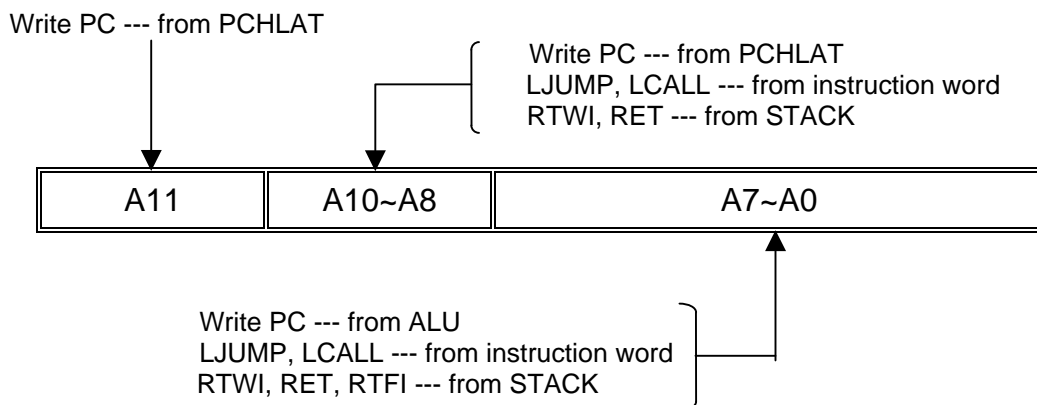

(4) STATUS (Status register): R03

Bit	Symbol	Function
0	C	Carry bit
1	HC	Half Carry bit
2	Z	Zero bit
3	/PF	Power down bit
4	/TF	WDT timer overflow bit
5	RBS0	Register Bank select bit 0: 00h~7Fh (Bank0) 1: 80h~FFh (Bank1)
7~6	--	General purpose bit

(5) MSR (Memory Bank Select Register): R04

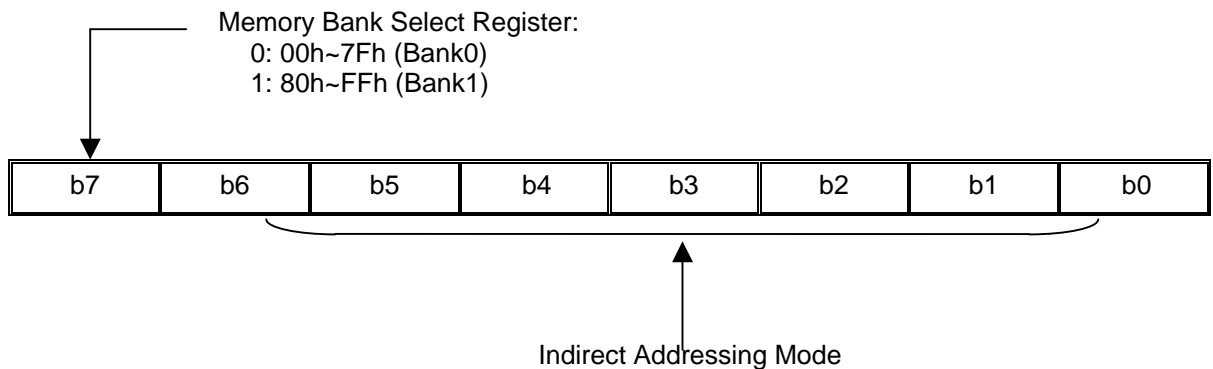

(6) PORT A: R05
PA5~PA0, I/O Register

(7) PORT B: R06
PB7~PB0, I/O Register

(8) PORT C: R07
PC7~PC0, I/O Register

(9) PCHLAT: R0A

(10) INTS (Interrupt Status Register): R0B

Bit	Symbol	Function
0	RBIF	PORT B change interrupt flag, Set when PB <7:4> inputs change
1	INTF	Set when INT interrupt occurs
2	TIF	Set when TMR0 overflows
3	RBIE	0: Disable PB change interrupt 1: Enable PB change interrupt
4	INTS	0: Disable INT interrupt 1: Enable INT interrupt

This specification are subject to be changed without notice. Any latest information

Bit	Symbol	Function
5	TIS	0: Disable TMR0 interrupt 1: Enable TMR0 interrupt
6	PEIE	0: Disable all peripheral interrupt 1: Enable all peripheral interrupt
7	GIS	0: Disable global interrupt 1: Enable global interrupt

(11) PIFB1 (Peripheral Interrupt Flag Bit): R0C

Bit	Symbol	Function
0	TMR1IF	TMR1 interrupt flag 0: TMR1 did not overflow 1: TMR1 overflowed
1	TMR2IF	TMR2 interrupt flag 0: No TMR2 to T2PER match occurred 1: TMR2 to T2PER match occurred
2	CCP1IF	CCP1 interrupt flag 0: No TMR1 capture/compare occurred 1: A TMR1 capture/compare occurred
3	SCMIF	SCM interrupt flag 0: Waiting SCM transmit/receive 1: The SCM transmission/reception is complete
4	TXIF	USART transmit interrupt flag 0: The USART transmit buffer is full 1: The USART transmit buffer is empty
5	RCIF	USART receive interrupt flag 0: The USART receive buffer is empty 1: The USART receive buffer is full
6	ADIF	A/D interrupt flag 0: A/D conversion is not complete 1: A/D conversion completed
7	--	Unimplemented

(12) PIFB2 (Peripheral Interrupt Flag Bit): R0D

Bit	Symbol	Function
0	CCP2IF	CCP2 interrupt flag 0: No TMR1 capture/compare occurred 1: A TMR1 capture/compare occurred
7~1	--	Unimplemented

(13) TMR1L: R0E

The LSB of the 16-bit TMR1

(14) TMR1H: R0F

The MSB of the 16-bit TMR1

(15) T1STA: R10

Bit	Symbol	Function
0	TMR1ON	0: Stop TMR1 1: Enable TMR1
1	TMR1CLK	0: Internal clock ($F_{osc}/4$) 1: External clock from pin PC0
2	/T1SYNC	TMR1CLK = 1 0: Synchronize external clock 1: Do not synchronize external clock TMR1CLK = 0 This bit is ignored
3	T1OSCEN	0: TMR1 Oscillator is shut off 1: TMR1 Oscillator is enable
5~4	T1CKPS1 ~ T1CKPS0	1 1 = 1:8 Prescale value 1 0 = 1:4 Prescale value 0 1 = 1:2 Prescale value 0 0 = 1:1 Prescale value
7~6	--	Unimplemented

(16) TMR2: R11

TMR2 register

(17) T2STA: R12

Bit	Symbol	Function
1~0	T2CKPS1 ~ T2CKPS0	0 0 = Prescaler is 1 0 1 = Prescaler is 4 1 x = Prescaler is 16
2	TMR2ON	0: TMR2 is off 1: TMR2 is on
7~3	--	Unimplemented

(18) SCMBUF: R13

Serial communication port buffer

(19) SCMCTL: R14

Bit	Symbol	Function
3~0	SCM3 ~ SCM0	0 0 0 0: SCM master mode, clock = Fosc/4 0 0 0 1: SCM master mode, clock = Fosc/16 0 0 1 0: SCM master mode, clock = Fosc/64 0 0 1 1: SCM master mode, clock = TMR2 output/2 0 1 0 0: SCM slave mode, clock = SCK pin, /SS control enable 0 1 0 1: SCM slave mode, clock = SCK pin, /SS control disable
4	CKS	0: Transmit happens on rising edge, receive on falling edge, Idle state for clock is low level. 1: Transmit happens on falling edge, receive on rising edge, Idle state for clock is high level
5	SCMEN	0: Disable SCM, then PC3, PC4, PC5 is I/O port. 1: Enable SCM
6	SCMROI	0: No overflow 1: Overflow
7	WCOL	0: No collision 1: The SCMBUF is written while it is still transmitting the previous word

(20) CCP1L: R15

Capture/Compare/PWM LSB

(21) CCP1H: R16
Capture/Compare/PWM MSB

(22) CCP1CTL: R17

Bit	Symbol	Function
3~0	CCP1M3 ~ CCP1M0	0 0 0 0: CCP1 off 0 1 0 0: Capture1 mode, every falling edge 0 1 0 1: Capture1 mode, every rising edge 0 1 1 0: Capture1 mode, every 4 th rising edge 0 1 1 1: Capture1 mode, every 16 th rising edge 1 0 0 0: Compare1 mode, set output on match 1 0 0 1: Compare1 mode, clear output on match 1 0 1 0: Compare1 mode, generate software interrupt on match 1 0 1 1: Compare1 mode, trigger special event 1 1 x x: PWM1 mode
5~4	PWM1LSB	These bits are the two LSBs of the PWM1 duty cycle
7~6	--	Unimplemented

(23) RCSC: R18

Bit	Symbol	Function
0	RX9DF	9 th bit of received data
1	OERF	0: No overrun error 1: Overrun error
2	FERF	0: No framing error 1: Framing error
3	--	Unimplemented
4	CRENF	0: Disable continuous receive 1: Enable continuous receive
5	SRENF	0: Disable single receive 1: Enable single receive
6	RX9ENF	0: Select 8-bit reception 1: Select 9-bit reception
7	SPENF	0: Serial port disable 1: Serial port enable

(24) TXREG: R19
 USART transmit register

(25) RCREG: R1A
 USART receive register

(26) CCP2L: R1B
 Capture/Compare/PWM LSB

(27) CCP2H: R1C
 Capture/Compare/PWM MSB

(28) CCP2CTL: R1D

Bit	Symbol	Function
3~0	CCP2M3	0 0 0 0: CCP2 off
	~	0 1 0 0: Capture2 mode, every falling edge
	CCP2M0	0 1 0 1: Capture2 mode, every rising edge
		0 1 1 0: Capture2 mode, every 4 th rising edge
		0 1 1 1: Capture2 mode, every 16 th rising edge
		1 0 0 0: Compare2 mode, set output on match
		1 0 0 1: Compare2 mode, clear output on match
		1 0 1 0: Compare2 mode, generate software interrupt on match
		1 0 1 1: Compare2 mode, trigger special event
1 1 x x: PWM2 mode		
5~4	PWM2LSB	These bits are the two LSBs of the PWM2 duty cycle
7~6	--	Unimplemented

(29) ADRES: R1E
 A/D result register high byte. The ADRES register is not a writable register.

(30) ADS0 (A/D Status Register): R1F

Bit	Symbol	Function
0	ADRUN	0: A/D converter module is shut off and consumes no operating current 1: A/D converter module is operating
1	--	Unimplemented
2	GO/DONEB	0: A/D conversion not in progress 1: A/D conversion in progress
5~3	CHS2~0	000: AIC0 001: AIC1 010: AIC2 011: AIC3 100: AIC4
7~6	ASCS1-0	00: fosc/2 01: fosc/8 10: fosc/32 11: f RC (*Note)

*Note: determined by OSC mode, HF: fosc/32, XT: fosc/8, RC: fosc/2, LF: fosc/2

(31) TMR (Time Mode Register): R81

Bit	Symbol	Function		
		Prescaler Value	RTCC rate	WDT rate
2~0	PS2~0	0 0 0	1 : 2	1 : 1
		0 0 1	1 : 4	1 : 2
		0 1 0	1 : 8	1 : 4
		0 1 1	1 : 16	1 : 8
		1 0 0	1 : 32	1 : 16
		1 0 1	1 : 64	1 : 32
		1 1 0	1 : 128	1 : 64
		1 1 1	1 : 256	1 : 128
3	PSC	Prescaler assignment bit 0: RTCC 1: Watchdog Timer		
4	TCE	RTCC signal edge 0: Increment on low-to-high transition on RTCC pin 1: Increment on high-to-low transition on RTCC pin		
5	TCS	RTCC signal set 0: Internal instruction cycle clock 1: Transition on RTCC pin		
6	IES	Interrupt edge select 0: Interrupt on falling edge on PB0 1: Interrupt on rising edge on PB0		
7	PBPH	PORTB7~0 pull-hi 0: PORTB7~0 pull-hi are enable 1: PORTB7~0 pull-hi are disable		

(32) CPIO A (Control Port I/O Mode Register): R85

=“0”, I/O pin in output mode;

=“1”, I/O pin in input mode.

(33) CPIO B (Control Port I/O Mode Register): R86
 = "0", I/O pin in output mode;
 = "1", I/O pin in input mode.

(34) CPIO C (Control Port I/O Mode Register): R87
 = "0", I/O pin in output mode;
 = "1", I/O pin in input mode.

(35) PIEB1: R8C

Bit	Symbol	Function
0	TMR1IE	TMR1 interrupt enable bit 0: Disable TMR1 interrupt 1: Enable TMR1 interrupt
1	TMR2IE	TMR2 interrupt enable bit 0: Disable TMR2 interrupt 1: Enable TMR2 interrupt
2	CCP1IE	CCP1 interrupt enable bit 0: Disable CCP1 interrupt 1: Enable CCP1 interrupt
3	SCMIE	SCM interrupt enable bit 0: Disable SCM interrupt 1: Enable SCM interrupt
4	TXIE	USART transmit interrupt enable bit 0: Disable the USART transmit interrupt 1: Enable the USART transmit interrupt
5	RCIE	USART receive interrupt enable bit 0: Disable the USART receive interrupt 1: Enable the USART receive interrupt
6	ADIE	A/D interrupt enable bit 0: Disable A/D interrupt 1: Enable A/D interrupt
7	--	Unimplemented

(36) PIEB2: R8D

Bit	Symbol	Function
0	CCP2IE	0: Disable CCP2 interrupt 1: Enable CCP2 interrupt
7~1	--	Unimplemented

(37) PSTA: R8E

Bit	Symbol	Function
0	PRDB	0: Power range-detector Reset occurred 1: No Power range-detector Reset Occurred
1	PORB	0: Power on Reset occurred 1: No Power on Reset occurred
7~2	--	Unimplemented

(38) T2PER: R92
Timer2 period

(39) SCMSTA: R94

Bit	Symbol	Function
0	BF	0: Receive not complete 1: Receive complete
7~1	--	Unimplemented

(40) TXSC: R98

Bit	Symbol	Function
0	TX9DF	9 th bit of transmit data
1	TSRCF	0: TSR full 1: TSR empty
2	HBRCF	0: Low speed 1: High speed
3	--	Unimplemented
4	UMSF	0: USART asynchronous mode 1: USART synchronous mode
5	TXENF	0: Transmit disable 1: Transmit enable
6	TX9ENF	0: Select 8-bit reception 1: Select 9-bit reception
Bit	Symbol	Function
7	CSSF	0: Slave mode 1: Master mode

(41) BRREG: R99
Baud rate register

(42) ADS1 (A/D Status Register): R9F

Bit	Symbol	Function
2~0	PAVM2~0	0 0 0: PA0~3,PA5 = analog input. VREF = VDD 0 0 1: PA0~2,PA5 = analog input. PA3 = ref input, VREF = PA3 0 1 0: PA0~3,PA5 = analog input. VREF = VDD 0 1 1: PA0~2,PA5 = analog input. PA3 = ref input, VREF = PA3 1 0 0: PA0, 1, 3 = analog input. PA2, 5 = digital I/O, VREF = VDD 1 0 1: PA0, 1 = analog input. PA2, 5 = digital I/O, VREF = PA3 1 1 x: PA0~3, 5 = digital I/O
7~3	--	Unimplemented

(43) Configurable options for EPROM (Set by writer)

Oscillator Type
RC Oscillator
HFXT Oscillator
XTAL Oscillator
LFXT Oscillator

Watchdog Timer control
Watchdog timer disable all the time
Watchdog timer enable all the time

Power-range control
Power-range disable
Power-range enable

Oscillator-start Timer control
0ms
75ms

Power-edge Detect
PED Disable
PED Enable

Security state
Security Disable
Security Enable

(B) Program Memory

Address	Description
000-FFF	Program memory
000	The starting address of power on, external reset or WDT time-out reset.
004	Interrupt vector

8. Reset Condition for all Registers

Register	Address	Power-On Reset, Power range detector Reset	/MCLR or WDT Reset	Wake-up from SLEEP
IAR	00h	N/A	N/A	N/A
RTCC	01h	xxxx xxxx	uuuu uuuu	uuuu uuuu
PC	0Ah,02h	0000 0000 0000	0000 0000 0000	PC+1
STATUS	03h	0001 1xxx	000# #uuu	000# #uuu
MSR	04h	xxxx xxxx	uuuu uuuu	uuuu uuuu
PORT A	05h	--xx xxxx	--uu uuuu	--uu uuuu
PORT B	06h	xxxx xxxx	uuuu uuuu	uuuu uuuu
PORT C	07h	xxxx xxxx	uuuu uuuu	uuuu uuuu
PCHLAT	0Ah	---0 0000	---0 0000	---u uuuu
INTS	0Bh	0000 000x	0000 000u	uuuu uuuu
PIFB1	0Ch	-000 0000	-000 0000	-uuu uuuu
PIFB2	0Dh	---- ---0	---- ---0	---- ---u
TMR1L	0Eh	xxxx xxxx	uuuu uuuu	uuuu uuuu
TMR1H	0Fh	xxxx xxxx	uuuu uuuu	uuuu uuuu
T1STA	10h	--00 0000	--uu uuuu	--uu uuuu
TMR2	11h	0000 0000	0000 0000	uuuu uuuu
T2STA	12h	---- -000	---- -uuu	---- -uuu
SCMBUF	13h	xxxx xxxx	uuuu uuuu	uuuu uuuu
SCMCTL	14h	0000 0000	0000 0000	uuuu uuuu
CCP1L	15h	xxxx xxxx	uuuu uuuu	uuuu uuuu

This specification are subject to be changed without notice. Any latest information

Register	Address	Power-On Reset, Power range detector Reset	/MCLR or WDT Reset	Wake-up from SLEEP
CCP1H	16h	xxxx xxxx	uuuu uuuu	uuuu uuuu
CCP1CTL	17h	--00 0000	--00 0000	--uu uuuu
RCSC	18h	0000 -00x	0000 -00x	uuuu -uuu
TXREG	19h	0000 0000	0000 0000	uuuu uuuu
RCREG	1Ah	0000 0000	0000 0000	uuuu uuuu
CCP2L	1Bh	xxxx xxxx	uuuu uuuu	uuuu uuuu
CCP2H	1Ch	xxxx xxxx	uuuu uuuu	uuuu uuuu
CCP2CTL	1Dh	--00 0000	--00 0000	--uu uuuu
ADRES	1Eh	xxxx xxxx	uuuu uuuu	uuuu uuuu
ADS0	1Fh	0000 00-0	0000 00-0	uuuu uu-u
TMR	81h	1111 1111	1111 1111	uuuu uuuu
CPIOA	85h	--11 1111	--11 1111	--uu uuuu
CPIOB	86h	1111 1111	1111 1111	uuuu uuuu
CPIOC	87h	1111 1111	1111 1111	uuuu uuuu
PIEB1	8Ch	-000 0000	-000 0000	-uuu uuuu
PSTA	8Eh	---- --0u	---- --uu	---- --uu
T2PER	92h	1111 1111	1111 1111	1111 1111
SCMSTA	94h	---- ---0	---- ---0	---- ---u
TXSC	98h	0000 -010	0000 -010	uuuu -uuu
BRREG	99h	0000 0000	0000 0000	uuuu uuuu
ADS1	9Fh	---- -000	---- -000	---- -uuu

Note : u=unchanged, x=unknown, - =unimplemented, read as "0"

= value depends on the condition of the following table

Condition	Status: bit 4	Status: bit 3	PSTA: bit 1	PSTA: bit 0
/MCLR reset (not during SLEEP)	u	u	u	u
/MCLR reset during SLEEP	1	0	u	u
WDT reset (not during SLEEP)	0	1	u	u
WDT reset during SLEEP	0	0	u	u
Power-on reset	1	1	0	x
Power-range reset	1	1	u	0

Note : u=unchanged, x=unknown, - =unimplemented, read as "0"

This specification are subject to be changed without notice. Any latest information

9. Instruction Set

Instruction Code	Mnemonic Operands	Function	Operating	Status
010000 00000000	NOP	No operation	None	
010000 00000001	CLRWT	Clear Watchdog timer	0→WT	TF, PF
010000 00000010	SLEEP	Sleep mode	0→WT, stop OSC	TF, PF
010000 00000011	TMODE	Load W to TMODE register	W→TMODE	None
010000 00000100	RET	Return from subroutine	Stack→PC	None
010000 00000rrr	CPIO R	Control I/O port register	W→CPIO R	None
010001 1rrrrrrr	STWR R	Store W to register	W→R	None
011000 trrrrrrr	LDR R, t	Load register	R→t	Z
111010 iiiiiii	LDWI i	Load immediate to W	i→W	None
010111 trrrrrrr	SWAPR R, t	Swap halves register	[R(0~3) ↔ R(4~7)] →t	None
011001 trrrrrrr	INCR R, t	Increment register	R + 1→t	Z
011010 trrrrrrr	INCRSZ R, t	Increment register, skip if zero	R + 1→t	None
011011 trrrrrrr	ADDWR R, t	Add W and register	W + R→t	C, HC, Z
011100 trrrrrrr	SUBWR R, t	Subtract W from register	R - W→t or (R+/W+1→t)	C, HC, Z
011101 trrrrrrr	DECR R, t	Decrement register	R - 1→t	Z
011110 trrrrrrr	DECRSZ R, t	Decrement register, skip if zero	R - 1→t	None
010010 trrrrrrr	ANDWR R, t	AND W and register	R ∩ W→t	Z
110100 iiiiiii	ANDWI i	AND W and immediate	i ∩ W→W	Z
010011 trrrrrrr	IORWR R, t	Inclu. OR W and register	R ∪ W→t	Z
110101 iiiiiii	IORWI i	Inclu. OR W and immediate	i ∪ W→W	Z
010100 trrrrrrr	XORWR R, t	Exclu. OR W and register	R ⊕ W→t	Z
110110 iiiiiii	XORWI i	Exclu. OR W and immediate	i ⊕ W→W	Z
011111 trrrrrrr	COMR R, t	Complement register	/R→t	Z
010110 trrrrrrr	RRR R, t	Rotate right register	R(n) →R(n-1), C→R(7), R(0)→C	C
010101 trrrrrrr	RLR R, t	Rotate left register	R(n)→r(n+1), C→R(0), R(7)→C	C
010000 1xxxxxxx	CLRW	Clear working register	0→W	Z
010001 0rrrrrrr	CLRR R	Clear register	0→R	Z
0000bb brrrrrrr	BCR R, b	Bit clear	0→R(b)	None
0010bb brrrrrrr	BSR R, b	Bit set	1→R(b)	None
0001bb brrrrrrr	BTSC R, b	Bit Test, skip if clear	Skip if R(b)=0	None
0011bb brrrrrrr	BTSS R, b	Bit Test, skip if set	Skip if R(b)=1	None

This specification are subject to be changed without notice. Any latest information

Instruction Code	Mnemonic Operands	Function	Operating	Status
100nnn nnnnnnnn	LCALL n	Long CALL subroutine	n→PC, PC+1→Stack	None
101nnn nnnnnnnn	LJUMP n	Long JUMP to address	n→PC	None
110111 iiiiii	ADDWI i	Add immediate to W	W+i→W	C,HC,Z
110001 iiiiii	RTWI i	Return, place immediate to W	Stack→PC,i→W	None
111000 iiiiii	SUBWI i	Subtract W from immediate	i-W→W	C,HC,Z
010000 00001001	RTFI	Return from interrupt	Stack→PC,1→GIS	None

Note :

W	:	Working register	b	:	Bit position
WT	:	Watchdog timer	t	:	Target
TMODE	:	TMODE mode register	0	:	Working register
CPIO	:	Control I/O port register	1	:	General register
TF	:	Timer overflow flag	R	:	General register address
PF	:	Power loss flag	C	:	Carry flag
PC	:	Program Counter	HC	:	Half carry
OSC	:	Oscillator	Z	:	Zero flag
Inclu.	:	Inclusive 'U'	/	:	Complement
Exclu.	:	Exclusive '⊕'	x	:	Don't care
AND	:	Logic AND '∩'	i	:	Immediate data (8 bits)
			n	:	Immediate address

10. Electrical Characteristics

*Note: Temperature=25°C

1. Operation Current:

(1) HF (C=10p), WDT – disable, PRD – disable

	4M	10M	20M	Sleep
2.5V	480uA	1mA	2.1mA	1uA
3.0V	600uA	1.3mA	2.5mA	1uA
4.0V	1mA	2mA	4mA	1uA
5.0V	1.5mA	2.9mA	5.3mA	1uA
5.5V	1.8mA	4mA	6.8mA	1uA

These parameters are for reference only.

(2) XT (C=10p), WDT – disable, PRD – disable

	1M	4M	10M	Sleep
2.5V	130uA	440uA	1mA	1uA
3.0V	160uA	560uA	1.2mA	1uA
4.0V	400uA	900uA	2mA	1uA
5.0V	700uA	1.3mA	2.8mA	1uA
5.5V	940uA	1.6mA	3.3mA	1uA

These parameters are for reference only.

This specification are subject to be changed without notice. Any latest information

(3) LF (C=10p), WDT – disable, PRD – disable

	32K	455K	1M	Sleep
2.5V	30uA	80uA	170uA	1uA
3.0V	40uA	120uA	210uA	1uA
4.0V	90uA	210uA	420uA	1uA
5.0V	180uA	450uA	600uA	1uA
5.5V	270uA	600uA	900uA	1uA

These parameters are for reference only.

(4) RC, WDT – disable, PRD – disable, @VDD = 5.0V

C	R	Freq.	Current
3p	4.7k	11.8M	4mA
	10k	5.8M	2mA
	47k	1.35M	600uA
	100k	644K	400uA
	300k	196K	250uA
	470k	136K	200uA
20p	4.7k	6M	2.7mA
	10k	3.04M	1.5mA
	47k	692K	500uA
	100k	327K	350uA
	300k	98K	250uA
	470k	70K	200uA
100p	4.7k	2.18M	1.7mA
	10k	1.09M	900uA
	47k	240K	300uA
	100k	112K	250uA
	300k	34K	200uA
	470k	25K	200uA
300p	4.7k	963K	1.4mA
	10k	464K	700uA
	47k	101K	250uA
	100k	47K	200uA
	300k	14K	200uA
	470k	10K	200uA

These parameters are for reference only.

(5) RC, WDT – disable, PRD – disable, @VDD = 3.0V

C	R	Freq.	Current
3p	4.7k	11.6M	2mA
	10k	6.52M	1.2mA
	47k	1.62M	300uA
	100k	784K	160uA
	300k	242K	60uA
	470k	173K	60uA
20p	4.7k	6.88M	1.5mA
	10k	3.65M	800uA
	47k	868K	170uA
	100k	415K	100uA
	300k	127K	60uA
	470k	91K	60uA
100p	4.7k	2.94M	1mA
	10k	1.52M	500uA
	47k	348K	120uA
	100k	116K	60uA
	300k	50K	60uA
	470k	36K	60uA
300p	4.7k	1.42M	800uA
	10k	724K	400uA
	47k	164K	100uA
	100k	79K	60uA
	300k	24K	60uA
	470k	17K	60uA

These parameters are for reference only.

2. Input Voltage (VDD = 5V):

	PA~PC	Min	Max
Vil	TTL	VSS	0.8V
	Schmitt trigger	VSS	0.6V
Vih	TTL	3.0V	VDD
	Schmitt trigger	3.8V	VDD

These parameters are for reference only.

Input Voltage (VDD = 3V):

	PA~PC	Min	Max
Vil	TTL	VSS	0.4V
	Schmitt trigger	VSS	0.2V
Vih	TTL	2.0V	VDD
	Schmitt trigger	2.6V	VDD

These parameters are for reference only.

3. Output Voltage (VDD = 5V):

	PA~PC	Condition
Voh	3.3V	Ioh = -20mA
Vol	0.9V	Iol = 20mA
Voh	4.2V	Ioh = -5mA
Vol	0.6V	Iol = 5mA

These parameters are for reference only.

Output Voltage (VDD = 3V):

	PA~PC	Condition
Voh	1.6V	Ioh = -10mA
Vol	0.6V	Iol = 10mA
Voh	2.4V	Ioh = -5mA
Vol	0.5V	Iol = 5mA

These parameters are for reference only.

4. Output Current (Max.) (VDD = 5V):

	Current
Source current	25mA
Sink current	40mA

These parameters are for reference only.

5. The basic WDT time-out cycle time:

	Time
2.5V	25ms
3.0V	23ms
4.0V	20ms
5.0V	18ms
5.5V	17ms

This specification are subject to be changed without notice. Any latest information

These parameters are for reference only.

6. PRD:**(1) PRD reset voltage:**

	Voltage
Vih	4.2V±10%
Vil	3.8V±10%

These parameters are for reference only.

(2) PRD reset current:

	Current
5.0V	120uA
4.0V	100uA

These parameters are for reference only.

7. Pull high resistor:

VDD	5V	3V
PB7~0	50KΩ±20%	100KΩ±20%

These parameters are for reference only.

8. MCLR filter time:

VDD	5V
Time	1000ns±20%

These parameters are for reference only.