



MDU04N027RH

Single N-channel Trench MOSFET 40V 2.7mΩ 70A

FEATURES

- Trench power MOSFET technology
- N-channel, normal level
- 100% Avalanche tested

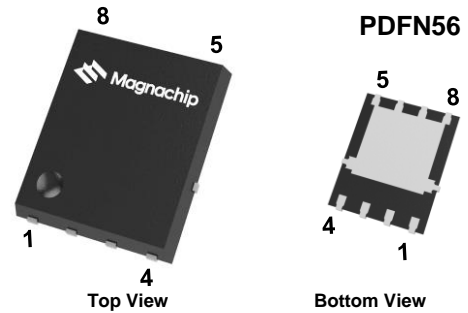

APPLICATIONS

- BLDC Motor Inverter
- Synchronous Rectification
- Power Tool

KEY PERFORMANCE PARAMETERS

V_{DS}	40	V
$R_{DS(on), typ.}$	0.0022	Ω
I_D	70	A
Q_G	78	nC
Junction temperature, $_{max}$	150	$^{\circ}C$

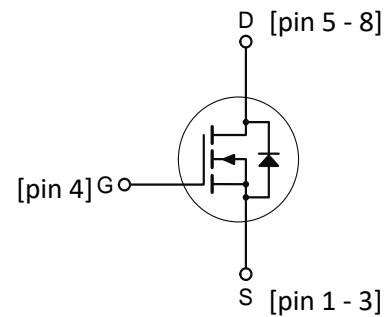

ORDERING INFORMATION

Type / Ordering Code	Package	Marking	Packing	RoHS Status
MDU04N027RH	PDFN56	04N027	Tape & Reel	Halogen Free

<http://www.magnachip.com/>

ABSOLUTE MAXIMUM RATINGS, at $T_c = 25^\circ\text{C}$, unless otherwise specified

PARAMETER		SYMBOL	RATING	UNIT
Drain-source Voltage		V_{DS}	40	V
Gate-source Voltage		V_{GS}	± 20	V
Drain current	$T_c=25^\circ\text{C}$ Silicon Limited	I_D	127	A
	$T_c=25^\circ\text{C}$ Package Limited		70	A
	$T_c=100^\circ\text{C}$ Silicon Limited		80	A
¹⁾ Pulsed drain current	$T_c=25^\circ\text{C}$	I_{DM}	280	A
Total power dissipation	$T_c=25^\circ\text{C}$	P_{tot}	74	W
	$T_c=100^\circ\text{C}$		29	W
²⁾ Avalanche energy, single pulse		E_{AS}	162	mJ
Operating and storage temperature		T_j, T_{stg}	- 55 ~ 150	$^\circ\text{C}$

THERMAL CHARACTERISTICS

PARAMETER		SYMBOL	RATING	UNIT
Thermal resistance, junction - case		$R_{\theta JC}$	1.7	K/W
³⁾ Thermal resistance, junction - ambient		$R_{\theta JA}$	50	K/W

ELECTRICAL CHARACTERISTICS (T_j = 25°C)

STATIC CHARACTERISTICS

PARAMETER	SYMBOL	MIN.	TYP.	MAX.	UNIT	CONDITIONS / NOTE
Drain-source breakdown voltage	V _{(BR)DSS}	40	-	-	V	V _{GS} =0 V, I _D =250 μA
Gate threshold voltage	V _{GS(th)}	1.0	1.8	3.0	V	V _{DS} =V _{GS} , I _D =250 μA
Zero gate voltage drain current	I _{DSS}	-	-	1	μA	V _{DS} =32 V, V _{GS} =0 V
Gate-source leakage current	I _{GSS}	-	-	± 100	nA	V _{GS} =±20 V, V _{DS} =0 V
Drain-source on-state resistance	R _{DS(on)}	-	2.2	2.7	mΩ	V _{GS} =10 V, I _D =27 A
⁴⁾ Gate resistance	R _G	-	1.8	-	Ω	f=1MHz
⁴⁾ Transconductance	g _{fs}	-	60	-	S	V _{DS} =10 V, I _D =27 A

⁴⁾ DYNAMIC CHARACTERISTICS

PARAMETER	SYMBOL	MIN.	TYP.	MAX.	UNIT	CONDITIONS / NOTE
Input capacitance	C _{iss}	-	4360	-	pF	V _{GS} =0 V, V _{DS} =20 V, f=1 MHz
Output capacitance	C _{oss}	-	1140	-	pF	V _{GS} =0 V, V _{DS} =20 V, f=1 MHz
Reverse transfer capacitance	C _{rss}	-	110	-	pF	V _{GS} =0 V, V _{DS} =20 V, f=1 MHz
Turn-on delay time	t _{d(on)}	-	16	-	ns	V _{DD} =20 V, V _{GS} =10 V, I _D =27 A, R _{G,ext} =3Ω
Rise time	t _r	-	14	-	ns	V _{DD} =20 V, V _{GS} =10 V, I _D =27 A, R _{G,ext} =3Ω
Turn-off delay time	t _{d(off)}	-	67	-	ns	V _{DD} =20 V, V _{GS} =10 V, I _D =27 A, R _{G,ext} =3Ω
Fall time	t _f	-	22	-	ns	V _{DD} =20 V, V _{GS} =10 V, I _D =27 A, R _{G,ext} =3Ω

⁴⁾ GATE CHARGE CHARACTERISTICS

PARAMETER	SYMBOL	MIN.	TYP.	MAX.	UNIT	CONDITIONS / NOTE
Gate to source charge	Q _{gs}	-	11	-	nC	V _{DD} =20 V, I _D =27 A, V _{GS} =0 to 10 V
Gate charge at threshold	Q _{gs(th)}	-	8	-	nC	V _{DD} =20 V, I _D =27 A, V _{GS} =0 to 10 V
Gate to drain charge	Q _{gd}	-	15	-	nC	V _{DD} =20 V, I _D =27 A, V _{GS} =0 to 10 V
Switching charge	Q _{sw}	-	18	-	nC	V _{DD} =20 V, I _D =27 A, V _{GS} =0 to 10 V
Gate charge total	Q _g	-	78	-	nC	V _{DD} =20 V, I _D =27 A, V _{GS} =0 to 10 V
Gate plateau voltage	V _{plateau}	-	2.9	-	V	V _{DD} =20 V, I _D =27 A, V _{GS} =0 to 10 V

SOURCE-DRAIN DIODE

PARAMETER	SYMBOL	MIN.	TYP.	MAX.	UNIT	CONDITIONS / NOTE
⁴⁾ Diode continuous forward current	I _S	-	-	70	A	-
⁴⁾ Diode pulse current	I _{S,pulse}	-	-	280	A	pulsed; t _p ≤ 10 μs
Diode forward voltage	V _{SD}	-	1.0	1.2	V	V _{GS} =0 V, I _S =50 A
⁴⁾ Reverse recovery time	t _{rr}	-	47.5	-	ns	I _F =27 A, d _I /dt=100 A/μs
⁴⁾ Reverse recovery charge	Q _{rr}	-	52	-	nC	I _F =27 A, d _I /dt=100 A/μs

Notes

- Pulse width limited by T_{jmax}
- starting T_j = 25°C, L = 1.0mH, I_{AS} = 18A, V_{DD} = 20V, V_{GS} = 10V
- Surface mounted FR-4 board by JEDEC (jesd51-7)
- The parameter is not subject to production testing - guaranteed by design.

ELECTRICAL CHARACTERISTICS DIAGRAMS (25 °C, unless otherwise noted)

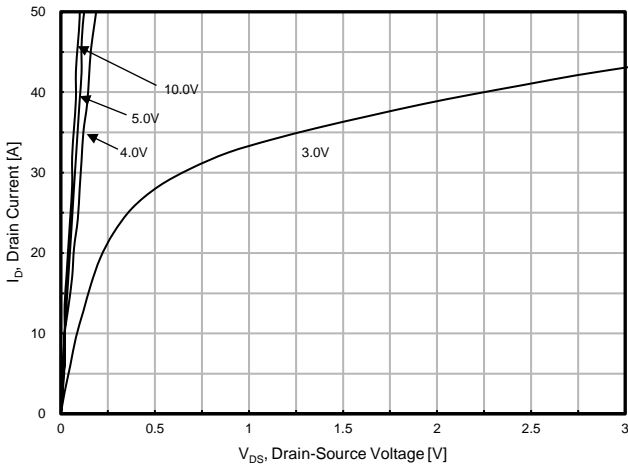

Fig. 1. On-Region Characteristics

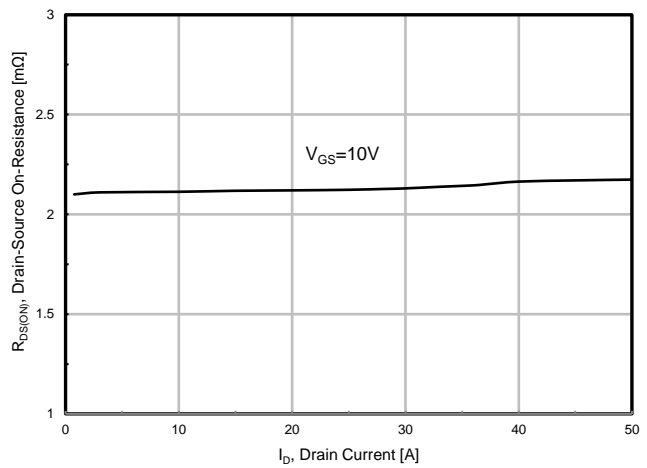

Fig. 2. On-Resistance vs. Drain Current and Gate Voltage

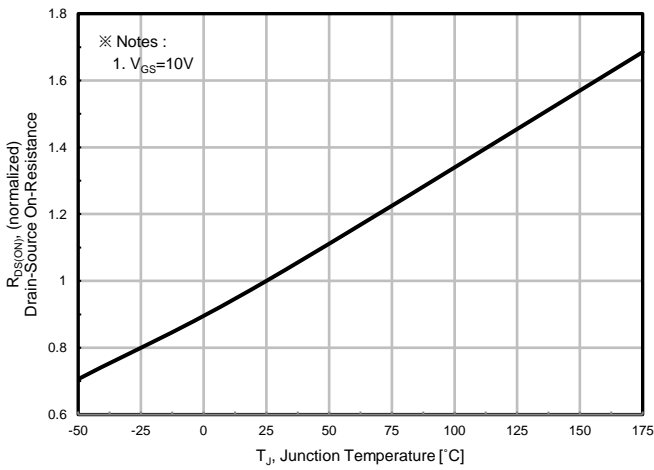

Fig. 3. On-Resistance vs. Junction Temperature

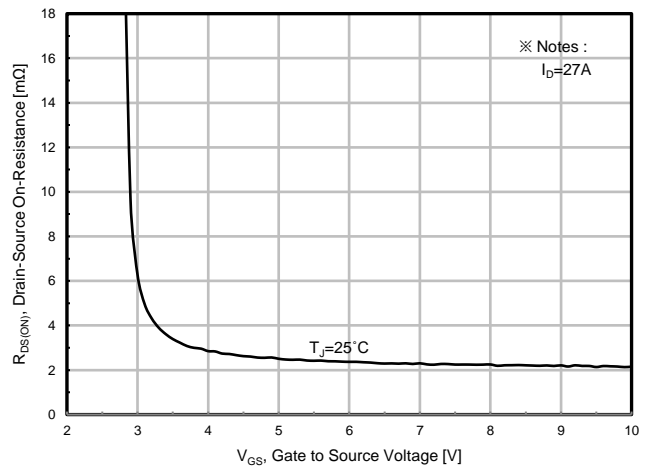

Fig. 4. On-Resistance vs. Gate to Source Voltage

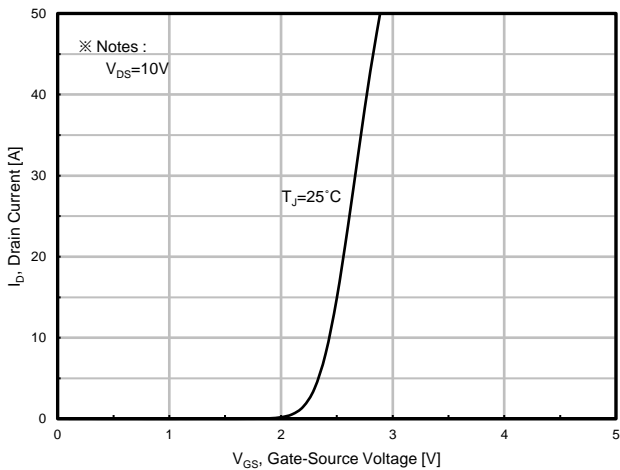

Fig. 5. Transfer Characteristics

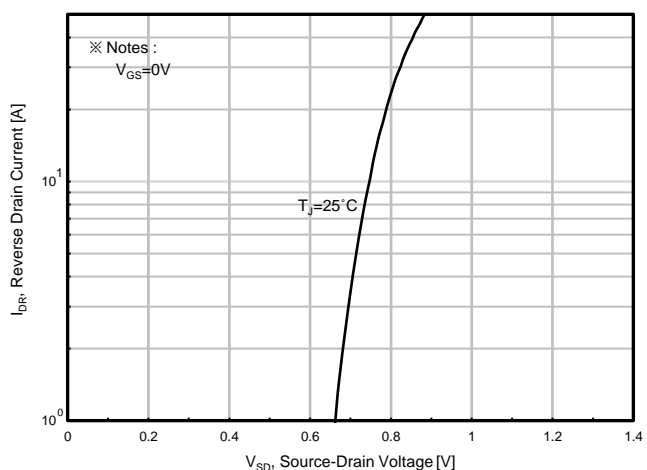

Fig. 6. Source-Drain Diode Forward Voltage

ELECTRICAL CHARACTERISTICS DIAGRAMS (25 °C, unless otherwise noted)

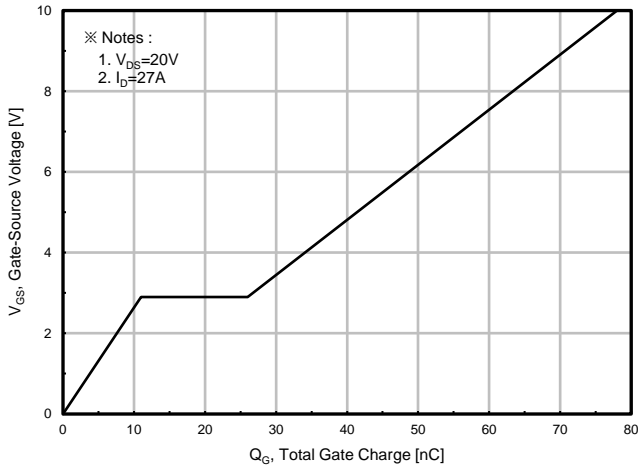

Fig. 7. Gate Charge

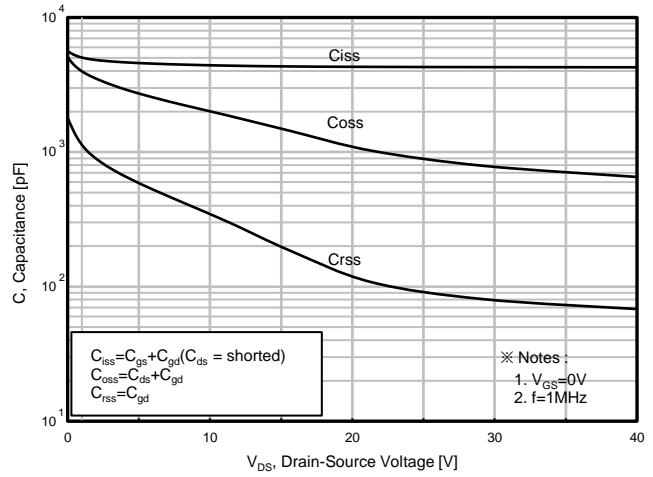

Fig. 8. Capacitance

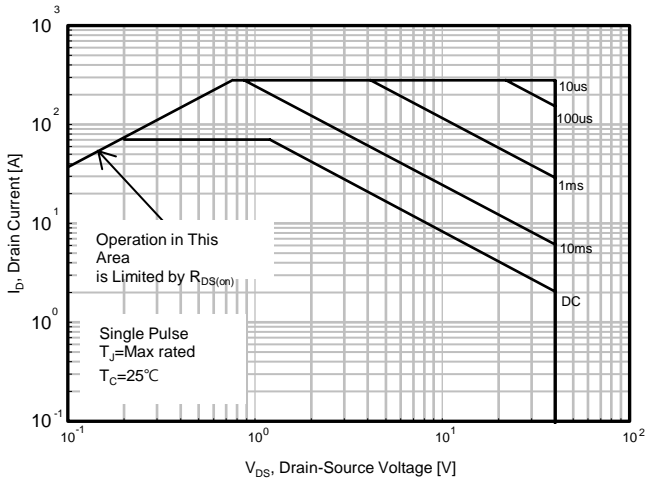

Fig. 9. Safe Operating Area, Junction-to-Ambient

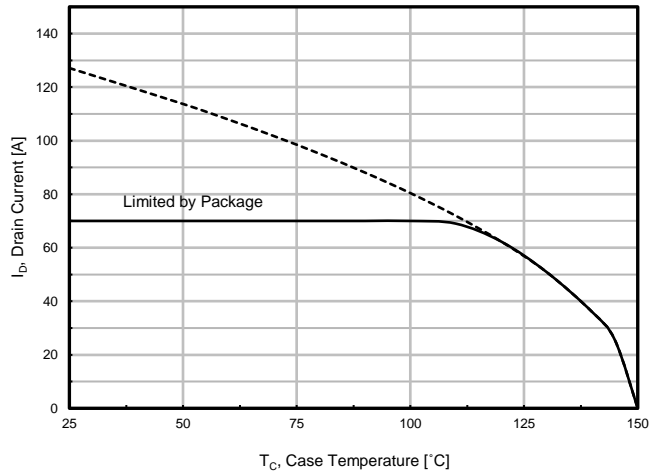

Fig. 10. Maximum Drain vs. Case Temperature

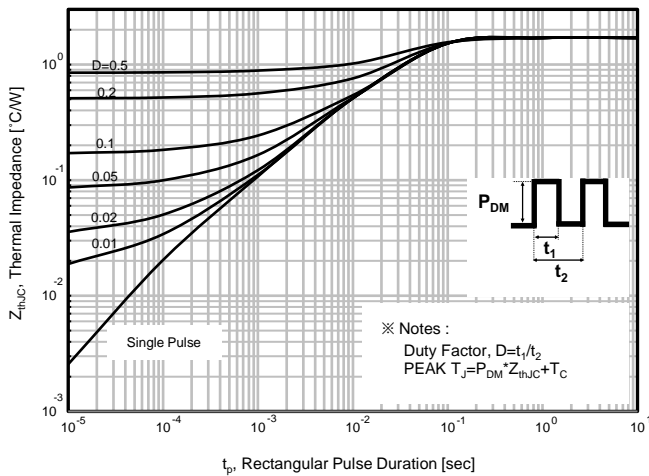
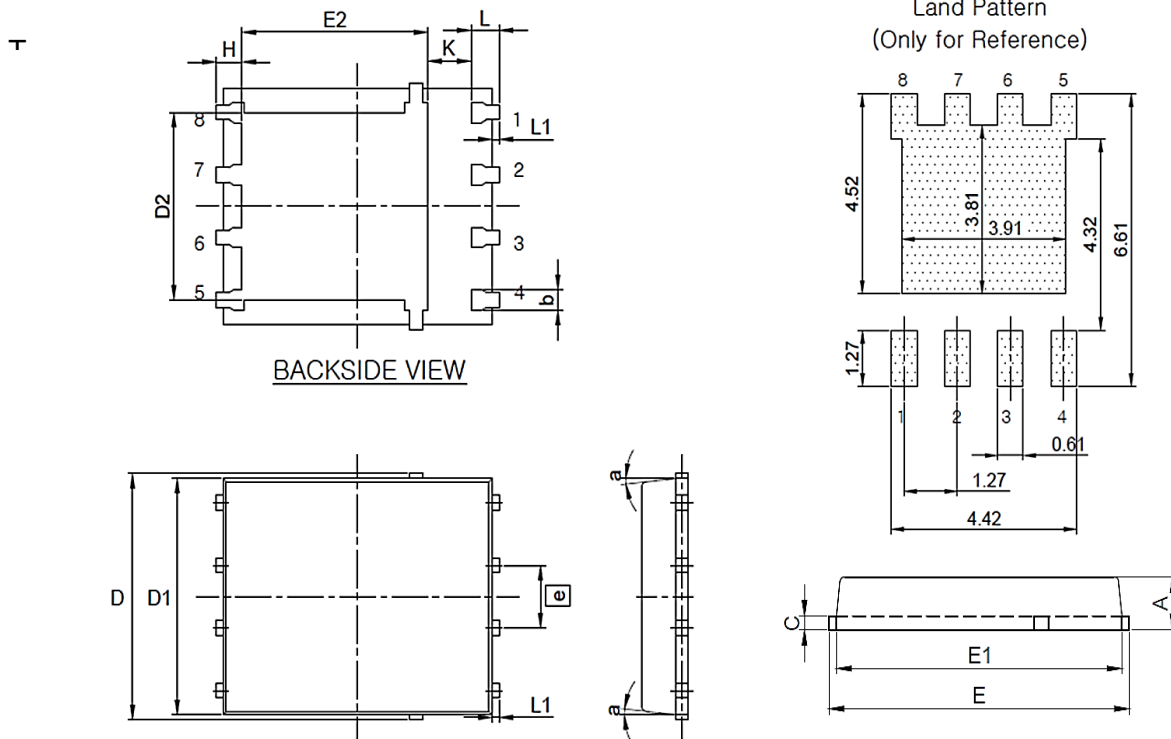

Fig. 11. Thermal Transient Impedance, Junction-to-Case

Package information

PDFN56



Symbol	Dimension (mm)		
	Min.	Norm.	Max.
A	0.90	-	1.10
B	0.33	-	0.51
C	0.20	-	0.34
D	4.50	-	5.30
D1	4.50	-	5.10
D2	3.61	-	4.22
E	5.90	-	6.30
E1	5.50	-	6.10
E2	3.38	-	4.30
e	1.27 BSC		
H	0.41	-	0.71
K	0.20	-	-
L	0.51	-	0.71
L1	0.06	-	0.20
a	0°	-	12°

* Note : Package body size, length and width do not include mold flash, protrusions and gate burs.

DISCLAIMER :

The Products are not designed for use in hostile environments, including, without limitation, aircraft, nuclear power generation, medical appliances, and devices or systems in which malfunction of any Product can reasonably be expected to result in a personal injury. Seller's customers using or selling Seller's products for use in such applications do so at their own risk and agree to fully defend and indemnify Seller.

Magnachip reserves the right to change the specifications and circuitry without notice at any time. Magnachip does not consider responsibility for use of any circuitry other than circuitry entirely included in a Magnachip product.  Magnachip is a registered trademark of Magnachip Semiconductor Ltd.