

ULTRA-SMALL PACKAGE PWM/PFM SWITCHING CONTROL

STEP-UP SWITCHING REGULATOR

Description

The ME2149 series is a CMOS step-up switching regulator which mainly consists of a reference voltage source, an oscillation circuit, an error amplifier, a phase compensation circuit, a PWM/PFM switching control circuit. With an internal low-ON-resistance Nch Power MOS, this product is applicable to applications requiring high efficiency and high output current. The ME2149 series switches its operation to the PFM control circuit whose duty ratio is 15 % with to the PWM/PFM switching control circuit under a light load and to prevent decline in the efficiency by IC operation current.

Feature

- Low voltage operation: Start-up is guaranteed from 0.9 V($I_{OUT} = 1 \text{ mA}$)
- Duty ratio: Built-in PWM/PFM switching control circuit 15 to 78 % .
- oscillator frequency: 1.0MHz
- Output voltage range: 1.5V ~6.5 V
- Output voltage accuracy: $\pm 2\%$
- Soft start function: 2 mS.
- PACKAGE: SOT23-5,SOT89-5,SOP8

Selection Guide

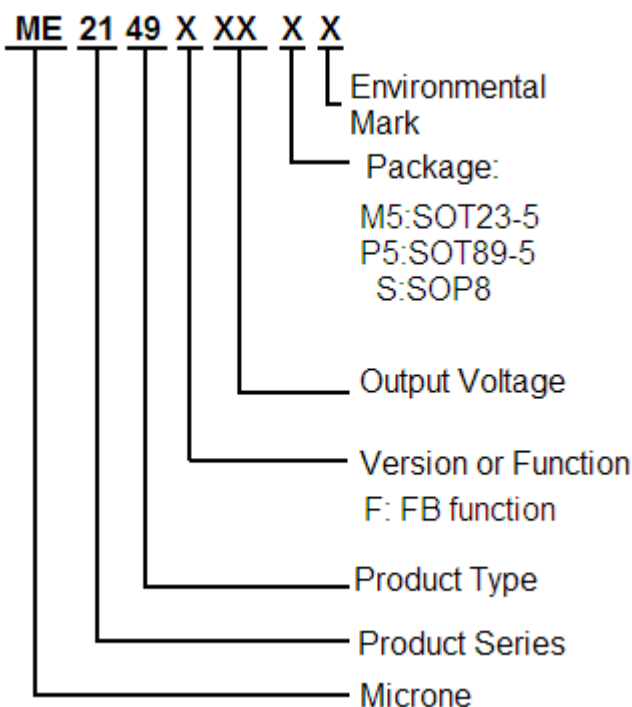

Typical Application

- MP3 players, digital audio players
- Digital cameras, GPS, wireless transceiver
- Portable devices

Pin Configuration

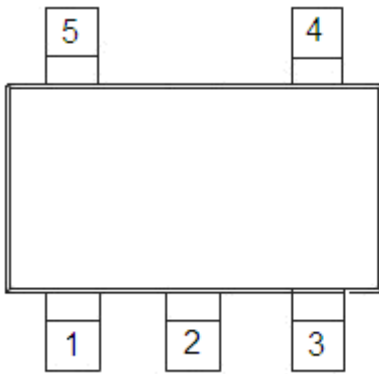

SOT23-5

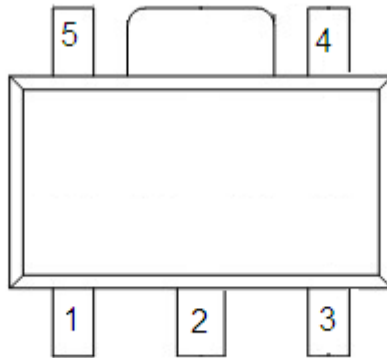

SOT89-5

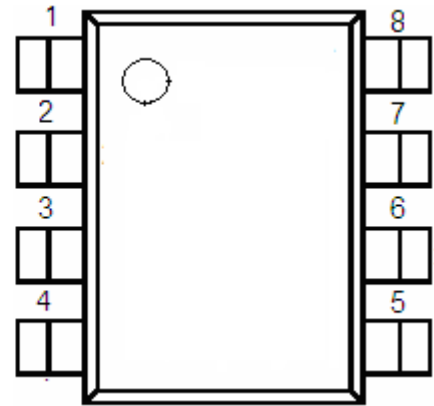

SOP8

Pin information

TYPE	POSFIX	PACKAGE	SWICHING TRANSISTOR	CE FUNCTION	VDD FUNCTION	FB FUNCTION	FEATURE
ME2149F	M5	SOT23-5	Build in Transistor	Yes	Yes	Yes	LX+FB
	P5	SOT89-5					
	SOP8	SOP8					

ME2149F

Pin Number			Pin Name	Function
SOT23-5	SOT89-5	SOP8		
1	3	3	CE	Shutdown pin
2	2	7,8	LX	External transistor connection pin
3	1	2	GND	GND pin
4	5	5,6	VDD	IC power supply pin
5	4	4	FB	Feed Back voltage pin
		1	NC	NC

Block Diagram

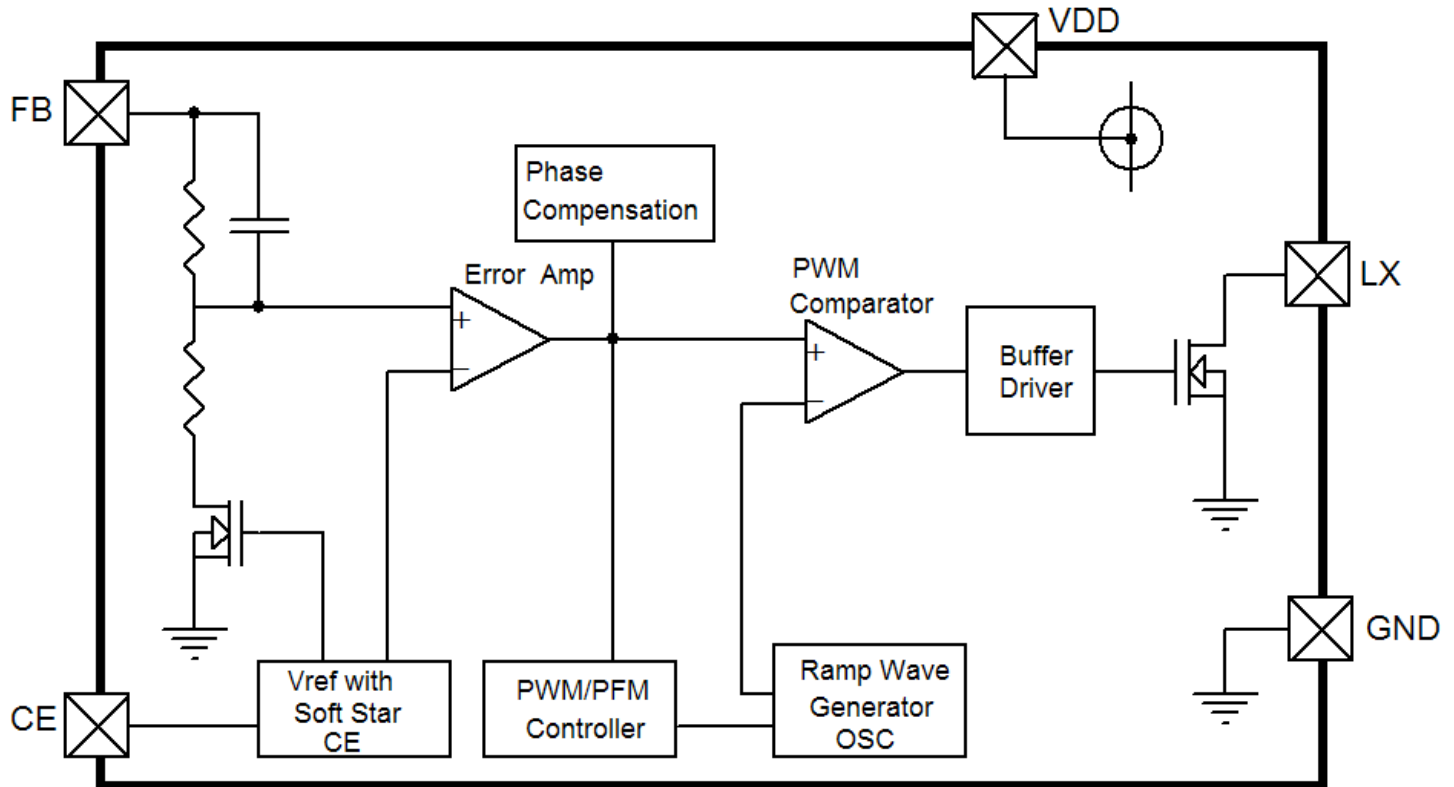

Absolute Maximum Rang

PARAMETER	SYMBOL	RATING	UNIT
VDD Pin Voltage	VDD	-0.3~6.5	V
LX Pin Voltage	LX	-0.3~20	V
CE Pin Voltage	V_{CE}	-0.3~ $V_{in}+0.3$	V
LX Pin Current	I_{LX}	±4000	mA
Power Dissipation	Pd	SOT23-5	300
		SOT89-5	500
		SOP8	800
Operating Temperature Range	T_{Opr}	-25~+85	°C
Storage Temperature Range	T_{stg}	-40~+125	°C

Electrical Characteristics

ME2149F

Measuring conditions: $V_{DD}=V_{CE}=3.3V$, $T_{opt}=25^{\circ}C$ 。 Unless otherwise specified.

Parameter	SYMBOL	CONDITION		MIN	TYP	MAX	UNIT	Circuit
Feedback voltage	V_{FB}	-		1.225	1.25	1.275	V	2
Input voltage	VDD	-		-	-	6	V	2
Operation start voltage	V_{ST1}	$I_{OUT}=1mA$		-	-	0.9	V	2
Oscillation start voltage	V_{ST2}	No external parts, voltage applied to V_{OUT}		-	-	0.7	V	1
Operation holding voltage	V_{HLD}	$I_{OUT}=1mA$, Measured by decreasing V_{IN} voltage gradually		0.7	-	-	V	2
Current consumption 1	I_{SS1}	$V_{FB}=V_{FB(S)} \times 0.95$		-	4.0	-	mA	1
Current consumption 2	I_{SS2}	$V_{FB}=1.5V$		-	25	-	μA	1
Current consumption during shutdown	I_{SS3}	$V_{CE}=0V$		-	0.02	0.5	μA	1
Feedback voltage temperature coefficient		$T_a=-25-85^{\circ}C$		-	± 50	-	ppm/ $^{\circ}C$	2
Oscillation frequency	Fosc	-		0.8	1.0	1.2	MHz	1
Max. duty ratio	MAXDUTY	$V_{FB}=V_{FB(S)} \times 0.95$		-	78	-	%	1
PWM/PFM switching duty ratio	PFMDUTY	$V_{FB}=V_{FB(S)} \times 1.5$, no load		-	15	-	%	1
Shutdown pin input voltage	V_{SH}	Measured the oscillation at LX pin		0.75	-	-	V	1
	V_{SL1}	Judged the stop of oscillation at LX pin	$V_{OUT} \geq 1.5V$	-	-	0.3	V	1
	V_{SL2}		$V_{OUT} < 1.5V$	-	-	0.2	V	1
Shutdown pin input voltage	I_{SH}	$V_{CE}=V_{FB(S)} \times 0.95$		-0.1	-	0.1	μA	1
	I_{SL}	$V_{CE}=0V$		-0.1	-	0.1	μA	1
Soft start time	tss	-		-	2	-	mS	2
Efficiency	EFFI	-		-	90	-	%	2

Note:

- $V_{OUT(S)}$ is the set output voltage value, and V_{OUT} is the typical value of the output voltage.
- $V_{OUT(S)}$ can be set by using the rate of V_{FB} and output voltage setting resistors (R1, R2).
- $V_{FB(S)}$ is the set output voltage value.
- V_{DD}/V_{OUT} separate type:
 $1.8V \leq V_{DD} < 6V$ is recommended to stabilize the output voltage and oscillation frequency.

Test Circuit

1.

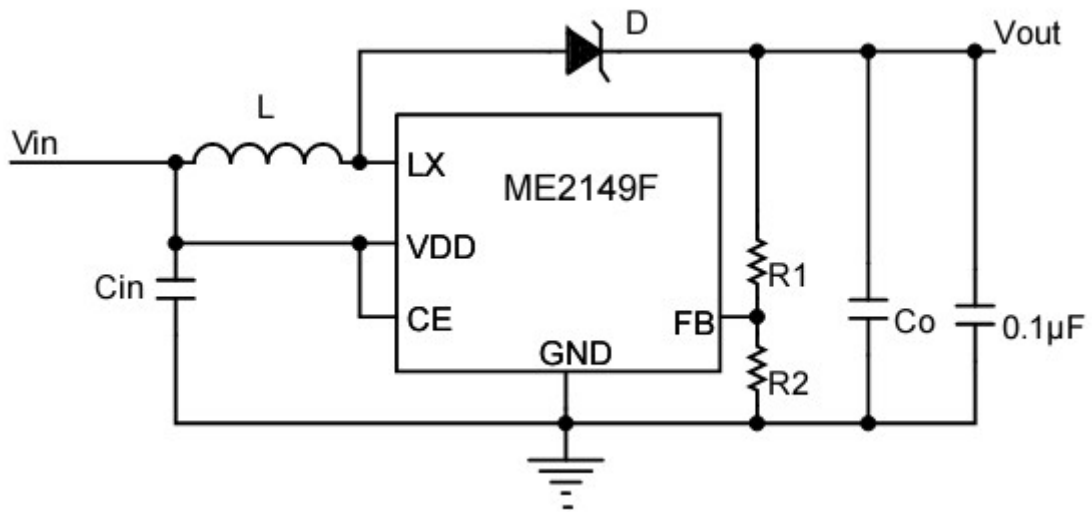

2.

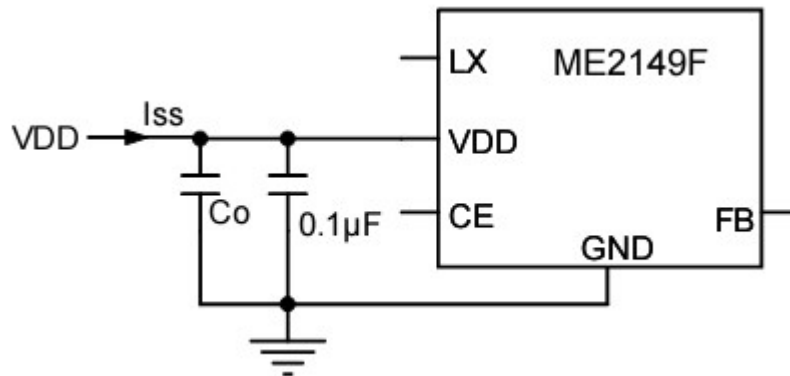

External parts (suggest)

- 1、 Diode use Schottky diode such as SS14 or SS34 (forward voltage drop:0.2V)
- 2、 Inductor: 3.3µH (r<30mΩ)
- 3、 Capacitor: ceramic capacitor 22µF (It is best to use two parallel connection ceramic capacitors)
- 4、 Feed back resistors:R1+R2<50KΩ

External parts selection for DC/DC converter

The relationship between major characteristics of the step-up circuit and characteristics parameters of the external parts are shown in Figure 1.

For larger output current?	For high efficiency?		For smaller ripple voltage?
	Operation efficiency	Stand-by efficiency	
Smaller inductance	Larger inductance		
Smaller DC resistance of inductor			
Large output capacitance			Large output capacitance

Figure 1 Relationship between major characteristics of the step-up circuit and external parts

1. Inductor

An inductance has strong influence on maximum output current I_{OUT} and efficiency η .

Figure 2 shows the relation between I_{OUT} , and η characteristics to L of ME2149.

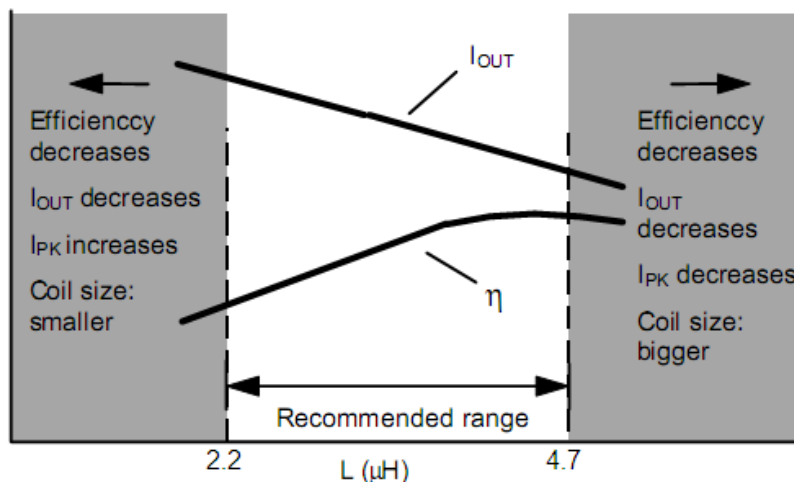

Figure 2 L— I_{OUT} and η characteristics

The peak current (I_{PK}) increases by decreasing L and the stability of a circuit improves and I_{OUT} increases. If L is furthermore made small, efficiency falls and in running short, I_{OUT} decreases. (Based on the current drive capability of external switching transistor.)

The loss of I_{PK} by the switching transistor decreases by increasing L and the efficiency becomes maximum at a certain L value. Further increasing L decreases efficiency due to the loss of DC resistance of the coil. Also, I_{OUT} decreases, too.

Oscillation frequency is higher, smaller one can be chose and also makes coil smaller. The recommended inductances are 2.2 to 4.7 μ H inductor for ME2149.

Choose a value for L by referring to the reference data because the maximum output current is due to the input voltage in an actual case. Choose an inductor so that I_{PK} does not exceed the allowable current. Exceeding the allowable current of the inductor causes magnetic saturation, remarkable low efficiency and destruction of the IC chip due to a large current.

I_{PK} in uncontinuous mode is calculated from the following equation:

$$I_{PK} = \sqrt{\frac{2I_{OUT}(V_{OUT} + V_D - V_{IN})}{f_{OSC} \cdot L}} (A)$$

f_{OSC} = oscillation frequency, $V_{DD} = 0.4 V$.

2. Diode

Use an external diode that meets the following requirements:

- Low forward voltage: ($V_F < 0.3 V$)
- High switching speed: (50 ns max.)
- Reverse voltage: $V_{OUT} + V_F$ or more
- Rated current: I_{PK} or more

3. Capacitor (C_{IN} , C_O)

To improve efficiency, an input capacitor (C_{IN}) lowers the power supply impedance and averages the input current. Select C_{IN} according to the impedance of the power supply used. The recommended capacitance is 10 μ F for the ME2149.

An output capacitor (C_{OUT}), which is used to smooth the output voltage, requires a capacitance larger than that of the step-down type because the current is intermittently supplied from the input to the output side in the step-up type. A 22 μ F ceramic capacitor is recommended for the ME2149. However, a higher capacitance is recommended if the output voltage is high or the load current is large. If the output voltage or load current is low, about 10 μ F can be used without problems.

Select C_{OUT} after sufficient evaluation with actual application.

A ceramic capacitor can be used for both the input and output.

4. Precautions

- Mount external capacitors, a diode, and a coil as close as possible to the IC.
- Unique ripple voltage and spike noise occur in switching regulators. Because they largely depend on the coil and the capacitor used, check them using an actually mounted model.
- Make sure dissipation of the switching transistor (especially at a high temperature) does not exceed the allowable power dissipation of the package.
- The performance of this IC varies depending on the design of the PCB patterns, peripheral circuits and external

parts. Thoroughly test all settings with your device. Also, try to use recommended external parts.

Typical Application Circuit

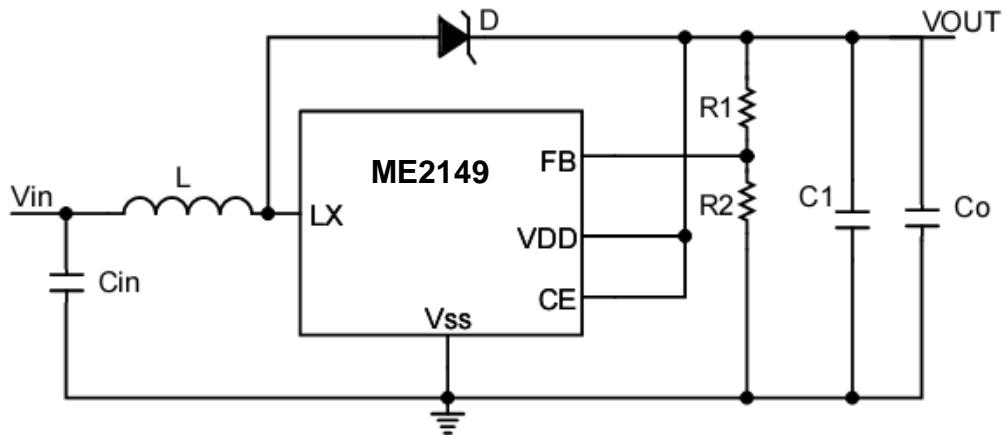

For FB and external 1

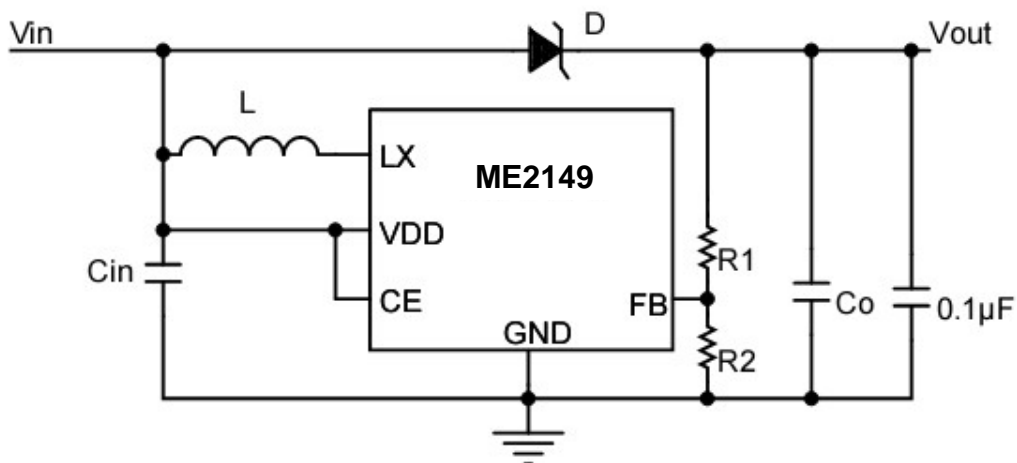

For FB and external 2

Note:

1. If VDD connected to Vin , Vin should above 2.5V.
2. ME2149F has three packages, suggestion: SOT23-5 loading is not more than 1A; SOT89-5 is not more than 1.5A; SOP8 is not more than 2A.

Typical Performance Characteristics

Vout vs. Output Current

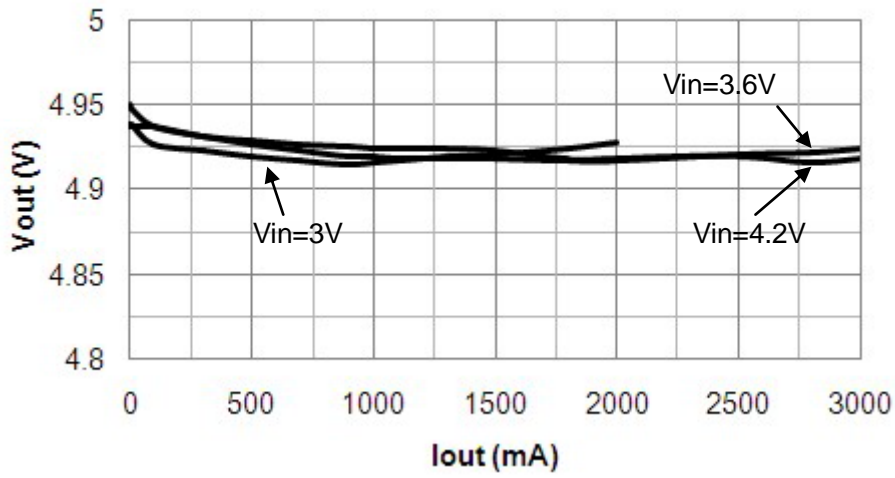

Efficiency vs. Output Current

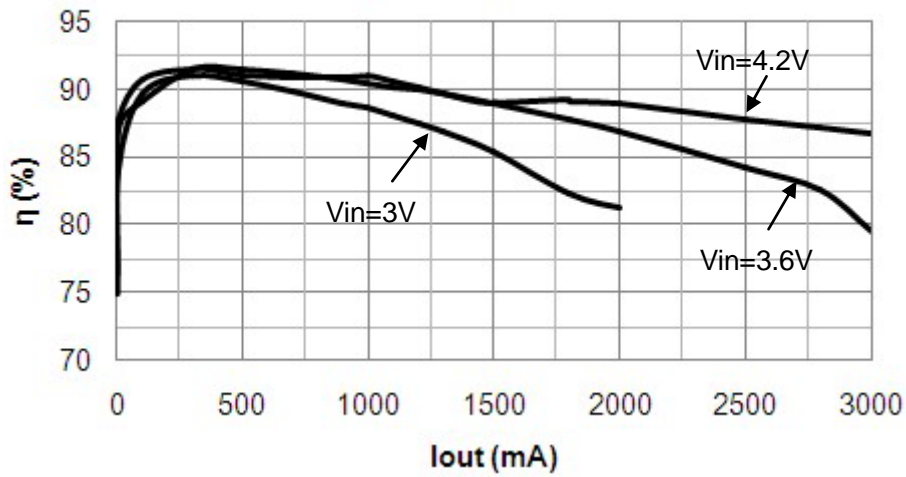

Package Dimension

Package type:SOT23-5 Unit:mm(inch)

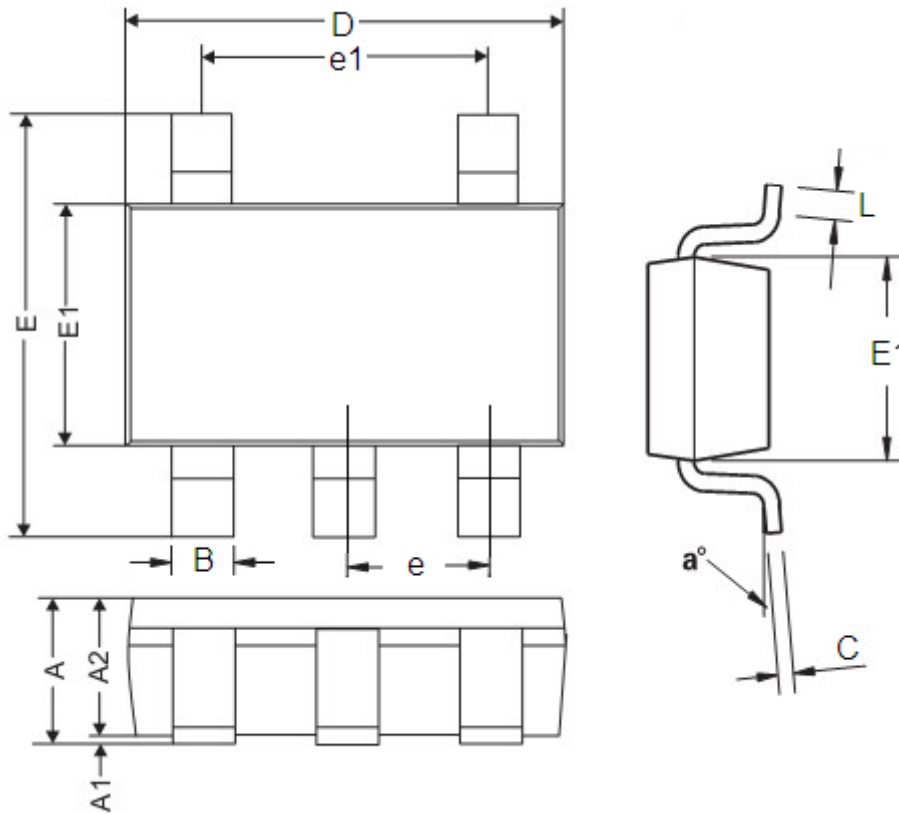

DIM	Millimeters		Inches	
	Min	Max	Min	Max
A	0.9	1.45	0.0354	0.0570
A1	0	0.15	0	0.0059
A2	0.9	1.3	0.0354	0.0511
B	0.2	0.5	0.0078	0.0196
C	0.09	0.26	0.0035	0.0102
D	2.7	3.10	0.1062	0.1220
E	2.2	3.2	0.0866	0.1181
E1	1.30	1.80	0.0511	0.0708
e	0.95REF		0.0374REF	
e1	1.90REF		0.0748REF	
L	0.10	0.60	0.0039	0.0236
a°	0°	30°	0°	30°

Package Dimension

Package type:SOT89-5 Unit:mm(inch)

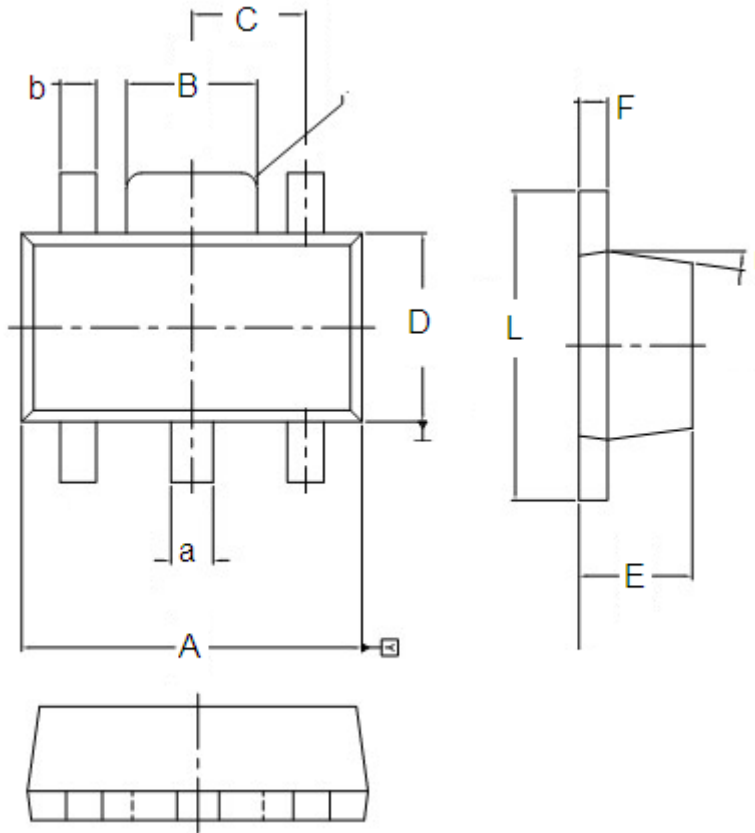

DIM	Millimeters		Inches	
	Min	Max	Min	Max
A	4.4	4.6	0.173	0.181
a	0.5	0.62	0.02	0.024
B	1.63	1.83	0.064	0.072
b	0.44	0.54	0.017	0.021
C	Type:1.5		Type:0.059	
D	2.4	2.6	0.094	0.102
E	1.4	1.6	0.054	0.063
F	0.35	0.43	0.013	0.017
L	3.95	4.25	0.155	0.167
r	Type:8 ⁰		Type:8 ⁰	

Package Dimension

Package type:SOP8 Unit:mm(inch)

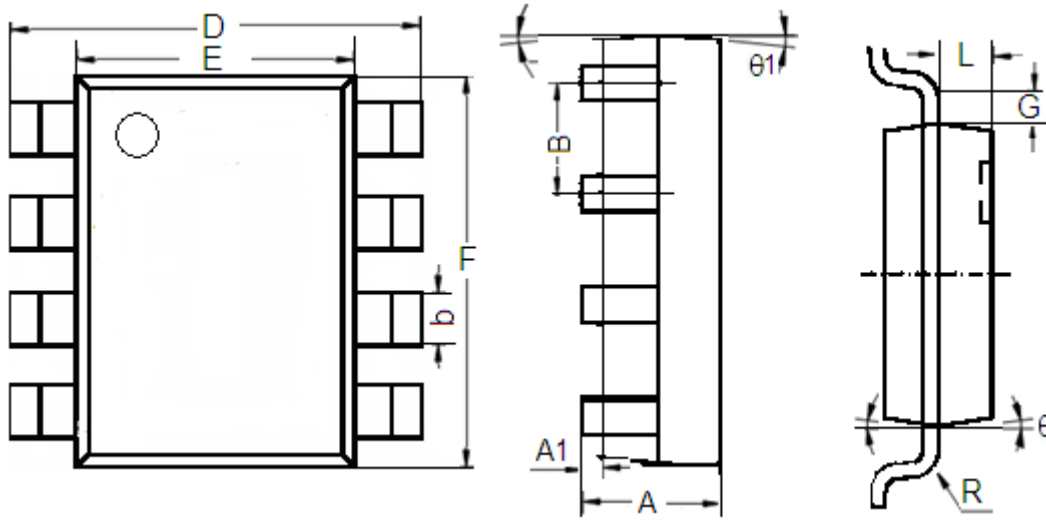

Character	Dimension (mm)		Dimension (Inches)	
	Min	Max	Min	Max
A	1.350	1.750	0.053	0.069
A1	0.1	0.3	0.004	0.012
B	1.27(Typ.)		0.05(Typ.)	
b	0.330	0.510	0.013	0.020
D	5.8	6.2	0.228	0.244
E	3.800	4.000	0.150	0.157
F	4.7	5.1	0.185	0.201
L	0.675	0.725	0.027	0.029
G	0.32(Typ.)		0.013(Typ.)	
R	0.15(Typ.)		0.006(Typ.)	
θ1	7°		7°	
θ	8°		8°	

- The information described herein is subject to change without notice.
- Nanjing Micro One Electronics Inc is not responsible for any problems caused by circuits or diagrams described herein whose related industrial properties, patents, or other rights belong to third parties. The application circuit examples explain typical applications of the products, and do not guarantee the success of any specific mass-production design.
- Use of the information described herein for other purposes and/or reproduction or copying without the express permission of Nanjing Micro One Electronics Inc is strictly prohibited.
- The products described herein cannot be used as part of any device or equipment affecting the human body, such as exercise equipment, medical equipment, security systems, gas equipment, or any apparatus installed in airplanes and other vehicles, without prior written permission of Nanjing Micro One Electronics Inc.
- Although Nanjing Micro One Electronics Inc exerts the greatest possible effort to ensure high quality and reliability, the failure or malfunction of semiconductor products may occur. The user of these products should therefore give thorough consideration to safety design, including redundancy, fire-prevention measures, and malfunction prevention, to prevent any accidents, fires, or community damage that may ensue.