

N-Channel 60V (D-S) MOSFET, ESD Protection

GENERAL DESCRIPTION

The ME2N70023D2-G is the N-Channel logic enhancement mode power field effect transistors are produced using high cell density, DMOS trench technology. This high density process is especially tailored to minimize on-state resistance. These devices are particularly suited for low voltage application such as cellular phone and notebook computer power management and other battery powered circuits , and low in-line power loss are needed in a very small outline surface mount package.

PIN CONFIGURATION

Small SOT-23
Top View

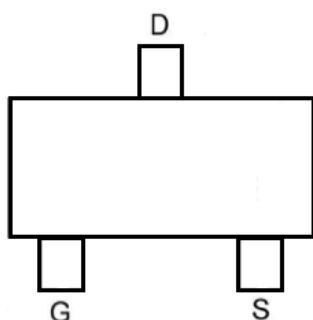

FEATURES

- $R_{DS(ON)} \leq 3\Omega @ V_{GS}=10V$
- $R_{DS(ON)} \leq 4\Omega @ V_{GS}=4.5V$
- $R_{DS(ON)} \leq 4.5\Omega @ V_{GS}=3V$
- ESD Protection HBM $\geq 2KV$
- Super high density cell design for extremely low $R_{DS(ON)}$
- Exceptional on-resistance and maximum DC current capability
- Capable doing Cu wire bonding

APPLICATIONS

- Power Management in Note book
- Portable Equipment
- Battery Powered System
- Load Switch
- DSC

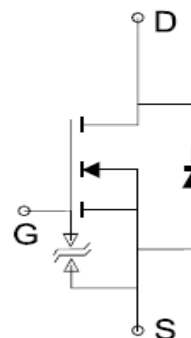

N-Channel MOSFET

Ordering Information: ME2N7002D2S-G (Green product-Halogen free)

Absolute Maximum Ratings (TA=25°C Unless Otherwise Noted)

Parameter	Symbol	Maximum Ratings	Unit
Drain-Source Voltage	V _{DS}	60	V
Gate-Source Voltage	V _{GS}	±20	V
Continuous Drain	TA=25°C	I _D	A
	TA=70°C	I _D	
Pulsed Drain Current	I _{DM}	1.1	A
Maximum Power Dissipation	TA=25°C	P _D	W
	TA=70°C	P _D	
Operating Junction Temperature	T _J	-55 to 150	°C
Thermal Resistance-Junction to Ambient*	R _{θJA}	350	°C/W

* The device mounted on 1in² FR4 board with 2 oz copper

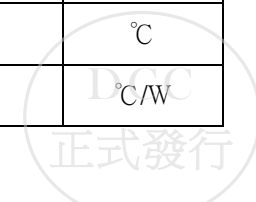

N-Channel 60V (D-S) MOSFET, ESD Protection
Electrical Characteristics ($T_A=25^\circ\text{C}$ Unless Otherwise Specified)

Symbol	Parameter	Limit	Min	Typ	Max	Unit
STATIC						
BV _{DSS}	Drain-Source Breakdown Voltage	$V_{GS}=0V, I_D=250\ \mu A$	60			V
V _{GS(th)}	Gate Threshold Voltage	$V_{DS}=V_{GS}, I_D=250\ \mu A$	1		2.5	V
I _{GSS}	Gate-Body Leakage	$V_{DS}=0V, V_{GS}=\pm 20V$			± 10	μA
I _{DSS}	Zero Gate Voltage Drain Current	$V_{DS}=60V, V_{GS}=0V$			1	μA
R _{DS(ON)}	Drain-Source On-Resistance*	$V_{GS}=10V, I_D=500mA$		1.8	3	Ω
		$V_{GS}=4.5V, I_D=200mA$		2.3	4	
		$V_{GS}=3V, I_D=10mA$		3.8	4.5	
V _{SD}	Diode Forward Voltage *	$I_S=200mA, V_{GS}=0V$		0.82	1.3	V
DYNAMIC						
Q _g	Total Gate Charge	$V_{DS}=30V, V_{GS}=10V, I_D=200mA$		3.7		nC
Q _g	Total Gate Charge	$V_{DS}=30V, V_{GS}=4.5V, I_D=200mA$		1.4		
Q _{gs}	Gate-Source Charge			2		
Q _{gd}	Gate-Drain Charge			0.2		
C _{iss}	Input Capacitance	$V_{DS}=25V, V_{GS}=0V, f=1MHz$		15		pF
C _{oss}	Output Capacitance			2		
C _{rss}	Reverse Transfer Capacitance			1		
t _{d(on)}	Turn-On Delay Time	$V_{DS}=30V, R_L=150\ \Omega$ $V_{GS}=10V, R_G=10\ \Omega$ $I_D=200mA$		3.7		ns
t _r	Turn-On Rise Time			21.7		
t _{d(off)}	Turn-Off Delay Time			5.9		
t _f	Turn-Off Fall Time			21.4		

 Notes: a, pulse test: pulse width $\leq 300\ \mu s$, duty cycle $\leq 2\%$, Guaranteed by design, not subject to production testing.

b. Matsuki Electric/ Force mos reserves the right to improve product design, functions and reliability without notice.



N-Channel 60V (D-S) MOSFET, ESD Protection

Typical Characteristics (T_J =25°C Noted)

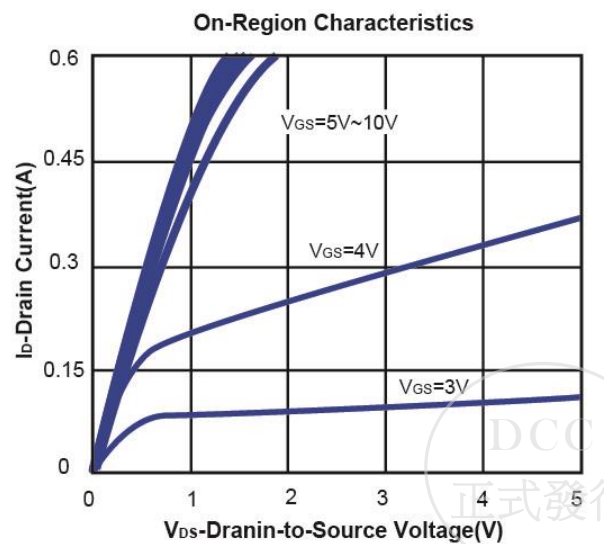
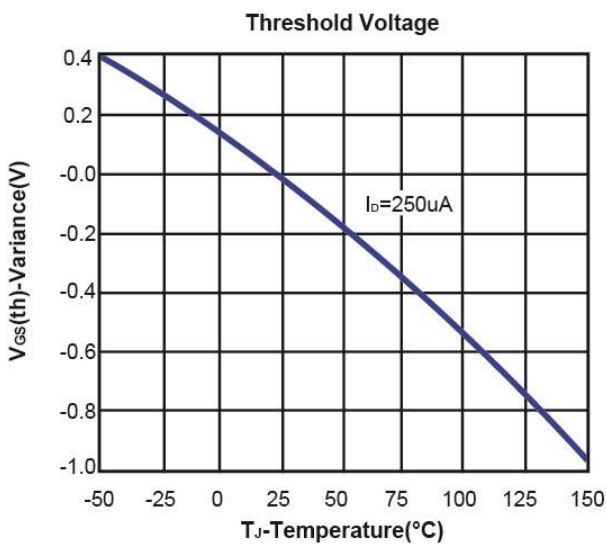
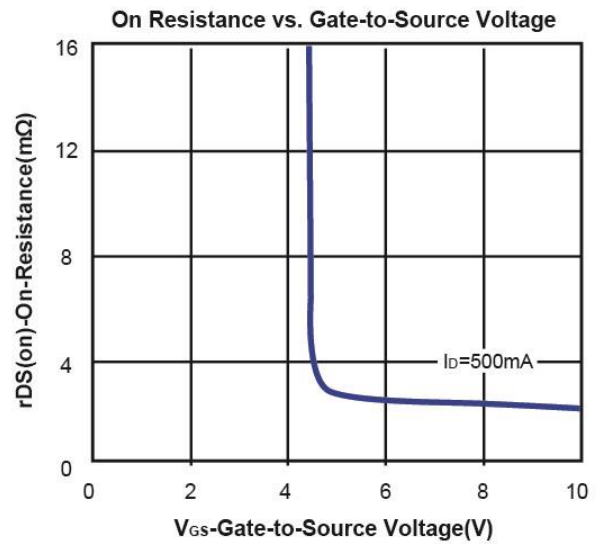
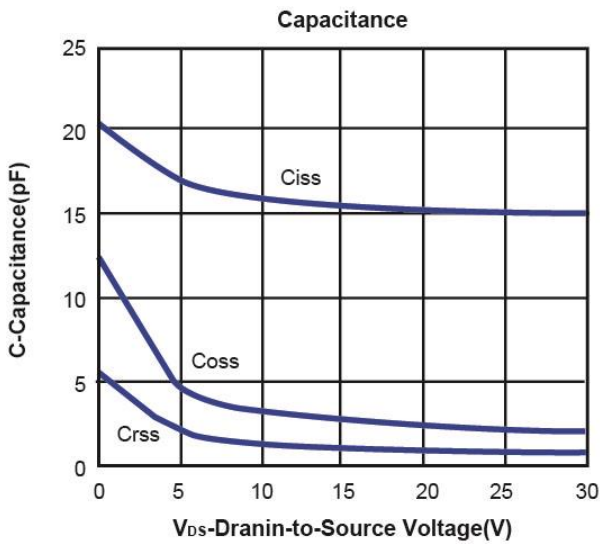
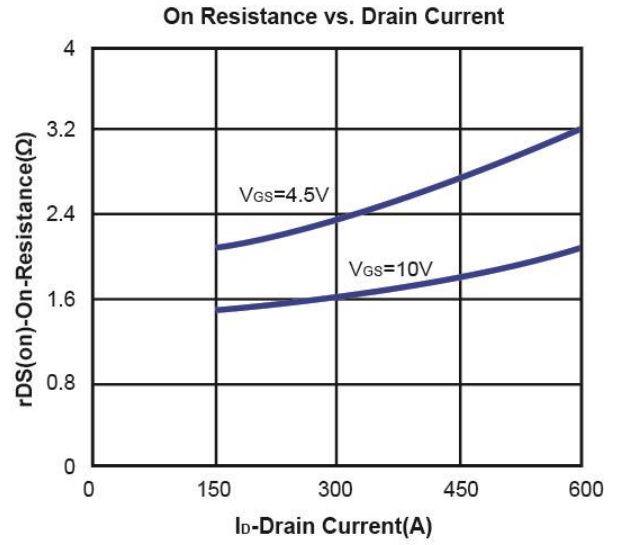
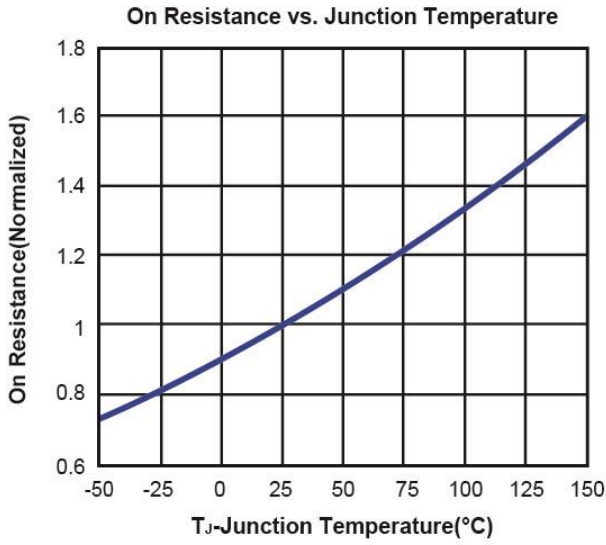

N-Channel 60V (D-S) MOSFET, ESD Protection

Typical Characteristics (T_J =25°C Noted)

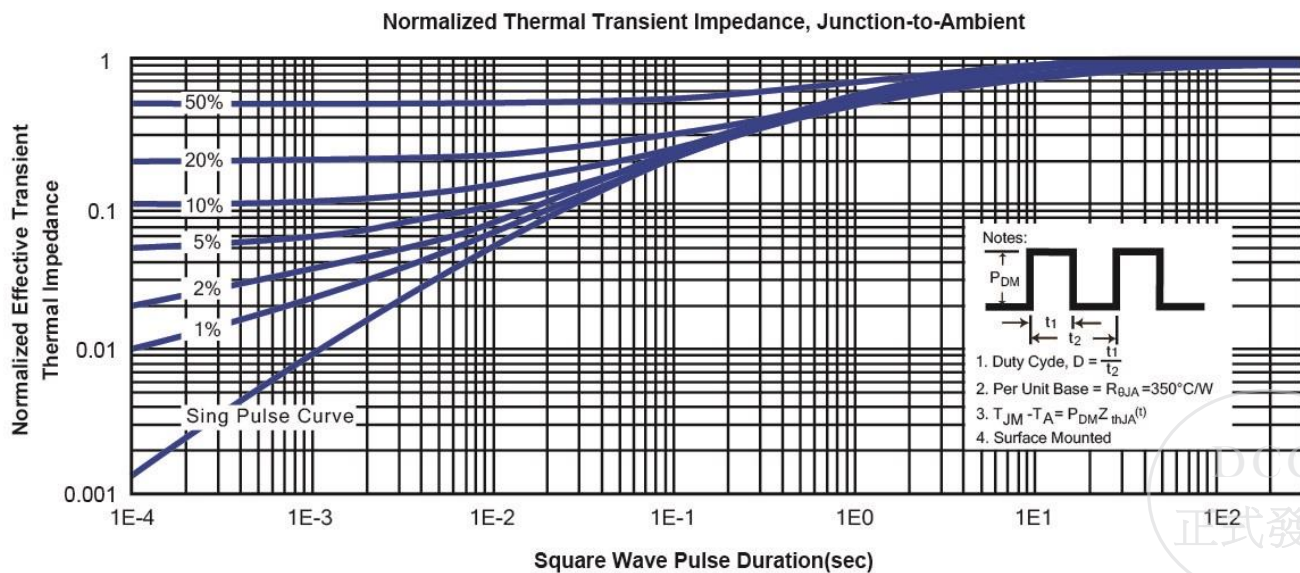
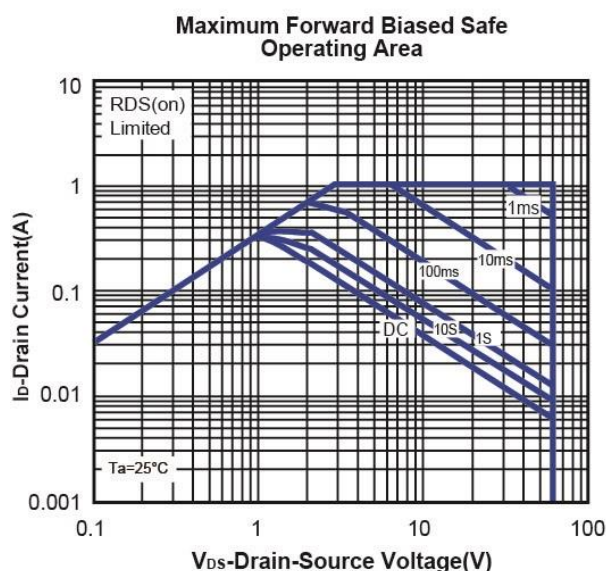
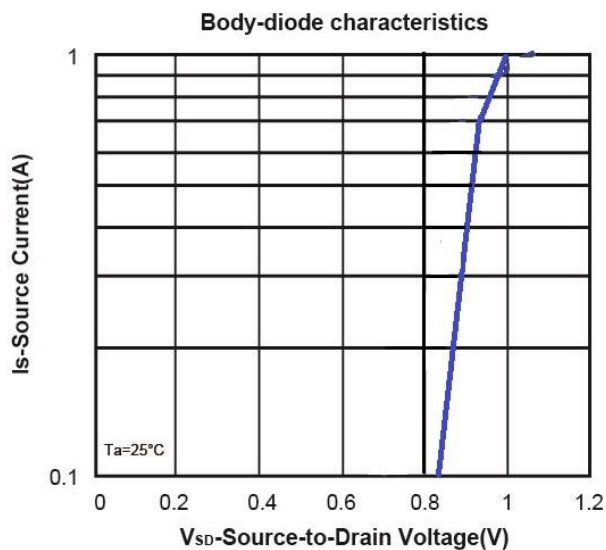
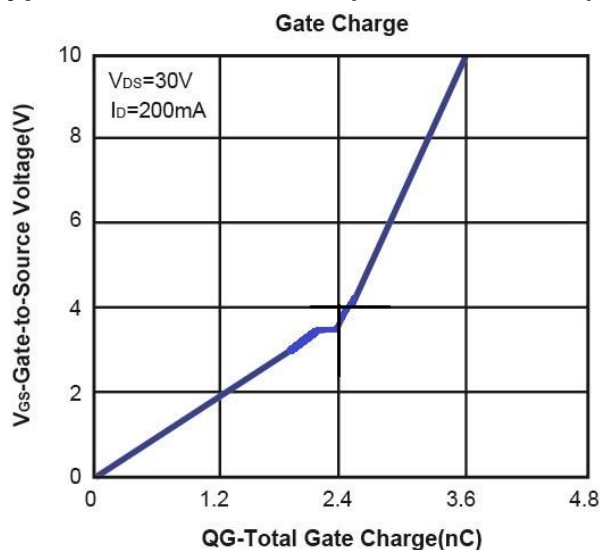

Small SOT-23 Package

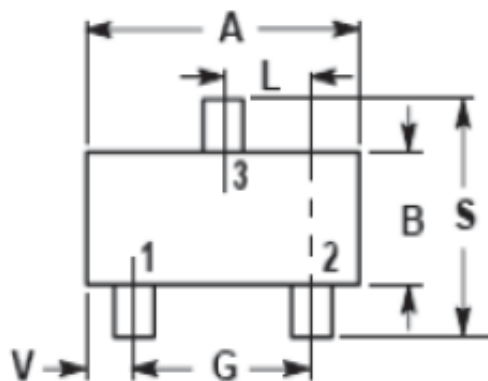

NOTES:

1. DIMENSIONING AND TOLERANCING PER ANSI Y14.5M, 1982.
2. CONTROLLING DIMENSION: INCH.

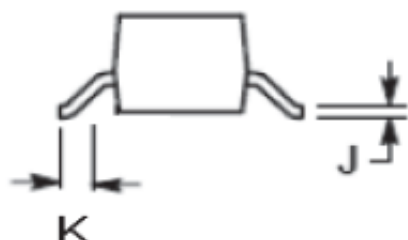
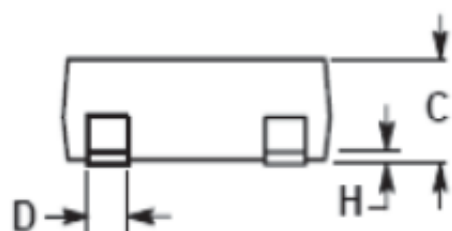

DIM	INCHES		MILLIMETERS	
	MIN	MAX	MIN	MAX
A	0.1102	0.1197	2.80	3.04
B	0.0472	0.0551	1.20	1.40
C	0.0350	0.0440	0.89	1.11
D	0.0150	0.0200	0.37	0.5
G	0.0701	0.0807	1.78	2.04
H	0.0005	0.0040	0.013	0.100
J	0.0034	0.0070	0.085	0.177
K	0.007	-	0.018	-
L	0.0350	0.0401	0.89	1.02
S	0.0830	0.1039	2.10	2.64
V	0.0177	0.0236	0.45	0.60



N-Channel 60V (D-S) MOSFET, ESD Protection

Device name: ME2N70023D2-G

Package: SOT-23

Marking Code

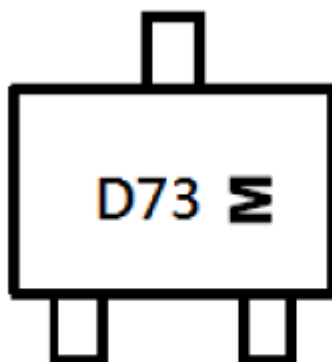

D73:Device Marking Code
M:Date code

MONTH CODE

ODD YEARS(2007,2009)

Jan	1
Feb	2
Mar	3
Apr	4
May	5
Jun	6
Jul	7
Aug	8
Sep	9
Oct	T
Nov	V
Dec	C

EVEN YEARS(2006,2008)

Jan	E
Feb	F
Mar	H
Apr	J
May	K
Jun	L
Jul	N
Aug	P
Sep	U
Oct	X
Nov	Y
Dec	Z

DCC
正式發行