

## 1A Step-Down DC-DC Converter ME3103

### General Description

The ME3103 is a step-down current-mode, DC-DC converter. At heavy load, the constant-frequency PWM control performs excellent stability and transient response. To ensure the longest battery life in portable applications, the ME3103 provides a power-saving pulse -Skipping Modulation (PSM) mode to reduce quiescent current under light load operation to save power.

The ME3103 supports a range of input voltages from 2.5V to 5.5V, allowing the use of a single Li+/Li-polymer cell, multiple Alkaline/NiMH cell, USB, and other standard power sources. The output voltage is adjustable from 0.6V to the input voltage, while the part number suffix ME3103 indicates pre-set output voltage of 3.3V, 2.8V, 2.5V, 1.8V, 1.5V, 1.2V or adjustable. All versions employ internal power switch and synchronous rectifier for to minimize external part count and realize high efficiency. During shutdown, the input is disconnected from the output and the shutdown current is less than 0.1 $\mu$ A. Other key features include under-voltage lockout to prevent deep battery discharge.

### Features

- Efficiency up to 96%
- Only 40 $\mu$ A (TYP.) Quiescent Current
- Output Current: Up to 1A
- Internal Synchronous Rectifier
- 1.5MHz Switching Frequency
- Soft Start
- Under-Voltage Lockout
- Short Circuit Protection
- Thermal Shutdown

### Applications

- Cellular Phone
- Portable Electronics
- Wireless Devices
- Cordless Phone
- Computer Peripherals
- Battery Powered Widgets
- Electronic Scales
- Digital Frame

Selection Guide

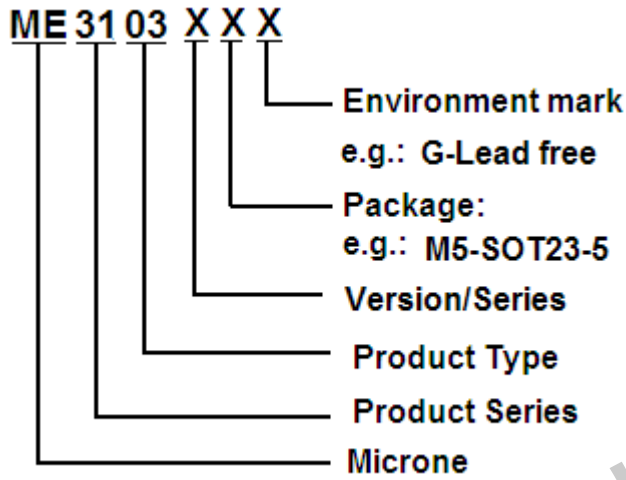

Typical Application

Fixed Output Voltage

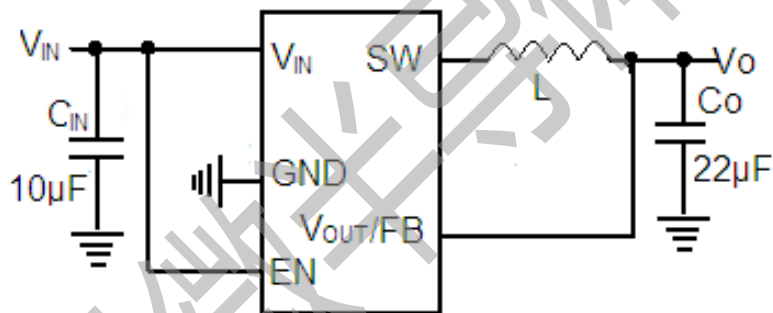

Adjustable Output Voltage

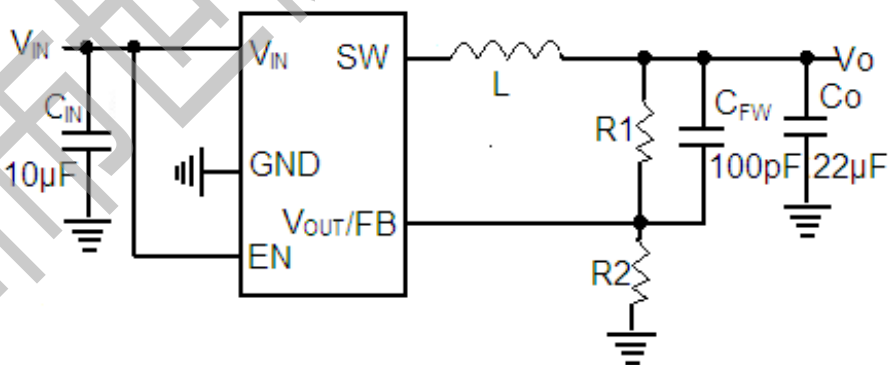

$$V_o = 0.6 \times \left( 1 + \frac{R1}{R2} \right)$$

Pin Configuration

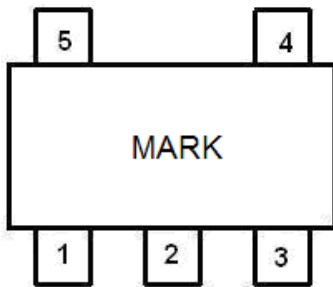

SOT23-5

Pin information

Pin Number	Name	Function
1	EN	Chip Enable
2	GND	Ground
3	SW	Switch
4	V <sub>IN</sub>	Input
5	FB	Feedback

Absolute Maximum Ratings

Parameter	Symbol	Rating	Unit
Power supply voltage, V <sub>IN</sub>	V <sub>IN</sub>	-0.3~6.0	V
voltage at EN, FB Pin	V <sub>EN</sub> , V <sub>FB</sub>	-0.3~V <sub>IN</sub>	V
voltage at SW Pin	V <sub>SW</sub>	-0.3~V <sub>IN</sub> + 0.3	V
Internal Power Dissipation, (SOT23-5)	P <sub>D</sub>	300	mW
Operating Ambient Temperature	T <sub>opr</sub>	-40~85	°C
Storage Temperature	T <sub>stg</sub>	-40~+150	°C
Soldering temperature and time	T <sub>solder</sub>	260°C, 10S	°C

Block Diagram

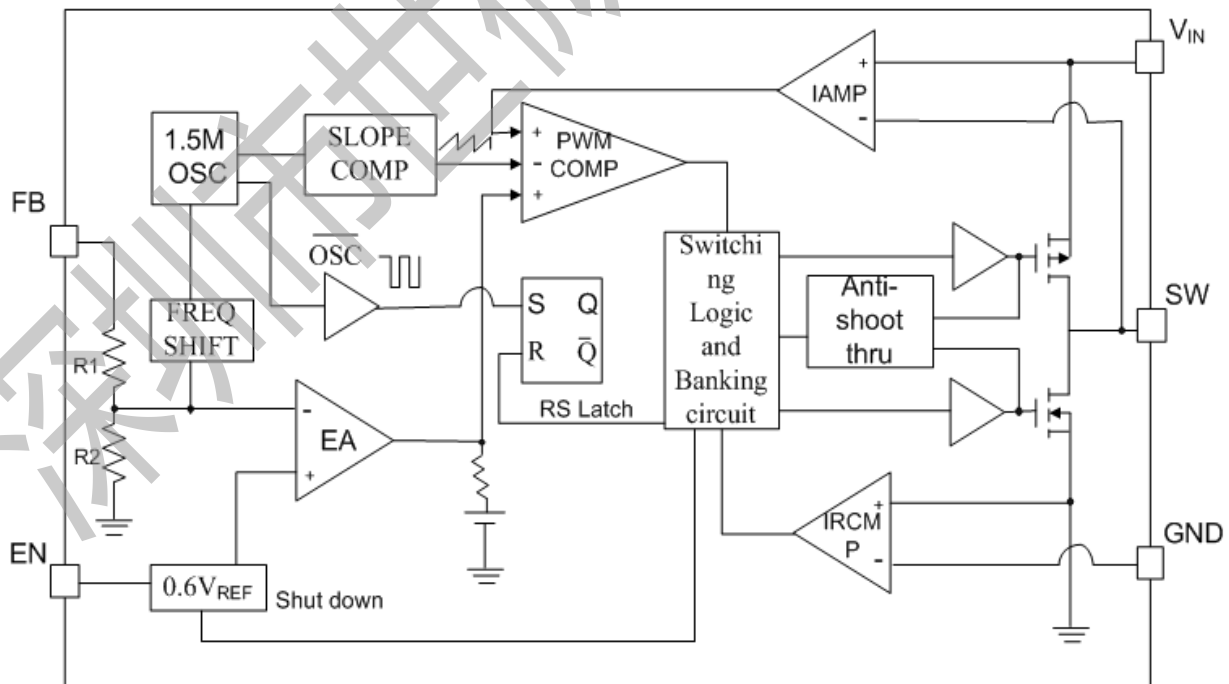

## Electrical Characteristics

( $V_{IN} = V_{EN} = 3.6V$ ,  $V_O = 1.8V$ ,  $C_{IN} = 10\mu F$ ,  $C_O = 22\mu F$ ,  $L = 4.7\mu H$ ,  $C_{FW} = 100pF$ ,  $T_A = 25^\circ C$ , unless otherwise noted.)

Parameter	Symbol	Test condition	Min	Typ.	Max	Unit	
Input voltage range	$V_{IN}$		2.5	-	5.5	V	
Regulated Feedback Voltage	$V_{FB}$		0.588	0.6	0.612	V	
Reference Voltage Line Regulation	$\Delta V_{FB}$		-	0.3	-	%/V	
Regulated Output Voltage Accuracy	$V_O$	$I_O = 100mA$	-3	-	+3	%	
Peak Inductor Current	$I_{PK}$	$V_{IN} = V_{EN} = 3V, V_{FB} = 0.5V$ or $V_O = 90\%$	-	1.5	-	A	
Output Voltage Line Regulation	LNR	$V_{IN} = V_{EN} = 2.5V$ to $5V, I_O = 10mA$	-	0.2	0.5	%/V	
Output Voltage Load Regulation	LDR	$I_O = 1.0mA$ to $800mA$	-	0.5	1.5	%	
Quiescent Current	$I_Q$	No load	-	40	70	$\mu A$	
Shutdown Current	$I_{SD}$	$V_{EN} = 0V$	-	0.1	1	$\mu A$	
Oscillator Frequency	$F_{OSC}$	$V_O = 100\%$	1.2	1.5	1.8	MHz	
		$V_{FB} = 0V$ or $V_O = 0V$		500		KHz	
Drain-Source On-State Resistance	$R_{DS(ON)}$	$I_{DS} = 100mA$	PMOS	-	0.3	0.45	$\Omega$
			NMOS	-	0.35	0.5	$\Omega$
SW Leakage Current	$I_{LSW}$		-	$\pm 0.01$	1	$\mu A$	
High Efficiency	$\eta$		-	96	-	%	
EN Threshold High	$V_{EH}$		1.5	-	-	V	
EN Threshold Low	$V_{EL}$		-	-	0.3	V	
EN Leakage Current	$I_{EN}$		-	$\pm 0.01$	1	$\mu A$	
Over Temperature Protection	OTP		-	160	-	$^\circ C$	
OTP Hysteresis	OTH		-	40	-	$^\circ C$	

## Typical Performance Characteristics

1. Efficiency VS Output Current ( $V_O=1.8V$ )

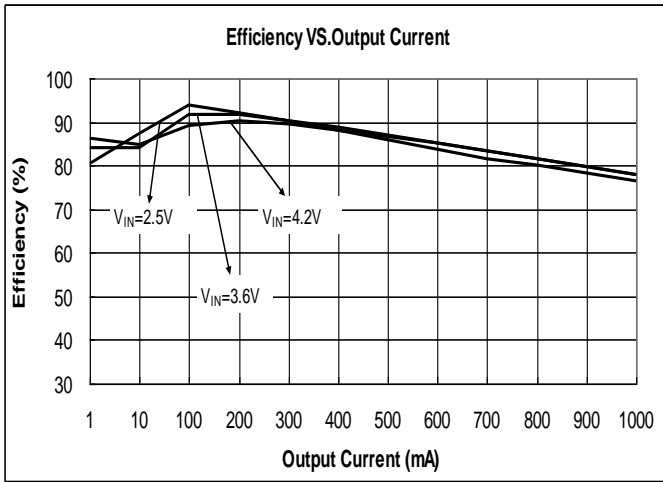

Efficiency VS Output Current ( $V_O=3.3V$ )

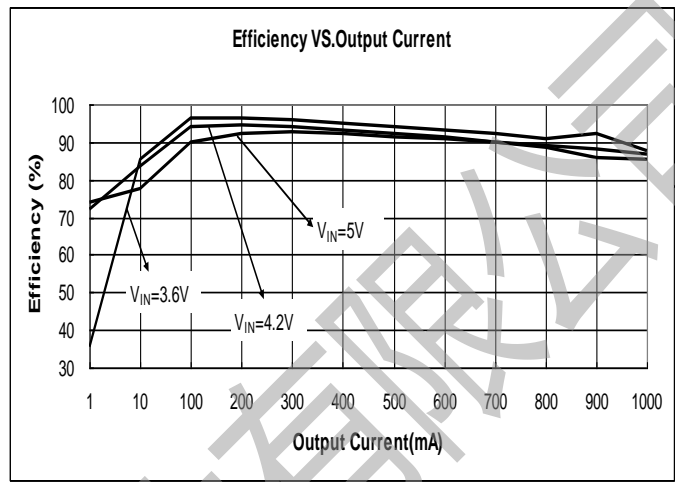

2. Efficiency VS Input Voltage ( $V_O=1.8V$ )

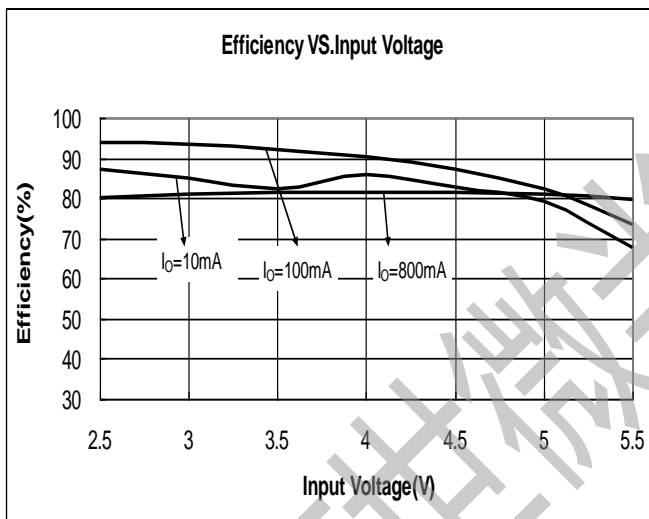

Efficiency VS Input Voltage ( $V_O=3.3V$ )

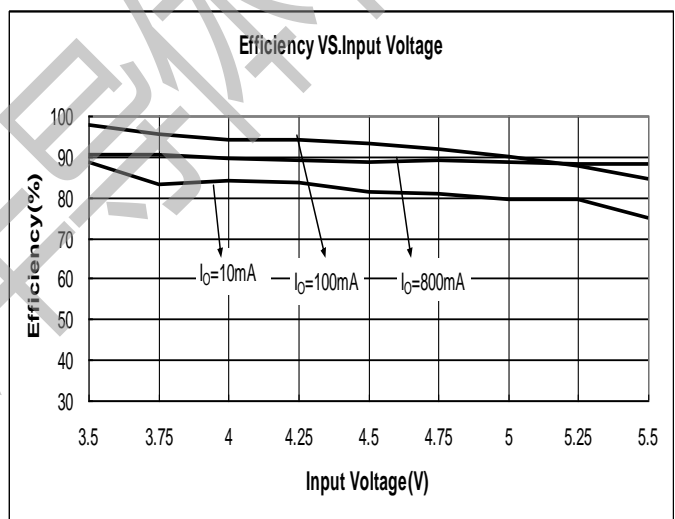

3.  $V_{FB}$  VS Input Voltage

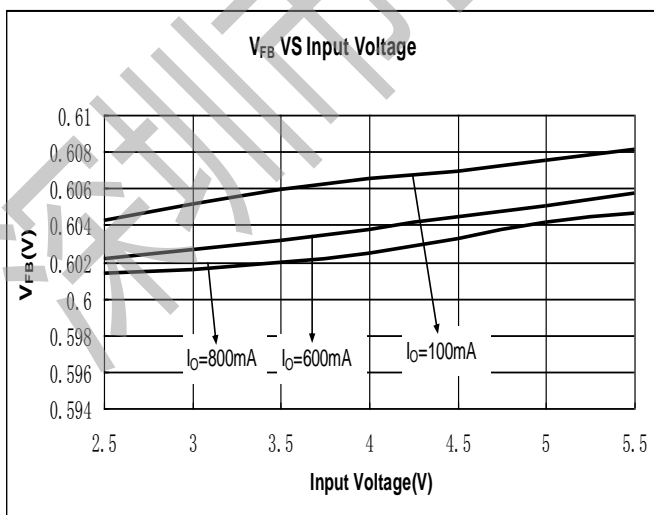

4.  $V_{FB}$  VS Output Current

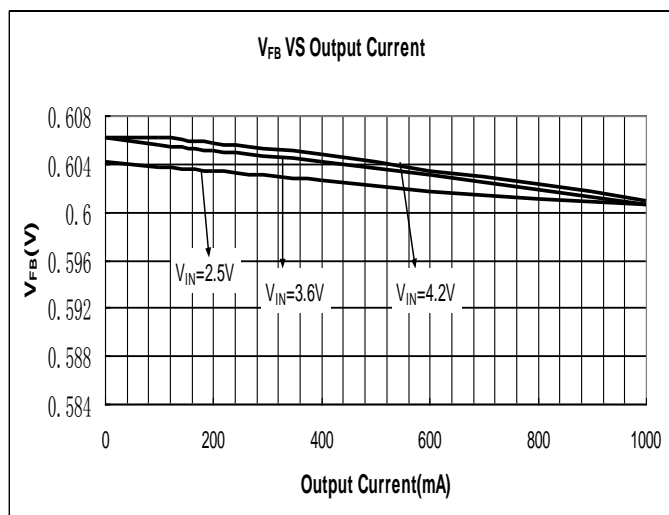

5. Output Voltage VS Output Current( $V_O=1.8V$ )

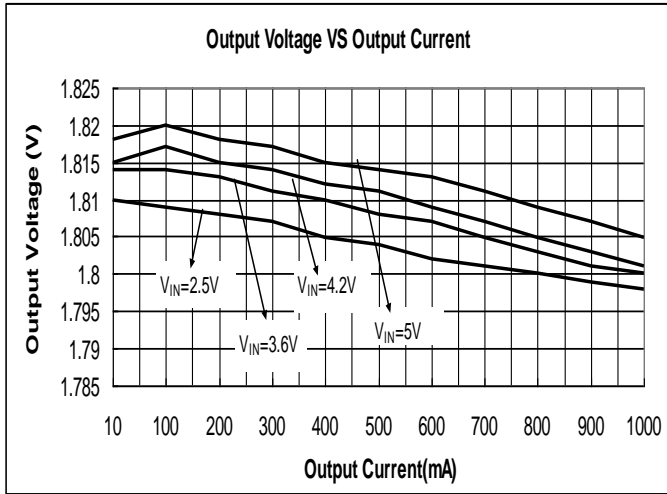

6.  $V_{FB}$  VS Temperature

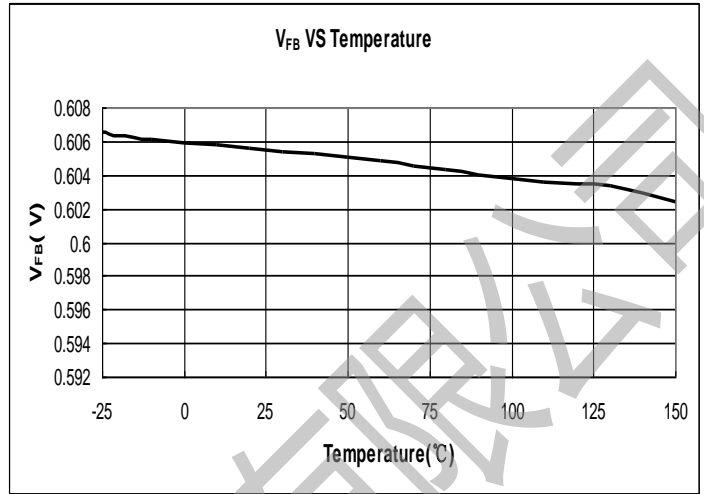

7. Dynamic Supply Current VS Input Voltage ( $V_O=1.8V$ )

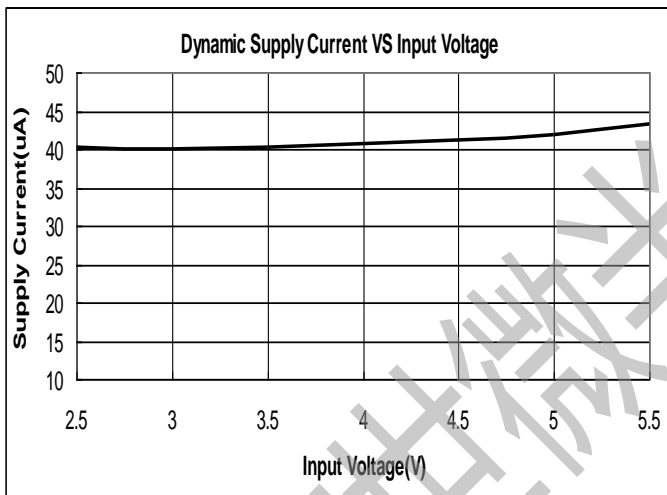

8. Dynamic Supply Current VS Temperature ( $V_{IN}=3.6V$ ,  $V_O=1.8V$ )

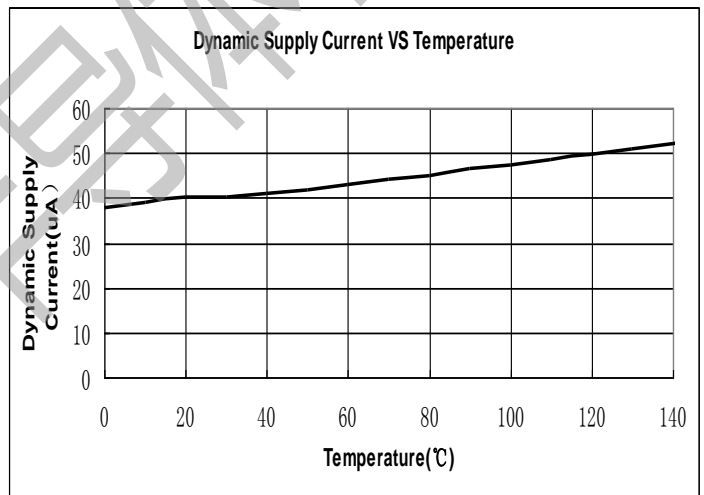

9. Oscillator Frequency VS Input Voltage

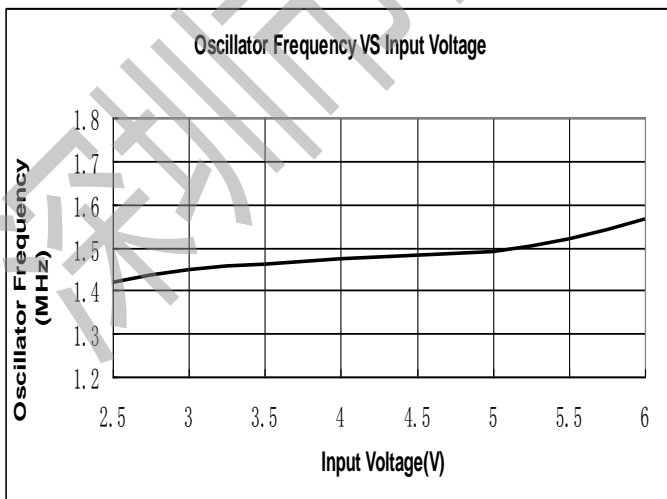

## Application Information

The basic ME3103 application circuit is shown as up figures. External component selection is determined by the load requirement, selecting L first and then  $C_{IN}$  and  $C_{OUT}$ . It is better to use the patch ceramic capacitors at  $C_{OUT}$ .

## Inductor Selection

For most applications, the value of the inductor will fall in the range of  $1\mu\text{H}$  to  $4.7\mu\text{H}$ . Its value is chosen based on the desired ripple current. Large value inductors lower ripple current and small value inductors result in higher ripple currents. Higher  $V_{IN}$  or  $V_{OUT}$  also increases the ripple current as shown in equation 1. A reasonable starting point for setting ripple current is  $\Delta I_L=400\text{mA}$  (40% of 1A).

$$\Delta I_L = \frac{1}{f \times L} V_{OUT} \left( 1 - \frac{V_{OUT}}{V_{IN}} \right) \quad (1)$$

The DC current rating of the inductor should be at least equal to the maximum load current plus half the ripple current to prevent core saturation. Thus, a 1.4A rated inductor should be enough for most applications (1A + 400mA). For better efficiency, choose a low DC-resistance inductor.

$V_O$	1.2V	1.5V	1.8V	2.5V	3.3V
L	2.2 $\mu\text{H}$	2.2 $\mu\text{H}$	4.7 $\mu\text{H}$	4.7 $\mu\text{H}$	4.7 $\mu\text{H}$

## $C_{IN}$ and $C_{OUT}$ Selection

In continuous mode, the source current of the top MOSFET is a square wave of duty cycle  $V_{OUT}/V_{IN}$ . To prevent large voltage transients, a low ESR input capacitor sized for the maximum RMS current must be used. The maximum

RMS capacitor current is given by:  **$C_{IN}$  required**  $I_{RMS} \cong I_{OMAX} \frac{[V_{OUT}(V_{IN} - V_{OUT})]^{1/2}}{V_{IN}}$

This formula has a maximum at  $V_{IN}=2V_{OUT}$ , where  $I_{RMS}=I_{OUT}/2$ . This simple worst-case condition is commonly used for design because even significant deviations do not offer much relief. Note that the capacitor manufacturer's ripple current ratings are often based on 2000 hours of life. This makes it advisable to further derate the capacitor, or choose a capacitor rated at a higher temperature than required. Consult the manufacturer if there is any question.

The selection of  $C_{OUT}$  is driven by the required effective series resistance (ESR). Typically, once the ESR requirement for  $C_{OUT}$  has been met, the RMS current rating generally far exceeds the  $I_{RIPPLE}$  (P-P) requirement. The output ripple  $\Delta V_{OUT}$  is determined by:

$$\Delta V_{OUT} \cong \Delta I_L \left( ESR + \frac{1}{8fC_{OUT}} \right)$$

Where  $f$  = operating frequency,  $C_{OUT}$ =output capacitance and  $\Delta I_L$ = ripple current in the inductor. For a fixed output voltage, the output ripple is highest at maximum input voltage since  $\Delta I$  increases with input voltage.

## Using Ceramic Input and Output Capacitors

Higher values, lower cost ceramic capacitors are now becoming available in smaller case sizes. Their high ripple current, high voltage rating and low ESR make them ideal for switching regulator applications. Using ceramic capacitors can achieve very low output ripple and small circuit size.

When choosing the input and output ceramic capacitors, choose the X5R or X7R dielectric formulations. These dielectrics have the best temperature and voltage characteristics of all the ceramics for a given value and size.

## Thermal consideration

Thermal protection limits power dissipation in the PAM2305. When the junction temperature exceeds 150°C, the OTP (Over Temperature Protection) starts the thermal shutdown and turns the pass transistor off. The pass transistor resumes operation after the junction temperature drops below 120°C.

For continuous operation, the junction temperature should be maintained below 125°C. The power dissipation is defined as:

$$P_D = I_O^2 \frac{V_O R_{DS(ON)H} + (V_{IN} - V_O) R_{DS(ON)L}}{V_{IN}} + (t_{SW} F_S I_O + I_Q) V_{IN}$$

$I_Q$  is the step-down converter quiescent current. The term  $t_{SW}$  is used to estimate the full load step-down converter switching losses.

For the condition where the step-down converter is in dropout at 100% duty cycle, the total device dissipation reduces to:

$$P_D = I_O^2 R_{DS(ON)H} + I_Q V_{IN}$$

Since  $R_{DS(ON)}$ , quiescent current, and switching losses all vary with input voltage, the total losses should be investigated over the complete input voltage range. The maximum power dissipation depends on the thermal resistance of IC package, PCB layout, the rate of surrounding airflow and temperature difference between junction and ambient. The maximum power dissipation can be calculated by the following formula:



$$P_D = \frac{T_{J(MAX)} - T_A}{\theta_{JA}}$$

Where  $T_{J(max)}$  is the maximum allowable junction temperature 125°C.  $T_A$  is the ambient temperature and  $\theta_{JA}$  is the thermal resistance from the junction to the ambient. Based on the standard JEDEC for a two layers thermal test board, the thermal resistance  $\theta_{JA}$  of SOT23-5 package is 250°C/W. The maximum power dissipation at  $T_A = 25^\circ\text{C}$  can be calculated by following formula:  $P = (125^\circ\text{C} - 25^\circ\text{C}) / 250^\circ\text{C/W} = 0.4\text{W}$

### Setting the Output Voltage

The internal reference is 0.6V (Typical). The output voltage is calculated as below:

$$V_o = 0.6 \times \left( 1 + \frac{R1}{R2} \right)$$

The output voltage is given by Table 1.

**Table 1:** Resistor selection for output voltage setting

$V_o$ (V)	R1 (K $\Omega$ )	R2 (K $\Omega$ )
1.2	100	100
1.5	150	100
1.8	200	100
2.5	380	120
3.3	540	120

### 100% Duty Cycle Operation

As the input voltage approaches the output voltage, the converter turns the P-channel transistor continuously on. In this mode the output voltage is equal to the input voltage minus the voltage drop across the P- channel transistor:

$$V_{OUT} = V - I_{LOAD} (R_{DSON} + R_L)$$

where  $R_{DSON}$ = P-channel switch ON resistance,  $I_{LOAD}$ = Output current ,  $R_L$ = Inductor DC resistance

### UVLO and Soft-Start

The reference and the circuit remain reset until the  $V_{IN}$  crosses its UVLO threshold. The ME3103 has an internal soft-start circuit that limits the in-rush current during start-up. This prevents possible voltage drops of the input voltage and eliminates the output voltage overshoot. The soft-start acts as a digital circuit to increase the switch current in several steps to the P-channel current limit (1500mA).

## Short Circuit Protection

The switch peak current is limited cycle-by-cycle to a typical value of 1500mA. In the event of an output voltage short circuit, the device operates with a frequency of 400KHz and minimum duty cycle, therefore the average input current is typically 200mA.

## Thermal Shutdown

When the die temperature exceeds 150°C, a reset occurs and the reset remains until the temperature decrease to 120°C, at which time the circuit can be restarted.

## PCB Layout Check List

When laying out the printed circuit board, the following checklist should be used to ensure proper operation of the ME3103.

1. The power traces, consisting of the GND trace, the SW trace and the  $V_{IN}$  trace should be kept short, direct and wide.
2. Does the  $V_{FB}$  pin connect directly to the feedback resistors? The resistive divider R1/R2 must be connected between the (+) plate of  $C_{OUT}$  and ground.
3. Does the (+) plate of  $C_{IN}$  connect to  $V_{IN}$  as closely as possible? This capacitor provides the AC current to the internal power MOSFETs.
4. Keep the switching node, SW, away from the sensitive  $V_{FB}$  node.
5. Keep the (-) plates of C and  $C_{OUT}$  as close as possible.

Package Information

Package type:SOT23-5 Unit:mm(inch)

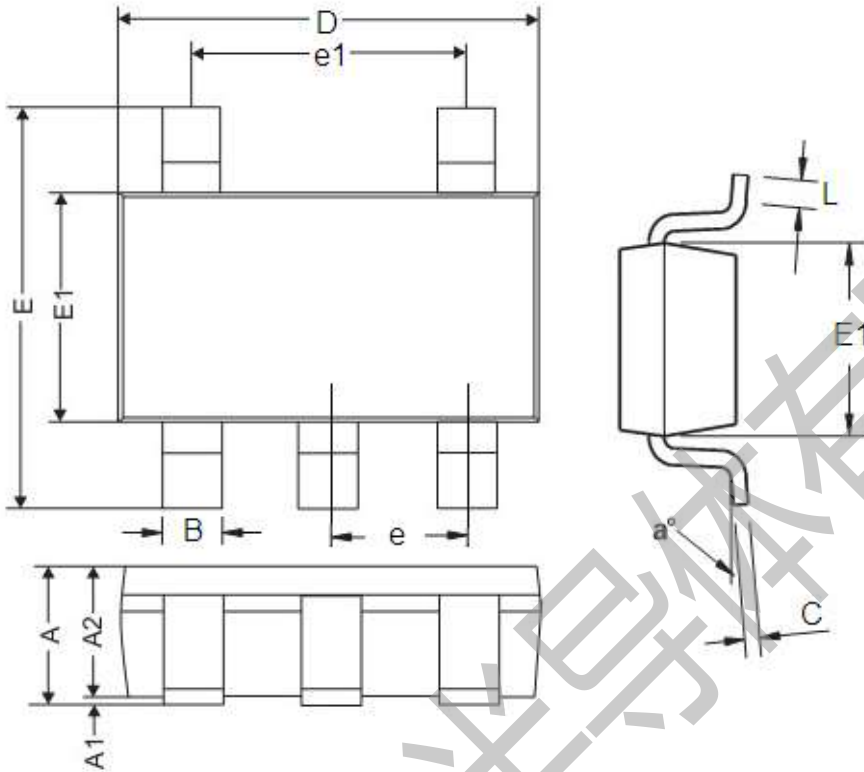

DIM	Millimeters		Inches	
	Min	Max	Min	Max
A	0.9	1.45	0.0354	0.0570
A1	0	0.15	0	0.0059
A2	0.9	1.3	0.0354	0.0511
B	0.2	0.5	0.0078	0.0196
C	0.09	0.26	0.0035	0.0102
D	2.7	3.10	0.1062	0.1220
E	2.2	3.2	0.0866	0.1181
E1	1.30	1.80	0.0511	0.0708
e	0.95REF		0.0374REF	
e1	1.90REF		0.0748REF	
L	0.10	0.60	0.0039	0.0236
a°	0°	30°	0°	30°