

PWM Controller of High-performance Current Mode ME8105

General Description

PWM controller of high-performance current mode is specially designed for AC/DC transformer with high performance and price ratio, which supplies continuous output power of 12W within the range of wide-voltage between 85V and 265V, the output power of peak value can be up to 18W. The combination of optimized reasonable circuit design and bipolar facture technology with high performance and price ratio economizes the whole cost ultimately. The power controller can be applied to the typical flyback circuit topology so as to form a simple AC/DC transformer. The startup circuit inside IC is designed as a particular current inhalation way, so it can start up with the magnification function of the power switch tube itself, which lessens the power consumption for starting the resistance remarkably; when the output power is lower, IC will reduce the working frequency automatically, therefore, the standby power consumption becomes extremely low. When the power tube is closed, the interior circuit will bias it reversely, utilize the characteristic of high pressure resistance CB of bipolar transistor directly, and improve its pressure resistance capacity to the high voltage of 700V, which ensures the security of the power tube.

Meanwhile, the perfect function of overload and saturation prevention is provided inside of IC, which can keep away some abnormal status, such as overload, saturation of transformer, and output short circuit, so as to improve the reliability of the power supply. The current limit and clock frequency can be set up by exterior components.

Now the standard encapsulation and the environmental protection leadless encapsulation that meets European standard of DIP8 are supplied.

Features

- Set-in high-voltage power switch tube of 700V and few peripheral components.
- With the modulation of lock pulse width, the testing is according to the pulse limit current.
- With the function of output frequency reduction, the non-output power consumption can be less than 0.1W
- Inner-built ramp and anti-feedback compensation function
- The independent upper-limit current testing controller deals with over-current and over-load of the controller real-timely.
- The period emission pole is turned off and it outputs by deflected voltage, and the pressure resistance of the power tube is improved.
- Set-in current limit resistance with temperature compensation, which makes the current limit precise
- Set-in heat protection circuit
- Startup is accomplished with the magnification function of the switch power tube, and the power consumption of startup resistance is reduced more than 10 times.
- Low startup and operating current
- VCC over-voltage automatic limit
- Continuous wide-voltage output power reaches 12W, and the output power of peak value arrives at 18W.

Typical Application

- Adaptor (for example, travel charger, out power station)
- Open Frame (for example, DVD, DVB)

Pin Assignment

Pin Number	Symbol	Function
1	OB	Base electrode of power tube, control terminal of start-up current, external startup resistance.
2	V _{CC}	Power Supply Pin.
3	GND	Ground.
4	CT	Oscillate capacitance pins, external timing capacitance.
5	FB	Feedback pins.
6	IS	Switching current sampling and limit enactment, sampling resistance of external current.
7, 8	OC	Output pins, meet switching transformer.

Note: During PCB layout, the security distance should be kept more than 1mm between Pin6 and Pin7, so as to avoid discharging.

Absolute Maximum Ratings

Parameter	Ratings	Unit
Power supply voltage, V _{CC}	16	V
Pins input voltage	V _{CC} +0.3	V
Endurance voltage of OC collector	-0.3-700	V
Switching current of peak value	800	mA
Continuous Total Power Dissipation	1000	mW
Operating Ambient Temperature	0~+125	°C
Storage Temperature	-55~+150	°C
Soldering temperature and time	+260 (Recommended 10S)	°C

Recommended working condition

Parameter	Min	Typ.	Max	Unit
Power supply voltage, VCC	3.8	5.5	9.0	V
Pins input voltage	-0.3	-	VCC	V
Reverse voltage of peak value	-	-	550	V
Switching current of peak value	-	-	600	mA
Timing capacitance	650	680	920	PF
Oscillating frequency	45	60	65	KHz
Operating temperature	0	-	100	°C

Block Diagram

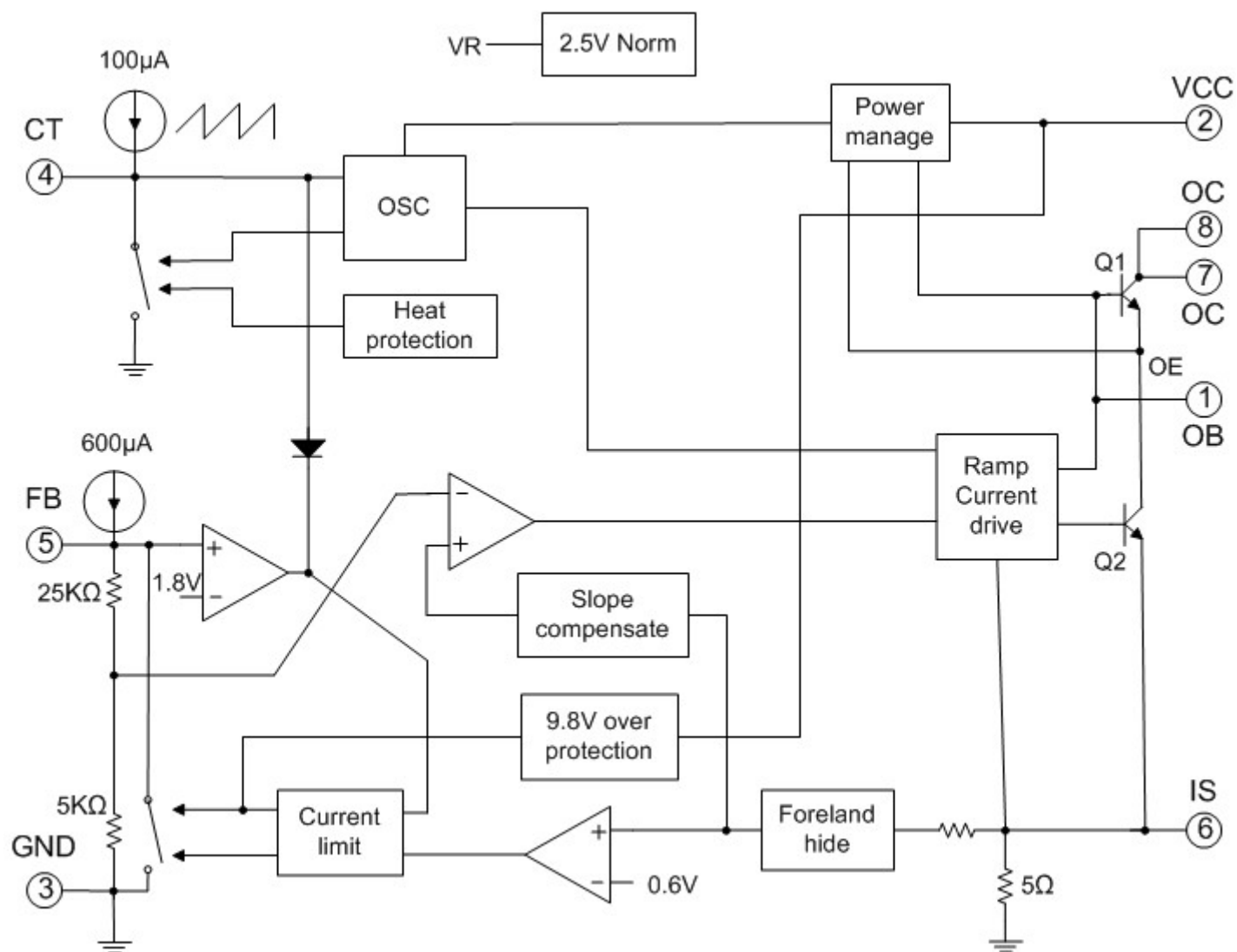

Electrical Characteristics (Ta=25°C, VCC=5.5-7.5V, Ct=680PF, Rs=1Ω)

Item	Testing condition	Min	Typ.	Max	Unit
Output					
Maximum pressure resistance of switching tube	Ioc=1mA	700	-	-	V
on-saturation pressure drop	Ioc=600mA	-	-	1	V
Output rise-time	CL=1nF	-	-	75	ns
Output fall-time	CL=1nF	-	-	75	ns
Output limit current	Tj=0-100°C	540	580	620	mA
OE clamp voltage	OE=0.001-0.60A	-	1.5	-	V
Reference					
Reference output voltage	Io=1.0mA	2.4	2.5	2.6	V
power adjustment ratio	VCC=5.5-9V	-	2	20	mV
Load adjustment ratio	Io=0.1mA-1.2mA	-	-	1	%
Temperature stability		-	0.2	-	mV/°C
Output noise voltage	F=10Hz-10KHz	-	-	50	μV
Long-term stability	Operate 1000h under the condition of T=85°C	-	5	-	mV
Oscillator					
Oscillating frequency	Ct=680PF	-	60	-	KHz
Frequency change ratio with voltage	VCC=5.5-9V	-	-	1	%
Frequency change rate with temperature	Ta=0-85°C	-	-	1	%
Vibration amplitude of oscillator(Vp-p)		-	2.5	-	V
Drop edge of oscillator	Ct=680PF	-	800	-	nS
Feedback					
Input impedance	Pull-up current	-	0.65	0.75	mA
	pull-down resistance	-	30	-	KΩ
Power supply rejection ratio	VCC=5.5V-9V	-	60	70	dB
Current sampling					
Current sampling limit		0.54	0.58	0.62	V
upper limit current prevention	Rs=1Ω	0.54	0.58	0.62	A
Power supply rejection ratio		-	60	70	dB
transmission delay		-	150	250	ns
Modulation of pulse width					
Maximum duty cycle		53	57	61	%
Minimum duty cycle		-	-	3.5	%

Item	Testing condition	Min	Typ.	Max	Unit
Power current					
Startup acceptance current		1.6	2.1	2.4	mA
Startup static current		-	55	80	μA
Static current	VCC=8V	-	3.5	-	mA
Startup voltage		8.8	9.2	9.5	V
Restart voltage		-	3.5	-	V
Over-voltage limit margin		9.5	9.7	9.9	V

Definition of Electric Parameter

- Start-up acceptance current: the current on OC when OB inputs 0.5mA during the start-up phase.
- Start-up Quiescent Current: the current of minimum current source that can make VCC oscillate when VCC meets filter capacitance and adjustable current source, CT meets 680PF, and other pins hang in the air.
- Start-up Voltage: Maximum VCC value of above VCC oscillation.
- Re-start Voltage: Minimum VCC value of above VCC oscillation.
- Close Voltage of Oscillator: VCC value that makes RC oscillator stop oscillating when the above V_{CC} oscillates the falling edge.
- Quiescent Current: VCC power current when FB is grounded with 1.0KΩ of resistance at normal phase.
- Pull-up/pull-down Current of the Oscillator: at normal phase, FB is 2.5V, CT is 1.25V, and CT is in pull-up/pull-down current.
- FB Pull-up Current: Pull-up current on FB at normal phase when FB is 2.5V, IS is 0V.
- FB Upper Limit Current Prevention: The pull-down current on FB at normal phase when FB is 6V, IS is 0.3V.
- Internal Feedback Power Voltage: VCC value of ME8105 power supply of the circuit without peripheral standby at normal phase.
- OC Upper Limit Voltage: the minimum OC current of pull-down current on FB when FB is 6V.
- Ramp current drive: it refers to the power tube base drive OB on-current is the function of I_S, when I_S is 0V, on-current OB is about 40mA, then on-current OB will increase linearly with I_S, when I_S is increased to 0.6V, on-current OE is about 120mA.

Description of the Principle

During start-up phase, V_{ref} is closed when electrified; FB pull-up power source is closed, the start-up current is input from power tube to V_{CC} through OE; OB controls the base current of power tube and limits the current of power tube collector (namely, ME8105 starts the acceptance current), accordingly, the security of the power tube is ensured; when VCC voltage goes up to 8.8V, the start-up phase is ended, and it comes into the normal phase.

During normal phase, V_{CC} voltage shall keep at 3.8~9.0V, VR outputs 2.5V benchmark; FB pull-up current source starts up; the oscillator output OSC1 decides the maximum duty cycle, output OSC2 tries to touch off the power supply to enter open cycle to enter the open cycle, and shield flashing peak current of the power tube ; if FB is less than 1.8V (about between 1.2-1.8V), the cycle of the oscillator will increase with it, the less FB is, the wider the

cycle of the oscillator is, until the oscillation stops (This characteristic reduces the standby power consumption of the switching power.); if the peripheral feedback tries to make VCC more than 9.7V, the in-circuit is fed back to FB and makes VCC stabilize the voltage at 9.7V (According to this characteristic, we can may not adopt peripheral feedback circuit, and stabilize the output voltage by in-circuit, but the precision of stabilizing voltage is low); During the open cycle, OB supplies base current for the power tube, OE pulls down the emitter of the power tube to IS, and OB adopts the driving parameter of ramp current (it refers to that OB on-current is the parameter of IS, when I_S is 0V, OB on-current is about 40mA, then OB on-current increases linearly with IS, when IS increases to 0.6V, OB on-current is about 120mA, this characteristic makes effective use of the output current of OB, decreases the power consumption of ME8105), if IS detects that the specified current FB, it will come into the close cycle; during the close cycle, OB pulls down, the power tube will not shut off immediately, but OE clamps 1.5V (after the power tube is shut off, the base will be biased reversely, which improves the voltage endurance); during open or close cycle, if the power tube is detected beyond the upper limit current, the trigger of the upper limit current will be placed preferentially and forces FB to drop, the duty cycle will become less so as to protect the power tube and transformer; at the beginning of next close cycle or when FB is less than 1.8V, the trigger of the upper limit current will reset. In addition, ME8105 is installed over heat protection internally, when the internal temperature is higher than 140°C, it will broaden the cycle of the oscillator and makes the temperature of ME8105 less than 150°C; The ramp compensation is also placed internally, when ME8105 is in a big duty cycle or in the mode of constant current, it can stabilize the open/close cycle.

If VCC declines to 3.7V or so, ME8105 will come into the start-up phase once again.

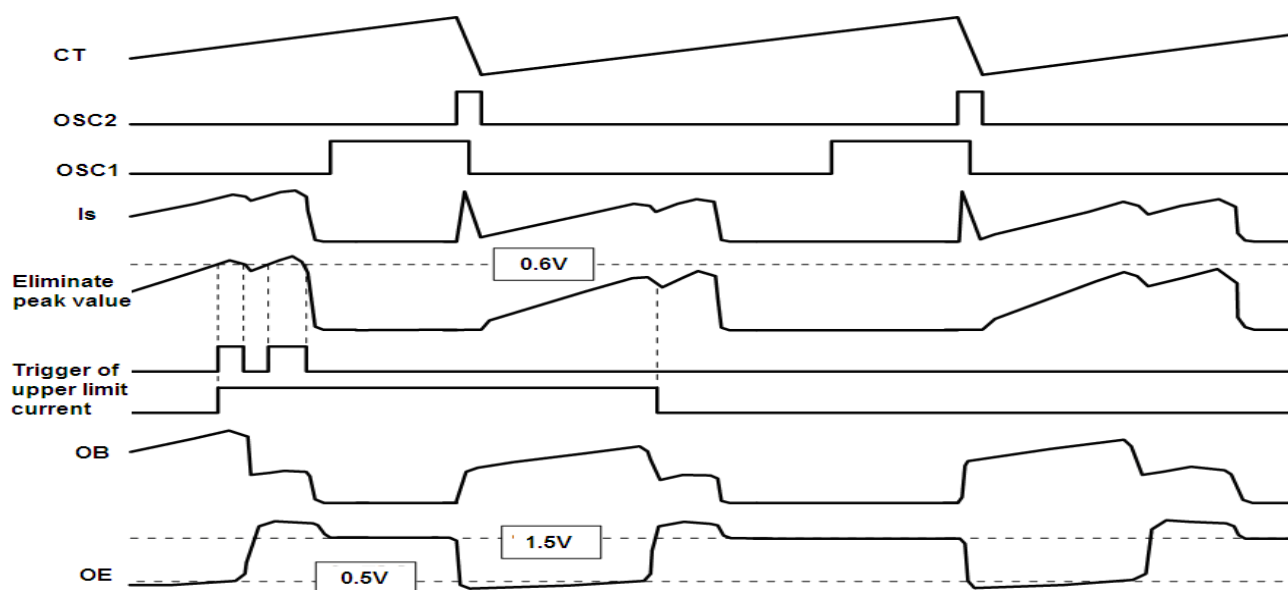

Waveform graph of open and close cycle at normal phase

Application Information

• Relationship between CT timing capacitance and switching frequency

CT capacitance is charged by 100μA constant current through internal current source to for the rise-up edge, when the voltage is charged to 2.5V, the internal circuit will discharge CT with 1.9mA of pull-down current to form the fall-down edge of the clock, and accomplish a clock cycle, which is about: $T=CT*24000$ (s) $Fs=1/T$ (Hz) Although the bipolar circuit can work under higher frequency, but for the switch of bipolar power, the influence caused by switch loss for the storage time is still be considered. Generally, the appropriate switching frequency is about below 70KHz. Under common application situation, CT capacitance of ME8105 can be configured by 680PF, when the relevant working frequency is around 60KHz.

• FB feedback and control

In normal working state, the voltage of FB will decide the value of the maximum switching current, the higher the voltage is, the bigger the switching current is (it is only limited at the peak value). FB pins pull up 600uA power source internally, the pull-down resistance is about 33KΩ (it approximates the equivalent value). In addition, when FB voltage is less than 1.8V, the oscillating cycle will be enlarged, the switching frequency will declined, the more it is less than 1.8V, the lower the switching frequency is. The external FB capacitance will influence the feedback bandwidth, so some external parameters will be affected, such as transient-state characteristic. As for the value of C_{FB} capacitance, the typical application can be selected according to the frequency character of feedback circuit between 10nF and 100nF.(Refer to Fig. 1)

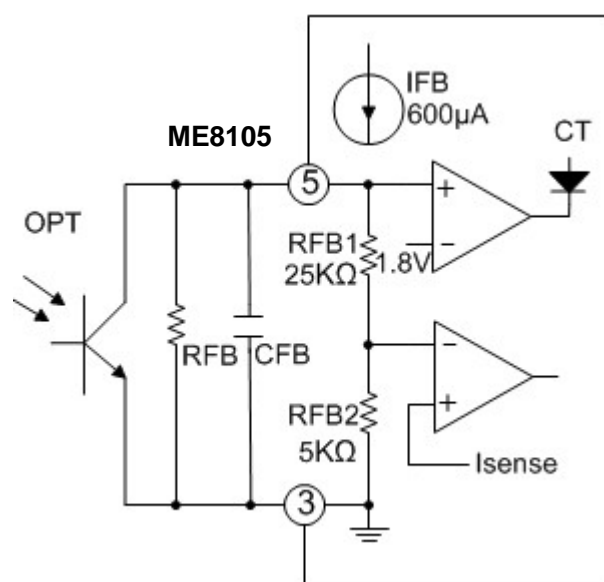

Fig.1

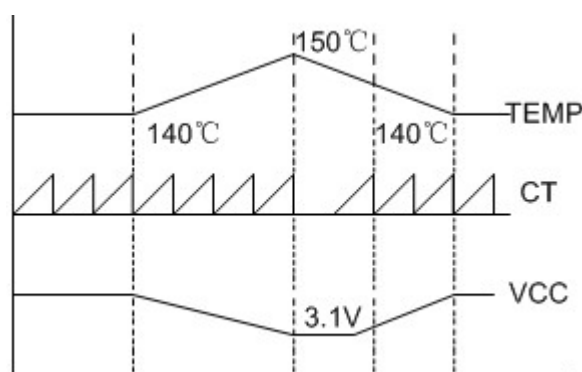

Fig.2

• Over temperature protection

The interior of IC integrates the function of over temperature protection. When the internal temperature of the chip reaches 140°C, the over-heat protection circuit will work, it will pull down the clock signal, the switching frequency will fall until the oscillator is turned off. (As shown Fig.2)

• Driving characteristic and high voltage endurance bias technology of power tube

The power tube adopts the ramp current drive, the driving current will increase with the output power, when FB is 0, the current of OB is about 40mA, when FB is 6V, the current of OB is about 120mA, and the driving power consumption will decrease remarkably when the output is low.

The interior of IC integrates the particular bias technology, when the power tube is shut, the output of OB will be pulled down to the ground, meanwhile, it will bias the output of OE to 1.5V or so, bias the emitter junction, accelerate the decreasing speed of Ic current, expand the effective safe working area, the switching tube affords the reverse voltage CB, therefore, the endurance characteristic of the switching tube can be up to 700V. For more detail information for the voltage endurance characteristic of the switching tube, please refer to the relevant technical data.

Over-voltage and under-voltage protection

IC has the function of slow-moving under-voltage protection, when the voltage of VCC reaches 8.8V, IC will set out to start, the initial start-up voltage is provided by the driving resistance, the high voltage of input will be injected into the base of the switching tube through Ic current, consequently, the driving voltage is formed. When IC works normally, the voltage of VCC should be keep between 3.8V and 9V (including the situation of full load output), when it decreases to 3.8V further, IC will begin to reset. As shown in Fig.3:

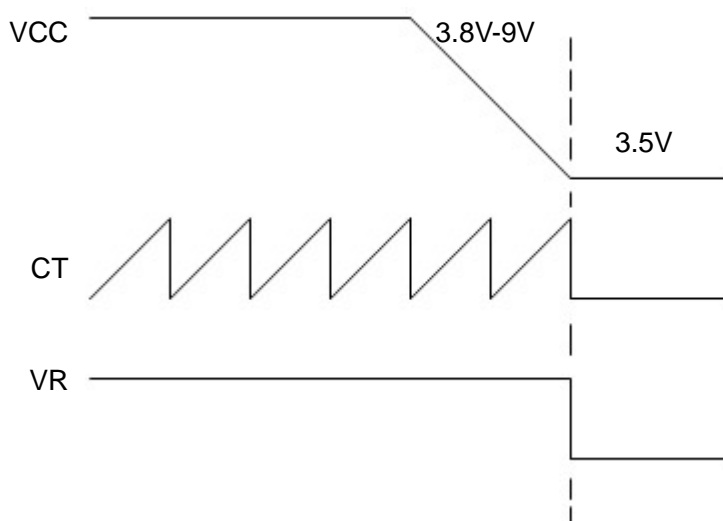

Fig.3

VCC in side IC is provided with a comparator controller of the upper limit voltage, if VCC tries to be more than 9.7V, the comparator will work, FB will be pulled down, and it will lock V_{CC} to 9.7V, and reach the limit function of over voltage, by which the voltage feedback function of the front terminal can be accomplished conveniently, the rising phenomenon of the output voltage in large extent can be avoided when the open-loop is output, so as to guarantee the security of the load. Because of the existence of this characteristic, the design of VCC shall be kept at the proper range, so as to avoid VCC rising excessively high when the output is high, and make the output voltage escape from decreasing when IC over-voltage limit works.

• Maximum switching current limit

IC has the function of current limit cycle by cycle. It will test every switching current in every switching cycle, if the current fixed by FB or upper limit current prevention is reached, it will come into the close cycle, and the detection of the current has the function of real-time foreland hide, it can shield the switching peak, and avoid the wrong detection of the switching current. Then the reasonable temperature compensation eliminates the influence of temperature, comparing with normal MOSFET (the alteration of R_{on} will be large when the temperature changes) switching chip, the switching current can always be very accurate in a larger range, thus not too much allowance is needed to match a larger working temperature range for the designer when he designs the scenario, and the security of the circuit for use can be improved.

The maximum limit value of switching current for ME8105 is 0.80A. When designing a flyback power with 65V of emitter voltage and 0.8A of switching current, it can accomplish the output power of more than 12W easily, and meet the broad temperature range.

Requirement of heat elimination

As for a typical power switch, it must have necessary heat elimination measures, so as to avoid that the excessive heat leads to heat protection. The primary heat inside IC is produced by the on-off wasting of the switching tube, so appropriate heat elimination position is Pin7-8 pin of IC, one wiely way is to pave PCB copper foil of a certain area on Pin7-8 pin, what's more, plating tin on the copper foil will improve the heat elimination ability greatly.

For an input of 85-265V, the typical application of 12W output and 200mm² copper foil are necessary. Reference wiring is as Fig.4:

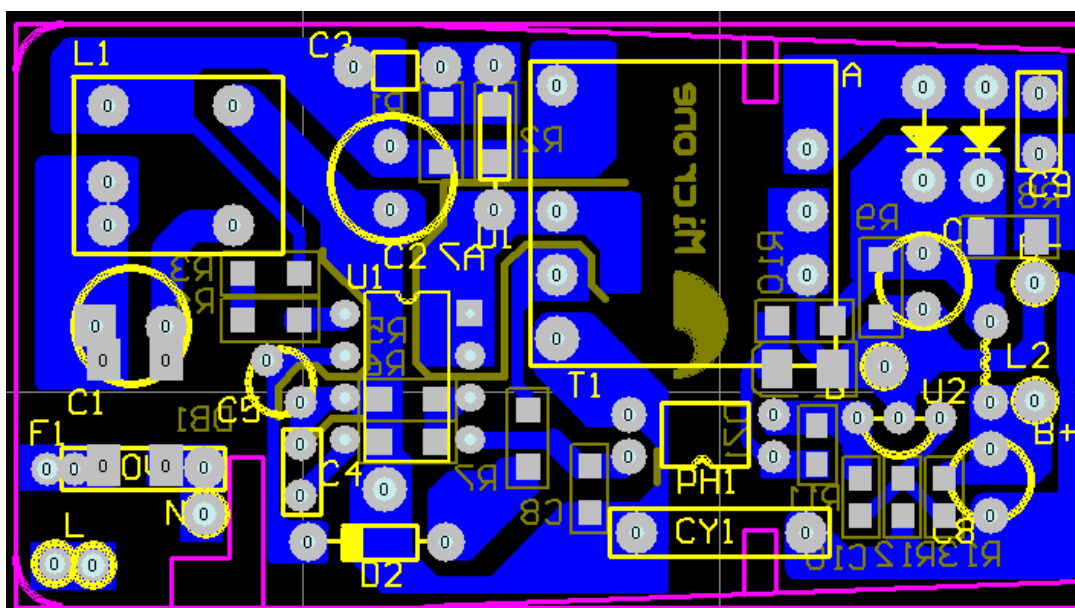
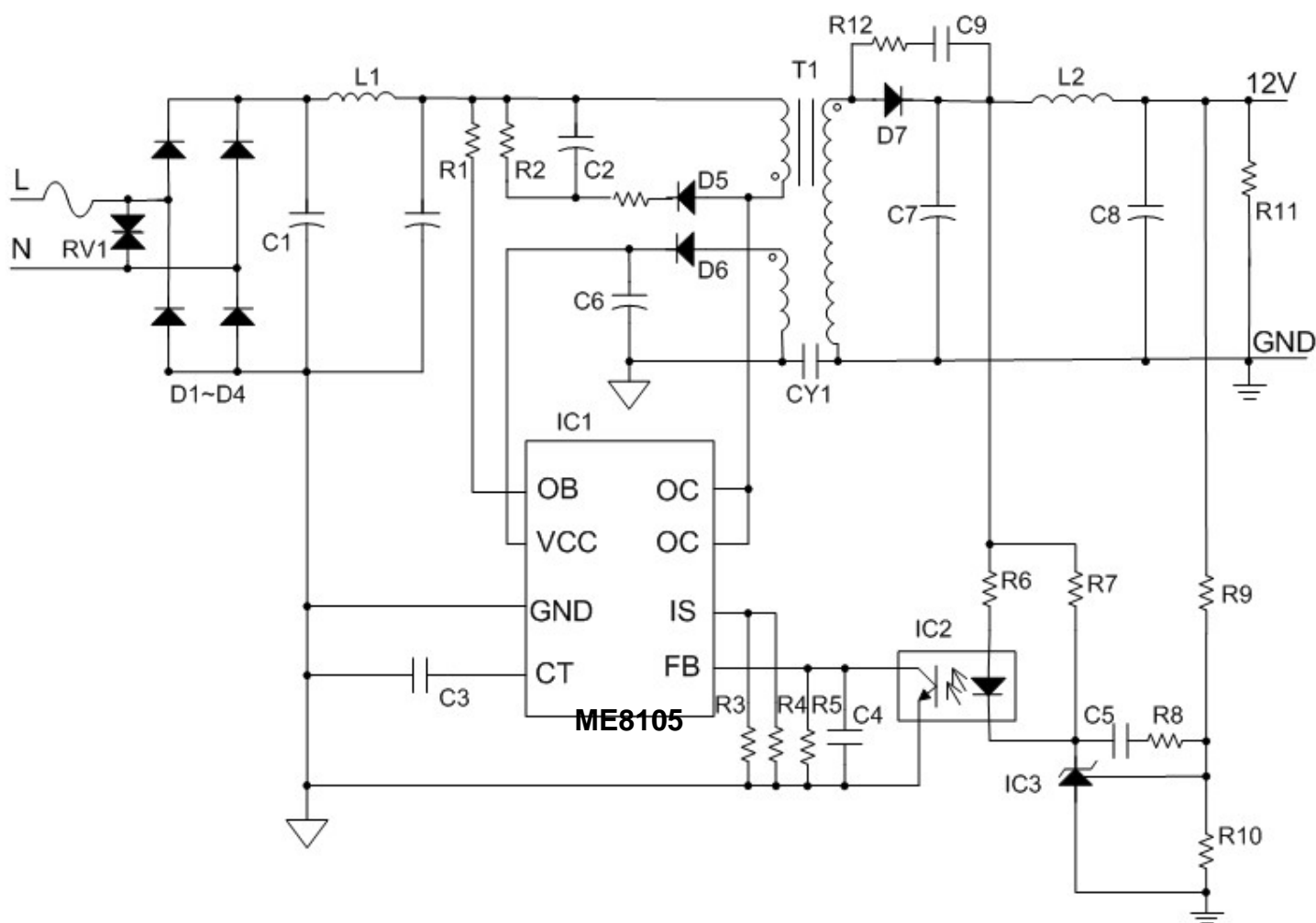

Fig.4

Typical application circuit(input 90-240V, output 12V 1A)



Primary waveform of testing point

1.Vce waveform diagram

Vin=85V, Io=0.5A

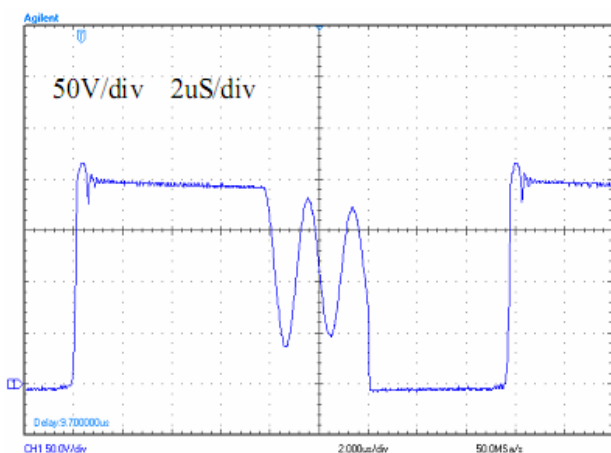

Vin=110V, Io=0.5A

Vin=85V, Io=1A

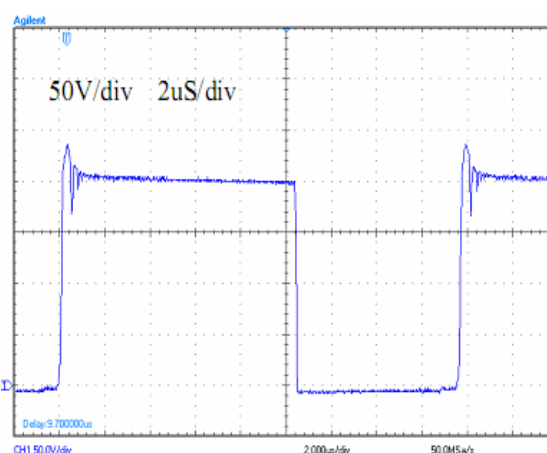

Vin=110V, Io=1A

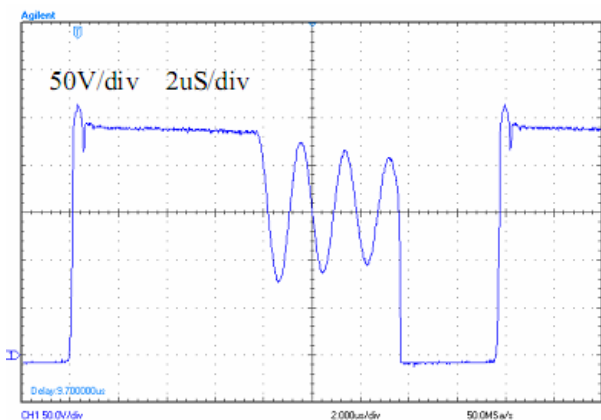

Vin=220V, Io=0.5A

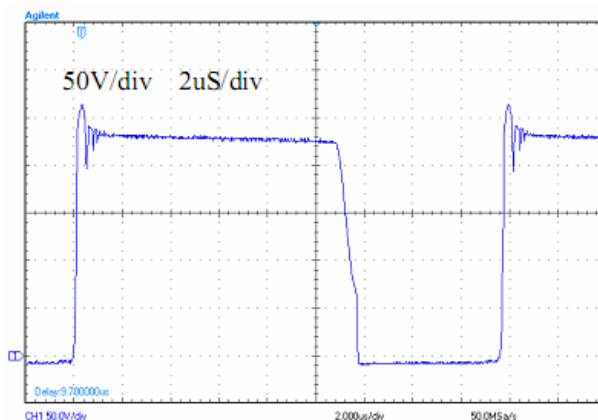

Vin=220V, Io=1A

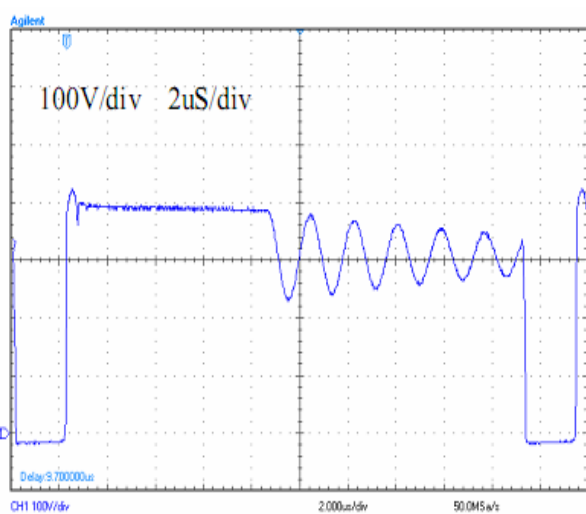

Vin=265V, Io=0.5A

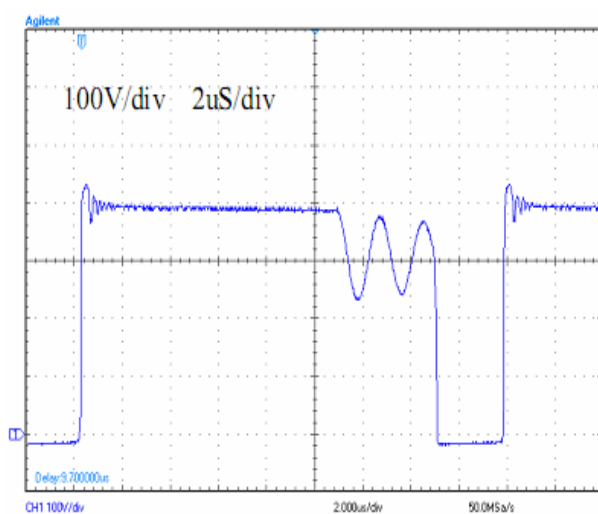

Vin=265V, Io=1A

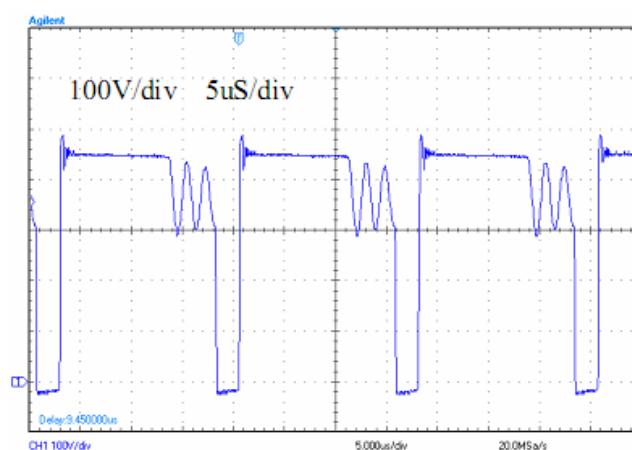
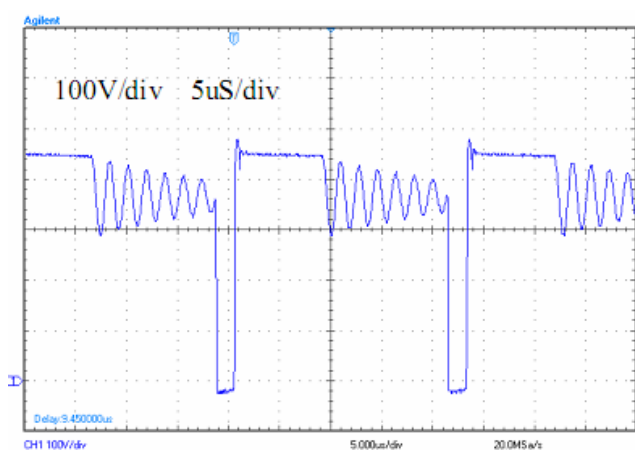

2. Output noise waveform

Vin=85V, Io=1A

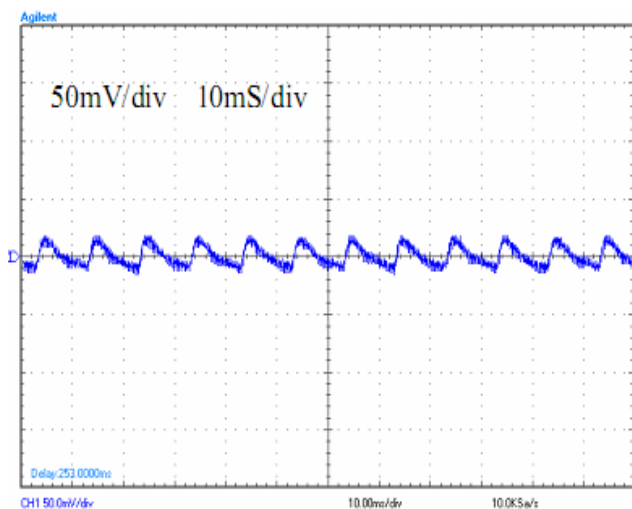

Vin=265V, Io=1A

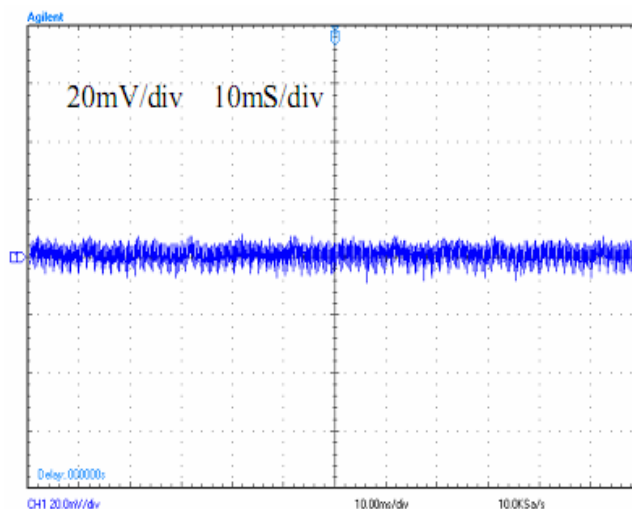

3. Output ripple waveform

Vin=85V, Io=1A

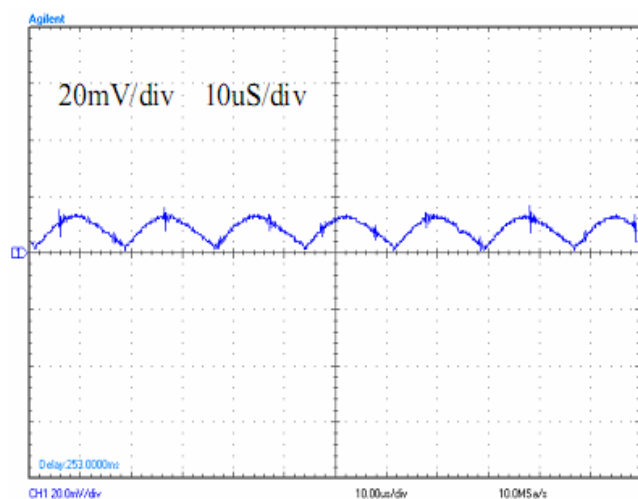

Vin=265V, Io=1A

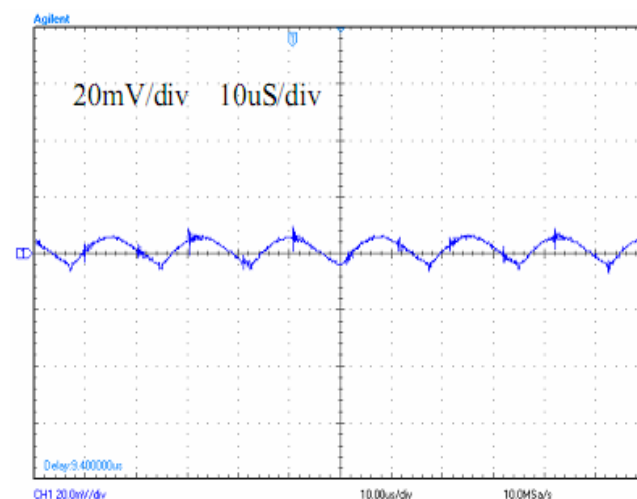

4. Output waveform on start-up

Vin=85V, Io=1A

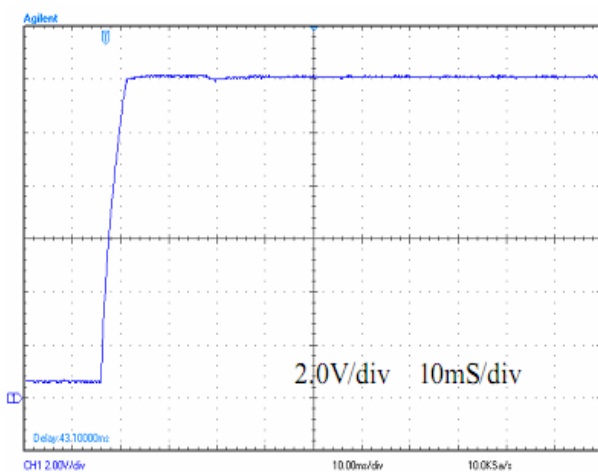

Vin=265V, Io=1A

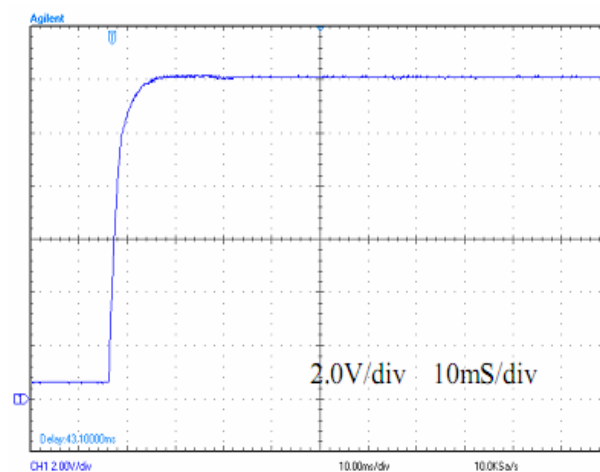

5. Vce and Vo waveform on start-up

Vin=85V, Io=1A

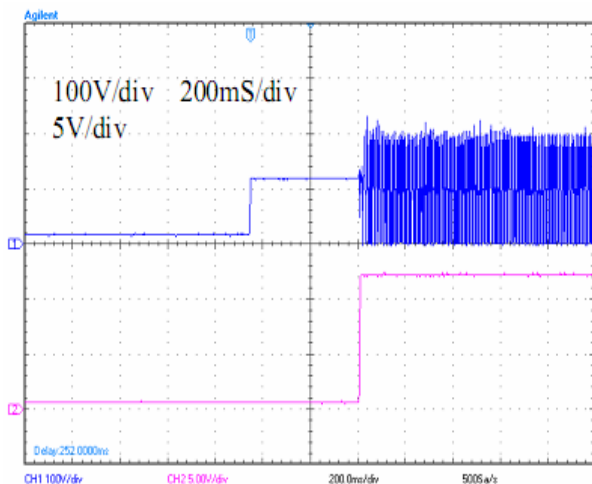

Vin=265V, Io=1A

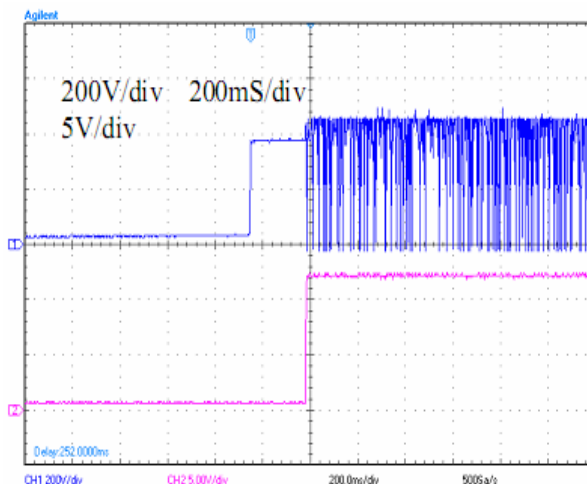

6. Vce waveform when the output suffers short circuit

Vin=85V, Io=Short

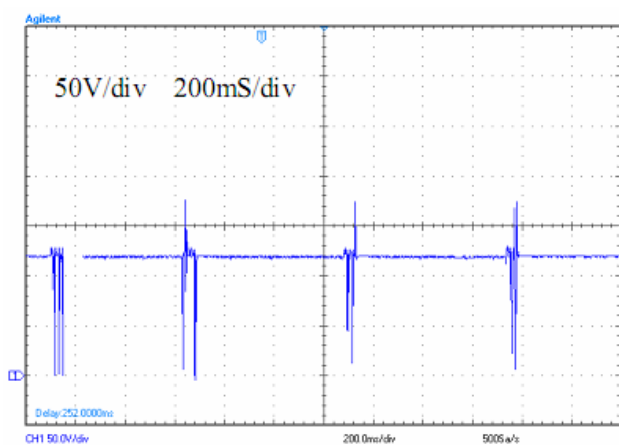

Vin=265V, Io=Short

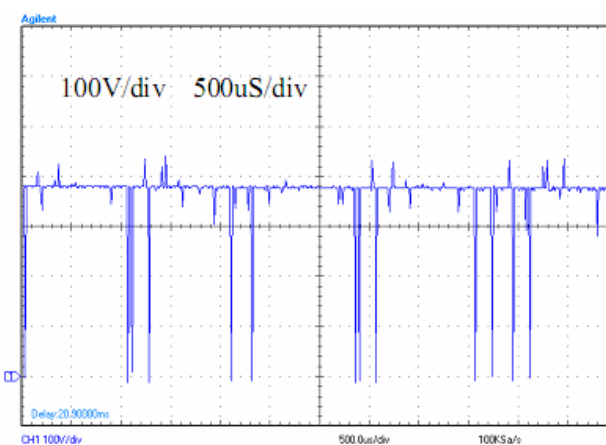

7. Diagram of Switch efficiency and input power consumption:

Efficiency curve under various conditions of input and output

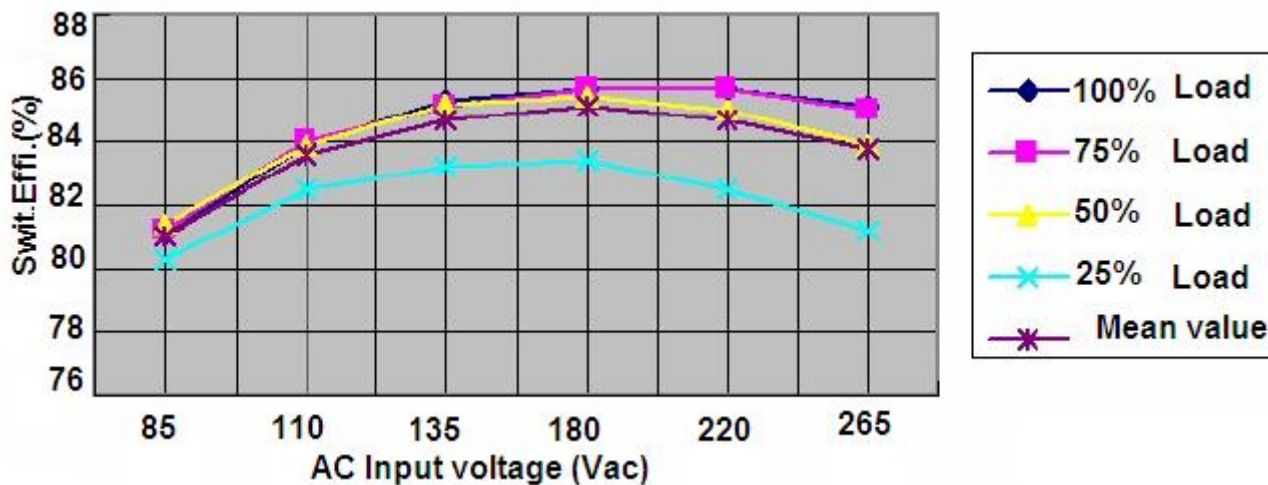

Input power curve during non-load

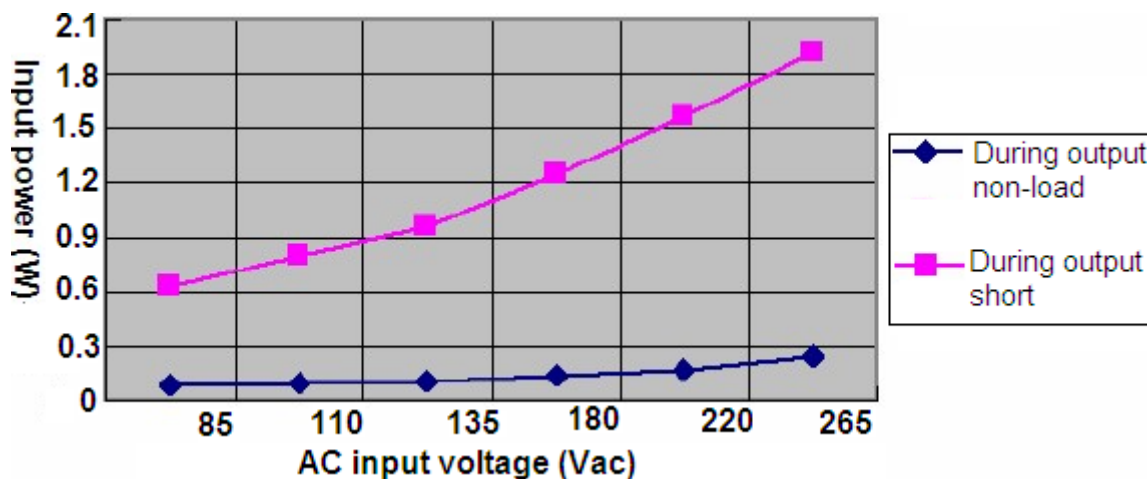

Package Information

- DIP8 Unit: mm (inch)

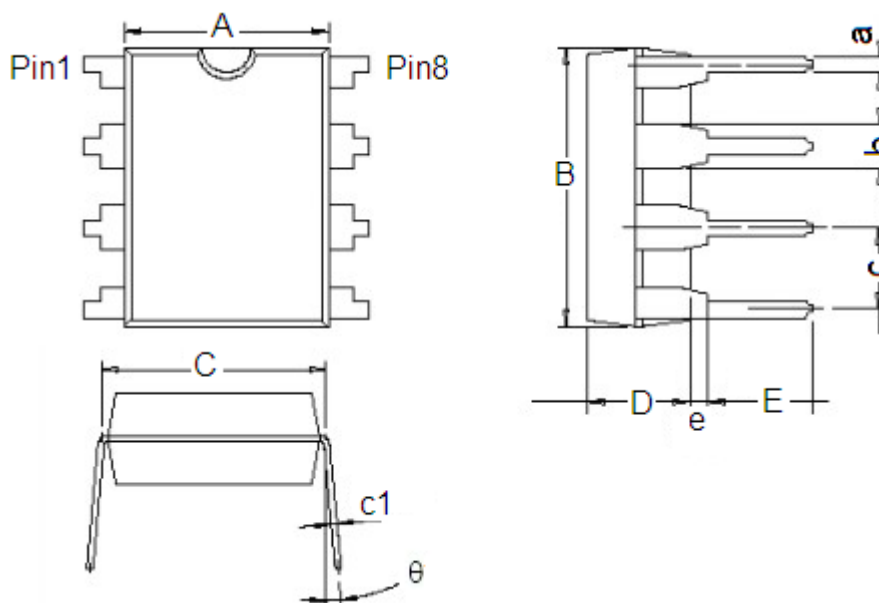

Character	Dimension (mm)		Dimension (Inches)	
	Min	Max	Min	Max
A	6.200	6.600	0.244	0.260
B	9.000	9.400	0.354	0.370
C	7.620(Typ.)		0.300(Typ.)	
D	3.200	3.600	0.126	0.142
E	3.000	3.600	0.118	0.142
a	0.360	0.560	0.014	0.022
b	1.524(Typ.)		0.060(Typ.)	
c	2.54(Typ.)		0.100(Typ.)	
c1	0.204	0.360	0.008	0.014
e	0.510(Min)		0.020(Min)	
θ	0°	15°	0°	15°

- The information described herein is subject to change without notice.
- Nanjing Micro One Electronics Inc is not responsible for any problems caused by circuits or diagrams described herein whose related industrial properties, patents, or other rights belong to third parties. The application circuit examples explain typical applications of the products, and do not guarantee the success of any specific mass-production design.
- Use of the information described herein for other purposes and/or reproduction or copying without the express permission of Nanjing Micro One Electronics Inc is strictly prohibited.
- The products described herein cannot be used as part of any device or equipment affecting the human body, such as exercise equipment, medical equipment, security systems, gas equipment, or any apparatus installed in airplanes and other vehicles, without prior written permission of Nanjing Micro One Electronics Inc.
- Although Nanjing Micro One Electronics Inc exerts the greatest possible effort to ensure high quality and reliability, the failure or malfunction of semiconductor products may occur. The user of these products should therefore give thorough consideration to safety design, including redundancy, fire-prevention measures, and malfunction prevention, to prevent any accidents, fires, or community damage that may ensue.