

### DESCRIPTION

MEL78 is NPN silicon planar photo-transistor. It features ultra high illumination sensitivity, fast response time.

MEL78 is spectrally and mechanically matched with MI31T or MIB31T.

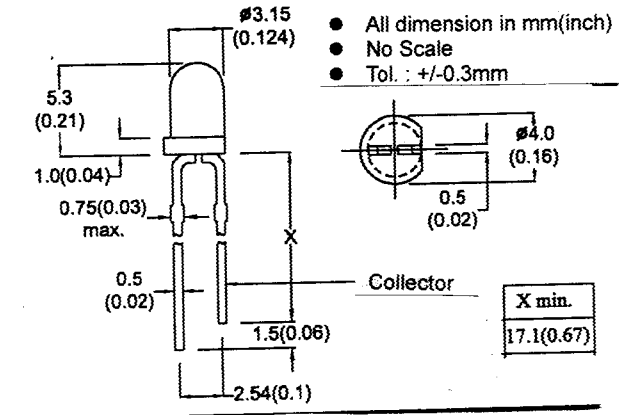

### ABSOLUTE MAXIMUM RATINGS

Collector-Emitter Voltage	V <sub>CEO</sub>	30V
Emitter-Collector Voltage	V <sub>ECO</sub>	5V
Continuous Power Dissipation	P <sub>d</sub>	50mW
Operating Junction Temperature	T <sub>j</sub>	-40 to +85°C
Storage Temperature Range	T <sub>stg</sub>	-40 to +100°C
Lead Soldering Temperature (5 sec., 1/16" from body)		260°C

### ELECTRO-OPTICAL CHARACTERISTICS (T<sub>a</sub>=25°C)

PARAMETER	SYMBOL	MIN	TYP	MAX	UNIT	CONDITIONS
Collector-Emitter Breakdown Voltage	V <sub>CEO</sub>	30			V	I <sub>C</sub> =100μA E <sub>e</sub> =0
Emitter-Collector Breakdown Voltage	V <sub>ECO</sub>	5			V	I <sub>C</sub> =100μA E <sub>e</sub> =0
Dark Current	I <sub>D</sub>			100	nA	V <sub>CE</sub> =10V E <sub>e</sub> =0
Light Current	I <sub>L</sub> *	6	10		mA	V <sub>CE</sub> =5V E <sub>e</sub> =5mW/cm <sup>2</sup>
Collector-Emitter Saturation Voltage	V <sub>CE(sat)</sub>			0.3	V	I <sub>C</sub> =2mA I <sub>B</sub> =100μA
Rise Time	T <sub>r</sub>		15		μs	V <sub>cc</sub> =5V I <sub>C</sub> =1mA R <sub>L</sub> =1KΩ
Fall Time	T <sub>f</sub>		15		μs	V <sub>cc</sub> =5V I <sub>C</sub> =1mA R <sub>L</sub> =1KΩ



MICRO ELECTRONICS LTD.

38, Hung To Road, Microtron Building, Kwun Tong, Kowloon, Hong Kong.

Kwun Tong P.O. Box 69477 Hong Kong. Fax No. 2341 0321 Telex: 43510 Micro Hx. Tel: 2343 0181-5