

2.7Gbps Multi-Rate CWDM SFP Transceiver with Digital Diagnostic Monitoring Interface **MF-27WXD Series**

1. Description

This transceiver is compliant with Small Form-factor Pluggable (SFP) MSA, and optimized for 155Mbps to 2.7Gbps Coarse Wavelength Division Multiplexing (CWDM) applications.

The optical subassembly consists of two parts, the transmitter with an uncooled DFB laser in a hermetic sealed coaxial module, the receiver with an APD preamp in a hermetic sealed coaxial module and integrated circuits for reshaping received optical signals.

The built-in serial ID recognition is incorporated, which allows users to interface with two wire serial interface that displays information on manufacturer, part number, link, distance, and other parameters.

The Digital Diagnostic Monitoring interface is incorporated, which monitors transceiver parameters including Temperature, Supply voltage, Laser bias current, Laser power and Received optical power.



2. Features

- Small Form-factor Pluggable (SFP) MSA compliant transceiver with SONET/SDH system Quality
- **Full 8 wavelength line-up for CWDM grid**
- **155Mbps to 2.7Gbps** Multi-Rate operation capability
- LC duplex receptacle
- Single +3.3V power supply
- Differential data inputs and outputs
- Operating case temperature range 0°C to +70°C
- Comply with SFF-8472 MSA
- **Built-in Programmable receiver low pass filter** as application select
- Incorporating Digital Diagnostic Monitoring Interface with External calibration (Internal calibration is optional)
- Serial ID Functionality
- APD receiver
- Bail latch type
- RoHS Compliant

3. Block diagram

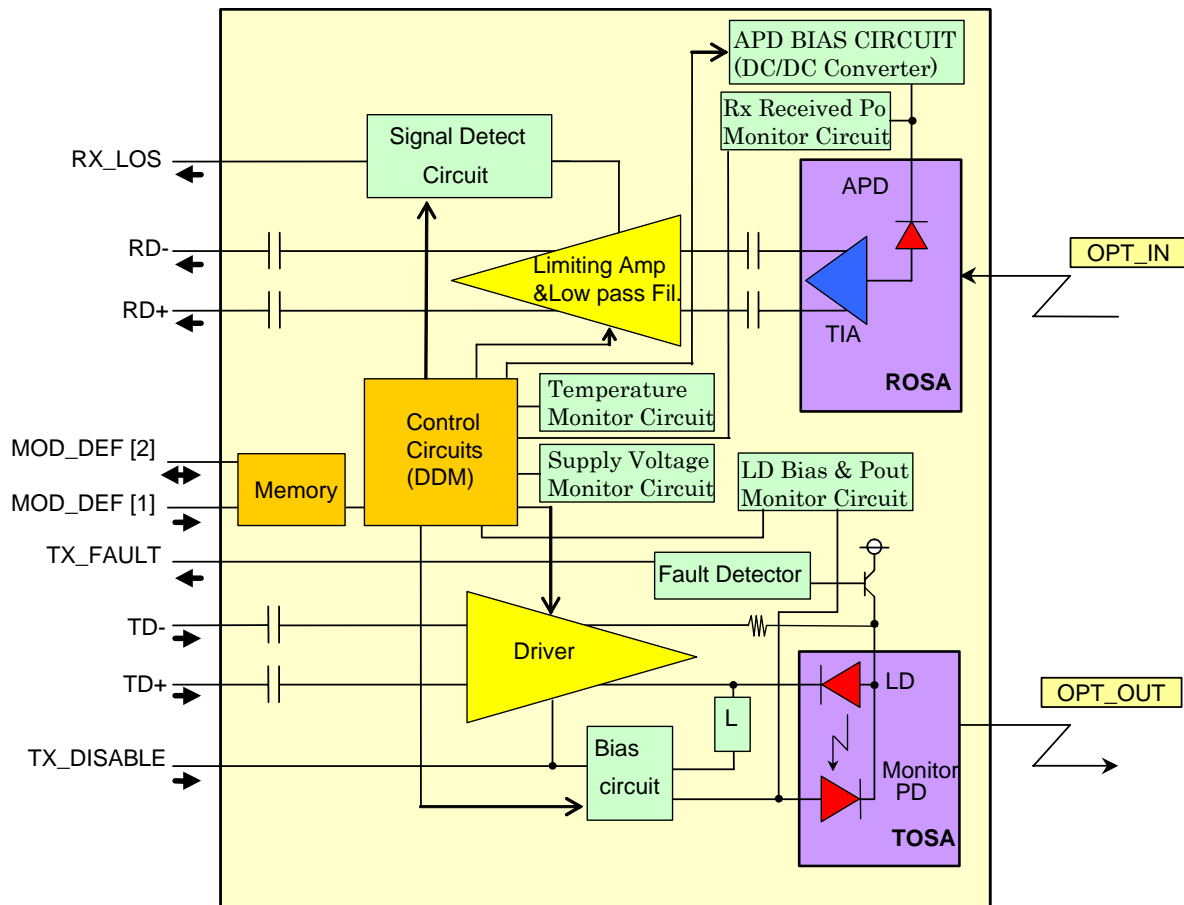

4. Absolute Maximum Ratings

Stress below listed absolute maximum rating may cause permanent damage to the module. This is a stress only and functional operation of the module at these or any other conditions in excess of those given in the operational sections of this data sheet. Exposure to Absolute Maximum Rating for extended periods may affect module reliability.

Parameters	Symbol	Ratings	Unit
Supply voltage	Vcc	0 to +4.0	V
Storage temperature	Tstg	-40 to +85	°C
Operating case temperature	Tc	0 to +70	°C
Relative humidity (non condensation)	-	5 to 85	%

5. Electrical characteristics

All parameters are specified over the operating case temperature.

Measurement conditions are at 2.48832Gbps +/-20ppm, NRZ PN²³-1 and 50% duty cycle data signal.

The DATA input/output signal interface is AC-coupled internally.

TX_DISABLE input signal level is LVTTTL compatible. (With internally pull-up 4.7k to 10k Ω)

TX_FAULT and LOS (Loss Of Signal) output are Open-Collector/drain, and the levels indicated assuming 4.7k to 10k ohm pull up resistor to Host_Vcc is present.

Parameters	Symbol	Min.	Typ.	Max.	Unit
Supply voltage	V _{CC}	3.13	3.3	3.47	V
Power consumption	P _C	-	0.8	1.2	W
TX_DISABLE Input voltage	V _{IH}	2.0	-	V _{CC}	V
	V _{IL}	0	-	0.8	V
TX_FAULT Output voltage	V _{OH}	2.0	-	V _{CC}	V
	V _{OL}	0	-	0.5	V
RX_LOS Output voltage	V _{OH}	2.0	-	V _{CC}	V
	V _{OL}	0	-	0.5	V
MOD_DEF[2] Output voltage	V _{OH}	V _{CC} × 0.8	-	V _{CC}	V
	V _{OL}	0	-	0.4	V
MOD_DEF[1], [2] Input voltage	V _{IH}	V _{CC} × 0.7	-	V _{CC}	V
	V _{IL}	0	-	V _{CC} × 0.3	V
Input Amplitude, Differential	V _T	500	-	2400	mV _{P-P}
Input Impedance, Differential	R _T	-	100	-	Ω
Output Amplitude, Differential	V _O	370	-	1600	mV _{P-P}
Output Impedance, Differential	R _O	-	100	-	Ω
Data Output Rise/Fall Time (20% to 80%)	Tr/Tf	-	-	150	ps
Electrical Input Data Return Loss 100MHz < f < 1.2GHz(Differential)	Rld1	12	-	-	dB
Electrical Input Data Return Loss 1.2GHz < f < 2.7GHz(Differential)	Rld2	8	-	-	dB

6. Optical characteristics

All parameters are specified over the operating case temperature.
 Measurement conditions are at 2.48832Gbps +/-20ppm, NRZ PN2²³-1 and 50% duty cycle data signal.

Transmitter			
Parameter	Min.	Max.	Unit
Target Distance	-	80	Km
Wavelength	note 1		nm
Optical source	SLM		-
Optical power BOL (3.3V, 25degC)	+1	+5	dBm
Optical power EOL	0	+5	dBm
Optical power when disable	-	-40	dBm
Spectral width (-20dB)	-	1.0	nm
SMSR	30	-	dB
Extinction ratio	8.2	12	dB
Optical waveform	SONET/SDH Mask compliant		-
Return Loss at S	24	-	dB
Path penalty (note 2)	-	2	dB
Jitter Generation (note 3) -Bandwidth 12KHz to 20MHz	-	0.01	UIrms
Jitter Generation (note 3) -Bandwidth 12KHz to 20MHz	-	0.1	UIpp

note 1: The wavelength range is -5.5 to +7.5 nm from each center wavelength.

Min.	Typ.	Max.	Unit
1604.5	1610	1617.5	nm
1584.5	1590	1597.5	
1564.5	1570	1577.5	
1544.5	1550	1557.5	
1524.5	1530	1537.5	
1504.5	1510	1517.5	
1484.5	1490	1497.5	
1464.5	1470	1477.5	

note 2: Support 80km of normal single-mode fiber.

Chromatic Dispersion is required by each wavelength.

Wavelength	Chromatic Dispersion	Unit
1610nm	1600	ps/nm
1590nm	1600	
1570nm	1500	
1550nm	1400	
1530nm	1400	
1510nm	1300	
1490nm	1200	
1470nm	1100	

MITSUBISHI (OPTICAL DEVICES)
MF-27WXD Series
2.5Gbps SFP TRANSCEIVER MODULE

note 3: Jitter Generation (ITU-T G.783 compliant)

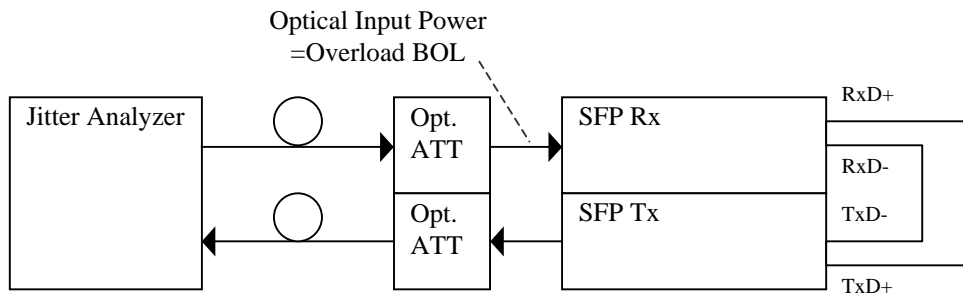

Receiver			
Parameter	Min.	Max.	Unit
Wavelength	1460	1620	nm
Sensitivity BOL (3.3V, 25degC, BER=1E-10)	-	-29	dBm
Sensitivity EOL (BER=1E-10)	-	-28	dBm
Overload BOL (3.3V, 25degC)	-7	-	dBm
Overload EOL	-8	-	dBm
RX_LOS Assert Level	-39	-	dBm
RX_LOS De-assert Level	-	-29	dBm
RX_LOS Hysteresis	0.3	4.0	dB
CID Penalty (note 1)	-	1.0	dB
Jitter Tolerance, Transfer	ITU-T G.783 Compliant (with reference CDR)		-
Maximum reflectance of receiver at R	-	-27	dB

note 1: Penalty between PRBS 2E23-1 and Consecutive Identical Digits according to ITU-T G957

7. Digital Diagnostic Monitoring Accuracy

The diagnostic monitoring features external calibration, and is calibrated over operating temperature and voltage range. The monitor parameters are represented as defined in SFF-8472.

These parameters of the monitoring accuracy are guaranteed, as long as operating conditions of this SFP transceiver do not exceed ranges defined below.

Digital Diagnostic Monitoring Accuracy				
Parameter	Min.	Max.	Unit	Range for Accurate Monitoring
Transceiver Temperature*1	-3	+3	°C	0 to 70°C
Supply Voltage	-3	+3	%	3 to 3.6 V
TX Bias Current	-10	+10	%	-
TX Optical Power	-3(-1.5* ²)	+3(+1.5* ²)	dB	0 to 5 dBm
RX Optical Power	-3(-2* ²)	+3(+2* ²)	dB	-29 to -7 dBm

*1: Transceiver Temperature is defined as an internal ambient temperature.

*2: These specs are optional.

8. Selective Bandwidth filtering function

Receiver bandwidth is selected by the Rate Select pins (7pin and 9pin).

Each bit rates for the selective bandwidth and adaptable protocols are as follows.

No.	Rate Select 0 (7pin)	Rate Select 1 (9pin)	Bandwidth	Adaptable protocols
1	Low	Low	Full	STM-16/OC-48, OTN-1
2	High	Low	1.25Gbps	Gigabit Ethernet
3	Low	High	622Mbps	STM-4/OC-12, ESCON
4	High	High	155Mbps	STM-1/OC-3, FDDI

*Optional Bandwidth: 2.125Gbps and 1.062Gbps bandwidth can be selected by the internal setting.

9. Transceiver pin allocation

No.	Symbol	Description	No.	Symbol	Description
1	TX GND	Transmitter Ground	11	RX GND	Receiver Ground
2	TX_FAULT	Transmitter Fault Indication	12	RD-	Receiver Data Output-Bar
3	TX_DISABLE	Transmitter Disable	13	RD+	Receiver Data Output
4	MOD_DEF[2]	Module Definition 2	14	RX GND	Receiver Ground
5	MOD_DEF[1]	Module Definition 1	15	RX Vcc	Receiver Power Supply
6	MOD_DEF[0]	Module Definition 0	16	TX Vcc	Transmitter Power Supply
7	Rate Select 0	Rate Select pin 0	17	TX GND	Transmitter Ground
8	RX_LOS	Loss of Signal	18	TD+	Transmitter Data in
9	Rate Select 1	Rate Select pin 1	19	TD-	Transmitter Data in-Bar
10	RX GND	Receiver Ground	20	TX GND	Transmitter Ground

10. Pin Descriptions

Pin No.	Function	I/O	Pin description
1,17,20	TX GND	I	These pins are the Transmitter ground connections. They should be connected to a low impedance ground plane (0V).
10, 11,14	RX GND	I	These pins are the Receiver ground connections. They should be connected to a low impedance ground plane (0V).
16	TX Vcc *	I	This is the power supply pin for the Transceiver part. It should be connected to +3.3V. Recommended power supply decoupling. (See Figure 8)
15	RX Vcc *	I	This is the power supply pin for the Receiver part. It should be connected to +3.3V. Recommended power supply decoupling. (See Figure 8) * Both TX Vcc and RX Vcc have been internally connected due to supply of control circuit Vcc.
18,19	TD+ / TD-	I	This data input pin modulates the laser diode. When the TD+ input is asserted, the laser diode is turned on. They are internally AC-coupled into an equivalent load of RI differential, as shown in Figure 8.
3	TX_DISABLE	I	Active high TTL input, with internal 7.4k ohm pull-up resistor to Vcc. Asserting the transmitter disable will deactivate the laser within the assert time. Table 1 indicates the timing of TX_DISABLE.
12,13	RD+ / RD-	O	Received Data Out and Inverted Received Data Out are differential serial output from the receiver. These are AC-coupled 100 ohm differential lines which should be terminated with a 100 ohm (differential) at the user SERDES, as shown in Figure 8. AC coupling is done inside the module and is thus not required on the host board.
8	RX_LOS	O	Active high open collector/drain output that indicates a loss-of-signal condition (LOS). When the average optical power received by the module is below the Assert Level, RX_LOS is indicated. Table 1 indicates the timing of RX_LOS. RX_LOS requires a 4.7k to 10k ohm pull-up resistor external to the module, i.e., in the host system Host_Vcc, as shown in Figure 8. The pull-up voltage is between 2.0 V and VccR (VccT) + 0.3 V.
2	TX_FAULT	O	Active high open collector/drain output that indicates a fault in the module. This can be failure of the laser diode. Under this condition, TX_FAULT will activate and be latched. And then the laser will be deactivated within the assert time. TX_FAULT also requires a 4.7k to 10k ohm pull-up resistor externally, i.e. in the host system Host_Vcc, as shown in Figure 8. The pull-up voltage is between 2.0 V and VccT (VccR) +0.3V. Toggling TX_DISABLE high for at least t_reset can reset it. See Figure 8 and Figure 5.
6,5,4	MOD_DEF [0:2]	-	This module has a serial ID function, which provides information about the transceiver's capabilities, standard interfaces, manufacturer and other information. This function is provided via a two wire serial EEPROM interface. MOD_DEF[0] is connected to ground inside the module. (LOW) MOD_DEF[1] is the serial clock signal input. (SCL) MOD_DEF[2] is the data output/input. (SDA) They should be pulled up with 4.7Kohm -10Kohm resistor on the host board. The pull-up voltage shall be VccT or VccR. The serial ID definitions are as given in the "SFP-MSA" standard. See Figure 9.
7,9	Rate Select 0, 1	I	These pins defined the bandwidth filters. 7pin/9pin setting=[*/*]: [0/0]: Full bandwidth, [1/0]: 1.25Gbps, [0/1]: 622Mbps, [1/1]: 155Mbps These input pins are internally pulled down to GND with 33Kohm resistor. If this function is not used, both pins should be left open or connected to GND.

Table 1

Timing of control and status I/O

The timing of the control and status line are listed in below and Figure 1 to 7.

Parameter	Symbol	Min	Max	Unit	Condition
TX_DISABLE Assert Time	t_off	-	10	μs	Time from rising edge of TX_DISABLE to when the optical output falls below 10% of nominal
TX_DISABLE Negate Time	t_on	-	1	ms	Time from falling edge of TX_DISABLE to when the modulated optical output rises above 90% of nominal
Time to Initialize, Including Reset of TX_FAULT	t_init	-	300	ms	From power on or negation of TX_FAULT using TX_DISABLE
TX_FAULT Assert Time	T_fault	-	100	μs	Time from fault to TX_FAULT on
TX_DISABLE to Reset	T_reset	10	-	μs	Time TX_DISABLE must be held high to reset TX_FAULT
RX_LOS Assert Time	t_losson	-	100	μs	Time from LOS state to RX_LOS Assert
RX_LOS Negate Time	t_lossoff	-	100	μs	Time from non-LOS state to RX_LOS de-assert
Serial ID Clock Rate	f_clock	-	100	kHz	-

Figure 1

Power on initialization of SFP transceiver, TX_DISABLE negated

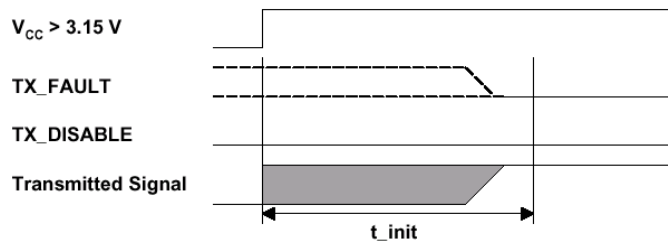

Figure 2

Power on initialization of SFP transceiver, TX_DISABLE asserted

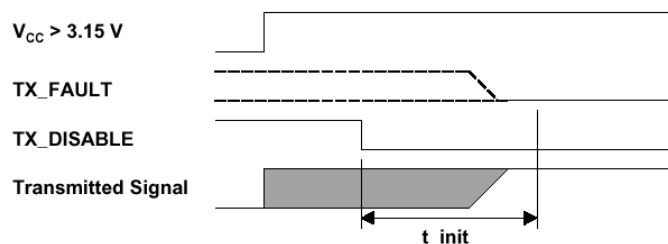

Figure 3

SFP TX_DISABLE timing during normal operation

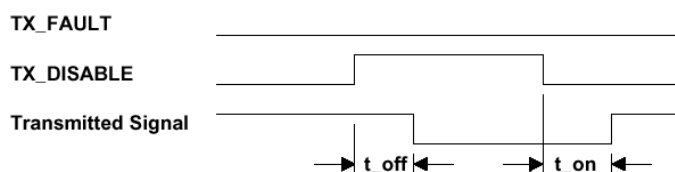

Figure 4
 Detection of transmitter fault condition

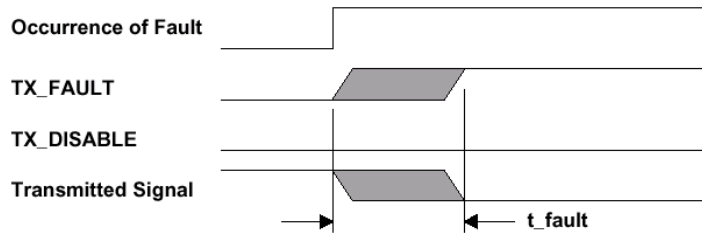

Figure 5
 Successful recovery from transient fault condition

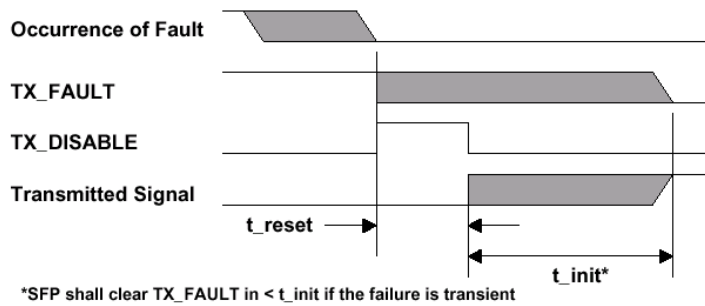

Figure 6
 Unsuccessful recovery from fault condition

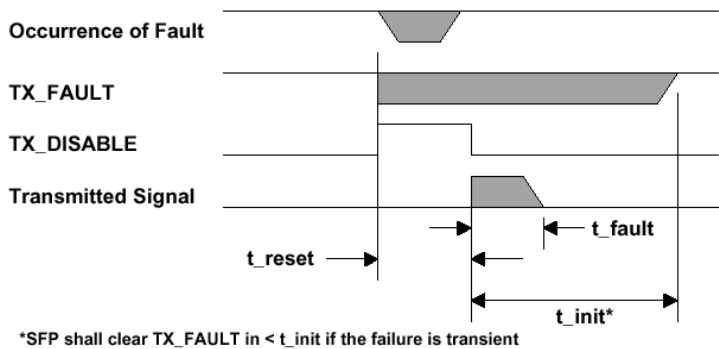

Figure 7
 Timing of RX_LOS detection

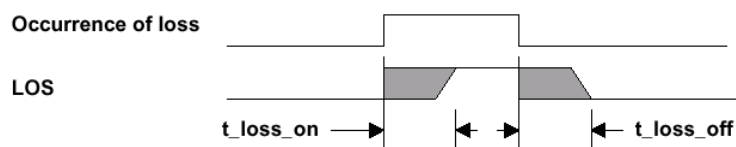
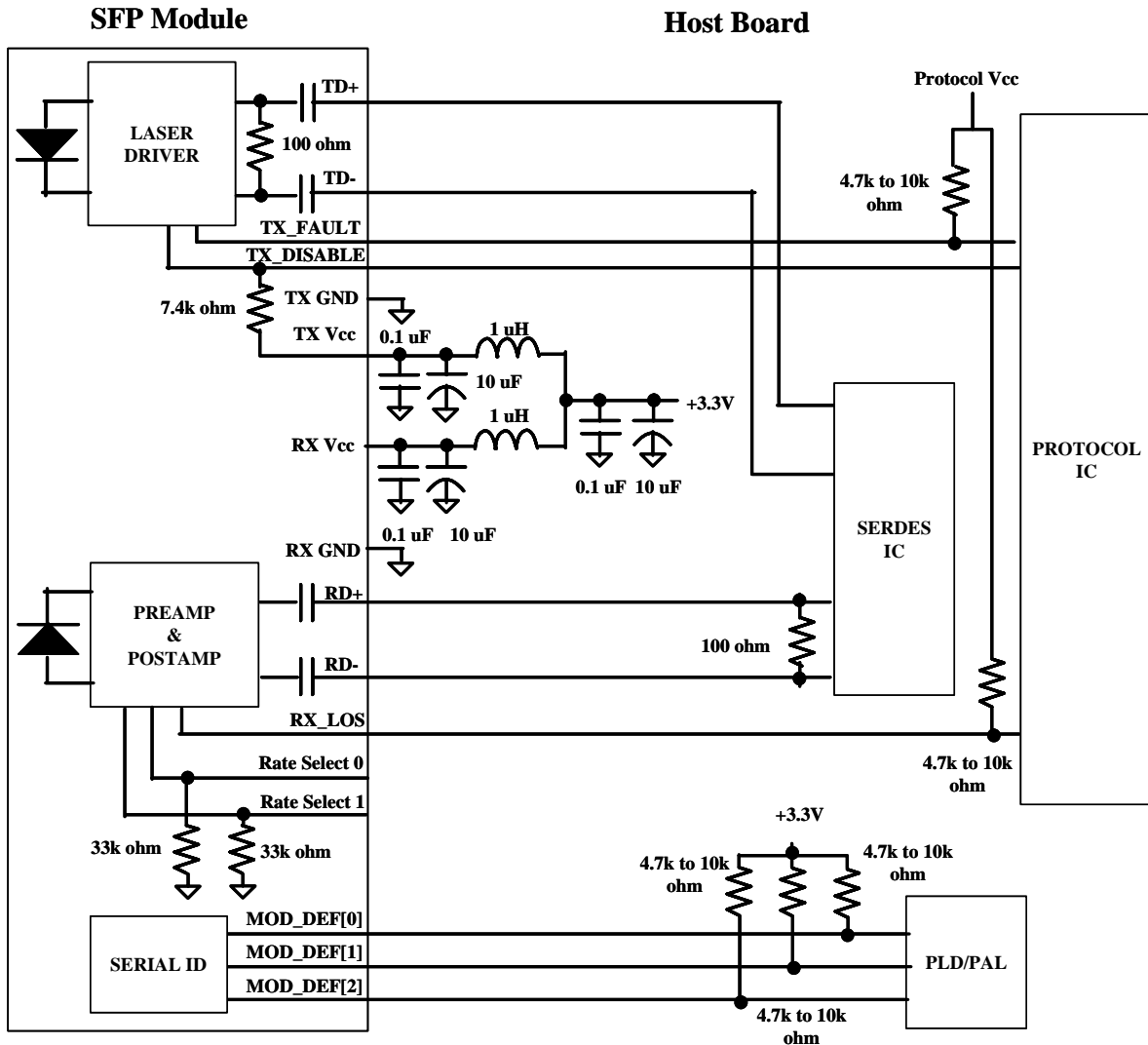

Figure 8
 Example of SFP Host Board Schematic



MITSUBISHI (OPTICAL DEVICES)
MF-27WXD Series
2.5Gbps SFP TRANSCEIVER MODULE

Figure 9 Serial ID Table

Data Address	Name of Field	Data [HEX]	ASCII	Data Address	Name of Field	Data [HEX]	ASCII
0	Identifier	03		64	Options	00	
1	Ext. Identifier	04		65	Options	1A	
2	Connector	07		66	BR, max	00	
3	Transceiver	00		67	BR, min	00	
4	Transceiver	0C		68	Vendor SN	note 4	*
5	Transceiver	00		69	Vendor SN	note 4	*
6	Transceiver	00		70	Vendor SN	note 4	*
7	Transceiver	00		71	Vendor SN	note 4	*
8	Transceiver	00		72	Vendor SN	note 4	*
9	Transceiver	00		73	Vendor SN	note 4	*
10	Transceiver	00		74	Vendor SN	note 4	*
11	Encoding	03		75	Vendor SN	note 4	*
12	BR, Nominal	19		76	Vendor SN	note 4	*
13	Reserved	00		77	Vendor SN	note 4	*
14	Length(9um)-km	50		78	Vendor SN	note 4	*
15	Length(9um)	FF		79	Vendor SN	note 4	*
16	Length(50um)	00		80	Vendor SN	note 4	*
17	Length(62.5um)	00		81	Vendor SN	note 4	*
18	Length(Copper)	00		82	Vendor SN	note 4	*
19	Reserved	00		83	Vendor SN	note 4	*
20	Vendor name	4D	M	84	Date code	note 5	*
21	Vendor name	49	I	85	Date code	note 5	*
22	Vendor name	54	T	86	Date code	note 5	*
23	Vendor name	53	S	87	Date code	note 5	*
24	Vendor name	55	U	88	Date code	note 5	*
25	Vendor name	42	B	89	Date code	note 5	*
26	Vendor name	49	I	90	Date code	note 5	*
27	Vendor name	53	S	91	Date code	note 5	*
28	Vendor name	48	H	92	Diagnostic Monitoring Type	58	
29	Vendor name	49	I	93	Enhanced Options	F0	
30	Vendor name	20	SPACE	94	SFF-8472 Compliance	01	
31	Vendor name	45	E	95	CC_EXT	note 3	
32	Vendor name	4C	L	96	Vendor Specific	note 6	
33	Vendor name	45	E	97	Vendor Specific	note 6	
34	Vendor name	43	C	98	Vendor Specific	note 6	
35	Vendor name	20	SPACE	99	Vendor Specific	note 6	
36	Reserved	00		100	Vendor Specific	note 6	
37	Vendor OUI	08		101	Vendor Specific	note 6	
38	Vendor OUI	00		102	Vendor Specific	note 6	
39	Vendor OUI	70		103	Vendor Specific	note 6	
40	Vendor PN	4D	M	104	Vendor Specific	note 6	
41	Vendor PN	46	F	105	Vendor Specific	note 6	
42	Vendor PN	2D	-	106	Vendor Specific	note 6	
43	Vendor PN	32	2	107	Vendor Specific	note 6	
44	Vendor PN	37	7	108	Vendor Specific	note 6	
45	Vendor PN	57	W	109	Vendor Specific	note 6	
46	Vendor PN	58	X	110	Vendor Specific	note 6	
47	Vendor PN	44	D	111	Vendor Specific	note 6	
48	Vendor PN	4D	M	112	Vendor Specific	note 6	
49	Vendor PN	34	4	113	Vendor Specific	note 6	
50	Vendor PN	31	1	114	Vendor Specific	note 6	
51	Vendor PN	5A	Z	115	Vendor Specific	note 6	
52	Vendor PN	41	A	116	Vendor Specific	note 6	
53	Vendor PN	43	C	117	Vendor Specific	note 6	
54	Vendor PN	note 1	*	118	Vendor Specific	note 6	
55	Vendor PN	note 1	*	119	Vendor Specific	note 6	
56	Vendor rev			120	Vendor Specific	note 6	
57	Vendor rev			121	Vendor Specific	note 6	
58	Vendor rev			122	Vendor Specific	note 6	
59	Vendor rev			123	Vendor Specific	note 6	
60	Wavelength (*)	note 2		124	Vendor Specific	note 6	
61	Wavelength (*)	note 2		125	Vendor Specific	note 6	
62	Reserved	00		126	Vendor Specific	note 6	
63	CC_BASE	note 3		127	Vendor Specific	note 6	

note 1 : These PN ASCII codes depend on wavelength..

Data Address(54/55): 1470nm;4/7, 1490nm;4/9, 1510nm;5/1, 1530nm;5/3,
1550nm;5/5, 1570nm;5/7, 1590nm;5/9, 1610nm;6/1

note 2 : These codes depend on wavelength.

Data Address(60/61): 1470nm;05/BE, 1490nm;05/D2, 1510nm;05/E6, 1530nm;05/FA,
1550nm; 06/OE, 1570nm;06/22, 1590nm;06/36, 1610nm;06/4A

note 3 : This code is check sum code.

note 4 : These address shows unique device serial number.

note 5 : These address shows date code.

note 6 : These address are vendor specific area. Read only.

11. Type Number

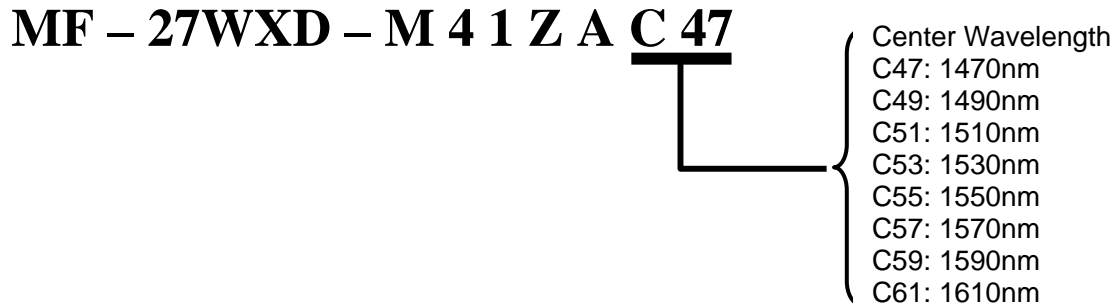

12. Implemented Digital Diagnostic Monitoring options

RATE SELECT (7 & 9 pin : refer to Section 8. Selective Bandwidth filtering function)
TX_DISABLE (3pin)
TX_FAULT (2pin)
Los Of Signal (8pin)
Alarm/warning flags
Soft TX_DISABLE control and monitoring
Soft TX_FAULT monitoring
Soft RX_LOS monitoring

13. Reliability reference

Telcordia GR-468-CORE
Radiated Emission:IEC61000-6-3
Immunity:IEC61000-4-2,IEC61000-4-3
Flammability:UL94V-0
ESD for PIN Interface: 500V by Human body model (with Rd=1500ohm and Cd=100pF)

14. Laser Safety Information

Class 1 Laser Product (IEC60825 and CDRH compliant)

15. Data sheet

Data sheet which is attached the SFP includes the below parameters.

Condition:

T-ambient 25deg.
Nominal Voltage
Data rate 2.48832Gbps
Data pattern PRBS2E23-1

Parameters:

- Optical Output Power
- Wavelength
- Spectral Width
- Supply Current
- Receiver Sensitivity
- Receiver Overload

16. General Outline Drawing

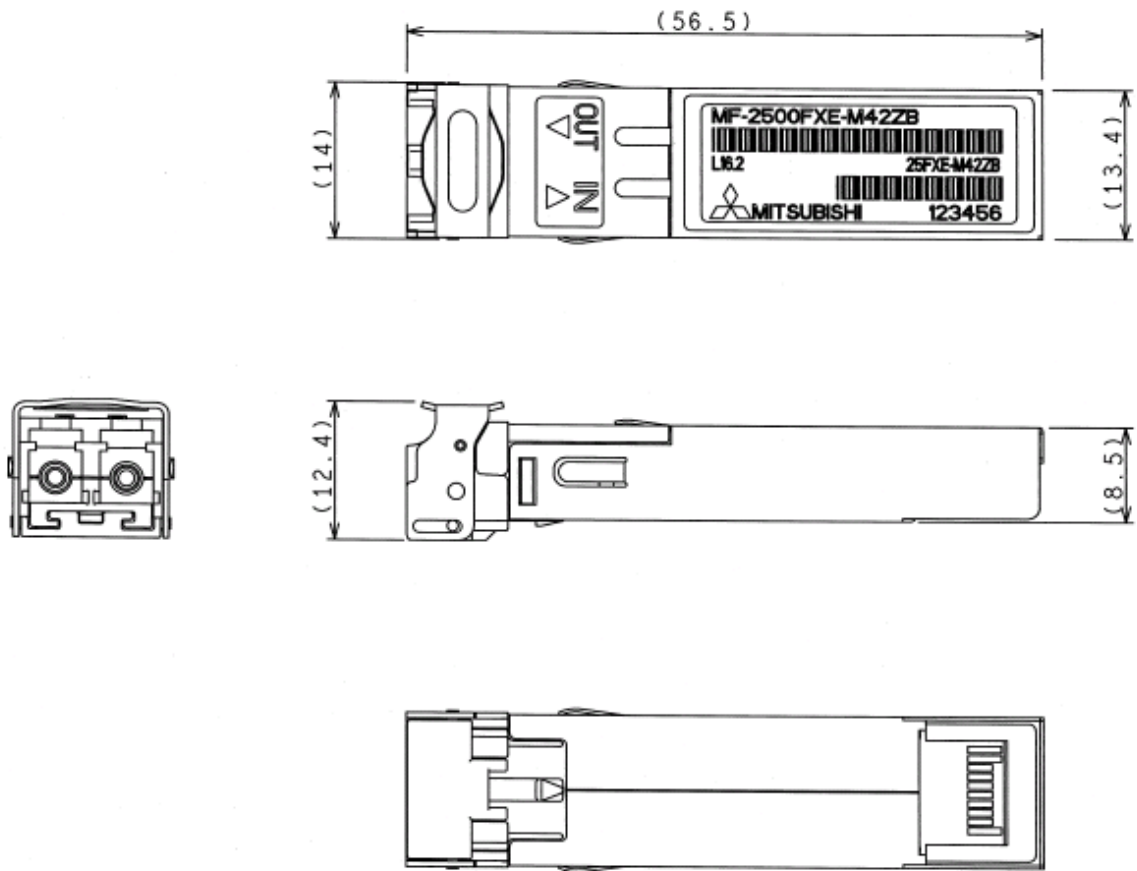

[unit: mm]

17. Packing

Ten SFPs are packed up in this packing box.

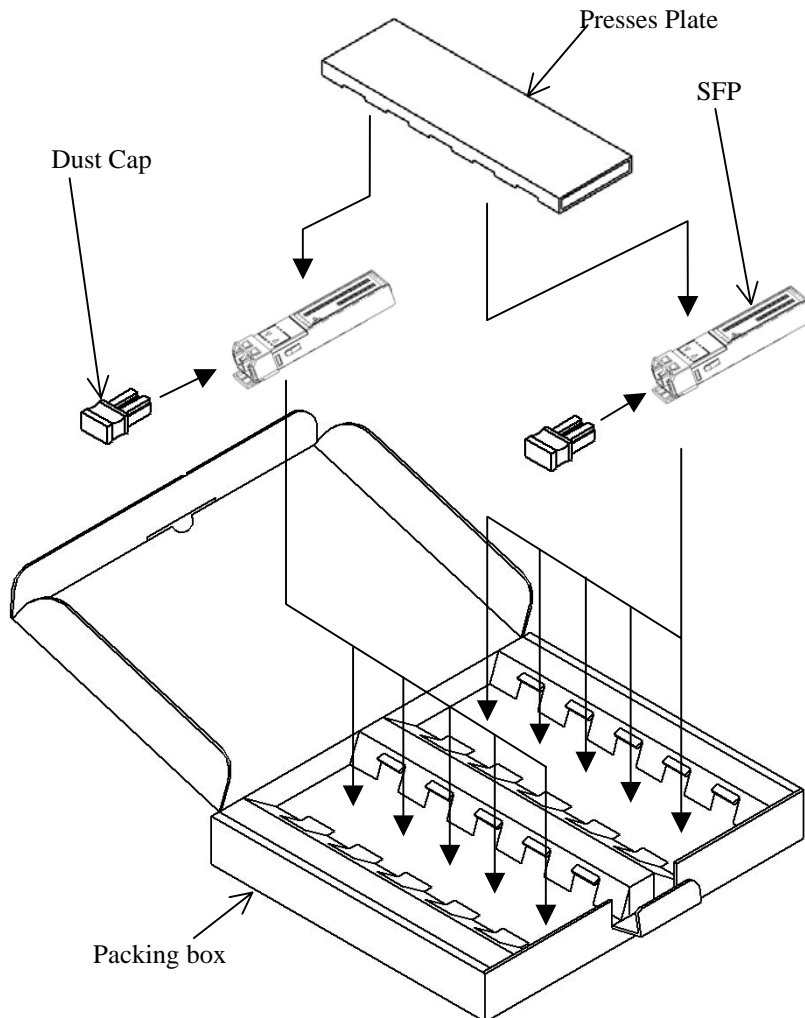

- Capacity: 10pcs. / box

- Packing box and Presses Plate material :
Cardboard with ESD protection coat.

This product is sensitive to electrostatic discharge. Take precautions to prevent ESD; use wrist straps, grounded work surfaces and recognized anti-static techniques when handling SFP module.

Mitsubishi reserves the right to change the circuitry and specifications without notice at any time.
No liability is assumed as a result of their use or application. No rights under any patent accompany
the sale of any such product(s) or information.

Safety Cautions for Use of Optoelectronic Devices

General:

Although the manufacturer is always striving to improve the reliability of its product, problems and errors may occur with semiconductor products. Therefore, the user's products are required to be designed with full safety regard to prevent any accidents that result in injury, death, fire or environmental damage even when semiconductor products happen to error. Especially it is recommended to take in consideration about redundancy, fire prevention, error prevention safeguards. And the following requirements must be strictly observed.

Warning!

- 1. Eye safety :** Semiconductor laser radiates laser light during operation. Laser light is very dangerous when shot directly into human eyes. Don't look at laser light directly, or through optics such as a lens. The laser light should be observed using the ITV camera, IR-viewer, or other appropriate instruments.
- 2. Product handling :** The product contains GaAs (gallium arsenide). It is safe for regular use, but harmful to the human body if made into powder or steam. Be sure to avoid dangerous process like smashing, burning, chemical etching. Never put this product in one's mouth or swallow it.
- 3. Product disposal :** This product must be disposed of as special industrial waste. It is necessary to separate it from general industrial waste and general garbage.

Handling Cautions for Optoelectronic Devices

1. General:

- (1) The products described in this specification are designed and manufactured for use in general communication systems or electronic devices, unless their applications or reliability are otherwise specified. Therefore, they are not designed or manufactured for installation in devices or systems that may affect human life or that are used in social infrastructure requiring high reliability.
- (2) When the customer is considering to use the products in special applications, such as transportation systems (automobiles, trains, vessels), medical equipments, aerospace, nuclear power control, and submarine repeaters or systems, please contact Mitsubishi Electric or an authorized distributor.

2. Shipping Conditions:

- (1) During shipment, place the packing boxes in the correct direction, and fix them firmly to keep them immovable. Placing the boxes upside down, tilting, or applying abnormal pressure onto them may cause deformation in the electrode terminals, breaking of optical fiber, or other problems.
- (2) Never throw or drop the packing boxes. Hard impact on the boxes may cause break of the devices.
- (3) Take strict precautions to keep the devices dry when shipping under rain or snow.

3. Storage Conditions:

When storing the products, it is recommended to store them following the conditions described below without opening the packing. Not taking enough care in storing may result in defects in electrical characteristics, soldering quality, visual appearance, and so on. The main points are described below (if special storage conditions are given to the product in the specification sheet, they have priority over the following general cautions):

- (1) Appropriate temperature and humidity conditions, i.e., temperature range between 5~30°C, and humidity between 40~60 percent RH, should be maintained in storage locations. Controlling the temperature and humidity within this range is particularly important in case of long-term storage for six months or more.
- (2) The atmosphere should be particularly free from toxic gases and dust.
- (3) Do not apply any load on the product.
- (4) Do not cut or bend the leads of the devices which are to be stored. This is to prevent corrosion in the cut or bent part of the lead causing soldering problems in the customer's assembling process.
- (5) Sudden change in temperature may cause condensation in the product or packing, therefore, such locations should be avoided for storing. Temperature in storage locations should be stable.
- (6) When storing ceramic package products for extended periods of time, the leads may turn reddish due to reaction with sulfur in the atmosphere.
- (7) Storage conditions for bare chip and unsealed products shall be stated separately because bare chip and unsealed products require stricter controls than package sealed products.

4. Design Conditions and Environment under Use:

- (1) Avoid use in locations where water or organic solvents adhere directly to the product, or where there is any possibility of the generation of corrosive gas, explosive gas, dust, salinity, or other troublesome conditions. Such environments will not only significantly lower the reliability, but also may lead to serious accidents.
- (2) Operation in excess of the absolute maximum ratings can cause permanent damage to the device. The customers are requested to design not to exceed those ratings even for a short time.

5. ESD Safety Cautions:

The optoelectronic devices are sensitive to static electricity (ESD, electro-static discharge). The product can be broken by ESD. When handling this product, please observe the following countermeasures:

<Countermeasures against Static Electricity and Surge>

To prevent break of devices by static electricity or surge, please adopt the following countermeasures in the assembly line:

- (1) Ground all equipments, machinery jigs, and tools in the process line with earth wires installed in them. Take particular care with hot plates, solder irons and other items for which the commercial power supplies are prone to leakage.
- (2) Workers should always use earth bands. Use of antistatic clothing, electric conductive shoes, and other safety equipment while at work is highly recommended.
- (3) Use conductive materials for this product's container, etc.
- (4) It is recommended that grounding mats be placed on the surfaces of assembly line workbench and the surrounding floor in work area, etc.
- (5) When mounting this product in parts or materials which can be electrically charged (printed wiring boards, plastic products, etc.), pay close attention to the static electricity in those parts. ESD may damage the product.
- (6) Humidity in working environment should be controlled to be 40 percent RH or higher. These countermeasures are most general, and there is a need to carefully confirm the line before starting mass production using this product (in the trial production, etc.). It is extremely important to prevent surge, eliminate it rapidly, and prevent it from spreading.

The end of document