



MG39133

*6 Taps, Linear LED driver
with sequential on/off control*

MG39133 Data Sheet

Version: V1.06

Contents

Features	3
1 Description	4
2 Order Information	4
3 Application Field	4
4 Pin Description	5
4.1 Pin Definition	5
4.2 Pin Configuration	5
5 Block Diagram	6
6 Application Circuit	6
7 Absolute Maximum Rating	7
8 Electrical Characteristics	7
9 Typical Performance Characteristic	8
10 Application information	9
11 Package Dimension	10
11.1 e-TSSOP16 Package Dimension	10
11.2 e-SOP16 Package Dimension	11
12 Revision History	11

Features

- I I_{LED} current is programmable with external resistor
- I Simple application, very few external components
- I No inductor, electrolytic capacitor
- I $PF > 0.9$
- I $THD_i < 25\%$
- I High LED utilization rate, 75%~90%
- I Over voltage protection
- I Temperature compensated
- I 16 Pin e-TSSOP, e-SOP Package

1 Description

The MG39133 is a high precision linear LED controller. It is designed to drive a 6-taps low power LED string directly from AC line input. Electrolytic capacitor is not required; so long operating life is possible. No EMI filter and PF correction circuits are needed.

The LED string is configured into 6 segments. With state-of-art control scheme, each segment is sequentially turned on and off by tracking the input sine wave voltage. Voltage applied on IC is minimized when conducting, providing high efficiency. The AC voltage and line -input current could be tuned in phase, so the high PF is possible. There is no PWM switching control in the chip, also the line-in current is tracking with the AC input with six step level, the THD; could be tuned very low. The I_{LED} current is also programmed by external resistor to fulfill various types of power requirement. The maximum supported wattage is 19.5W.

The MG39133 also builds in UVLO control, over temperature and over voltage protection circuit. The device is available in e-TSSOP16, e-SOP16 package or dice form.

2 Order Information

Current	120mA (Max)
Package Type	
Dice	MG39133AH
e-TSSOP16	MG39133AT
e-SOP16	MG39133AS

3 Application Field

Incandescent and Fluorescent lamp/tube replacement

4 Pin Description

4.1 Pin Definition

Pin No.	Pin Name	I/O	Description
1	VTH1	I	LED power down control pin; $V_{TH1} < 1.2V$ ⇒ Power down
2	GND	G	Ground pin
3	SET1	IO	Current control input for TAP1
4	SET2	IO	Current control input for TAP2
5	SET3	IO	Current control input for TAP3
6	SET4	IO	Current control input for TAP4
7	SET5	IO	Current control input for TAP5
8	SET6	IO	Current control input for TAP6
9	TAP6	O	Current regulator 6 output, connect it to tap of LED string
10	TAP5	O	Current regulator 5 output, connect it to tap of LED string
11	TAP4	O	Current regulator 4 output, connect it to tap of LED string
12	TAP3	O	Current regulator 3 output, connect it to tap of LED string
13	TAP2	O	Current regulator 2 output, connect it to tap of LED string
14	TAP1	O	Current regulator 1 output, connect it to tap of LED string
15	VIN	I	High voltage input pin, connect to rectified AC
16	VTH2	I	LED power down control pin; $V_{TH2} > 1.2V$ ⇒ Power down

4.2 Pin Configuration

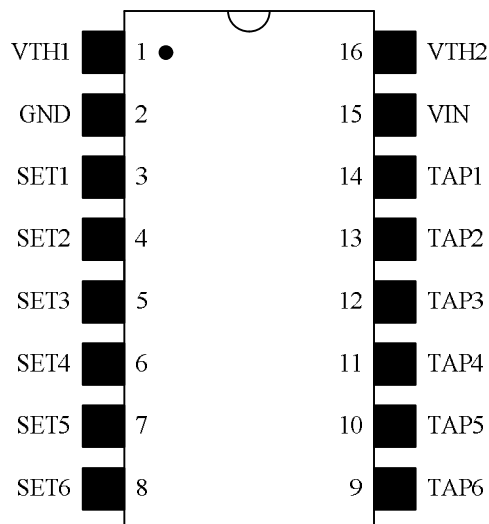

5 Block Diagram

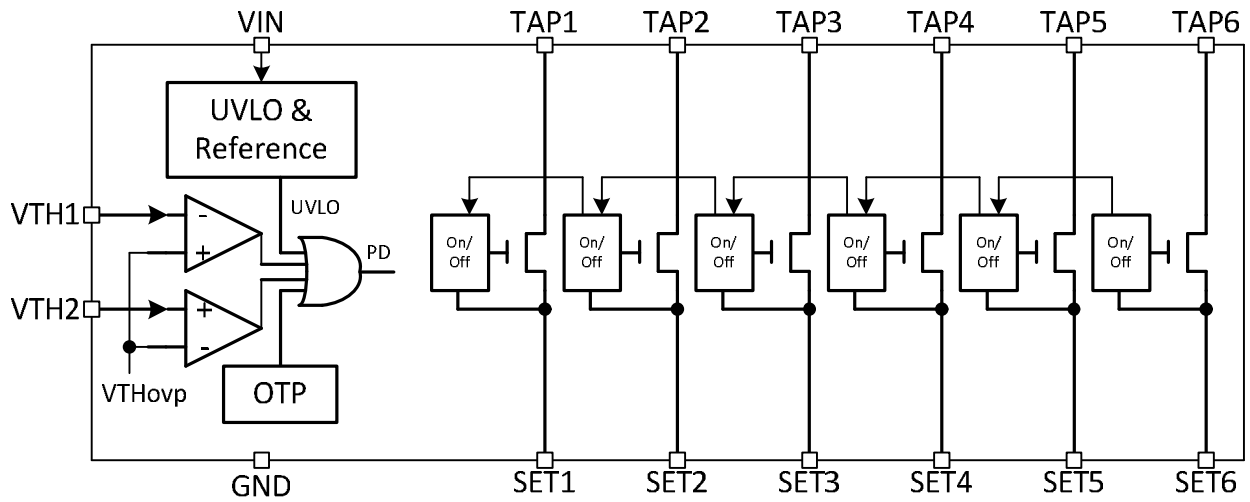

6 Application Circuit

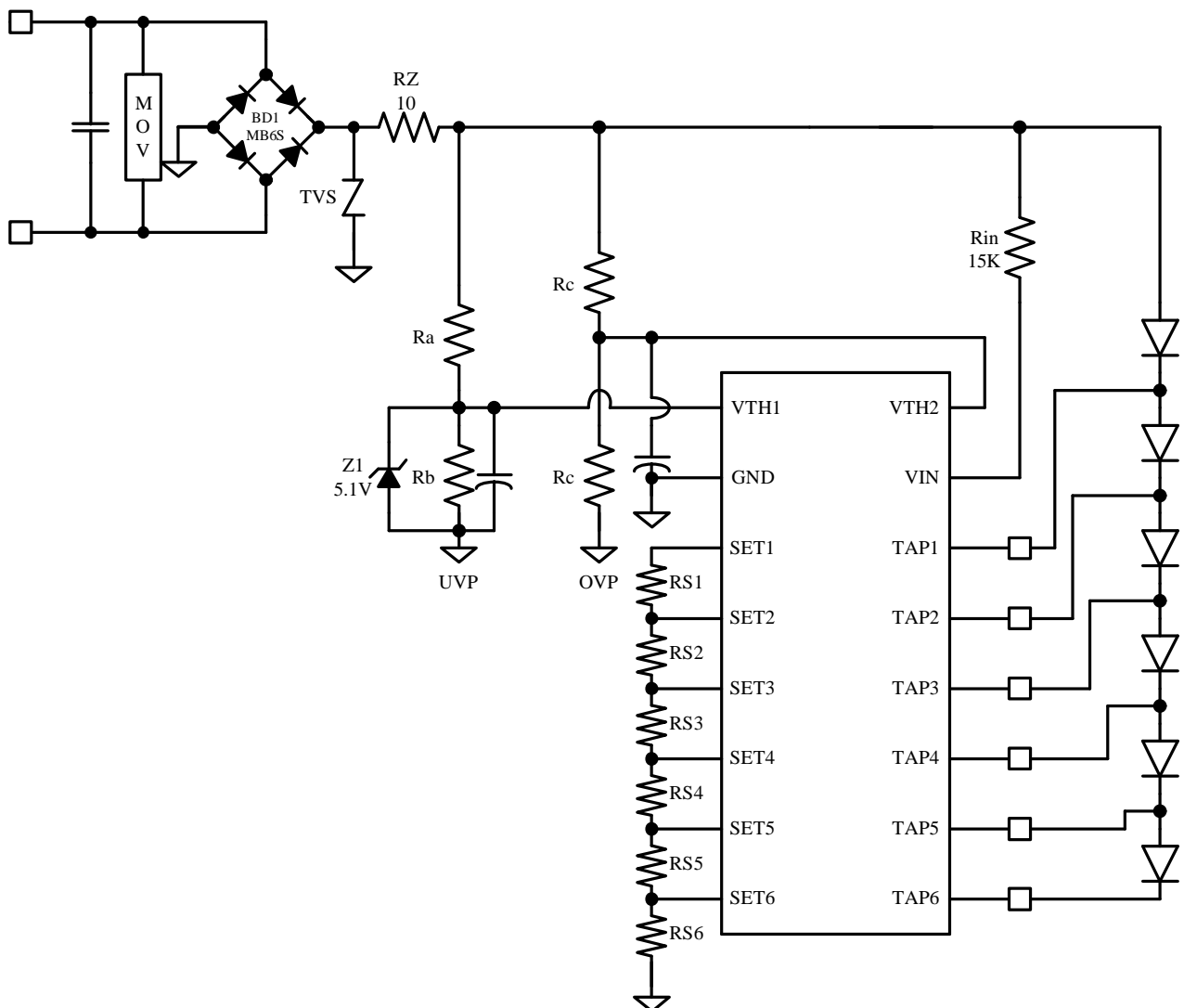

7 Absolute Maximum Rating

Parameter	Rating	Unit
V _{IN} Supply Voltage	-0.5 to +530	V
Operating temperature	-40 to +125	°C
Storage temperature	-55 to +155	°C

Note: Operating temperature is strongly related to the power consumption of IC.

8 Electrical Characteristics

Parameter	Symbol	Conditions	Min.	Typ.	Max.	Unit
Input Voltage	V _{IN}	V _{VIN} - V _{GND}	7.5	-	500	V
V _{IN} Start-up Voltage	V _{START}	V _{VIN} - V _{GND}	-	6.5	-	V
V _{IN} UVLO Voltage	V _{UVLO}	V _{VIN} - V _{GND}	-	5.5	-	V
Input Current	I _{IN}	All input range	-	400	-	uA
Input Current at UVLO	I _{UVLO}	All input range	-	100	-	uA
SET1~4 Compare Level	V _{SETa}	All input range	-	1.1	-	V
SET5~6 Compare Level	V _{SETb}	All input range	-	1.2	-	V
SET1 ~ SET6 Compare Level Temperature Coefficient	$\Delta V_{SET}/\Delta T$	Junction Temperature (T _J): -40°C ~ +125°C	-	-0.03	-	%/°C
OVP/UVLP Compare Level	V _{TH1,2}	All input range	-	1.2	-	V
TAPx Current	I _{TAP1-2}	V _{TAP} = 10V, T _J = 125 °C	-	-	50	mA
	I _{TAP3-6}	V _{TAP} = 10V, T _J = 125 °C	-	-	120	mA
Applied Voltage on TAP	V _{TAPa}	TAP1, Non-conducting ^{*1}	-	-	500	V
	V _{TAPb}	TAP2 ~6, Non-conducting ^{*1}	-	-	250	V
OTP Protection Temperature	T _{JOTP}	Junction Temperature	-	160	-	°C
OTP Hysteresis Window	T _{JOTPHW}		-	50	-	°C

Note: *1, Applied voltage is determined by power dissipation.

9 Typical Performance Characteristic

$I_{TAP1&2}$ Current vs. V_{in} Voltage / Temperature

Current set to around 45mA

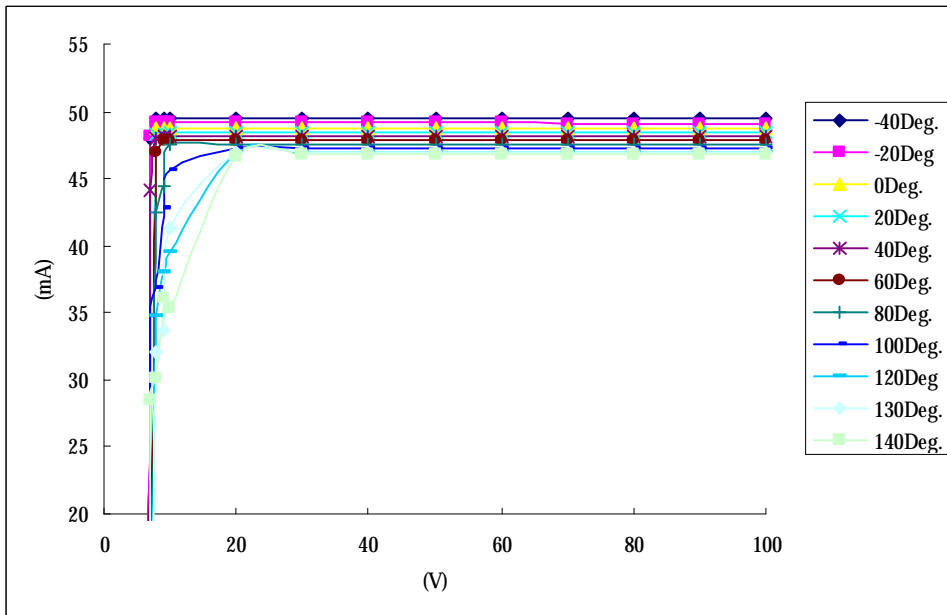

$I_{TAPS3-6}$ Current vs. V_{IN} voltage / Temperature

Current set to around 95mA

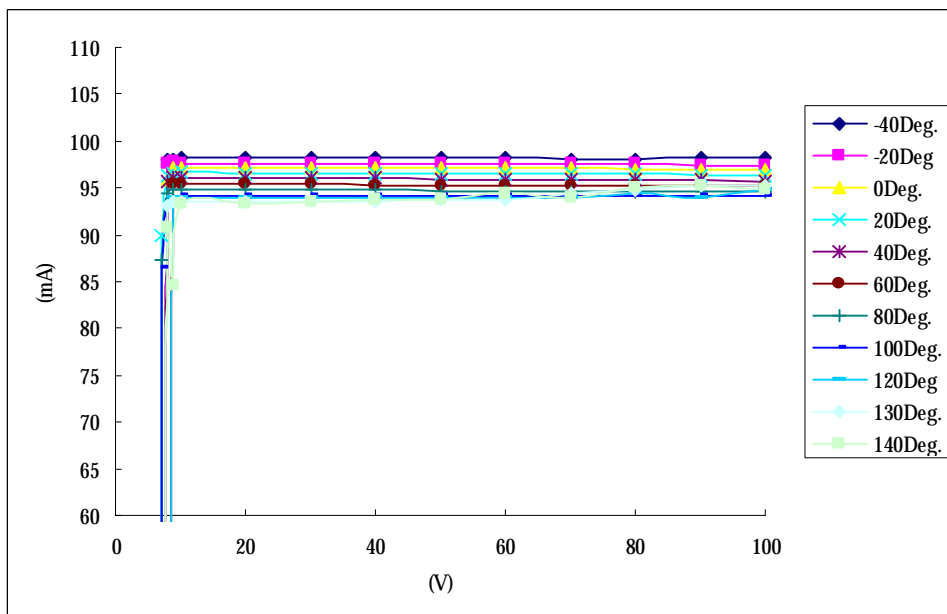

10 Application information

Current Setting

If the application circuit is same as below

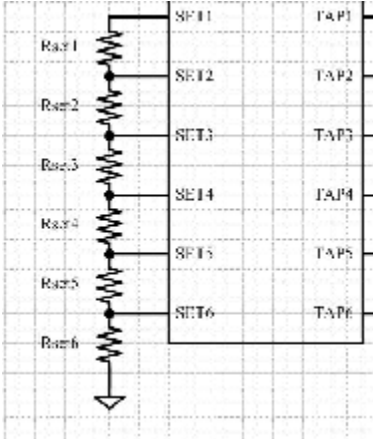

The current setting will be

$$I_{TAP6} = (1.2V \div (R_{SET6}))$$

$$I_{TAP5} = (1.1V \div (R_{SET6} + R_{SET5}))$$

$$I_{TAP4} = (1.1V \div (R_{SET6} + R_{SET5} + R_{SET4}))$$

$$I_{TAP3} = (1.1V \div (R_{SET6} + R_{SET5} + R_{SET4} + R_{SET3}))$$

$$I_{TAP2} = (1.1V \div (R_{SET6} + R_{SET5} + R_{SET4} + R_{SET3} + R_{SET2}))$$

$$I_{TAP1} = (1.1V \div (R_{SET6} + R_{SET5} + R_{SET4} + R_{SET3} + R_{SET2} + R_{SET1}))$$

$$R_{SET6} = (1.2V \div I_{TAP6})$$

$$R_{SET5} = (1.1V \div I_{TAP5}) - R_{SET6}$$

$$R_{SET4} = (1.1V \div I_{TAP4}) - R_{SET6} - R_{SET5}$$

$$R_{SET3} = (1.1V \div I_{TAP3}) - R_{SET6} - R_{SET5} - R_{SET4}$$

$$R_{SET2} = (1.1V \div I_{TAP2}) - R_{SET6} - R_{SET5} - R_{SET4} - R_{SET3}$$

$$R_{SET1} = (1.1V \div I_{TAP1}) - R_{SET6} - R_{SET5} - R_{SET4} - R_{SET3} - R_{SET2}$$

The MG39133 can sustain an input voltage level as high as 500V. But users should care the heat dissipation issue for their applications. For large wattage application, the 131 will consumes 2W~3W power. The IC's heat-sink should be firmly attached to the substrate. Aluminum or Ceramic PCB is recommended.

Package Thermal Resistance

The thermal resistance is around 66°C /W, junction to ambient (no air flow)

Note: Rule of thumb, it is suggested that the IC surface temperature is maintained below 90 (Celsius degree). For ETSSOP16 package, maintain the power dissipation below 1.5W.

11 Package Dimension

11.1 e-TSSOP16 Package Dimension

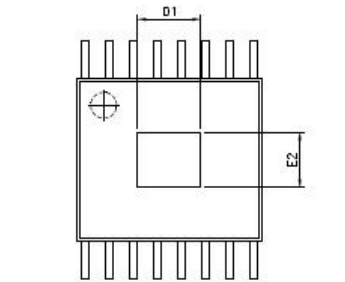
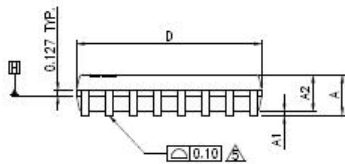
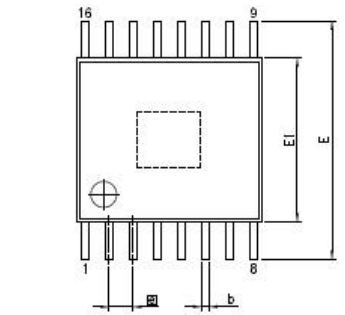

THERMALLY ENHANCED VARIATIONS ONLY

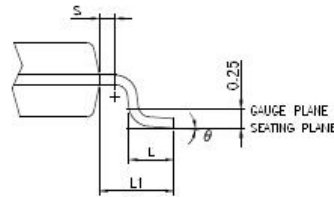

VARIATIONS (ALL DIMENSIONS SHOWN IN MM)

SYMBOLS	MIN.	NOM.	MAX.
A	—	—	1.20
A1	0.00	—	0.15
A2	0.80	1.00	1.05
b	0.19	—	0.30
D	4.90	5.00	5.10
E1	4.30	4.40	4.50
E	6.40 BSC		
E	0.65 BSC		
LI	1.00 REF		
L	0.45	0.60	0.75
S	0.20	—	—
θ	0°	—	8°

THERMALLY ENHANCED DIMENSIONS/SHOWN IN MM)

PAD SIZE	E2		D1	
	MIN.	MAX.	MIN.	MAX.
118X11E	2.40	3.00	2.40	3.00

NOTES:

1. JEDEC OUTLINE :
STANDARD : MO-153 AB REV.F
THERMALLY ENHANCED : MO-153 ABT REV.F
2. DIMENSION 'D' DOES NOT INCLUDE MOLD FLASH, PROTRUSIONS OR GATE BURRS. MOLD FLASH, PROTRUSIONS OR GATE BURRS SHALL NOT EXCEED 0.15 PER SIDE.
3. DIMENSION 'E1' DOES NOT INCLUDE INTERLEAD FLASH OR PROTRUSION. INTERLEAD FLASH OR PROTRUSION SHALL NOT EXCEED 0.25 PER SIDE.
4. DIMENSION 'b' DOES NOT INCLUDE DAMBAR PROTRUSION. ALLOWABLE DAMBAR PROTRUSION SHALL BE 0.05 MM TOTAL IN EXCESS OF THE 'b' DIMENSION AT MAXIMUM MATERIAL CONDITION. DAMBAR CANNOT BE LOCATED ON THE LOWER FACIUS OF THE FOOT. MINIMUM SPACE BETWEEN PROTRUSION AND ADJACENT LEAD IS 0.07 MM.
5. DIMENSIONS 'D' AND 'E1' TO BE DETERMINED AT DATUM PLANE **B**.

11.2 e-SOP16 Package Dimension

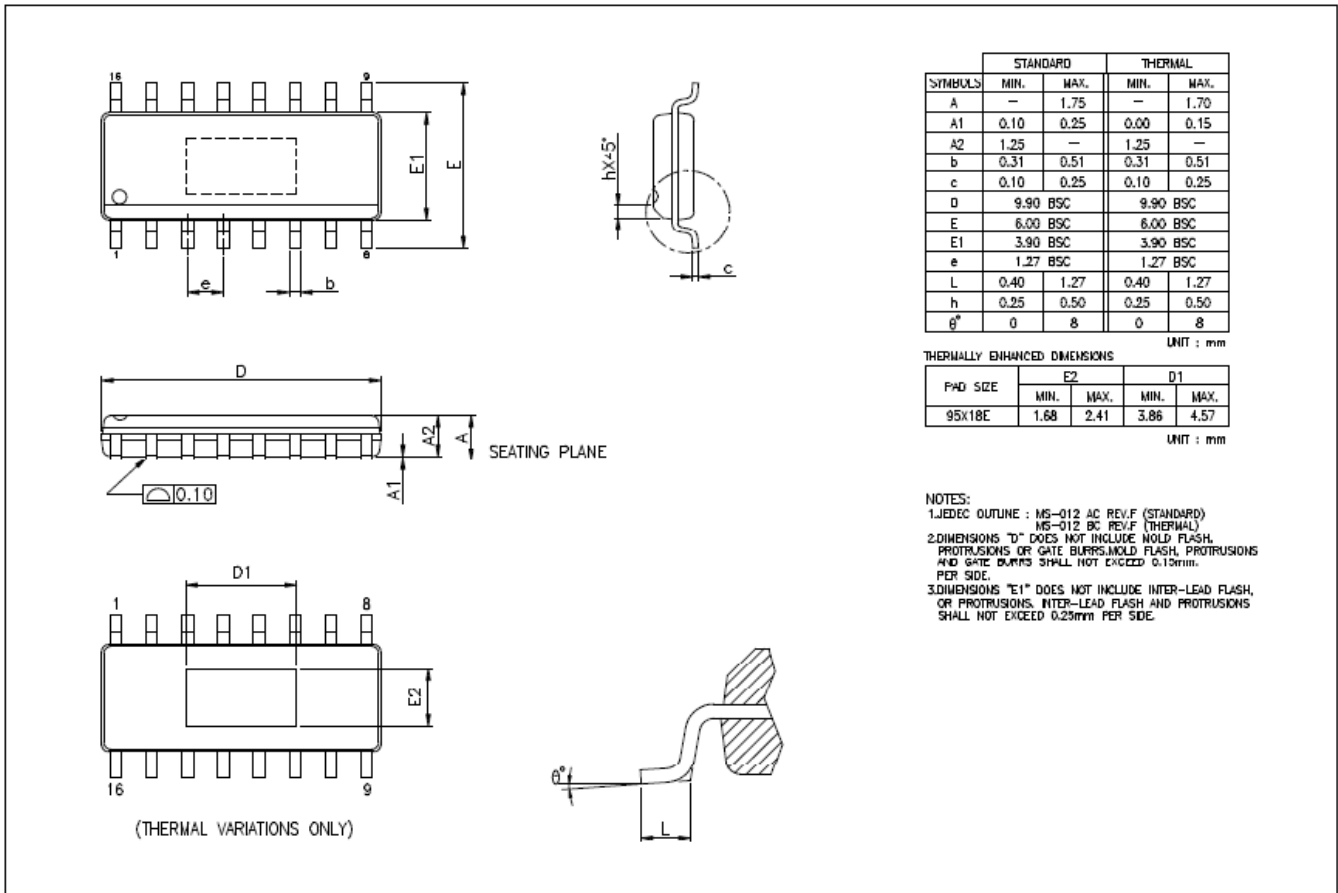

12 Revision History

Rev	Descriptions	Date
V1.01	Initial release.	2013/01/29
V1.02	Modify the package	2013/05/20
V1.03	Modify the TAP current	2013/08/06
V1.04	Rename Model name	2014/02/07
V1.05	Modify VTH1 polarity	2014/05/26
V1.06	Add test data and revise application diagram	2014/07/24