

MG86FE/L104

Data Sheet

Version: A1.5

Features

- 1-T 80C51 Central Processing Unit
- **MG86FE/L104** with 4K Bytes flash ROM
 - ISP memory zone could be optioned as 0.5KB/1KB/1.5KB.....3.5KB
 - Flexible IAP size.
 - Code protection for flash memory access
 - Flash write/erase cycle
 - ◆ For 0.5K IAP, the MTP of IAP write cycle is 2,000 times.
 - ◆ For 1.0K IAP, the MTP of IAP write cycle is 1,000 times
 - Flash data retention: 100 years at 25°C
 - **MG86FE/L104 Flash space mapping (Default)**
 - ◆ **AP Flash (0000h~07FFh)**
 - ◆ **IAP Flash (0800h~0BFFh)**
 - ◆ **ISP Flash (0C00h~0FFFh) (ISP Boot code)**
- On-chip 256 bytes scratch-pad RAM
- Interrupt controller
 - 6 sources, four-level-priority interrupt capability
 - Two external interrupt inputs, nINT0 and nINT1.
 - All external interrupts support High/Low level or Rising/Falling edge trigger.
- Two 16-bit timer/counters, Timer 0 and Timer 1.
 - T0CKO on P34 and T1CKO on P35.
 - X12 mode enabled for T0/T1.
- Enhanced UART (S0)
 - Framing Error Detection
 - Automatic Address Recognition
 - a speed improvement mechanism (X2/X4 mode)
 - 4 channel UART repeater mechanism
- Keypad Interrupt on all GPIO.
- Programmable Watchdog Timer
 - One time enabled by CPU or power-on
 - Sourced from on-chip low frequency oscillator (ILRCO)
 - Interrupt CPU or Reset CPU on WDT overflow
 - Support WDT function in power down mode
- Maximum 18 GPIOs in 20-pin package.
 - P3 can be configured to quasi-bidirectional, push-pull output, open-drain output and input only.
 - P1, P4.0 and P4.1 can be configured to push-pull output or open-drain output.
 - P4.0, P4.1 and P3.6 are shared with XTAL2, XTAL1 and RST.
 - All GPIOs have wakeup capability.
- Multiple power control modes: idle mode, power-down mode, slow mode, sub-clock mode, watch mode and monitor mode.
 - All interrupts can wake up IDLE mode
 - 6 sources to wake up Power-Down mode
 - Slow mode and sub-clock mode support low speed MCU operation
 - Watch mode supports WDT to resume CPU in power down
 - Monitor mode supports BOD0 to resume CPU in power down (L-series only)
- Brown-Out Detector: VDD 4.2V for E-series and VDD 2.4V for L-series
 - Interrupt CPU or reset CPU
 - Wake up CPU in Power-Down mode (L-series only)

- Operating voltage:
 - MG86FE104: 4.2V~5.5V, minimum 4.5V requirement in flash write operation (ISP/IAP/ICP)
 - MG86FL104: 2.4V~3.6V, minimum 2.7V requirement in flash write operation (ISP/IAP/ICP)
- Operating frequency range: 25MHz(max)
 - MG86FE104: 0 – 12MHz @ 4.2V – 5.5V and 0 – 25MHz @ 4.5V – 5.5V
 - MG86FL104: 0 – 12MHz @ 2.4V – 3.6V and 0 – 25MHz @ 2.7V – 3.6V
- Clock Source:
 - Internal 24MHz/22.118MHz oscillator (IHRCO): factory calibrated to $\pm 1\%$, typical
 - External crystal mode
 - Internal Low frequency RC Oscillator (ILRCO) support (about 64KHz)
 - External clock input (ECKI) on XTAL2/P4.0
 - Internal Oscillator output on XTAL2/P4.0
- Operating Temperature:
 - Industrial (-40°C to +85°C)*
- Package Types:
 - SOP20: MG86FE/L104AS20
 - SOP16: MG86FE/L104AS16
 - SOP8: MG86FE/L104AS8

*: Tested by sampling.

Content

Features	3
Content	5
1. General Description	9
2. Block Diagram	10
3. Special Function Register	11
3.1. SFR Map	11
3.2. SFR Bit Assignment.....	12
3.3. Auxiliary SFR Map (Page P)	13
3.4. Auxiliary SFR Bit Assignment (Page P)	14
4. Pin Configurations.....	15
4.1. Package Instruction	15
4.2. Pin Description	16
5. 8051 CPU Function Description	17
5.1. CPU Register.....	17
5.2. CPU Timing	19
5.3. CPU Addressing Mode	19
6. Memory Organization.....	20
6.1. On-Chip Program Flash.....	20
6.2. On-Chip Data RAM.....	21
6.3. Declaration Identifiers in a C51-Compiler.....	23
7. Data Pointer Register (DPTR).....	24
8. System Clock.....	25
8.1. Clock Structure	25
8.2. Clock Register	26
8.3. Clock Sample Code	28
9. Watch Dog Timer (WDT)	31
9.1. WDT Structure.....	31
9.2. WDT During Idle and Power Down	31
9.3. WDT Register	32
9.4. WDT Hardware Option.....	33
9.5. WDT Sample Code.....	34
10. System Reset	36
10.1. Reset Source.....	36
10.2. Power-On Reset	36
10.3. External Reset	37
10.4. Software Reset	37
10.5. Illegal Address Reset.....	37
10.6. Brown-Out Reset	38
10.7. WDT Reset.....	38
10.8. Reset Sample Code.....	39
11. Power Management.....	40
11.1. Brown-Out Detector	40
11.2. Power Saving Mode.....	40
11.2.1. Slow Mode	40
11.2.2. Sub-Clock Mode	40
11.2.3. Watch Mode	41
11.2.4. Monitor Mode (L-Series Only)	41
11.2.5. Idle Mode.....	41

11.2.6. Power-Down Mode	41
11.2.7. Interrupt Recovery from Power-down.....	42
11.2.8. Reset Recovery from Power-down.....	42
11.2.9. KBI Recovery from Power-down	43
11.3. Power Control Register.....	44
11.4. Power Control Sample Code	46
12. Configurable I/O Ports	51
12.1. IO Structure	51
12.1.1. Port 3 Quasi-Bidirectional IO Structure	51
12.1.2. Port 3 Push-Pull Output Structure	52
12.1.3. Port 3 Input-Only (High Impedance Input) Structure.....	52
12.1.4. Port 3 Open-Drain Output Structure.....	53
12.1.5. General Open-Drain Output Structure.....	53
12.1.6. General Push-Pull Output Structure.....	53
12.1.7. General Port Input Configured	54
12.2. I/O Port Register.....	55
12.2.1. Port 1 Register.....	55
12.2.2. Port 3 Register.....	55
12.2.3. Port 4 Register.....	56
12.2.4. Pull-Up Control Register	56
12.3. GPIO Sample Code	58
13. Interrupt	59
13.1. Interrupt Structure.....	59
13.2. Interrupt Source.....	60
13.3. Interrupt Enable	61
13.4. Interrupt Priority	61
13.5. Interrupt Process	62
13.6. Special Interrupt Vector for TI	62
13.7. Interrupt Register.....	63
13.8. Interrupt Sample Code.....	66
14. Timers/Counters	67
14.1. Timer0 and Timer1	67
14.1.1. Mode 0 Structure	67
14.1.2. Mode 1 Structure	68
14.1.3. Mode 2 Structure	68
14.1.4. Mode 3 Structure	69
14.1.5. Timer 0/1 Programmable Clock-Out.....	69
14.1.6. Timer0/1 Register	71
14.1.7. Timer0/1 Sample Code	73
15. Serial Port (UART)	76
15.1. Serial Port Mode 0.....	77
15.2. Serial Port Mode 1	79
15.3. Serial Port Mode 2 and Mode 3	80
15.4. Frame Error Detection	80
15.5. Multiprocessor Communications.....	81
15.6. Automatic Address Recognition.....	81
15.7. Baud Rate Setting.....	83
15.7.1. Baud Rate in Mode 0	83
15.7.2. Baud Rate in Mode 2	83
15.7.3. Baud Rate in Mode 1 & 3.....	83
15.8. Serial Port Repeater Mode	87
15.9. Serial Port Register.....	88
15.10. Serial Port Sample Code	92
16. Keypad Interrupt (KBI)	93
16.1. Keypad Interrupt Structure.....	93

16.2.	Keypad Interrupt Register	93
16.3.	Keypad Interrupt Sample Code.....	95
17.	ISP and IAP	96
17.1.	Flash Memory Configuration.....	96
17.2.	In-System-Programming (ISP).....	97
17.2.1.	ISP/IAP Register.....	97
17.2.2.	Description for ISP Operation	99
17.2.3.	Sample Code for ISP	100
17.3.	In-Application-Programming (IAP)	101
17.3.1.	IAP-memory Boundary/Range	101
17.3.2.	Update data in IAP-memory.....	101
17.4.	ISP/IAP Sample Code	102
18.	Page P SFR Access	107
18.1.	Page-P Sample Code	110
19.	Auxiliary SFRs	112
20.	Hardware Option.....	114
21.	Application Notes.....	116
21.1.	Power Supply Circuit	116
21.2.	Reset Circuit.....	116
21.3.	XTAL Oscillating Circuit	117
21.4.	ICP Interface Circuit.....	118
22.	Electrical Characteristics.....	119
22.1.	Absolute Maximum Rating	119
22.2.	DC Characteristics.....	120
22.3.	External Clock Characteristics	124
22.4.	IHRCO Characteristics.....	125
22.5.	ILRCO Characteristics	125
22.6.	Flash Characteristics	126
22.7.	Serial Port Timing Characteristics.....	126
23.	Instruction Set.....	127
24.	Package Dimension	130
24.1.	SOP-20.....	130
24.2.	SOP-16.....	131
24.3.	SOP-8.....	132
25.	Revision History.....	133

1. General Description

The **MG86FE/L104** is a single-chip microcontroller based on a high performance 1-T architecture 80C51 CPU that executes instructions in 1~6 clock cycles (about 6~7 times the rate of a standard 8051 device), and has an 8051 compatible instruction set. Therefore at the same performance as the standard 8051, the **MG86FE/L104** can operate at a much lower speed and thereby greatly reduce the power consumption.

The **MG86FE/L104** has 4K bytes of embedded Flash memory for code and data. The Flash memory can be programmed either in serial writer mode (via ICP, In-Circuit-Programming) or in ISP (In-System Programming) mode. And, it also provides the In-Application Programming (IAP) capability. ICP and ISP allow the user to download new code without removing the microcontroller from the actual end product; IAP means that the device can write non-volatile data in the Flash memory while the application program is running. There needs no external high voltage for programming due to its built-in charge-pumping circuitry.

The **MG86FE/L104** retains all features of the standard 80C52 with 256 bytes of scratch-pad RAM, two 8bit I/O ports, two external interrupts with High/Low trigger option, a multi-source 4-level interrupt controller and two 16-bits timer/counters. In addition, the **MG86FE/L104** has two extra I/O pins (P4.0 and P4.1), keypad interrupt, an one-time enabled Watchdog Timer, a Brown-out Detector, an on-chip crystal oscillator (shared with P4.0 and P4.1), a high precision internal oscillator (IHRCO), an internal low speed RC oscillator (ILRCO) and a more versatile serial channel that facilitates multiprocessor communication (EUART) and a speed improvement mechanism (X2/X4 mode).

The **MG86FE/L104** has multiple operating modes to reduce the power consumption: idle mode, power down mode, slow mode, sub-clock mode, watch mode and monitor mode. In the Idle mode the CPU is frozen while the peripherals and the interrupt system are still operating. In the Power-Down mode the RAM and SFRs' value are saved and all other functions are inoperative; most importantly, in the Power-down mode the device can be waked up by many interrupt or reset sources. In slow mode, the user can further reduce the power consumption by using the 8-bit system clock pre-scaler to slow down the operating speed. Or select sub-clock mode which clock source is derived from internal low speed oscillator (ILRCO) for CPU to perform an ultra low speed operation. In watch mode, it keeps WDT running in power-down or idle mode and resumes CPU when WDT overflows. Monitor mode provides the Brown-Out detection in power down mode and resumes CPU when chip VDD reaches the specific detection level.

2. Block Diagram

Figure 2-1. Block Diagram

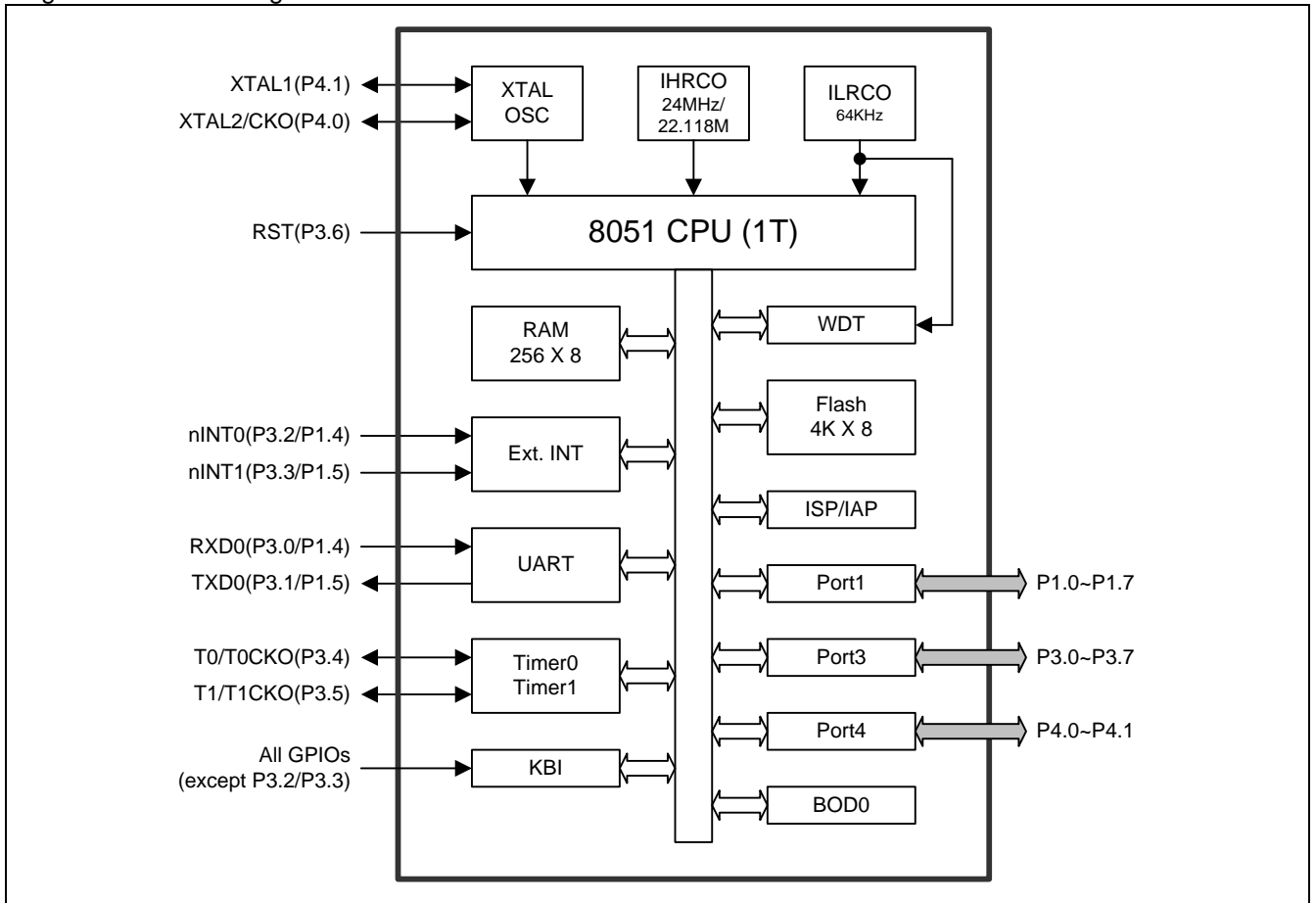

3. Special Function Register

3.1. SFR Map

Table 3-1. SFR Map

	0/8	1/9	2/A	3/B	4/C	5/D	6/E	7/F
F8	--	--	--	--	--	--	--	--
F0	B	--	--	--	--	--	--	--
E8	P4	--	--	--	--	--	--	--
E0	ACC	WDTCR	IFD	IFADRH	IFADRL	IFMT	SCMD	ISPCR
D8	--	--	--	--	--	--	--	--
D0	PSW	--	--	--	--	--	P3KBIE	P1KBIE
C8	--	--	--	--	--	--	--	--
C0	--	--	--	--	--	--	--	CKCON0
B8	IP0L	SADEN	--	--	--	--	--	--
B0	P3	P3M0	P3M1	P4M0	PUCON0			IP0H
A8	IE	SADDR	--	--		EIE1	EIP1L	EIP1H
A0	--	AUXR0	AUXR1	AUXR2	--	--	--	--
98	SCON	SBUF	--	--	--	--		
90	P1	P1M0	--	--	--	--	--	PCON1
88	TCON	TMOD	TL0	TL1	TH0	TH1	SFIE	--
80	--	SP	DPL	DPH	--	--	--	PCON0
	0/8	1/9	2/A	3/B	4/C	5/D	6/E	7/F

3.2. SFR Bit Assignment

Table 3–2. SFR Bit Assignment

SYMBOL	DESCRIPTION	ADDR	BIT ADDRESS AND SYMBOL								RESET VALUE
			Bit-7	Bit-6	Bit-5	Bit-4	Bit-3	Bit-2	Bit-1	Bit-0	
SP	Stack Pointer	81H									00000111B
DPL	Data Pointer Low	82H									00000000B
DPH	Data Pointer High	83H									00000000B
PCON0	Power Control 0	87H	SMOD1	SMOD0	GF	POF	GF1	GF0	PD	IDL	00010000B
<i>TCON</i>	<i>Timer Control</i>	<i>88H</i>	<i>TF1</i>	<i>TR1</i>	<i>TF0</i>	<i>TR0</i>	<i>IE1</i>	<i>IT1</i>	<i>IE0</i>	<i>IT0</i>	<i>00000000B</i>
TMOD	Timer Mode	89H	GATE	C/T	M1	M0	GATE	C/T	M1	M0	00000000B
TL0	Timer Low 0	8AH									00000000B
TL1	Timer Low 1	8BH									00000000B
TH0	Timer High 0	8CH									00000000B
TH1	Timer High 1	8DH									00000000B
SFIE	System Flag INT En.	8EH	UTIE	--	--	--	KBIFIE	--	BOF0IE	WDTFIE	0xxx0xxxB
<i>P1</i>	<i>Port 1</i>	<i>90H</i>	<i>P1.7</i>	<i>P1.6</i>	<i>P1.5</i>	<i>P1.4</i>	<i>P1.3</i>	<i>P1.2</i>	<i>P1.1</i>	<i>P1.0</i>	<i>11111111B</i>
P1M0	P1 Mode Register 0	91H	P1M0.7	P1M0.6	P1M0.5	P1M0.4	P1M0.3	P1M0.2	P1M0.1	P1M0.0	00000000B
PCON1	Power Control 1	97H	SWRF	EXRF	--	--	KBIF	--	BOF0	WDTF	00100x00B
<i>SCON</i>	<i>Serial Control</i>	<i>98H</i>	<i>SM0/FE</i>	<i>SM1</i>	<i>SM2</i>	<i>REN</i>	<i>TB8</i>	<i>RB8</i>	<i>Ti</i>	<i>RI</i>	<i>00000000B</i>
SBUF	Serial Buffer	99H									xxxxxxxB
AUXR0	Auxiliary Register 0	A1H	P40OC1	P40OC0	P40FD	GF	P1FS1	P1FS0	INT1H	INT0H	00000000B
AUXR1	Auxiliary Register 1	A2H	RTX3E	RTX2E	RTX1E	RTX0E	GF	GF	RXCS1	RXCS0	00000000B
AUXR2	Auxiliary Register 2	A3H	URXR	BTI	URM0X6	SMOD2	T1X12	T0X12	T1CKOE	T0CKOE	00000000B
<i>IE</i>	<i>Interrupt Enable</i>	<i>A8H</i>	<i>EA</i>	--	--	<i>ES</i>	<i>ET1</i>	<i>EX1</i>	<i>ET0</i>	<i>EX0</i>	<i>00000000B</i>
SADDR	Slave Address	A9H									00000000B
EIE1	Extended INT Enable 1	ADH	--	--	--	--	ESF	--	--	--	xxxx0xxxB
EIP1L	Ext. INT Priority 1 Low	AEH	--	--	--	--	PSFL	--	--	--	xxxx0xxxB
EIP1H	Ext. INT Priority 1 High	AFH	--	--	--	--	PSFH	--	--	--	xxxx0xxxB
<i>P3</i>	<i>Port 3</i>	<i>B0H</i>	<i>P3.7</i>	<i>P3.6</i>	<i>P3.5</i>	<i>P3.4</i>	<i>P3.3</i>	<i>P3.2</i>	<i>P3.1</i>	<i>P3.0</i>	<i>11111111B</i>
P3M0	P3 Mode Register 0	B1H	P3M0.7	P3M0.6	P3M0.5	P3M0.4	P3M0.3	P3M0.2	P3M0.1	P3M0.0	00000000B
P3M1	P3 Mode Register 1	B2H	P3M1.7	P3M1.6	P3M1.5	P3M1.4	P3M1.3	P3M1.2	P3M1.1	P3M1.0	00000000B
P4M0	P4 Mode Register 0	B3H	--	--	--	--	--	--	P4M0.1	P4M0.0	xxxxx00B
PUCON0	Pull-Up Control 0	92H	--	PU40	--	--	PU11	PU10	--	--	x0xx00xxB
IP0H	Interrupt Priority 0 High	B7H	--	--	--	PSH	PT1H	PX1H	PT0H	PX0H	00000000B
<i>IP0L</i>	<i>Interrupt Priority Low</i>	<i>B8H</i>	--	--	--	<i>PSL</i>	<i>PT1L</i>	<i>PX1L</i>	<i>PT0L</i>	<i>PX0L</i>	<i>00000000B</i>
SADEN	Slave Address Mask	B9H									00000000B
CKCON0	Clock Control 0	C7H	AFS	--	--	--	--	SCKS2	SCKS1	SCKS0	0xxx000B
<i>PSW</i>	<i>Program Status Word</i>	<i>D0H</i>	<i>CY</i>	<i>AC</i>	<i>F0</i>	<i>RS1</i>	<i>RS0</i>	<i>OV</i>	<i>F1</i>	<i>P</i>	<i>00000000B</i>
P3KBIE	P3 KBI Enable	D6H	P37KBIE	P36KBIE	P35KBIE	P34KBIE	P41KBIE	P40KBIE	P31KBIE	P30KBIE	00000000B
P1KBIE	P1 KBI Enable	D7H	P17KBIE	P16KBIE	P15KBIE	P14KBIE	P13KBIE	P12KBIE	P11KBIE	P10KBIE	00000000B
<i>ACC</i>	<i>Accumulator</i>	<i>E0H</i>	<i>ACC.7</i>	<i>ACC.6</i>	<i>ACC.5</i>	<i>ACC.4</i>	<i>ACC.3</i>	<i>ACC.2</i>	<i>ACC.1</i>	<i>ACC.0</i>	<i>00000000B</i>
WDTCR	Watch-dog-timer Control register	E1H	WREN	NSW	ENW	CLW	WIDL	PS2	PS1	PS0	0x000000B
IFD	ISP Flash data	E2H									11111111B
IFADRH	ISP Flash address High	E3H									00000000B
IFADRL	ISP Flash Address Low	E4H									00000000B
IFMT	ISP Mode Table	E5H	--	--	--	--	--	MS2	MS1	MS0	xxxxx000B
SCMD	ISP Serial Command	E6H									xxxxxxxB
ISPCR	ISP Control Register	E7H	ISPEN	BS	SRST	CFAIL	--	--	--	--	0000xxxxB
<i>P4</i>	<i>Port 4</i>	<i>E8H</i>	--	--	--	--	--	--	<i>P4.1</i>	<i>P4.0</i>	<i>xxxxxx11B</i>
<i>B</i>	<i>B Register</i>	<i>F0H</i>	<i>B.7</i>	<i>B.6</i>	<i>B.5</i>	<i>B.4</i>	<i>B.3</i>	<i>B.2</i>	<i>B.1</i>	<i>B.0</i>	<i>00000000B</i>

3.3. Auxiliary SFR Map (Page P)

MG86FE/L104 has an auxiliary SFR page which is indexed by page P and the SFRs' write is a different way from standard 8051 SFR page. The registers in auxiliary SFR map are addressed by IFMT and SCMD like ISP/IAP access flow. Page P has 256 bytes space that can target to **5** physical bytes and **4** logical bytes. The **5** physical bytes include IAPLB, CKCON2, PCON2, SPCON0 and DCON0. The **4** logical bytes include PCON0, PCON1, CKCON0 and WDTCR. Write on the **4** logical bytes gets the coherence content with the same SFR in Normal Page. Please refer Section "[18 Page P SFR Access](#)" for more detail information.

Table 3-3. Auxiliary SFR Map (Page P)

	0/8	1/9	2/A	3/B	4/C	5/D	6/E	7/F
F8	--							
F0								
E8	--							
E0		WDTCR						
D8								
D0								
C8								
C0								CKCON0
B8								--
B0								
A8								
A0								
98								
90								PCON1
88								
80								PCON0
78								
70								
68								
60								
58								
50								
48	SPCON0				DCON0			
40	CKCON2	--			PCON2	--		
38								
30								
28								
20								
18								
10								
08								
00	--	--	--	IAPLB	--	--	--	--
	0/8	1/9	2/A	3/B	4/C	5/D	6/E	7/F

3.4. Auxiliary SFR Bit Assignment (Page P)

Table 3–4. Auxiliary SFR Bit Assignment (Page P)

SYMBOL	DESCRIPTION	ADDR	BIT ADDRESS AND SYMBOL								RESET VALUE
			Bit-7	Bit-6	Bit-5	Bit-4	Bit-3	Bit-2	Bit-1	Bit-0	
IAPLB	IAP Low Boundary	03H	IAPLB6	IAPLB5	IAPLB4	IAPLB3	IAPLB2	IAPLB1	IAPLB0	--	IFR03
CKCON2	Clock Control 2	40H	0	0	XTALE	IHRCOE	0	0	OSCS1	OSCS0	xx01xx00B
PCON2	Power Control 2	44H	--	AWBOD0	--	--	--	--	BO0RE	1	x0xxxxx1B
SPCON0	SFR Page Control 0	48H	--	--	--	WRCTL	--	CKCTL0	PWCTL1	PWCTL0	xxx0x000B
DCON0	Device Control 0	4CH	HSE	IAPO	0	0	0	0	RSTIO	0	10xxxxxx

Sample Code of Page-P SFR write:

```

IFADRH = 0x00;
ISPCR = ISPEN;           //enable IAP/ISP
IFMT = MS2;             // Page-P write, IFMT =0x04
IFADRL = SPCON0;       //Set Page-P SFR address
IFD |= CKCTL0;         // set CKCTL0
SCMD = 0x46;           //
SCMD = 0xB9;           //
IFMT = Flash_Standby; // IAP/ISP standby, IFMT =0x00
ISPCR &= ~ISPEN;

```

4. Pin Configurations

4.1. Package Instruction

Figure 4–1. MG86FE/L104AS20 Top View

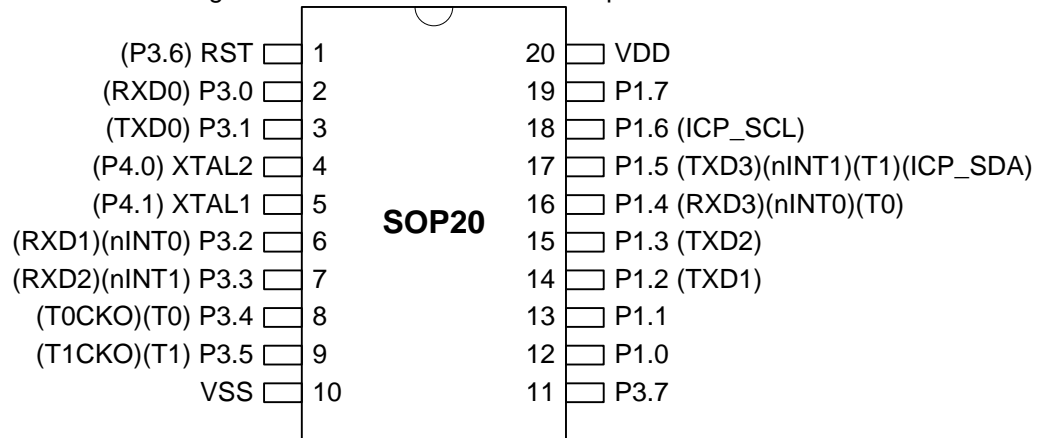

Figure 4–2. MG86FE/L104AS16 Top View

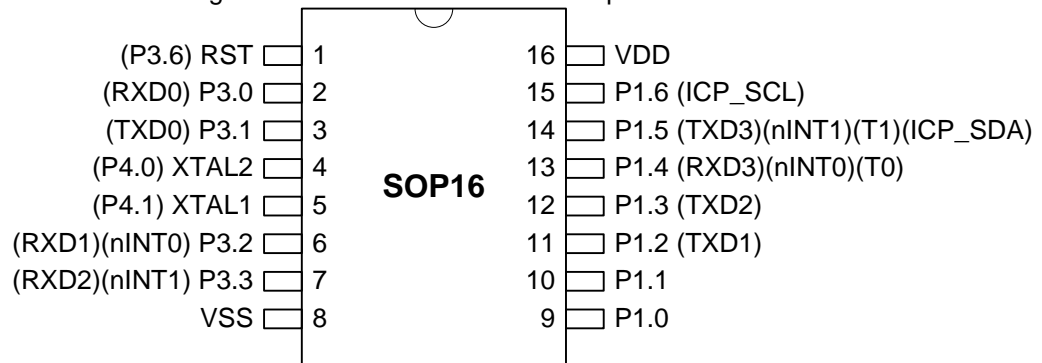
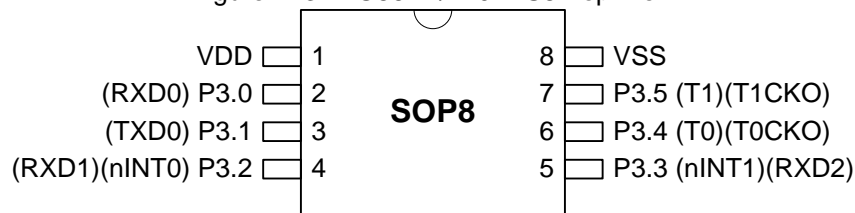

Figure 4–3. MG86FE/L104AS8 Top View



4.2. Pin Description

Table 4–1. Pin Description

MNEMONIC	PIN NUMBER			I/O TYPE	DESCRIPTION
	20-Pin SOP	16-Pin SOP	8-Pin SOP		
P1.0	12	9	--	I/O	* Port 1.0.
P1.1	13	10	--	I/O	* Port 1.1.
P1.2 (TXD1)	14	11	--	I/O	* Port 1.2. * TXD1: TXD channel 1 output of UART repeater.
P1.3 (TXD2)	15	12	--	I/O	* Port 1.3. * TXD2: TXD channel 2 output of UART repeater.
P1.4 (RXD3) (nINT0) (T0)	16	13	--	I/O	* Port 1.4. * RXD3: RXD channel 3 input of UART repeater. * nINT0: Alternate function for nINT0 input. * T0: Alternate function for T0 input.
P1.5 (TXD3) (nINT1) (T1) (ICP_SDA)	17	14	--	I/O	* Port 1.5. * TXD3: TXD channel 3 output of UART repeater. * nINT1: Alternate function for nINT1 input. * T1: Alternate function for T1 input. * ICP_SDA: Serial data of ICP interface.
P1.6 (ICP_SCL)	18	15	--	I/O	* Port 1.6. * ICP_SCL: Serial clock of ICP interface.
P1.7	19	--	--	I/O	* Port 1.7.
P3.0 (RXD0)	2	2	2	I/O	* Port 3.0. * RXD0: UART0 serial input port.
P3.1 (TXD0)	3	3	3	I/O	* Port 3.1. * TXD0: UART0 serial output port.
P3.2 (nINT0) (RXD1)	6	6	4	I/O	* Port 3.2. * nINT0: external interrupt 0 input. * RXD3: RXD channel 3 input of UART repeater.
P3.3 (nINT1) (RXD2)	7	7	5	I/O	* Port 3.3. * nINT1: external interrupt 1 input. * RXD3: RXD channel 3 input of UART repeater.
P3.4 (T0) (T0CKO)	8	--	6	I/O	* Port 3.4. * T0: Timer/Counter 0 external input. * T0CKO: programmable clock-out from Timer 0.
P3.5 (T1) (T1CKO)	9	--	7	I/O	* Port 3.5. * T1: Timer/Counter 1 external input. * T1CKO: programmable clock-out from Timer 1.
P3.7	11	--	--	I/O	* Port 3 bit-7.
P4.0 (CKO) (ECKI) (XTAL2)	4	4	--	I/O O I O	* Port 4.0. It is only accessed in SFR page "1". * CKO: Internal clock output. * ECKI: In external clock input mode, this is clock input pin. * XTAL2: Output of on-chip crystal oscillating circuit.
P4.1 (XTAL1)	5	5	--	I/O I	* Port 4.1. It is only accessed in SFR page "1". * XTAL1: Input of on-chip crystal oscillating circuit.
RST (P3.6)	1	1	--	I I/O	* RST: External RESET input, high active. * Port 3.6.
VDD	20	16	1	P	Power supply input. 5V input for E-type. 3.3V input for L-type.
VSS	10	8	8	G	Ground, 0 V reference.

5. 8051 CPU Function Description

5.1. CPU Register

PSW: Program Status Word

SFR Page = Normal

SFR Address = 0xD0

RESET = 0000-0000

7	6	5	4	3	2	1	0
CY	AC	F0	RS1	RS0	OV	F1	P
R/W	R/W	R/W	R/W	R/W	R/W	R/W	R/W

CY: Carry bit.

AC: Auxiliary carry bit.

F0: General purpose flag 0.

RS1: Register bank select bit 1.

RS0: Register bank select bit 0.

OV: Overflow flag.

F1: General purpose flag 1.

P: Parity bit.

The program status word(PSW) contains several status bits that reflect the current state of the CPU. The PSW, shown above, resides in the SFR space. It contains the Carry bit, the Auxiliary Carry(for BCD operation), the two register bank select bits, the Overflow flag, a Parity bit and two user-definable status flags.

The Carry bit, other than serving the function of a Carry bit in arithmetic operations, also serves as the “Accumulator” for a number of Boolean operations.

The bits RS0 and RS1 are used to select one of the four register banks shown in Section “6.2 On-Chip Data RAM”. A number of instructions refer to these RAM locations as R0 through R7.

The Parity bit reflects the number of 1s in the Accumulator. P=1 if the Accumulator contains an odd number of 1s and otherwise P=0.

SP: Stack Pointer

SFR Page = Normal

SFR Address = 0x81

RESET = 0000-0111

7	6	5	4	3	2	1	0
SP.7	SP.6	SP.5	SP.4	SP.3	SP.2	SP.1	SP.0
R/W	R/W	R/W	R/W	R/W	R/W	R/W	R/W

The Stack Pointer holds the location of the top of the stack. The stack pointer is incremented before every PUSH operation. The SP register defaults to 0x07 after reset.

DPL: Data Pointer Low

SFR Page = Normal

SFR Address = 0x82

RESET = 0000-0000

7	6	5	4	3	2	1	0
DPL.7	DPL.6	DPL.5	DPL.4	DPL.3	DPL.2	DPL.1	DPL.0
R/W	R/W	R/W	R/W	R/W	R/W	R/W	R/W

The DPL register is the low byte of the 16-bit DPTR. DPTR is used to access indirectly addressed XRAM and Flash memory.

DPH: Data Pointer High

SFR Page = Normal

SFR Address = 0x83

RESET = 0000-0000

7	6	5	4	3	2	1	0
DPH.7	DPH.6	DPH.5	DPH.4	DPH.3	DPH.2	DPH.1	DPH.0
R/W	R/W	R/W	R/W	R/W	R/W	R/W	R/W

The DPH register is the high byte of the 16-bit DPTR. DPTR is used to access indirectly addressed XRAM and Flash memory.

ACC: Accumulator

SFR Page = Normal

SFR Address = 0xE0 RESET = 0000-0000

7	6	5	4	3	2	1	0
ACC.7	ACC.6	ACC.5	ACC.4	ACC.3	ACC.2	ACC.1	ACC.0
R/W	R/W	R/W	R/W	R/W	R/W	R/W	R/W

This register is the accumulator for arithmetic operations.

B: B Register

SFR Page = Normal

SFR Address = 0xF0 RESET = 0000-0000

7	6	5	4	3	2	1	0
B.7	B.6	B.5	B.4	B.3	B.2	B.1	B.0
R/W	R/W	R/W	R/W	R/W	R/W	R/W	R/W

This register serves as a second accumulator for certain arithmetic operations.

5.2. CPU Timing

The **MG86FE/L104** is a single-chip microcontroller based on a high performance 1-T architecture 80C51 CPU that has an 8051 compatible instruction set, and executes instructions in 1~6 clock cycles (about 6~7 times the rate of a standard 8051 device). It employs a pipelined architecture that greatly increases its instruction throughput over the standard 8051 architecture. The instruction timing is different than that of the standard 8051.

In many 8051 implementations, a distinction is made between machine cycles and clock cycles, with machine cycles varying from 2 to 12 clock cycles in length. However, the 1T-80C51 implementation is based solely on clock cycle timing. All instruction timings are specified in terms of clock cycles. For more detailed information about the 1T-80C51 instructions, please refer Section “[23 Instruction Set](#)” which includes the mnemonic, number of bytes, and number of clock cycles for each instruction.

5.3. CPU Addressing Mode

Direct Addressing(DIR)

In direct addressing the operand is specified by an 8-bit address field in the instruction. Only internal data RAM and SFRs can be direct addressed.

Indirect Addressing(IND)

In indirect addressing the instruction specified a register which contains the address of the operand. Both internal and external RAM can be indirectly addressed.

The address register for 8-bit addresses can be R0 or R1 of the selected bank, or the Stack Pointer. The address register for 16-bit addresses can only be the 16-bit data pointer register – DPTR.

Register Instruction(REG)

The register banks, containing registers R0 through R7, can be accessed by certain instructions which carry a 3-bit register specification within the op-code of the instruction. Instructions that access the registers this way are code efficient because this mode eliminates the need of an extra address byte. When such instruction is executed, one of the eight registers in the selected bank is accessed.

Register-Specific Instruction

Some instructions are specific to a certain register. For example, some instructions always operate on the accumulator or data pointer, etc. No address byte is needed for such instructions. The op-code itself does it.

Immediate Constant(IMM)

The value of a constant can follow the op-code in the program memory.

Index Addressing

Only program memory can be accessed with indexed addressing and it can only be read. This addressing mode is intended for reading look-up tables in program memory. A 16-bit base register(either DPTR or PC) points to the base of the table, and the accumulator is set up with the table entry number. Another type of indexed addressing is used in the conditional jump instruction.

In conditional jump, the destination address is computed as the sum of the base pointer and the accumulator.

6. Memory Organization

Like all 80C51 devices, the **MG86FE/L104** has separate address spaces for program and data memory. The logical separation of program and data memory allows the data memory to be accessed by 8-bit addresses, which can be quickly stored and manipulated by the 8-bit CPU.

Program memory (ROM) can only be read, not written to. There can be up to 4K bytes of program memory. In the **MG86FE/L104**, all the program memory are on-chip Flash memory, and without the capability of accessing external program memory because of no External Access Enable (/EA) and Program Store Enable (/PSEN) signals designed.

Data memory occupies a separate address space from program memory. In the **MG86FE/L104**, there is only a 256 bytes of internal scratch-pad RAM and has no any expanded RAM(XRAM).

6.1. On-Chip Program Flash

Program memory is the memory which stores the program codes for the CPU to execute, as shown in [Figure 6–1](#). After reset, the CPU begins execution from location 0000H, where should be the starting of the user's application code. To service the interrupts, the interrupt service locations (called interrupt vectors) should be located in the program memory. Each interrupt is assigned a fixed location in the program memory. The interrupt causes the CPU to jump to that location, where it commences execution of the service routine. External Interrupt 0, for example, is assigned to location 0003H. If External Interrupt 0 is going to be used, its service routine must begin at location 0003H. If the interrupt is not going to be used, its service location is available as general purpose program memory.

The interrupt service locations are spaced at an interval of 8 bytes: 0003H for External Interrupt 0, 000BH for Timer 0, 0013H for External Interrupt 1, 001BH for Timer 1, etc. If an interrupt service routine is short enough (as is often the case in control applications), it can reside entirely within that 8-byte interval. Longer service routines can use a jump instruction to skip over subsequent interrupt locations, if other interrupts are in use.

Figure 6–1. Program Memory

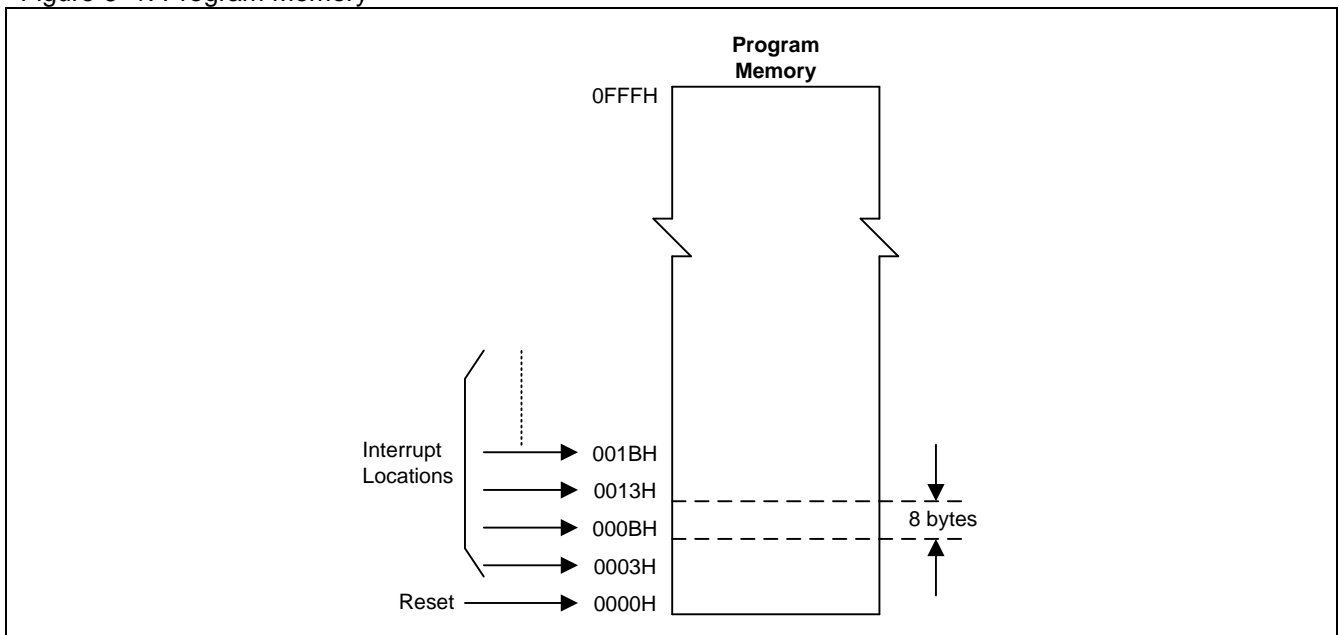

6.2. On-Chip Data RAM

Figure 6–2 shows the internal and external data memory spaces available to the **MG86FE/L104** user. Internal data memory can be divided into three blocks, which are generally referred to as the lower 128 bytes of RAM, the upper 128 bytes of RAM, and the 128 bytes of SFR space. Internal data memory addresses are always 8-bit wide, which implies an address space of only 256 bytes. Direct addresses higher than 7FH access the SFR space; and indirect addresses higher than 7FH access the upper 128 bytes of RAM. Thus the SFR space and the upper 128 bytes of RAM occupy the same block of addresses, 80H through FFH, although they are physically separate entities.

The lower 128 bytes of RAM are present in all 80C51 devices as mapped in Figure 6–3. The lowest 32 bytes are grouped into 4 banks of 8 registers. Program instructions call out these registers as R0 through R7. Two bits in the Program Status Word (PSW) select which register bank is in use. This allows more efficient use of code space, since register instructions are shorter than instructions that use direct addressing. The next 16 bytes above the register banks form a block of bit-addressable memory space. The 80C51 instruction set includes a wide selection of single-bit instructions, and the 128 bits in this area can be directly addressed by these instructions. The bit addresses in this area are 00H through 7FH.

All of the bytes in the Lower 128 can be accessed by either direct or indirect addressing while the Upper 128 can only be accessed by indirect addressing.

Figure 6–4 gives a brief look at the Special Function Register (SFR) space. SFRs include the Port latches, timers, peripheral controls, etc. These registers can only be accessed by direct addressing. Sixteen addresses in SFR space are both byte- and bit-addressable. The bit-addressable SFRs are those whose address ends in 0H or 8H.

Figure 6–2. Data Memory

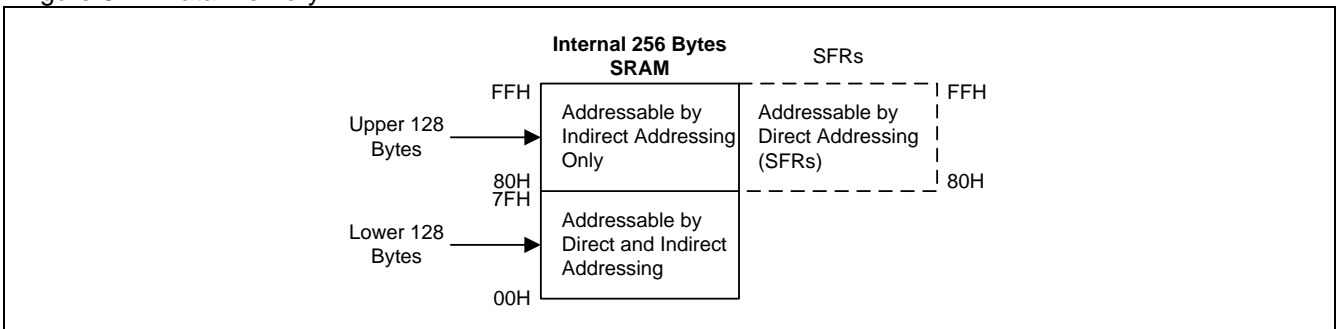

Figure 6–3. Lower 128 Bytes of Internal RAM

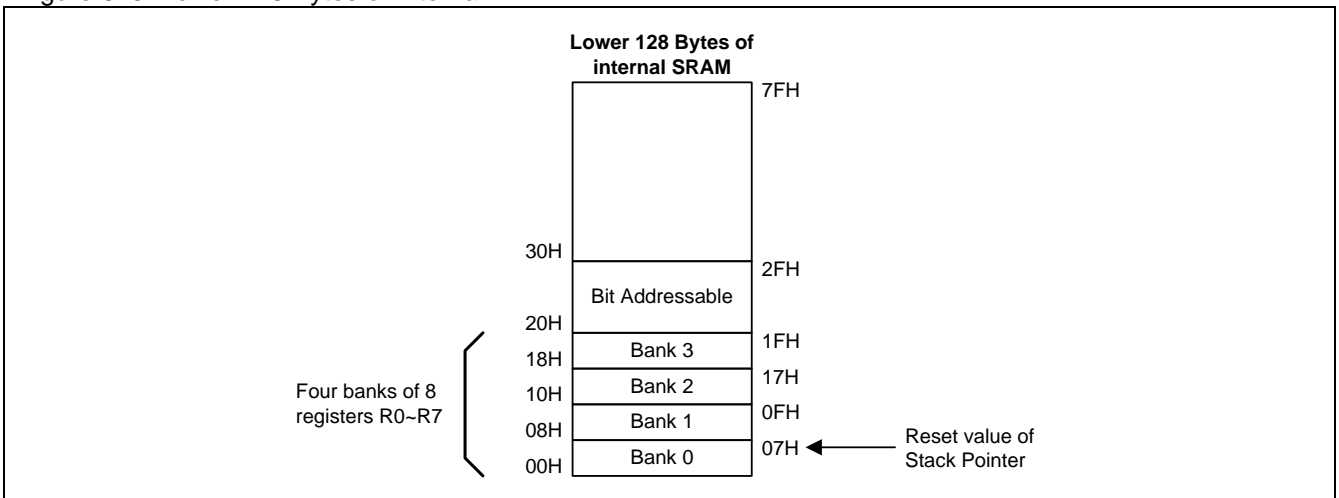
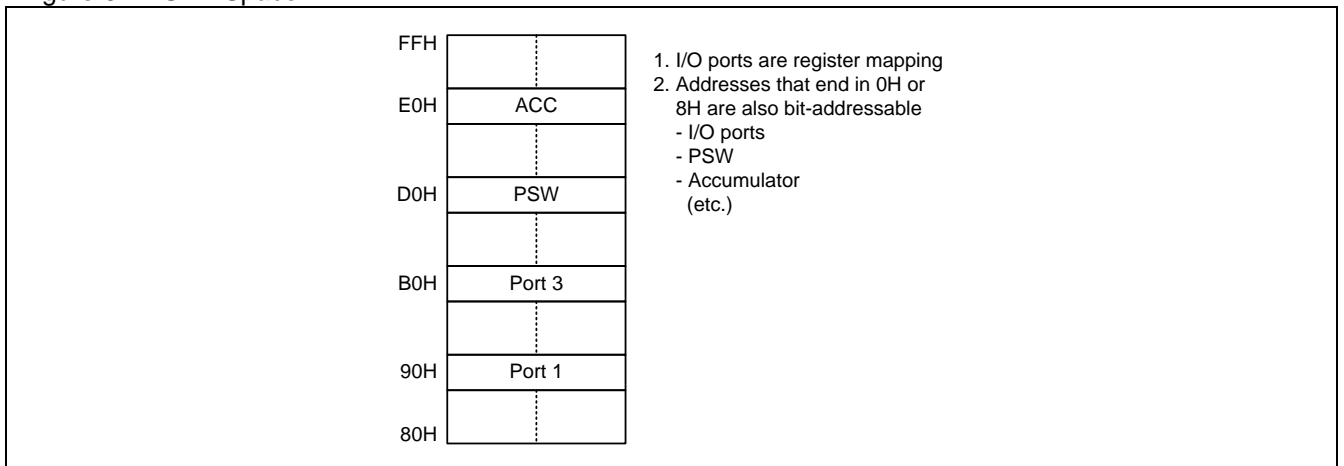

Figure 6-4. SFR Space



6.3. Declaration Identifiers in a C51-Compiler

The declaration identifiers in a C51-compiler for the various **MG86FE/L104** memory spaces are as follows:

data

128 bytes of internal data memory space (00h~7Fh); accessed via direct or indirect addressing, using instructions other than MOVX and MOVC. All or part of the Stack may be in this area.

idata

Indirect data; 256 bytes of internal data memory space (00h~FFh) accessed via indirect addressing using instructions other than MOVX and MOVC. All or part of the Stack may be in this area. This area includes the data area and the 128 bytes immediately above it.

sfr

Special Function Registers; CPU registers and peripheral control/status registers, accessible only via direct addressing.

xdata

There is no on-chip XRAM or XRAM interface for ***xdata*** access.

pdata

There is no on-chip XRAM or XRAM interface for ***pdata*** access.

code

4K bytes of program memory space; accessed as part of program execution and via the "MOVC @A+DTPR" instruction.

7. Data Pointer Register (DPTR)

There is only one set DPTR in **MG86FE/L104**. And **MG86FE/L104** does not support external memory access and MOVX instruction.

8. System Clock

There are four clock sources for the system clock: Internal High-frequency RC Oscillator (IHRCO), external crystal oscillator, Internal Low-frequency RC Oscillator (ILRCO) and External Clock Input. Figure 8–1 shows the structure of the system clock in **MG86FE/L104**.

The **MG86FE/L104** always boots from IHRCO on 24MHz with divided 2 on system clock and reserves crystal pads as P4.0/P4.1 GPIO function. Software can select the one of the four clock sources by application required and switches them on the fly. But software needs to settle the clock source stably before clock switching. If software selects external crystal mode, port pin of P4.0 and P4.1 will be assigned to XTAL2 and XTAL1. And P4.0/P4.1 GPIO function will be inhibited. In external clock input mode (ECKI), the clock source comes from P4.0 input and P4.1 still serves the GPIO function.

The built-in IHRCO provides two kinds of frequency for software selected. Another frequency is 22.118MHz by software setting AFS on CKCON0.7. Both of 24MHz and 22.118 MHz in IHRCO provide high precision frequency with $\pm 4\%$ deviation over all operating voltage and temperature. In IHRCO or ILRCO mode, P4.0 can be configured to internal OSCin output or OSCin/2 and OSCin/4 for system application.

The system clock, SYSClk, is obtained from one of these four clock sources through the clock divider, as shown in Figure 8–1. The user can program the divider control bits SCKS2–SCKS0 (in CKCON0 register) to get the desired system clock. The default system clock divider is set to “/2” in **MG86FE/L104** after power on or reset.

8.1. Clock Structure

Figure 8–1 presents the principal clock systems in the **MG86FE/L104**. The system clock can be sourced by the external oscillator circuit or either internal oscillator.

Figure 8–1. System Clock

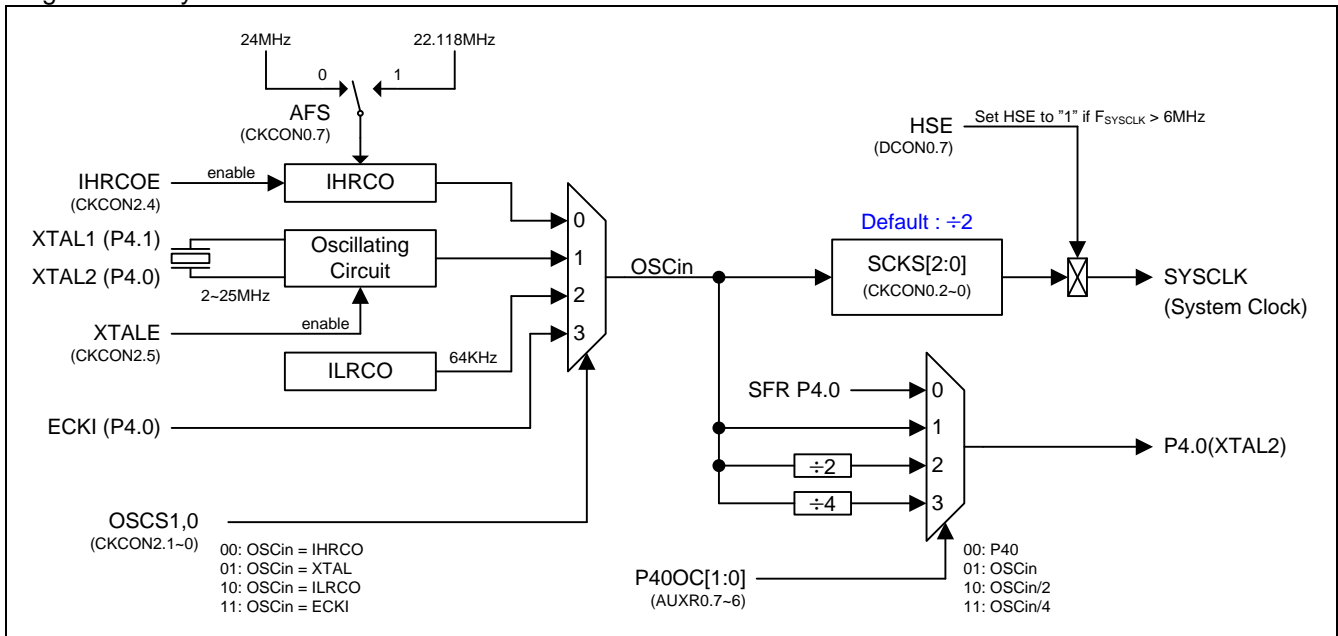

8.2. Clock Register

CKCON0: Clock Control Register 0

SFR Page = Normal & Page P

SFR Address = 0xC7

RESET = 0xxx-x001

7	6	5	4	3	2	1	0
AFS	0	0	0	0	SCKS2	SCKS1	SCKS0
R/W	W	W	W	W	R/W	R/W	R/W

Bit 7: AFS, Alternated Frequency Selection.

0: Select IHRCO to output 24MHz.

1: Select IHRCO to output 22.118MHz.

Bit 6~3: Reserved. Software must write “0” on these bits when CKCON0 is written.

Bit 2~0: SCKS2 ~ SCKS0, programmable System Clock Selection. The default value of SCKS[2:0] is set to “001” to select system clock on OSCin/2.

SCKS[2:0]	System Clock
0 0 0	OSCin
0 0 1	OSCin /2 (default setting)
0 1 0	OSCin /4
0 1 1	OSCin /8
1 0 0	OSCin /16
1 0 1	OSCin /32
1 1 0	OSCin /64
1 1 1	OSCin /128

CKCON2: Clock Control Register 2

SFR Page = Page P Only

SFR Address = 0x40

RESET = xx01-xx00

7	6	5	4	3	2	1	0
0	0	XTALE	IHRCOE	0	0	OSCS1	OSCS0
W	W	R/W	R/W	W	W	R/W	R/W

Bit 7~6: Reserved. Software must write “0” on these bits when CKCON2 is written.

Bit 5: XTALE, external Crystal (XTAL) Enable. The default value is set by hardware option on clock source selection.

0: Disable XTAL oscillating circuit. In this case, XTAL2 and XTAL1 behave as Port 4.0 and Port 4.1.

1: Enable XTAL oscillating circuit. If this bit is set by CPU software, it needs **3 ms** to have stable output after XTALE enabled.

Bit 4: IHRCOE, Internal High frequency RC Oscillator Enable.

0: Disable internal high frequency RC oscillator.

1: Enable internal high frequency RC oscillator. If this bit is set by CPU software, it needs **32 us** to have stable output after IHRCOE enabled.

Bit 3~2: Reserved. Software must write “0” on these bits when CKCON2 is written.

Bit 1~0: OSCS[1:0], OSCin source selection. The default selection of OSCin is IHRCO.

OSCS[1:0]	OSCin source Selection
0 0	IHRCO
0 1	XTAL
1 0	ILRCO
1 1	ECKI, External Clock Input (P4.0) as OSCin.

AUXR0: Auxiliary Register 0

SFR Page = Normal

SFR Address = 0xA1

RESET = 000x-0000

7	6	5	4	3	2	1	0
P40OC1	P40OC0	P40FD	--	P1FS1	P1FS0	INT1H	INT0H
R/W	R/W	R/W	W	R/W	R/W	R/W	R/W

Bit 7~6: P4.0 function configured control bit 1 and 0. The two bits only act when internal RC oscillator (IHRCO or ILRCO) is selected for system clock source. In crystal mode, XTAL2 and XTAL1 are the alternated function for P4.0 and P4.1. In external clock input mode, P4.0 is the dedicated clock input pin. In internal oscillator condition, P4.0 provides the following selections for GPIO or clock source generator. When P40OC[1:0] index to non-P4.0 GPIO function, P4.0 will drive the on-chip RC oscillator (IHRCO or ILRCO) output to provide the clock source for other devices.

P40OC[1:0]	P4.0 function	P4.0 I/O mode
00	P40	By P4M0.0
01	OSCin	By P4M0.0
10	OSCin/2	By P4M0.0
11	OSCin/4	By P4M0.0

For clock-out on P4.0 function, it is recommended to set P4M0.0 to "1" which selects P4.0 as push-push output mode.

Bit 5: P40FD, P4.0 Fast Driving.

0: P4.0 output with default driving.

1: P4.0 output with fast driving enabled. If P4.0 is configured to clock output, enable this bit when P4.0 output frequency is more than 12MHz at 5V application or more than 6MHz at 3V application.

DCON0: Device Control 0

SFR Page = Page P only

SFR Address = 0x4C

RESET = 10xx-xx1x

7	6	5	4	3	2	1	0
HSE	IAPO	0	0	0	0	RSTIO	0
W	W	W	W	W	W	W	W

Bit 7: HSE, High Speed operation Enable.

0: Select MCU running in low speed mode which is slow down internal circuit to reduce power consumption.

1: Enable MCU full speed operation if $F_{SYSCLK} > 6\text{MHz}$.

8.3. Clock Sample Code

(1) Required function: Switch IHRCO from default 24MHz to 22.118MHz

Assembly Code Example:	
ORL CKCON0,#(AFS)	; Select IHRCO to output 22.118MHz
C Code Example:	
CKCON0 = AFS;	// Select IHRCO to output 22.1184MHz.

(2). Required Function: Switch SYSCLK to OSCin/1 (default is OSCin/2)

Assembly Code Example:	
ANL CKCON0,#(AFS)	; Set SCKS[2:0] = 0 to select OSCin/1
C Code Example:	
CKCON0 &= ~(SCKS2 SCKS1 SCKS0);	// System clock divider /1 // SCKS[2:0], system clock divider // 0 OSCin/1 // 1 OSCin/2 // 2 OSCin/4 // 3 OSCin/8 // 4 OSCin/16 // 5 OSCin/32 // 6 OSCin/64 // 7 OSCin/128

(3). Required Function: Select XTAL as OSCin source when MCU using IHRCO or ILRCO (default is IHRCO)

Assembly Code Example:	
MOV IFADRL,#(CKCON2)	; Index Page-P address to CKCON2
CALL _page_p_sfr_read	; Read CKCON2 data
ORL IFD,#(XTALE)	; Enable XTALE
CALL _page_p_sfr_write	; Write data to CKCON2, SYSCLK must be less than 25MHz
check_XTOR:	; Check XTAL oscillating ready
MOV A,AUXR1	
JNB ACC.4,check_XTOR	; Waiting for XTOR(AUXR1.4) true
ANL IFD,#~(OSCS1 OSCS0)	; Switch OSCin source to XTAL.
ORL IFD,#(OSCS0)	
CALL _page_p_sfr_write	; Write data to CKCON2
ANL IFD,#~(IHRCOE)	; Disable IHRCO if MCU is switched from IHRCO
CALL _page_p_sfr_write	; Write data to CKCON2
C Code Example:	
IFADRL = CKCON2;	// Index Page-P address to CKCON2
page_p_sfr_read();	// Read CKCON2 data
IFD = XTALE;	// Enable XTALE
page_p_sfr_write ();	// Write data to CKCON2, SYSCLK must be less than 25MHz
while(AUXR1 & XTOR == 0x00);	// Check XTAL oscillating ready // Waiting for XTOR(AUXR1.4) true
IFD &= ~(OSCS1 OSCS0);	// Switch OSCin source to XTAL.

```

IFD |= OSCS0;
page_p_sfr_write ();           // Write data to CKCON2

IFD &= ~IHRCOE;
page_p_sfr_write();           // Disable IHRCO if MCU is switched from IHRCO
                               // Write data to CKCON2

```

(4). Required Function: Select ILRCO as OSCin source when MCU using IHRCO, ECKI or XTAL (default is IHRCO)

Assembly Code Example:

```

MOV    IFADRL,#(CKCON2)       ; Index Page-P address to CKCON2
CALL   _page_p_sfr_read       ; Read CKCON2 data

ANL    IFD,#~(OSCS1 | OSCS0)   ; Switch OSCin source to ILRCO
ORL    IFD,#(OSCS1)
CALL   _page_p_sfr_write      ; Write data to CKCON2

ANL    IFD,#~(XTALE | IHRCOE)  ; Disable XTAL and IHRCO
CALL   _page_p_sfr_write      ; Write data to CKCON2

MOV    IFADRL,#(DCON0)        ; Index Page-P address to DCON0
CALL   _page_p_sfr_read       ; Read DCON0 data

ANL    IFD,#~(HSE)            ; Disable HSE when SYSCLK ≤ 6MHz for power saving
CALL   _page_p_sfr_write      ; Write data to DCON0

```

C Code Example:

```

IFADRL = CKCON2;              // Index Page-P address to CKCON2
page_p_sfr_read();           // Read CKCON2 data.

IFD = ~(OSCS1 | OSCS0);      // Switch OSCin source to ILRCO
IFD |= OSCS1;
page_p_sfr_write();          // Write data to CKCON2

IFD &= ~(XTALE | IHRCOE);    // Disable XTAL and IHRCO
page_p_sfr_write();          // Write data to CKCON2

IFADRL = DCON0;              // Index Page-P address to DCON0
page_p_sfr_read();           // Read DCON0 data

IFD &= ~HSE;                  // Disable HSE when SYSCLK ≤ 6MHz for power saving
page_p_sfr_write();          // Write data to DCON0

```

(5). Required Function: Select ECKI as OSCin source when MCU using IHRCO or ILRCO (default is IHRCO)

Assembly Code Example:

```

MOV    IFADRL,#(CKCON2)       ; Index Page-P address to CKCON2
CALL   _page_p_sfr_read       ; Read CKCON2 data

ORL    IFD,#(OSCS1 | OSCS0)   ; Switch OSCin source to ECKI
CALL   _page_p_sfr_write      ; Write data to CKCON2, SYSCLK must be less than 25MHz

ANL    IFD,#~(XTALE | IHRCOE)  ; Disable IHRCO & XTAL
CALL   _page_p_sfr_write      ; Write data to CKON2

```

C Code Example:

```

IFADRL = CKCON2;              // Index Page-P address to CKCON2
page_p_sfr_read();           // Read CKCON2 data.

IFD |= OSCS1 | OSCS0;        // Switch OSCin source to ECKI
page_p_sfr_write ();         // Write data to CKCON2, SYSCLK must be less than 25MHz

```

```
IFD &= ~(XTALE | IHRCOE);           //Disable IHRCO and XTAL
page_p_sfr_write ();                // Write data to CKCON2
```

(6). Required Function: Select IHRCO as OSCin source when MCU using ILRCO, ECKI or XTAL

Assembly Code Example:

```
MOV    IFADRL,#(CKCON2)             ; Index Page-P address to CKCON2
CALL   _page_p_sfr_read              ; Read CKCON2 data

ORL    IFD,#(IHRCOE)                ; Enable IHRCO
CALL   _page_p_sfr_write             ; Write data to CKCON2

Delay_32us

ANL    IFD,#~(OSCS1 | OSCS0)        ; Switch OSCin source to IHRCO
CALL   _page_p_sfr_write             ; Write data to CKCON2

ANL    IFD,#~(XTALE)                ; Disable XTAL
CALL   _page_p_sfr_write             ; Write data to CKCON2
```

C Code Example:

```
IFADRL = CKCON2;                    // Index Page-P address to CKCON2
page_p_sfr_read();                  // Read CKCON2 data.

IFD |= IHRCOE;                      // Enable IHRCO
page_p_sfr_write();                 // Write data to CKCON2

Delay 32us

IFD &= ~(OSCS1 | OSCS0);             // Switch OSCin source to IHRCO
page_p_sfr_write();                 // Write data to CKCON2

IFD &= ~ XTALE;                     // Disable XTAL
page_p_sfr_write();                 // Write data to CKCON2
```

(7). Required Function: Output IHRCO frequency on P4.0

Assembly Code Example:

```
MOV    P4M0,#P4M00                  ; Set P4.0 to push-pull output mode
ANL    AUXR0,#~(P40OC1|P40OC0)      ; Switch P4.0 to GPIO function
ORL    AUXR0,#(P40OC0|P4FD)         ; P4.0 = IHRCO Frequency + Pin fast driving
                                           ; P40OC[1:0] | P4.0
                                           ; 00      | GPIO
                                           ; 01      | IHRCO/1
                                           ; 10      | IHRCO/2
                                           ; 11      | IHRCO/4
```

C Code Example:

```
P4M0 |= P4M00;                      // P4.0 select push-pull output mode.
AUXR0 &= ~(P40OC0 | P40OC1);        // Switch P4.0 to GPIO function
AUXR0 |= (P40OC0 | P4FD);           // P4.0 output IHRCO/1
// AUXR0 = P40OC1|P4FD;              // P4.0 output IHRCO/2
// AUXR0 = P40OC1|P40OC0|P4FD;      // P4.0 output IHRCO/4
```

9. Watch Dog Timer (WDT)

9.1. WDT Structure

The Watch-dog Timer (WDT) is intended as a recovery method in situations where the CPU may be subjected to software upset. The WDT consists of a 9-bit free-running counter, a 7-bit prescaler and a control register (WDTCR). [Figure 9–1](#) shows the WDT structure in **MG86FE/L104**.

When WDT is enabled, it derives its time base from the 64KHz ILRCO. The WDT overflow will set the WDTF on PCON1.0 which can be configured to generate an interrupt by enabled WDTFIE (SFIE.0) and enabled ESF (EIE1.3). The overflow can also trigger a system reset when WREN (WDTCR.7) is set. To prevent WDT overflow, software needs to clear it by writing “1” to the CLRW bit (WDTCR.4) before WDT overflows.

Note: the WDTFIE function is under verifying.

Once the WDT is enabled by setting ENW bit, there is no way to disable it except through power-on reset or page-p SFR over-write on ENW, which will clear the ENW bit. The WDTCR register will keep the previous programmed value unchanged after hardware (RST-pin) reset, software reset and WDT reset.

WREN, NSW and ENW are implemented to one-time-enabled function, only writing “1” valid in general SFR page. Page-P SFR Access on WDTCR can disable WREN, NSW and ENW, writing “0” on WDTCR.7~5. Please refer Section “[9.3 WDT Register](#)” and Section “[18 Page P SFR Access](#)” for more detail information.

Figure 9–1. Watch Dog Timer

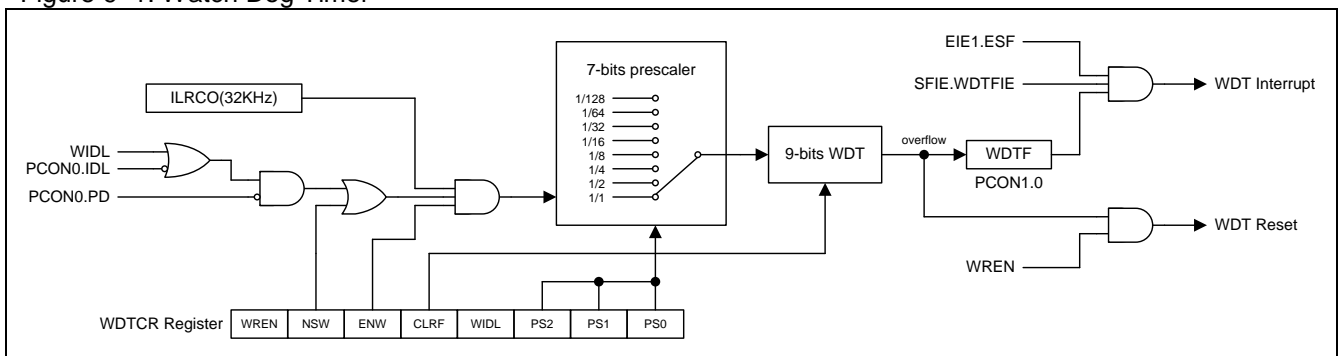

9.2. WDT During Idle and Power Down

In the Idle mode, the WIDL bit (WDTCR.3) determines whether WDT counts or not. Set this bit to let WDT keep counting in the Idle mode. If the hardware option WDTRCO is enabled, the WDT always keeps counting regardless of WIDL bit.

In the Power down mode, the ILRCO won't stop if the NSW (WDTCR.6) is enabled. That lets WDT keep counting even in Power down mode (Watch Mode). After WDT overflows, it will wake up the CPU from interrupt or reset by software configured.

9.3. WDT Register

WDTCR: Watch-Dog-Timer Control Register

SFR Page = Normal & Page P

SFR Address = 0xE1

POR = 0000-0111 (xxx0_xxxx by Hardware Option)

7	6	5	4	3	2	1	0
WREN	NSW	ENW	CLRW	WIDL	PS2	PS1	PS0
R/W	R/W	R/W	R/W	R/W	R/W	R/W	R/W

Bit 7: WREN, WDT Reset Enable. The initial value can be changed by hardware option, WRENO.

0: The overflow of WDT does not set the WDT reset. The WDT overflow flag, WDTF, may be polled by software or trigger an interrupt.

1: The overflow of WDT will cause a system reset. Once WREN has been set, it can not be cleared by software in page 0~F. **In page P, software can modify it to “0” or “1”.**

Bit 6: NSW. Non-Stopped WDT. The initial value can be changed by hardware option, NSWDT.

0: WDT stop counting while the MCU is in power-down mode.

1: WDT always keeps counting while the MCU is in power-down mode (Watch Mode) or idle mode. Once NSW has been set, it can not be cleared by software in general page. **In page P, software can modify it to “0” or “1”.**

Bit 5: ENW. Enable WDT.

0: Disable WDT running. This bit is only cleared by POR.

1: Enable WDT while it is set. Once ENW has been set, it can not be cleared by software in general page. **In Page P, software can modify it as “0” or “1”.**

Bit 4: CLRW. Clear WDT counter.

0: Hardware will automatically clear this bit.

1: Clear WDT to recount while it is set.

Bit 3: WIDL. WDT idle control.

0: WDT stops counting while the MCU is in idle mode.

1: WDT keeps counting while the MCU is in idle mode.

Bit 2~0: PS2 ~ PS0, select prescaler output for WDT time base input.

PS[2:0]	Prescaler Value	WDT Period
0 0 0	1	15 ms
0 0 1	2	31 ms
0 1 0	4	62 ms
0 1 1	8	124 ms
1 0 0	16	248 ms
1 0 1	32	496 ms
1 1 0	64	992 ms
1 1 1	128	1.984 S

PCON1: Power Control Register 1

SFR Page = Normal & Page P

SFR Address = 0x97

POR = 0010-0x00

7	6	5	4	3	2	1	0
SWRF	EXRF	--	--	KBIF	--	BOF0	WDTF
R/W	R/W	W	W	R/W	W	R/W	R/W

Bit 0: WDTF, WDT overflow flag.

0: This bit must be cleared by software writing “1” on it. Software writing “:0” is no operation.

1: This bit is only set by hardware when WDT overflows. Writing “1” on this bit will clear WDTF.

9.4. WDT Hardware Option

In addition to being initialized by software, the WDTCR register can also be automatically initialized at power-up by the hardware options WRENO, NSWDT, HWENW, HWWIDL and HWPS[2:0], which should be programmed by a universal Writer or Programmer, as described below.

If HWENW is programmed to “enabled”, then hardware will automatically do the following initialization for the WDTCR register at power-up: (1) set ENW bit, (2) load WRENO into WREN bit, (3) load NSWDT into NSW bit, (4) load HWWIDL into WIDL bit, and (5) load HWPS[2:0] into PS[2:0] bits.

If both of HWENW and WDSFWP are programmed to “enabled”, hardware still initializes the WDTCR register content by WDT hardware option at power-up. Then, any CPU writing on WDTCR bits will be inhibited except writing “1” on WDTCR.4 (CLR_W), clear WDT, even though access through Page-P SFR mechanism.

WRENO:

- : Enabled. Set WDTCR.WREN to enable a system reset function by WDTF.
- : Disabled. Clear WDTCR.WREN to disable the system reset function by WDTF.

NSWDT: Non-Stopped WDT

- : Enabled. Set WDTCR.NSW to enable the WDT running in power down mode (watch mode).
- : Disabled. Clear WDTCR.NSW to disable the WDT running in power down mode (disable Watch mode).

HWENW: Hardware loaded for “ENW” of WDTCR.

- : Enabled. Enable WDT and load the content of WRENO, NSWDT, HWWIDL and HWPS2~0 to WDTCR after power-on.
- : Disabled. WDT is not enabled automatically after power-on.

HWWIDL, HWPS2, HWPS1, HWPS0:

When HWENW is enabled, the content on these four fused bits will be loaded to WDTCR SFR after power-on.

WDSFWP:

- : Enabled. The WDT SFRs, WREN, NSW, WIDL, PS2, PS1 and PS0 in WDTCR, will be write-protected.
- : Disabled. The WDT SFRs, WREN, NSW, WIDL, PS2, PS1 and PS0 in WDTCR, are free for writing of software.

9.5. WDT Sample Code

(1) Required function: Enable WDT and select WDT period to 248ms

Assembly Code Example:	
ANL	PCON1,#(WDTF) ; Clear WDTF flag (write "1")
MOV	WDTCR,#(ENW CLRW PS2) ; Enable WDT counter and set WDT period to 248ms
C Code Example:	
PCON1 &= WDTF;	// Clear WDT flag (write "1")
WDTCR = (ENW CLRW PS2);	// Enable WDT counter and set WDT period to 248ms
	// PS[2:0] WDT period selection
	// 0 15ms
	// 1 31ms
	// 2 62ms
	// 3 124ms
	// 4 248ms
	// 5 496ms
	// 6 992ms
	// 7 1.984s

(2) Required function: How to Disable WDT

Assembly Code Example:	
MOV	IFD,WDTCR ; Read WDTCR data
ANL	IFD,#~(ENW) ; Clear ENW to disable WDT
MOV	IFADRL,#(WDTCR_P) ; Index Page-P address to WDTCR_P
CALL	_page_p_sfr_write ; Write data to WDTCR
C Code Example:	
IFD = WDTCR;	// Read WDTCR data
IFD &= ~ENW;	// Clear ENW to disable WDT
IFADRL = WDTCR_P;	// Index Page-P address to WDTCR_P
page_p_sfr_write();	// Write data to WDTCR

(3). Required Function: Enable WDT reset function and select WDT period to 62ms

Assembly Code Example:	
ANL	PCON1,#(WDTF) ; Clear WDTF flag (write "1")
MOV	WDTCR,#(WREN CLRW PS1) ; Enable WDT reset function and set WDT period to 62ms
ORL	WDTCR,#(ENW) ; Enable WDT counter, WDT running
C Code Example:	
PCON1 &= WDTF;	// Clear WDTF flag (write "1")
WDTCR = WREN CLRW PS1;	// Enable WDT reset function and set WDT period to 62ms
WDTCR = ENW;	// Enable WDT counter, WDT running.

(4). Required Function: Enable protected write for WDTCR

Assembly Code Example:

```
ANL   PCON1,#(WDTF)           ; Clear WDTF flag (write "1")
MOV   WDTCR,#(ENW | CLRW | PS2) ; Enable WDT counter and set WDT period to 248ms

MOV   IFADRL,#(SPCON0)        ; Index Page-P address to SPCON0
CALL  _page_p_sfr_read        ; Read SPCON0 data

ORL   IFD,#(WRCTL)            ; Enable protected write for WDTCR
CALL  _page_p_sfr_write       ; Write data to SPCON0

MOV   IFD,WDTCR               ; Read WDTCR data
ORL   IFD,#(CLRW)             ; Enable CLRW

MOV   IFADRL,#(WDTCR_P)       ; Index Page-P address to WDTCR_P
CALL  _page_p_sfr_write       ; Write data to WDTCR to clear WDT counter
```

C Code Example:

```
PCON1 &= WDTF;                // Clear WDTF flag (write "1")
WDTCR = ENW | CLRW | PS2;     // Enable WDT counter and set WDT period to 248ms

IFADRL = SPCON0;              // Index Page-P address to SPCON0
page_p_sfr_read();           // Read SPCON0 data

IFD |= WRCTL;                 // Enable protected write for WDTCR
page_p_sfr_write();          // Write data to SPCON0

IFD = WDTCR;                  // Read WDTCR data
IFD |= CLRW;                  // Enable CLRW

IFADRL = WDTCR_P;            // Index Page-P address to WDTCR_P
page_p_sfr_write();          // Write data to WDTCR to clear WDT counter
```

10. System Reset

During reset, all I/O Registers are set to their initial values, and the program starts execution from the Reset Vector, 0000H, or ISP start address by OR setting. The **MG86FE/L104** has six sources of reset: power-on reset, external reset, software reset, illegal address reset, WDT reset and brown-out reset. Figure 10–1 shows the system reset source in **MG86FE/L104**.

The following sections describe the reset happened source and corresponding control registers and indicating flags.

10.1. Reset Source

Figure 10–1 presents the reset systems in the **MG86FE/L104** and all of its reset sources.

Figure 10–1. System Reset Source

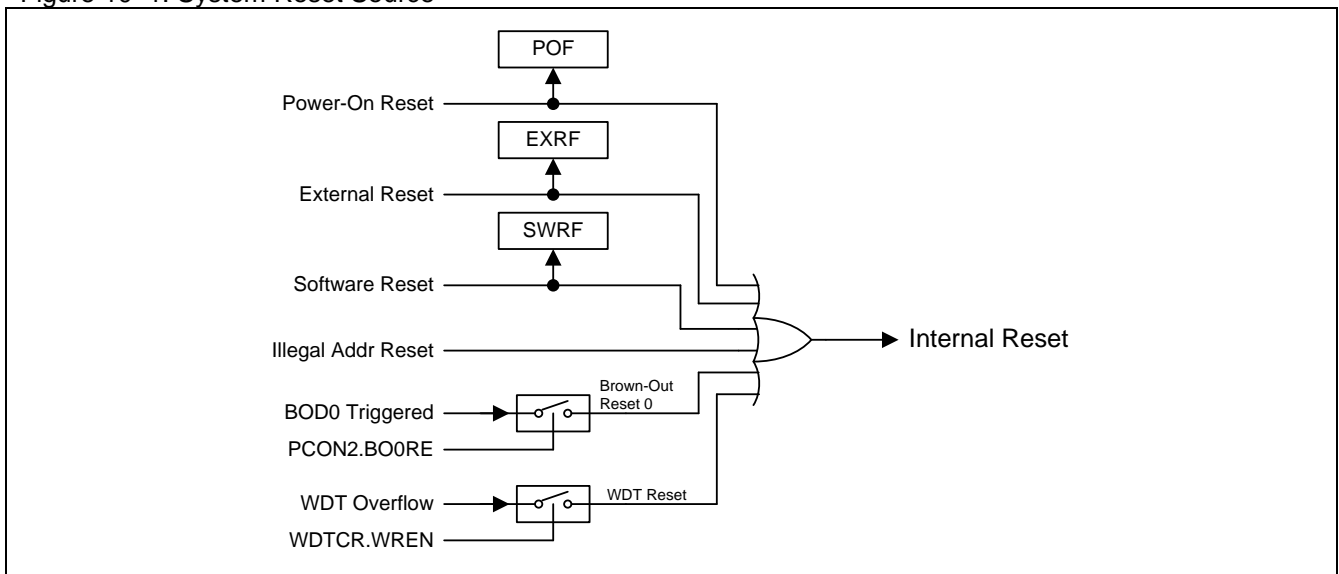

10.2. Power-On Reset

Power-on reset (POR) is used to internally reset the CPU during power-up. The CPU will keep in reset state and will not start to work until the VDD power rises above the voltage of Power-On Reset. And, the reset state is activated again whenever the VDD power falls below the POR voltage. During a power cycle, VDD must fall below the POR voltage before power is reapplied in order to ensure a power-on reset

PCON0: Power Control Register 0

SFR Page = Normal & Page P

SFR Address = 0x87

POR = 0001-0000, RESET = 000X-0000

7	6	5	4	3	2	1	0
SMOD1	SMOD0	GF	POF	GF1	GF0	PD	IDL
R/W	R/W	R/W	R/W	R/W	R/W	R/W	R/W

Bit 4: POF. Power-On Flag.

0: The flag must be cleared by software to recognize next reset type.

1: Set by hardware when VDD rises from 0 to its nominal voltage. POF can also be set by software.

The Power-on Flag, POF, is set to “1” by hardware during power up or when VDD power drops below the POR voltage. It can be clear by firmware and is not affected by any warm reset such as external reset, Brown-Out reset, software reset (ISPCR.5) and WDT reset. It helps users to check if the running of the CPU begins from power up or not. Note that the POF must be cleared by firmware.

10.3. External Reset

A reset is accomplished by holding the RESET pin HIGH for at least 24 oscillator periods while the oscillator is running. To ensure a reliable power-up reset, the hardware reset from RST pin is necessary.

PCON1: Power Control Register 1

SFR Page = Normal & Page P

SFR Address = 0x97 POR = 0010-0x00

7	6	5	4	3	2	1	0
SWRF	EXRF	--	--	KBIF	--	BOF0	WDTF
R/W	R/W	W	W	R/W	W	R/W	R/W

Bit 6: EXRF, External Reset Flag.

0: This bit must be cleared by software writing “1” on it. Software writing “:0” is no operation.

1: This bit is only set by hardware if an External Reset occurs. Writing “1” on this bit will clear EXRF.

10.4. Software Reset

Software can trigger the CPU to restart by software reset, writing “1” on SWRST (ISPCR.5), and set the SWRF flag (PCON1.7). SWBS decides the CPU is boot from ISP or AP region after the reset action

ISPCR: ISP Control Register

SFR Page = Normal

SFR Address = 0xE5 RESET = 0000-xxxx

7	6	5	4	3	2	1	0
ISPEN	SWBS	SWRST	CFAIL	-	--	--	--
R/W	R/W	R/W	R/W	W	W	W	W

Bit 6: SWBS, software boot selection control.

0: Boot from AP-memory after reset.

1: Boot from ISP memory after reset.

Bit 5: SWRST, software reset trigger control.

0: No operation

1: Generate software system reset. It will be cleared by hardware automatically.

PCON1: Power Control Register 1

SFR Page = Normal & Page P

SFR Address = 0x97 POR = 0010-0x00

7	6	5	4	3	2	1	0
SWRF	EXRF	--	--	KBIF	--	BOF0	WDTF
R/W	R/W	W	W	R/W	W	R/W	R/W

Bit 7: SWRF, Software Reset Flag.

0: This bit must be cleared by software writing “1” on it. Software writing “0” is no operation.

1: This bit is only set by hardware if a Software Reset occurs. Writing “1” on this bit will clear SWRF.

10.5. Illegal Address Reset

In **MG86FE/L104**, if software program runs to illegal address such as over program ROM limitation, it triggers a RESET to CPU.

10.6. Brown-Out Reset

In **MG86FE/L104**, there is a Brown-Out Detectors (BOD0) to monitor VDD power. BOD0 services the fixed detection level at VDD=2.4V/4.2V. If VDD power drops below BOD0 monitor level. Associated flag, BOF0, is set when BOD0 meets the detection level. If BO0RE (PCON2.1) is enabled, the BOD0 will trigger a system reset and a set BOF0 indicates a BOD0 Reset occurred.

PCON1: Power Control Register 1

SFR Page = Normal & Page P

SFR Address = 0x97

POR = 0010-0x00

7	6	5	4	3	2	1	0
SWRF	EXRF	--	--	KBIF	--	BOF0	WDTF
R/W	R/W	W	W	R/W	W	R/W	R/W

Bit 1: BOF0, BOF0 (Reset) Flag.

0: This bit must be cleared by software writing "1" on it. Software writing ":0" is no operation.

1: This bit is only set by hardware when VDD meets BOD0 monitored level. Writing "1" on this bit will clear BOF0.

If BO0RE (PCON2.1) is enabled, BOF0 indicates a BOD0 Reset occurred.

10.7. WDT Reset

When WDT is enabled to start the counter, WDTF will be set by WDT overflow. If WREN (WDTCR.7) is enabled, the WDT overflow will trigger a system reset that causes CPU to restart. Software can read the WDTF to recognize the WDT reset occurred.

PCON1: Power Control Register 1

SFR Page = Normal & Page P

SFR Address = 0x97

POR = 0010-0x00

7	6	5	4	3	2	1	0
SWRF	EXRF	--	--	KBIF	--	BOF0	WDTF
R/W	R/W	W	W	R/W	W	R/W	R/W

Bit 0: WDTF, WDT Overflow/Reset Flag.

0: This bit must be cleared by software writing "1" on it. Software writing ":0" is no operation.

1: This bit is only set by hardware when WDT overflows. Writing "1" on this bit will clear WDTF. If WREN (WDTCR.7) is set, WDTF indicates a WDT Reset occurred.

10.8. Reset Sample Code

(1) Required function: Trigger a software reset

Assembly Code Example:	
ORL	ISPCR,#SWRST ; Trigger Software Reset
C Code Example:	
ISPCR = SWRST;	// Trigger Software Reset

(2). Required Function: Enable BOD0 reset

Assembly Code Example:	
MOV	IFADRL,#PCON2 ; Index Page-P address to PCON2
CALL	_page_p_sfr_read ; Read PCON2 data
ORL	IFD,#BO0RE ; Enable BOD0 reset function
CALL	_page_p_sfr_write ; Write data to PCON2
C Code Example:	
IFADRL = PCON2;	// Index Page-P address to PCON2
page_p_sfr_read();	// Read PCON2 data
IFD = BO0RE;	// Enable BOD0 reset function
page_p_sfr_write();	// Write data to PCON2

11. Power Management

The **MG86FE/L104** supports one power monitor module, Brown-Out Detector (BOD0), and 6 power-reducing modes: Idle mode, Power-down mode, Slow mode, Sub-Clock mode, Watch mode and Monitor mode.

BOD0 reports the chip power status on the flag, BOF0, which provides the capability to interrupt CPU or to reset CPU by software configured. The six power-reducing modes provide the different power-saving scheme for chip application. These modes are accessed through the CKCON0, CKCON2, PCON0, PCON1, PCON2 and WDTCR register.

11.1. Brown-Out Detector

In **MG86FE/L104**, there is a Brown-Out Detectors (BOD0) to monitor VDD power. **Figure 11–1** shows the functional diagram of BOD0. BOD0 services the fixed detection level at VDD=4.2V for **5V** part and 2.4V on **3.3V** part. Associated flag, BOF0 (PCON1.1), is set when BOD0 meets the detection level. If both of ESF (EIE1.3) and BOF0IE (SFIE.1) are enabled, a set BOF0 will generate a system flag interrupt. It can interrupt CPU either CPU in normal mode or idle mode. The interrupt also wakes up CPU in power down mode if AWBOD0 (PCON2.6) is enabled.

If BO0RE (PCON2.1) is enabled, the BOD0 event will trigger a system reset and set BOF0 to indicate a BOD0 Reset occurred. The BOD0 reset restart the CPU either CPU in normal mode or idle mode. The reset also restart CPU in power down mode if AWBOD0 (PCON2.6) is enabled in BOD0 reset operation.

Figure 11–1. Brown-Out Detector 0

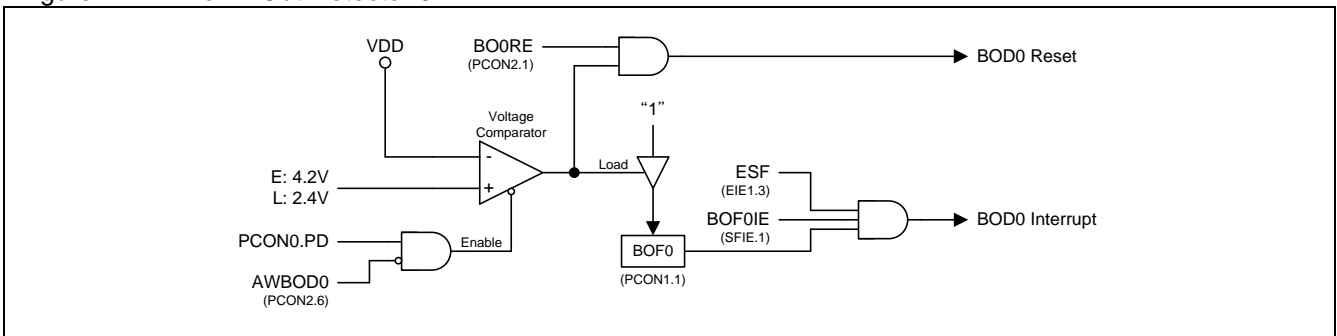

11.2. Power Saving Mode

11.2.1. Slow Mode

The alternative to save the operating power is to slow down the MCU's operating speed by programming SCKS2~SCKS0 bits (in CKCON0 register, see Section "8 System Clock") to a non-0/0/0 value. The user should examine which program segments are suitable for lower operating speed. In principle, the lower operating speed should not affect the system's normal function. Then, restore its normal speed in the other program segments.

11.2.2. Sub-Clock Mode

The alternative to slow down the MCU's operating speed by programming OSCS1~0 can select the ILRCO for system clock. The 64KHz ILRCO provides the MCU to operates in an ultra low speed and low power operation. Additional programming SCKS2~SCKS0 bits (in CKCON0 register, see Section "8 System Clock"), the user could put the MCU speed down to 500Hz slowest.

11.2.3. Watch Mode

If Watch-Dog-Timer is enabled and NSW is set, Watch-Dog-Timer will keep running in power down mode, which named Watch Mode in **MG86FE/L104**. When WDT overflows, set WDTF and wakeup CPU from interrupt or system reset by software configured. The maximum wakeup period is about 2 seconds that is defined by WDT pre-scaler. Please refer Section “9 Watch Dog Timer (WDT)” and Section “13 Interrupt” for more detail information.

11.2.4. Monitor Mode (L-Series Only)

If AWBOD1 (PCON3.3) is set, BOD1 will keep VDD monitor in power down mode. It is the Monitor Mode in **MG86FE/L104**. When BOD1 meets the detection level, set BOF1 and wakeup CPU from interrupt or system reset by software configured. Please refer Section “11.1 Brown-Out Detector” and Section “13 Interrupt” for more detail information. This function is only valid in L-series device.

11.2.5. Idle Mode

Setting the IDL bit in PCON enters idle mode. Idle mode halts the internal CPU clock. The CPU state is preserved in its entirety, including the RAM, stack pointer, program counter, program status word, and accumulator. The Port pins hold the logical states they had at the time that Idle was activated. Idle mode leaves the peripherals running in order to allow them to wake up the CPU when an interrupt is generated. Timer 0, Timer 1, UART, KBI and the BOD0 will continue to function during Idle mode. The WDT is conditional enabled during Idle mode to wake up CPU. Any enabled interrupt source or reset may terminate Idle mode. When exiting Idle mode with an interrupt, the interrupt will immediately be serviced, and following RETI, the next instruction to be executed will be the one following the instruction that put the device into Idle.

11.2.6. Power-Down Mode

Setting the PD bit in PCON enters Power-down mode. Power-down mode stops the oscillator and powers down the Flash memory in order to minimize power consumption. Only the power-on circuitry will continue to draw power during Power-down. During Power-down the power supply voltage may be reduced to the RAM keep-alive voltage. The RAM contents will be retained; however, the SFR contents are not guaranteed once VDD has been reduced. Power-down may be exited by external reset, power-on reset, enabled external interrupts, enabled KBI GPIOs, enabled BOD0 or enabled Non-Stop WDT.

The user should not attempt to enter (or re-enter) the power-down mode for a minimum of 4 μ s until after one of the following conditions has occurred: Start of code execution (after any type of reset), or Exit from power-down mode. To ensure minimum power consumption in power down mode, software must confirm all I/O not in floating state, including the port I/Os un-appearance on package pins. For example, P1.7~P1.0 and P4.1~P4.0 are un-appearance in MG86FE/L104AS8 (SOP8) package pins. Software may configure P1/P4 corresponding bit SFR to “0” (output low) to avoid pin floating in power-down mode.

Figure 11–2 shows the wakeup mechanism of power-down mode in **MG86FE/L104**.

Figure 11–2. Wakeup structure of Power Down mode

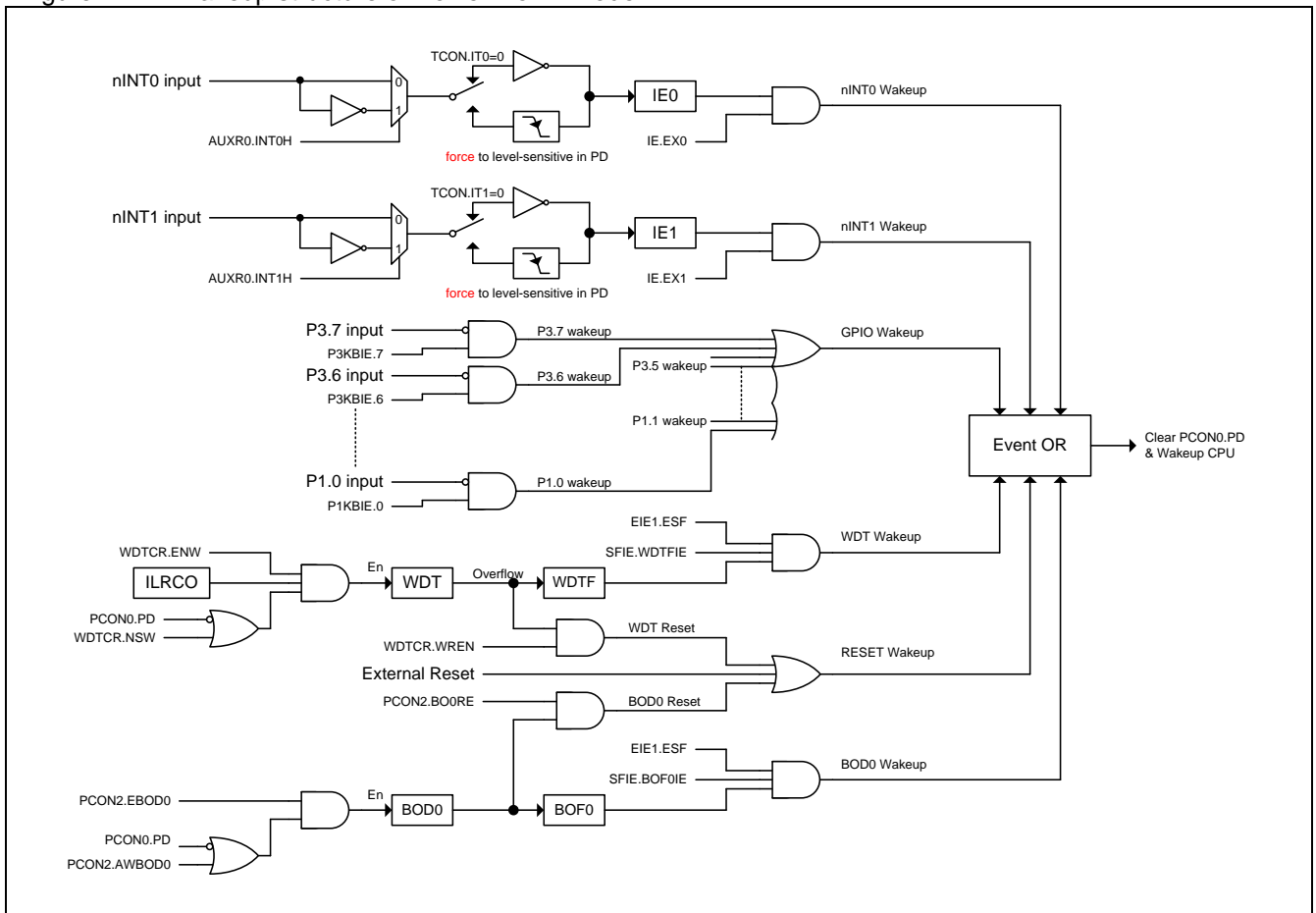

11.2.7. Interrupt Recovery from Power-down

Two external interrupts may be configured to terminate Power-down mode. External interrupts nINT0 (P3.2), nINT1 (P3.3) may be used to exit Power-down. To wake up by external interrupt nINT0, nINT1, the interrupt must be enabled and configured for level-sensitive operation. If the enabled external interrupts are configured to edge-sensitive operation (Falling or Rising), they will be forced to level-sensitive operation (Low level or High level) by hardware in power-down mode.

When terminating Power-down by an interrupt, the wake up period is internally timed. At the falling edge on the interrupt pin, Power-down is exited, the oscillator is restarted, and an internal timer begins counting. The internal clock will not be allowed to propagate and the CPU will not resume execution until after the timer has reached internal counter full. After the timeout period, the interrupt service routine will begin. To prevent the interrupt from re-triggering, the ISR should disable the interrupt before returning. The interrupt pin should be held low until the device has timed out and begun executing.

11.2.8. Reset Recovery from Power-down

If P3.6 is configured for RST input pin, wakeup from Power-down through an external reset is similar to the interrupt. At the rising edge of RST, Power-down is exited, the oscillator is restarted, and an internal timer begins counting. The internal clock will not be allowed to propagate to the CPU until after the timer has reached internal counter full. The RST pin must be held high for longer than the timeout period to ensure that the device is reset properly. The device will begin executing once RST is brought low.

It should be noted that when idle is terminated by a hardware reset, the device normally resumes program execution, from where it left off, up to two machine cycles before the internal reset algorithm takes control. On-chip hardware inhibits access to internal RAM in this event, but access to the port pins is not inhibited. To

eliminate the possibility of an unexpected write to a port pin when Idle is terminated by reset, the instruction following the one that invokes Idle should not be one that writes to a port pin or to external memory.

11.2.9. KBI Recovery from Power-down

The GPIOs of **MG86FE/L104**, P1.7 ~ P1.0, P3.7~P3.4, P41, P40, P31 and P30 have wakeup CPU capability that are enabled by individual control bit in P1KBIE and P3KBIE. P3.2/nINT0 and P3.3/nINT1 have the wakeup capability from the interrupt function.

Wakeup from Power-down through an enabled KBI GPIO is similar to the interrupt. At the low-level of enabled KBI GPIO, Power-down is exited, the oscillator is restarted, and an internal timer begins counting. The internal clock will not be allowed to propagate to the CPU until after the timer has reached internal counter full. After the timeout period, CPU will meet a KBI interrupt and execute the interrupt service routine. Please refer Section [“16 Keypad Interrupt \(KBI\)”](#) for more detail information.

11.3. Power Control Register

PCON0: Power Control Register 0

SFR Page = Normal & Page P

SFR Address = 0x87

POR = 0001-0000, RESET = 000x-0000

7	6	5	4	3	2	1	0
SMOD1	SMOD0	--	POF	GF1	GF0	PD	IDL
R/W	R/W	R/W	R/W	R/W	R/W	R/W	R/W

Bit 4: POF, Power-On Flag.

0: This bit must be cleared by software writing one to it.

1: This bit is set by hardware if a Power-On Reset occurs.

Bit 1: PD, Power-Down control bit.

0: This bit could be cleared by CPU or any exited power-down event.

1: Setting this bit activates power down operation.

Bit 0: IDL, Idle mode control bit.

0: This bit could be cleared by CPU or any exited Idle mode event.

1: Setting this bit activates idle mode operation.

PCON1: Power Control Register 1

SFR Page = Normal & Page P

SFR Address = 0x97

POR = 0010-0x00

7	6	5	4	3	2	1	0
SWRF	EXRF	--	--	KBIF	--	BOF0	WDTF
R/W	R/W	W	W	R/W	W	R/W	R/W

Bit 7: SWRF, Software Reset Flag.

0: This bit must be cleared by software writing "1" to it.

1: This bit is set by hardware if a Software Reset occurs.

Bit 6: EXRF, External Reset Flag.

0: This bit must be cleared by software writing "1" to it.

1: This bit is set by hardware if an External Reset occurs.

Bit 5~4: Reserved. Software must write "0" on these bits when PCON1 is written.

Bit 3: KBIF, KBI Flag.

0: This bit must be cleared by software writing "1" to it.

1: This bit is set by hardware if a KBI input event occurs.

Bit 2: Reserved. Software must write "0" on this bit when PCON1 is written.

Bit 1: BOF0, Brown-Out Detection flag 0.

0: This bit must be cleared by software writing "1" to it.

1: This bit is set by hardware if the operating voltage matches the detection level of Brown-Out Detector 0 (E: 4.2V, L: 2.4V).

Bit 0: WDTF, WDT overflow flag.

0: This bit must be cleared by software writing "1" to it.

1: This bit is set by hardware if a WDT overflow occurs.

PCON2: Power Control Register 2

SFR Page = P Only

SFR Address = 0x44

POR = x0xx-xx01

7	6	5	4	3	2	1	0
--	AWBOD0	--	--	--	--	BO0RE	1
W	W	W	W	W	W	W	W

Bit 7: Reserved. Software must write "0" on this bit when PCON2 is written.

Bit 2: AWBOD0, Awaked BOD0 in PD mode.

0: BOD0 is disabled in power-down mode.

1: BOD0 keeps operation in power-down mode.

Bit 5~2: Reserved. Software must write "0" on these bits when PCON2 is written.

Bit 1: BO0RE, BOD0 Reset Enabled. Its initial is loaded from OR1.BO0RE0 inverted.

0: Disable BOD0 to trigger a system reset when BOF0 is set.

1: Enable BOD0 to trigger a system reset when BOF0 is set by VDD meets 4.2V(E) or 2.4V(L).

Bit 7: Reserved for test. Software must write "1" on this bit when PCON2 is written.

P1KBIE: Port 1 KBI Enable Control Register

SFR Page = Normal

SFR Address = 0xD7

RESET = 0000-0000

7	6	5	4	3	2	1	0
P17KBIE	P16KBIE	P15KBIE	P14KBIE	P13KBIE	P12KBIE	P11KBIE	P10KBIE
R/W	R/W	R/W	R/W	R/W	R/W	R/W	R/W

Bit 7~0: Keypad Input function enable bit for each Port 1 pins.

0: Disable associated port pin for keypad input function.

1: Enable associated port pin for keypad input function on low level.

P3KBIE: Port 3 KBI Enable Control Register

SFR Page = Normal

SFR Address = 0xD6

RESET = 0000-0000

7	6	5	4	3	2	1	0
P37KBIE	P36KBIE	P35KBIE	P34KBIE	P41KBIE	P40KBIE	P31KBIE	P30KBIE
R/W	R/W	R/W	R/W	R/W	R/W	R/W	R/W

Bit 7~0: Keypad Input function enable bit for P3.7 ~ P3.4, P4.1, P4.0, P3.1 and P3.0 pins.

0: Disable associated port pin for keypad input function.

1: Enable associated port pin for keypad input function on low level.

11.4. Power Control Sample Code

(1) Required function: Select Slow mode with OSCin/128 (default is OSCin/2)

Assembly Code Example:	
ORL	CKCON0,#(SCK0 SCK1 SCK2) ; OSCin/128
MOV	IFADRL,#DCON0 ; Index Page-P address to DCON0
CALL	_page_p_sfr_read ; Read DCON0 data
ANL	IFD,#~(HSE) ; Disable HSE when SYSCLK ≤ 6MHz for power saving
CALL	_page_p_sfr_write ; Write data to DCON0
C Code Example:	
CKCON0 = (SCK2 SCK1 SCK0);	// Select system clock divider to OSCin/128.
IFADRL = DCON0;	// Index Page-P address to DCON0
page_p_sfr_read();	// Read DCON0 data.
IFD &= ~HSE;	// Disable HSE when SYSCLK ≤ 6MHz for power saving
page_p_sfr_write();	// Write data to DCON0

(2) Required function: Select Sub-Clock mode with OSCin/2 (default is OSCin/2=32KHz/2=16KHz)

Assembly Code Example:	
MOV	IFADRL,#CKCON2 ; Index Page-P address to CKCON2
CALL	_page_p_sfr_read ; Read CKCON2 data
ANL	IFD,#~(OSCS1 OSCS0) ; Switch OSCin source to ILRCO
ORL	IFD,#OSCS1
CALL	_page_p_sfr_write ; Write data to CKCON2
ANL	IFD,#~(IHRCOE XTALE) ; Disable IHRCO & XTAL
CALL	_page_p_sfr_write ; Write data to CKCON2
MOV	IFADRL,#DCON0 ; Index Page-P address to DCON0
CALL	_page_p_sfr_read ; Read DCON0 data
ANL	IFD,#~(HSE) ; Disable HSE when SYSCLK ≤ 6MHz for power saving
CALL	_page_p_sfr_write ; Write data to DCON0
MOV	A,CKCON0 ; Select system clock = OSCin/2
ANL	A,#~(SCK2 SCK1 SCK0)
ORL	A,#SCK0
MOV	CKCON0,A
C Code Example:	
IFADRL = CKCON2;	// Index Page-P address to CKCON2
page_p_sfr_read();	// Read CKCON2 data
IFD &= ~(OSCS1 OSCS0);	// Switch OSCin source to ILRCO
IFD = OSCS1;	
page_p_sfr_write();	// Write data to CKCON2
IFD = IFD & ~(IHRCOE XTALE);	// Disable IHRCO & XTAL
page_p_sfr_write();	// Write data to CKCON2
IFADRL = DCON0;	// Index Page-P address to DCON0
page_p_sfr_read();	// Read DCON0 data
IFD = IFD & ~(HSE);	// Disable HSE when SYSCLK ≤ 6MHz for power saving

```

page_p_sfr_write();           // Write data to DCON0

ACC = CKCON0;                // Select system clock = OSCin/2
ACC &= ~(SCK2 | SCK1 | SCK0);
ACC |= SCK0;
CKCON0 = ACC;

```

(3). Required Function: Switch MCU running with XTAL mode

Assembly Code Example:

```

MOV    IFADRL,#CKCON2        ; Index Page-P address to CKCON2
CALL   _page_p_sfr_read      ; Read CKCON2 data

ORL    IFD,#(XTALE)          ; Enable XTAL oscillating
CALL   _page_p_sfr_write     ; Write data to CKCON2

check_XTOR_0:                ; Check XTAL oscillating ready
MOV    A,AUXR1
JNB    ACC.4,check_XTOR_0    ; Waiting for XTOR(AUXR1.4) true

ANL    IFD,#~(OSCS1|OSCS0)   ; Switch OSCin source to XTAL
ORL    IFD,#OSCS0
CALL   _page_p_sfr_write     ; Write data to CKCON2

ANL    IFD,#~(IHRCOE)        ; Disable IHRCO
CALL   _page_p_sfr_write     ; Write data to CKCON2

MOV    IFADRL,#DCON0        ; Index Page-P address to DCON0
CALL   _page_p_sfr_read      ; Read DCON0 data

ANL    IFD,#~(HSE)           ; Disable HSE when SYSCLK ≤ 6MHz for power saving
CALL   _page_p_sfr_write     ; Write data to DCON0

ANL    CKCON0,#~(SCK2|SCK1|SCK0) ; SYSCLK = OSCin/1

```

C Code Example:

```

IFADRL = CKCON2;           // Index Page-P address to CKCON2
page_p_sfr_read();        // Read CKCON2 data

IFD |= XTALE;              // Enable XTAL oscillating
page_p_sfr_write();       // Write data to CKCON2

while( AUXR1&XTOR == 0x00 ); // Check XTAL oscillating ready
                               // Waiting for XTOR(AUXR1.4) true

IFD &= ~(OSCS1 | OSCS0);   // Switch OSCin source to XTAL.
IFD |= OSCS0;
page_p_sfr_write ();      // Write data to CKCON2

IFD &= ~IHRCOE;           // Disable IHRCO if MCU is switched from IHRCO
page_p_sfr_write();       // Write data to CKCON2.

IFADRL = DCON0;           // Index Page-P address to DCON0
page_p_sfr_read();        // Read DCON0 data.

IFD &= ~HSE;              // Disable HSE when SYSCLK ≤ 6MHz for power saving
page_p_sfr_write();       // Write data to DCON0

CKCON0 &= ~(SCK2 | SCK1 | SCK0); // SYSCLK = OSCin/1

```

(4). Required Function: Enter Watch mode with 2S wake-up duration

Assembly Code Example:

```

ORG    0003Bh
SystemFlag_ISR:

```

```

ANL   PCON1,#(WDTF)           ; Clear WDT flag (write "1")
RETI

main:
ANL   PCON1,#WDTF             ; Clear WDTF flag (write "1")
ORL   WDTCR,#(NSW|ENW|PS2|PS1|PS0)
                                   ; Enable WDT and NSW (for watch mode)
                                   ; Set PS[2:0] = 7 to select WDT period for 1.984s

ORL   SFIE,#WDTFIE           ; Enable WDT interrupt
ORL   EIE1,#ESF              ; Enable SystemFlag interrupt
SETB  EA                     ; Enable Global interrupt

ORL   PCON0,#PD              ; Set MCU to power down

;   MCU wait for wake-up

```

C Code Example:

```

void SystemFlag_ISR (void) interrupt 7
{
    PCON1 &= WDTF;                // Clear WDT flag (write "1")
}

void main (void)
{
    PCON1 &= WDTF;                // Clear WDT flag (write "1")
    WDTCR |= (NSW | ENW | PS2 | PS1 | PS0); // Enable WDT and NSW (for watch mode)
                                           // Set PS[2:0] = 7 to select WDT period for 1.984s

    SFIE |= WDTFIE;              // Enable WDT interrupt
    EIE1 |= ESF;                 // Enable SystemFlag interrupt
    EA = 1;                      // Enable global interrupt

    PCON0 |= PD;                 // Set MCU to power down

//   MCU wait for wake-up
}

```

(5. Required Function: Monitor Mode (L-series only))

Assembly Code Example:

```

ORG   0003Bh
SystemFlag_ISR:
ANL   PCON1,#(BOF0)           ; Clear BOD0 flag (write "1")
RETI

main:
MOV   IFADRL,#PCON2           ; Index Page-P address to PCON2
CALL  _page_p_sfr_read        ; Read PCON2 data

ORL   IFD,#AWBOD0             ; Enable BOD0 operating in power-down mode
CALL  _page_p_sfr_write      ; Write data to PCON2

ORL   SFIE,#BOF0IE           ; Enable BOF0 interrupt
ORL   EIE1,#ESF              ; Enable SystemFlag interrupt
SETB  EA                     ; Enable global interrupt

ORL   PCON0,#PD              ; Set MCU to power down

;   MCU wait for wake-up

```

C Code Example:

```

void SystemFlag_ISR() interrupt 7
{

```



```

    PCON1 &= BOF0;                // Clear BOD0 flag (write "1")
}

void main()
{
    IFADRL = PCON2;                // Index Page-P address to PCON2
    page_p_sfr_read();            // Read PCON2 data

    IFD |= AWBOD0;                // Enable BOD0 operating in power-down mode
    page_p_sfr_write();           // Write data to PCON2

    SFIE |= BOF0IE;               // Enable BOD0 interrupt
    EIE1 |= ESF;                  // Enable SystemFlag interrupt
    EA = 1;                        // Enable global interrupt

    PCON0 |= PD;                  // Set MCU to power down

// MCU wait for wake-up
}

```

(6). Required Function: Safety and Fast wakeup for XTAL mode in power-down

Assembly Code Example:

```

MOV    IFADRL,#CKCON2            ; Index Page-P address to CKCON2
CALL   _page_p_sfr_read          ; Read CKCON2 data

ORL    IFD,#IHRCOE               ; Enable IHRCO
CALL   _page_p_sfr_write         ; Write data to CKCON2

Delay_32us

ANL    IFD,#~(OSCS1|OSCS0)       ; Switch OSCin source to IHRCO
CALL   _page_p_sfr_write         ; Write data to CKCON2

ORL    PCON0,#PD                 ; Set MCU to power down

; MCU wait for wake-up

check_XTOR:                       ; Check XTAL oscillating ready
MOV    A,AUXR1
JNB    ACC.4,check_XTOR          ; Waiting for XTOR(AUXR1.4) true

ANL    IFD,#~(OSCS1 | OSCS0)     ; Switch OSCin source to XTAL.
ORL    IFD,#(OSCS0)
CALL   _page_p_sfr_write         ; Write data to CKCON2

ANL    IFD,#~(IHRCOE)            ; Disable IHRCO if MCU is switched from IHRCO
CALL   _page_p_sfr_write         ; Write data to CKCON2

```

C Code Example:

```

IFADRL = CKCON2;                // Index Page-P address to CKCON2
page_p_sfr_read();              // Read CKCON2 data

IFD |= IHRCOE;                  // Enable IHRCO
page_p_sfr_write();             // Write data to CKCON2

Delay_32us();

IFD &= ~(OSCS1 | OSCS0);        // Switch OSCin source to IHRCO
page_p_sfr_write();            // Write data to CKCON2

PCON0 |= PD;                    // Set MCU to power down

// MCU wait for wake-up

```

```
while(AUXR1 & XTOR == 0x00);           // Check XTAL oscillating ready
                                        // Waiting for XTOR(AUXR1.4) true

IFD &= ~(OSCS1 | OSCS0);               // Switch OSCin source to XTAL.
IFD |= OSCS0;
page_p_sfr_write ();                  // Write data to CKCON2

IFD &= ~IHRCOE;                        // Disable IHRCO if MCU is switched from IHRCO
page_p_sfr_write();                   // Write data to CKCON2.
```

12. Configurable I/O Ports

The **MG86FE/L104** has following I/O ports: P1.0~P1.7, P3.0~P3.5 and P3.7. RST pin has a swapped function for P3.6. If select external crystal oscillator as system clock input, Port 4.0 and Port 4.1 are configured to XTAL2 and XTAL1. The exact number of I/O pins available depends upon the package types. See [Table 12–1](#).

Table 12–1. Number of I/O Pins Available

Package Type	I/O Pins	Number of I/O ports
20-pin SOP	P1.0~P1.7, P3.0~P3.5, P3.7, RST(P3.6), XTAL2(P4.0), XTAL1(P4.1)	15 or 16 (RST/P3.6) or 18 (INTOSC enabled)
16-pin SOP	P1.0~P1.6, P3.0~P3.3, RST(P3.6), XTAL2(P4.0), XTAL1(P4.1)	11 or 12 (RST/P3.6) or 14 (INTOSC enabled)
8-pin SOP	P3.0~P3.5	6

12.1. IO Structure

The I/O operating modes are distinguished two groups in **MG86FE/L104**. The first group is only for Port 3 to support four configurations on I/O operating. These are: quasi-bidirectional (standard 8051 I/O port), push-pull output, input-only (high-impedance input) and open-drain output.

All other general port pins are belonged to secondary group. They can be configured to two output modes, push-pull output and open-drain output with pull-up resistor control.

Followings describe the configuration of the all types I/O mode.

12.1.1. Port 3 Quasi-Bidirectional IO Structure

Port 3 pins in quasi-bidirectional mode are similar to the standard 8051 port pins. A quasi-bidirectional port can be used as an input and output without the need to reconfigure the port. This is possible because when the port outputs a logic high, it is weakly driven, allowing an external device to pull the pin low. When the pin outputs low, it is driven strongly and able to sink a large current. There are three pull-up transistors in the quasi-bidirectional output that serve different purposes.

One of these pull-ups, called the “very weak” pull-up, is turned on whenever the port register for the pin contains a logic “1”. This very weak pull-up sources a very small current that will pull the pin high if it is left floating. A second pull-up, called the “weak” pull-up, is turned on when the port register for the pin contains a logic “1” and the pin itself is also at a logic “1” level. This pull-up provides the primary source current for a quasi-bidirectional pin that is outputting a 1. If this pin is pulled low by the external device, this weak pull-up turns off, and only the very weak pull-up remains on. In order to pull the pin low under these conditions, the external device has to sink enough current to over-power the weak pull-up and pull the port pin below its input threshold voltage. The third pull-up is referred to as the “strong” pull-up. This pull-up is used to speed up low-to-high transitions on a quasi-bidirectional port pin when the port register changes from a logic “0” to a logic “1”. When this occurs, the strong pull-up turns on for one CPU clocks, quickly pulling the port pin high.

The quasi-bidirectional port configuration on Port 3 is shown in [Figure 12–1](#).

Figure 12–1. Port 3 Quasi-Bidirectional I/O

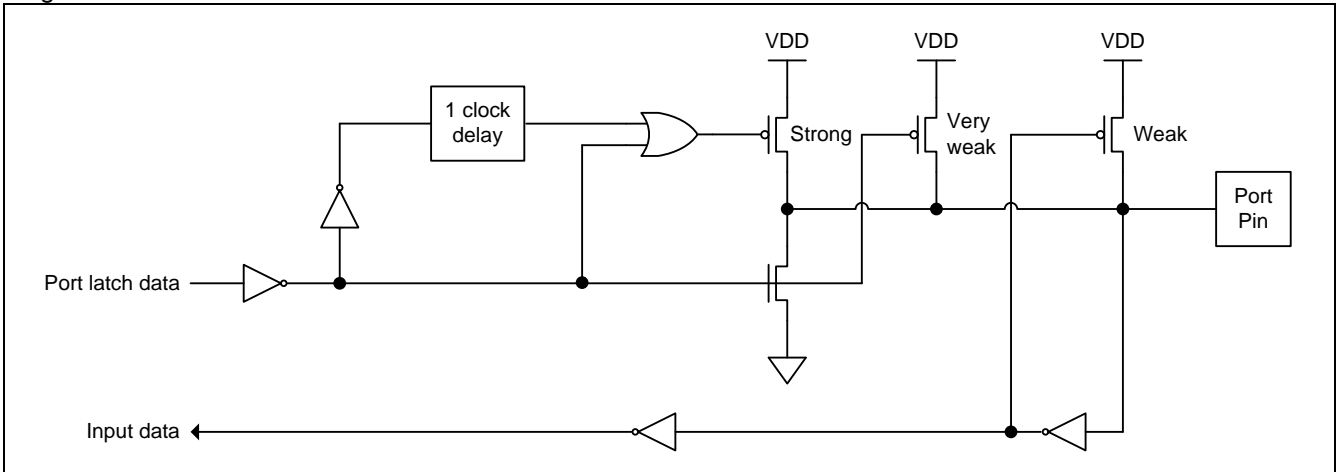

12.1.2. Port 3 Push-Pull Output Structure

The push-pull output configuration on Port 3 has the same pull-down structure as both the open-drain and the quasi-bidirectional output modes, but provides a continuous strong pull-up when the port register contains a logic “1”. The push-pull mode may be used when more source current is needed from a port output. In addition, the input path of the port pin in this configuration is also the same as quasi-bidirectional mode.

The push-pull port configuration on Port 3 is shown in [Figure 12–2](#).

Figure 12–2. Port 3 Push-Pull Output

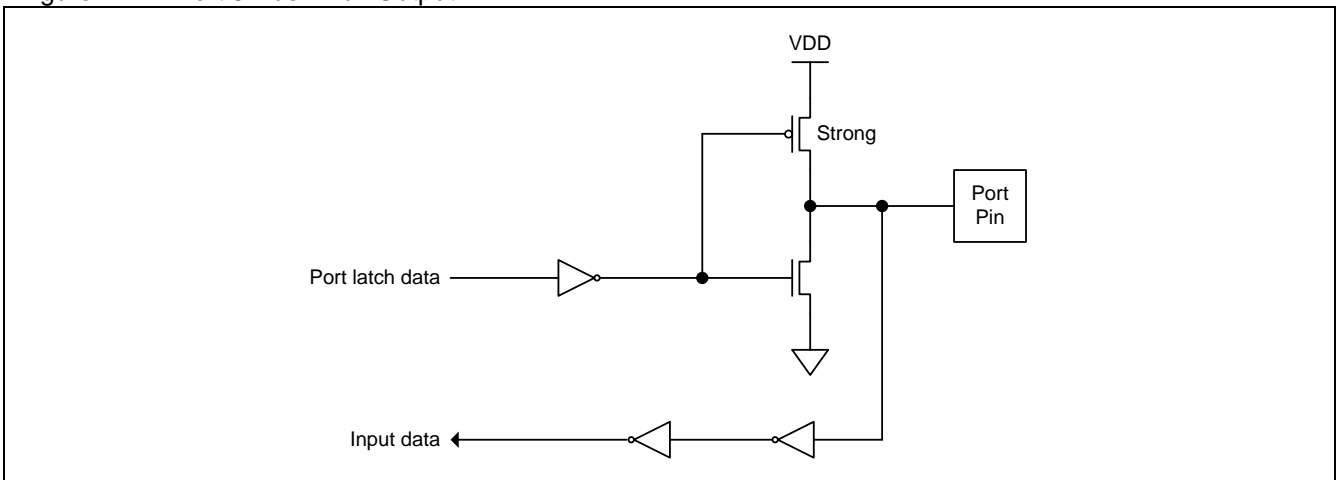

12.1.3. Port 3 Input-Only (High Impedance Input) Structure

The input-only configuration on Port 3 is an input without any pull-up resistors on the pin, as shown in [Figure 12–3](#).

Figure 12–3. Port 3 Input-Only

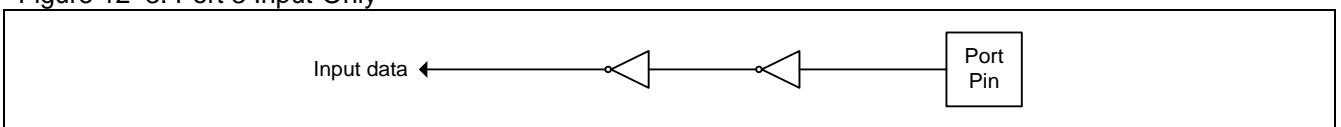

12.1.4. Port 3 Open-Drain Output Structure

The open-drain output configuration on Port 3 turns off all pull-ups and only drives the pull-down transistor of the port pin when the port register contains a logic “0”. To use this configuration in application, a port pin must have an external pull-up, typically a resistor tied to VDD. The pull-down for this mode is the same as for the quasi-bidirectional mode. In addition, the input path of the port pin in this configuration is also the same as quasi-bidirectional mode.

The Port 3 open-drain port configuration is shown in [Figure 12–4](#).

Figure 12–4. Port 3 Open-Drain Output

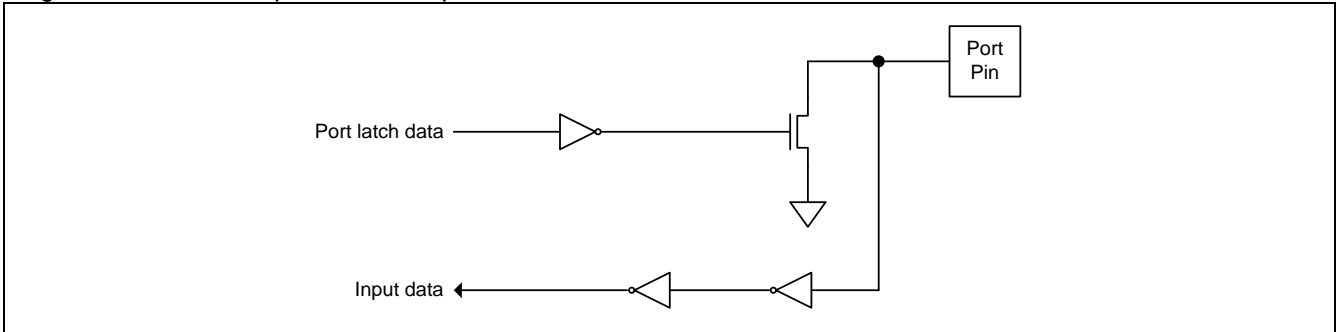

12.1.5. General Open-Drain Output Structure

The open-drain output configuration on general port pins only drives the pull-down transistor of the port pin when the Port Data register contains a logic “0”. To use this configuration in application, a port pin can select an external pull-up, or an on-chip pull-up by software enabled in PUCON0.

The general open-drain port configuration is shown in [Figure 12–5](#).

Figure 12–5. General Open-Drain Output

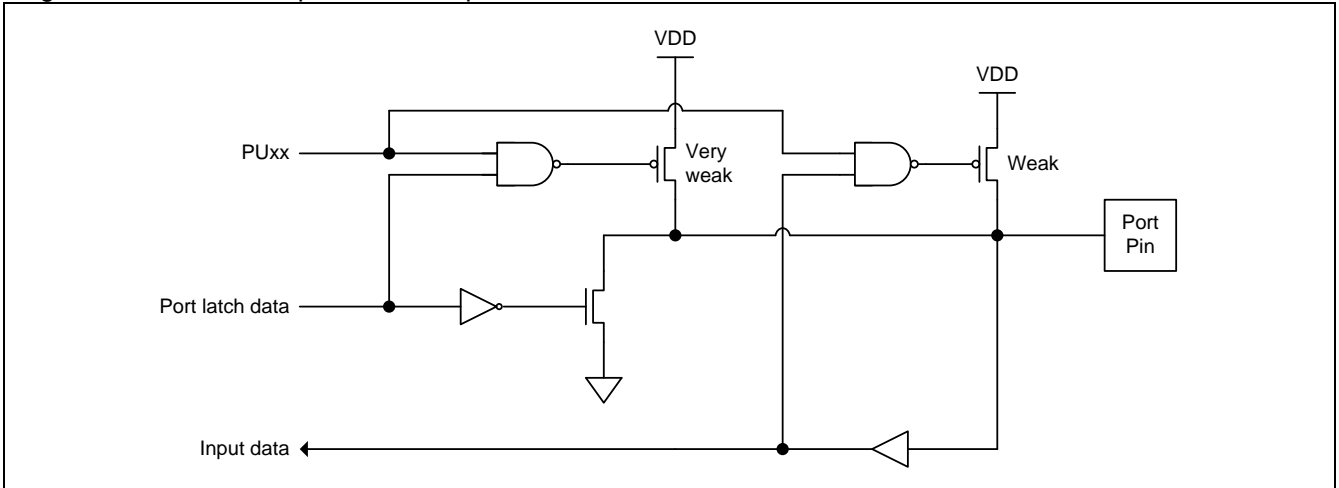

12.1.6. General Push-Pull Output Structure

The push-pull output configuration on general port pins has the same pull-down structure as the open-drain output modes, but provides a continuous strong pull-up when the port register contains a logic “1”. The push-pull mode may be used when more source current is needed from a port output. In addition, the input path of the port pin in this configuration is also the same as open-drain mode.

The push-pull port configuration is shown in [Figure 12–6](#).

Figure 12–6. General Push-Pull Output

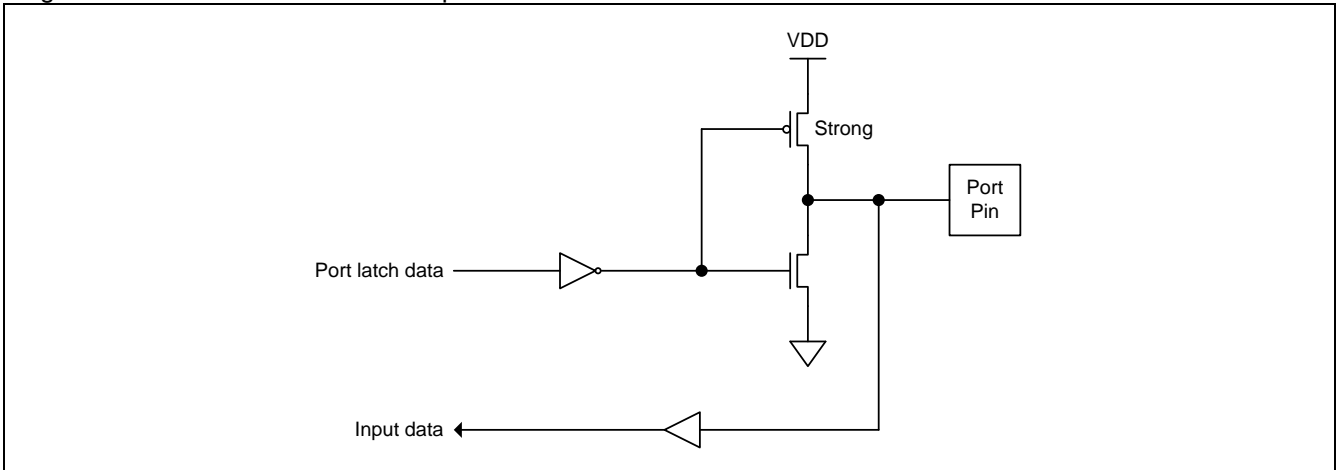

12.1.7. General Port Input Configured

A Port pin is configured as a digital input by setting its output mode to “Open-Drain” and writing a logic “1” to the associated bit in the Port Data register. For example, P1.7 is configured as a digital input by setting P1M0.7 to a logic 0 and P1.7 to a logic 1.

12.2. I/O Port Register

All I/O port pins on the **MG86FE/L104** may be individually and independently configured by software to select its operating mode. Only Port 3 has four operating modes, as shown in [Table 12–2](#). Two mode registers select the output type for each port 3 pin.

Table 12–2. Port 3 Configuration Settings

P3M0.y	P3M1.y	Port Mode
0	0	Quasi-Bidirectional
0	1	Push-Pull Output
1	0	Input Only (High Impedance Input)
1	1	Open-Drain Output

Where y=0~7 (port pin). The registers P3M0 and P3M1 are listed in each port description.

Other general port pins support two operating modes, as shown in [Table 12–3](#). One mode register selects the output type for each port pin.

Table 12–3. General Port Configuration Settings

PxM0.y	Port Mode
0	Open-Drain Output
1	Push-Pull Output

Where x=1, 4 (port number), and y=0~7 (port pin). The registers PxM0 and PxM1 are listed in each port description.

12.2.1. Port 1 Register

P1: Port 1 Register

SFR Page = Normal

SFR Address = 0x90

RESET = 1111-1111

7	6	5	4	3	2	1	0
P1.7	P1.6	P1.5	P1.4	P1.3	P1.2	P1.1	P1.0
R/W	R/W	R/W	R/W	R/W	R/W	R/W	R/W

Bit 7~0: P1.7~P1.0 could be only set/cleared by CPU.

P1M0: Port 1 Mode Register 0

SFR Page = Normal

SFR Address = 0x91

RESET = 0000-0000

7	6	5	4	3	2	1	0
P1M0.7	P1M0.6	P1M0.5	P1M0.4	P1M0.3	P1M0.2	P1M0.1	P1M0.0
R/W	R/W	R/W	R/W	R/W	R/W	R/W	R/W

0: Port pin output mode is configured to open-drain.

1: Port pin output mode is configured to push-pull.

12.2.2. Port 3 Register

P3: Port 3 Register

SFR Page = Normal

SFR Address = 0xB0

RESET = 1111-1111

7	6	5	4	3	2	1	0
P3.7	P3.6	P3.5	P3.4	P3.3	P3.2	P3.1	P3.0
R/W	R/W	R/W	R/W	R/W	R/W	R/W	R/W

Bit 7~0: P3.7~P3.0 could be only set/cleared by CPU.

P3M0: Port 3 Mode Register 0

SFR Page = Normal

SFR Address = 0xB1

RESET = 0000-0000

7	6	5	4	3	2	1	0
P3M0.7	P3M0.6	P3M0.5	P3M0.4	P3M0.3	P3M0.2	P3M0.1	P3M0.0
R/W	R/W	R/W	R/W	R/W	R/W	R/W	R/W

P3M1: Port 3 Mode Register 1

SFR Page = Normal

SFR Address = 0xB2

RESET = 0000-0000

7	6	5	4	3	2	1	0
P3M1.7	P3M1.6	P3M1.5	P3M1.4	P3M1.3	P3M1.2	P3M1.1	P3M1.0
R/W	R/W	R/W	R/W	R/W	R/W	R/W	R/W

12.2.3. Port 4 Register

P4: Port 4 Register

SFR Page = Normal

SFR Address = 0xE8

RESET = xxxx-xx11

7	6	5	4	3	2	1	0
--	--	--	--	--	--	P4.1	P4.0
W	W	W	W	W	W	R/W	R/W

Bit 7~2: Reserved.

Bit 1~0: P4.1~P4.0 could be only set/cleared by CPU. P4.1 and P4.0 have the alternated function for crystal oscillating circuit, XTAL1 and XTAL2.

P4M0: Port 4 Mode Register 0

SFR Page = Normal

SFR Address = 0xB3

RESET = xxxx-xx00

7	6	5	4	3	2	1	0
--	--	--	--	--	--	P4M0.1	P4M0.0
W	W	W	W	W	W	R/W	R/W

0: Port pin output mode is configured to open-drain.

1: Port pin output mode is configured to push-pull.

12.2.4. Pull-Up Control Register

PUCON0: Port Pull-up Control Register 0

SFR Page = Normal

SFR Address = 0xB4

RESET = x0xx-00xx

7	6	5	4	3	2	1	0
--	PU40	--	--	PU11	PU10	--	--
W	R/W	W	W	R/W	R/W	W	W

Bit 7: Reserved. Software must write "0" on this bit when PUCON0 is written.

Bit 6: Port 4 pull-up enable control on low nibble.

0: Disable the P4.0 & P4.1 pull-up resistor in open-drain output mode.

1: Enable the P4.0 & P4.1 pull-up resistor in open-drain output mode.

Bit 5~4: Reserved. Software must write "0" on these bits when PUCON0 is written.

Bit 3: Port 1 pull-up enable control on high nibble.

0: Disable the P1.7 ~ P1.4 pull-up resistor in open-drain output mode.

1: Enable the P1.7 ~ P1.4 pull-up resistor in open-drain output mode.

Bit 2: Port 1 pull-up enable control on low nibble.

0: Disable the P1.3 ~ P1.0 pull-up resistor in open-drain output mode.

1: Enable the P1.3 ~ P1.0 pull-up resistor in open-drain output mode.

Bit 1~0: Reserved. Software must write "0" on these bits when PUCON0 is written.

12.3. GPIO Sample Code

(1). Required Function: Set P1.0 to input mode with on-chip pull-up resistor enabled

Assembly Code Example:		
ANL	P1M0,#~P1M00	; Configure P1.0 to open drain mode
SETB	P10	; Set P1.0 data latch to "1" to enable input mode
ORL	PUCON0,#PU10	; Enable the P1.3~P1.0 on-chip pull-up resistor
C Code Example:		
P1M0 &= P1M00;		// Configure P1.0 to open drain mode
P10 = 1;		// Set P1.0 data latch to "1" to enable input mode
PUCON0 = PU10;		// Enable the P1.3~P1.0 on-chip pull-up resistor

(2). Required Function: Switch RST pint to P3.6

Assembly Code Example:		
MOV	IFADRL,#DCON0	; Index Page-P address to DCON0
CALL	_page_p_sfr_read	; Read DCON0 data
ANL	IFD,#~(RSTIO)	; Select I/O pad function for P36
CALL	_page_p_sfr_write	; Write data to DCON0
C Code Example:		
IFADRL = DCON0;		// Index Page-P address to DCON0
page_p_sfr_read();		// Read DCON0 data.
IFD &= ~RSTIO;		// Select I/O pad function for P36
page_p_sfr_write();		// Write data to DCON0

13. Interrupt

The **MG86FE/L104** has 6 interrupt sources with a four-level interrupt structure. There are several SFRs associated with the four-level interrupt. They are the IE, IP0L, IP0H, EIE1, EIP1L and EIP1H. The IP0H (Interrupt Priority 0 High) and EIP1H (Extended Interrupt Priority 1 High) registers make the four-level interrupt structure possible. The four priority level interrupt structure allows great flexibility in handling these interrupt sources.

13.1. Interrupt Structure

Table 13–1 lists all the interrupt sources. The ‘Request Bits’ are the interrupt flags that will generate an interrupt if it is enabled by setting the ‘Enable Bit’. Of course, the global enable bit EA (in IE0 register) should have been set previously. The ‘Request Bits’ can be set or cleared by software, with the same result as though it had been set or cleared by hardware. That is, interrupts can be generated or pending interrupts can be cancelled in software. The ‘Priority Bits’ determine the priority level for each interrupt. The ‘Priority within Level’ is the polling sequence used to resolve simultaneous requests of the same priority level. The ‘Vector Address’ is the entry point of an interrupt service routine in the program memory.

Figure 13–1 shows the interrupt system. Each of these interrupts will be briefly described in the following sections.

Table 13–1. Interrupt Sources

No	Source Name	Enable Bit	Request Bits	Priority Bits	Polling Priority	Vector Address
#1	External Interrupt 0, nINT0	EX0	IE0	[PX0H, PX0L]	(Highest)	0003H
#2	Timer 0	ET0	TF0	[PT0H, PT0L]	...	000Bh
#3	External Interrupt 1, nINT1	EX1	IE1	[PX1H, PX1L]	...	0013H
#4	Timer 1	ET1	TF1	[PT1H, PT1L]	...	001BH
#5	Serial Port 0	ES	RI, TI	[PSH, PSL]	...	0023H
#6	System Flag	ESF	BOF0,WDTF KBIF,(TI)	[PSFH, PSFL]	(Lowest)	002BH

Figure 13–1. Interrupt System

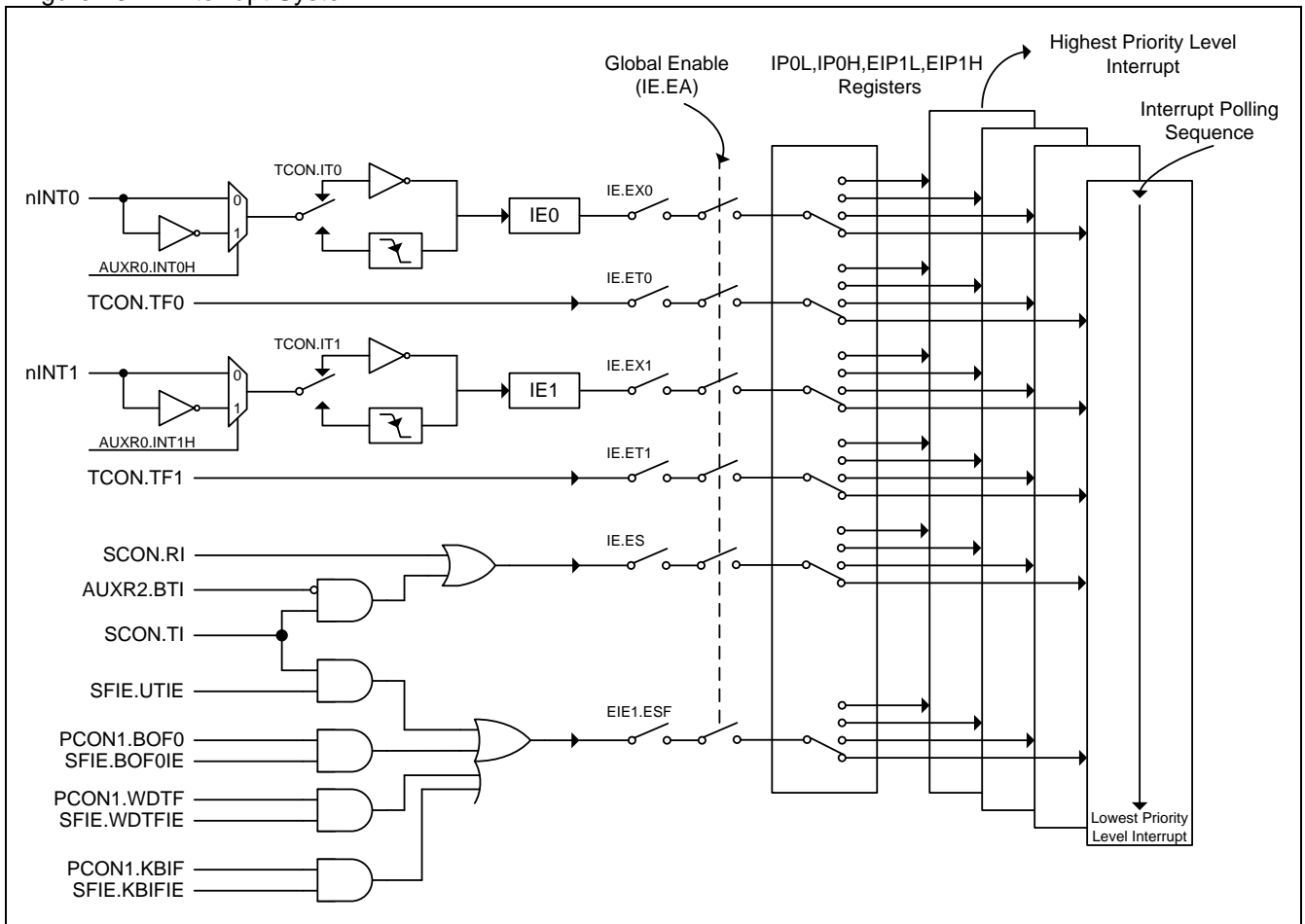

13.2. Interrupt Source

Table 13–2. Interrupt Source Flag

No	Source Name	Request Bits	Bit Location
#1	External Interrupt, nINT0	IE0	TCON.1
#2	Timer 0	TF0	TCON.5
#3	External Interrupt, nINT1	IE1	TCON.3
#4	Timer 1	TF1	TCON.7
#5	Serial Port 0	RI0 TI0	SCON0.0 SCON0.1
#6	System Flag	WDTF BOF0 KBIF (TI)	PCON1.0 PCON1.1 PCON1.3 PCON1.7

The external interrupt nINT0 and nINT1 can each be either level-activated or transition-activated, depending on bits IT0 and IT1 in register TCON. The flags that actually generate these interrupts are bits IE0 and IE1 in TCON. When an external interrupt is generated, the flag that generated it is cleared by the hardware when the service routine is vectored to *only if the interrupt was transition-activated*, then the external requesting source is what controls the request flag, rather than the on-chip hardware.

The Timer0 and Timer1 interrupts are generated by TF0 and TF1, which are set by a rollover in their respective Timer/Counter registers in most cases. When a timer interrupt is generated, the flag that generated it is cleared by the on-chip hardware when the service routine is vectored to.

The serial port interrupt is generated by the logical OR of RI and TI. Neither of these flags is cleared by hardware when the service routine is vectored to. The service routine should poll RI and TI to determine which one to request service and it will be cleared by software.

The System Flag interrupt is generated by KBIF, BOF0 and WDTF in PCON1. KBIF is set by KBI event. BOF0 is set by on chip Brownout-Detector (BOD0) met the low voltage event. WDTF is set by Watch-Dog-Timer overflow. They will not be cleared by hardware when the service routine is vectored to.

Note: the WDTFIE function is under verifying.

All of the bits that generate interrupts can be set or cleared by software, with the same result as though it had been set or cleared by hardware. In other words, interrupts can be generated or pending interrupts can be canceled in software.

13.3. Interrupt Enable

Table 13–3. Interrupt Enable

No	Source Name	Enable Bit	Bit Location
#1	External Interrupt, nINT0	EX0	IE.0
#2	Timer 0	ET0	IE.1
#3	External Interrupt, nINT1	EX1	IE.2
#4	Timer 1	ET1	IE.3
#5	Serial Port 0	ES0	IE.4
#6	System Flag	ESF & (UTIE, KBIFIE, BOFOIE, WDTFIE)	EIE1.3 & SFIE.7,3,1,0

There are **6** interrupt sources available in **MG86FE/L104**. Each of these interrupt sources can be individually enabled or disabled by setting or clearing an interrupt enable bit in the registers IE and EIE1. IE also contains a global disable bit, EA, which can be cleared to disable all interrupts at once. If EA is set to '1', the interrupts are individually enabled or disabled by their corresponding enable bits. If EA is cleared to '0', all interrupts are disabled.

13.4. Interrupt Priority

The priority scheme for servicing the interrupts is the same as that for the 80C51, except there are four interrupt levels rather than two as on the 80C51. The Priority Bits (see [Table 13–1](#)) determine the priority level of each interrupt. IP0L, IP0H, EIP1L and EIP1H are combined to 4-level priority interrupt. [Table 13–4](#) shows the bit values and priority levels associated with each combination.

Table 13–4. Interrupt Priority

{IPnH.x , IPnL.x}	Priority Level
11	1 (highest)
10	2
01	3
00	4

Each interrupt source has two corresponding bits to represent its priority. One is located in SFR named IPnH and the other in IPnL register. Higher-priority interrupt will be not interrupted by lower-priority interrupt request. If two interrupt requests of different priority levels are received simultaneously, the request of higher priority is serviced. If interrupt requests of the same priority level are received simultaneously, an internal polling sequence determine which request is serviced. [Table 13–2](#) shows the internal polling sequence in the same priority level and the interrupt vector address.

13.5. Interrupt Process

Each interrupt flag is sampled at every system clock cycle. The samples are polled during the next system clock. If one of the flags was in a set condition at first cycle, the second cycle (polling cycle) will find it and the interrupt system will generate an hardware LCALL to the appropriate service routine as long as it is not blocked by any of the following conditions.

Block conditions:

- An interrupt of equal or higher priority level is already in progress.
- The current cycle (polling cycle) is not the final cycle in the execution of the instruction in progress.
- The instruction in progress is RETI or any write to the IE, IP0L, IPH, EIE1, EIP1L and EIP1H registers.

Any of these three conditions will block the generation of the hardware LCALL to the interrupt service routine. Condition 2 ensures that the instruction in progress will be completed before vectoring into any service routine. Condition 3 ensures that if the instruction in progress is RETI or any access to IE or IP, then at least one or more instruction will be executed before any interrupt is vectored to.

13.6. Special Interrupt Vector for TI

The serial port interrupt from TI flag can be masked by BTI (AUXR2.6). If BTI is set, set TI flag will not generate a serial port interrupt. The serial port interrupt only reflects the RI flag.

If UTIE (SFIE.7) is set, TI flag will be combined into System Flag Interrupt. In this mode, TI interrupt shares the interrupt vector with KBIF, BOF0 and WDTF in System Flag Interrupt.

13.7. Interrupt Register

TCON: Timer/Counter Control Register

SFR Page = Normal

SFR Address = 0x88

RESET = 0000-0000

7	6	5	4	3	2	1	0
TF1	TR1	TF0	TR0	IE1	IT1	IE0	IT0
R/W	R/W	R/W	R/W	R/W	R/W	R/W	R/W

Bit 3: IE1, Interrupt 1 Edge flag.

0: Cleared when interrupt processed on if transition-activated.

1: Set by hardware when external interrupt 1 edge is detected (transmitted or level-activated).

Bit 2: IT1: Interrupt 1 Type control bit.

0: Cleared by software to specify low level triggered external interrupt 1. If INT1H (AUXR0.1) is set, this bit specifies high level triggered on nINT1.

1: Set by software to specify falling edge triggered external interrupt 1. If INT1H (AUXR0.1) is set, this bit specifies rising edge triggered on nINT1.

Bit 1: IE0, Interrupt 0 Edge flag.

0: Cleared when interrupt processed on if transition-activated.

1: Set by hardware when external interrupt 0 edge is detected (transmitted or level-activated).

Bit 0: IT0: Interrupt 0 Type control bit.

0: Cleared by software to specify low level triggered external interrupt 0. If INT0H (AUXR0.0) is set, this bit specifies high level triggered on nINT0.

1: Set by software to specify falling edge triggered external interrupt 0. If INT0H (AUXR0.0) is set, this bit specifies rising edge triggered on nINT0.

IE: Interrupt Enable Register

SFR Page = Normal

SFR Address = 0xA8

RESET = 0xx0-0000

7	6	5	4	3	2	1	0
EA	--	--	ES	ET1	EX1	ET0	EX0
R/W	W	W	R/W	R/W	R/W	R/W	R/W

Bit 7: EA, All interrupts enable register.

0: Global disables all interrupts.

1: Global enables all interrupts.

Bit 6: Reserved. Software must write "0" on this bit when IE is written.

Bit 5: Reserved. Software must write "0" on this bit when IE is written.

Bit 4: ES, Serial port interrupt enable register.

0: Disable serial port interrupt.

1: Enable serial port interrupt.

Bit 3: ET1, Timer 1 interrupt enable register.

0: Disable Timer 1 interrupt.

1: Enable Timer 1 interrupt.

Bit 2: EX1, External interrupt 1 enable register.

0: Disable external interrupt 1.

1: Enable external interrupt 1.

Bit 1: ET0, Timer 0 interrupt enable register.

0: Disable Timer 0 interrupt.

1: Enable Timer 1 interrupt.

Bit 0: EX0, External interrupt 0 enable register.
 0: Disable external interrupt 0.
 1: Enable external interrupt 1.

EIE1: Extended Interrupt Enable 1 Register

SFR Page = Normal
 SFR Address = 0xAD RESET = xxxx-0xxx

7	6	5	4	3	2	1	0
--	--	--	--	ESF	--	--	--
W	W	W	W	R/W	W	W	W

Bit 7~4: Reserved. Software must write “0” on these bits when EIE1 is written.

Bit 3: ESF, Enable System Flag interrupt.

0: Disable the interrupt when the group of {KBIF, BOF0, WDTF} in PCON1 or TI in SCON is set
 1: Enable the interrupt of the flags of {KBIF, BOF0, WDTF} in PCON1 or TI in SCON when the associated system flag interrupt is enabled in SFIE.

Bit 2~0: Reserved. Software must write “0” on these bits when EIE1 is written.

SFIE: System Flag Interrupt Enable Register

SFR Page = Normal
 SFR Address = 0x8E RESET = 0xxx-0x00

7	6	5	4	3	2	1	0
UTIE	--	--	--	KBIFIE	--	BOF0IE	WDTFIE
R/W	W	W	W	R/W	W	R/W	R/W

Bit 7: UART TI Enabled in system flag interrupt.

0: Disable the interrupt vector sharing for TI in system flag interrupt.
 1: Set TI flag will share the interrupt vector with system flag interrupt.

Bit 6~4: Reserved. Software must write “0” on these bits when SFIE is written.

Bit 3: KBIFIE, Enable KBIF (PCON1.3) Interrupt.

0: Disable KBIF interrupt.
 1: Enable KBIF interrupt.

Bit 2: Reserved. Software must write “0” on this bit when SFIE is written.

Bit 1: BOF0IE, Enable BOF0 (PCON1.1) Interrupt.

0: Disable BOF0 interrupt.
 1: Enable BOF0 interrupt.

Bit 0: WDTFIE, Enable WDTF (PCON1.0) Interrupt.

0: Disable WDTF interrupt.
 1: Enable WDTF interrupt.

Note: the WDTFIE function is under verifying.

IP0L: Interrupt Priority 0 Low Register

SFR Page = Normal
 SFR Address = 0xB8 RESET = xxx0-0000

7	6	5	4	3	2	1	0
--	--	--	PSL	PT1L	PX1L	PT0L	PX0L
W	W	W	R/W	R/W	R/W	R/W	R/W

Bit 7~5: Reserved. Software must write “0” on these bits when IP0L is written.

Bit 4: PSL, Serial port interrupt priority-L register.
 Bit 3: PT1L, Timer 1 interrupt priority-L register.
 Bit 2: PX1L, external interrupt 1 priority-L register.
 Bit 1: PT0L, Timer 0 interrupt priority-L register.
 Bit 0: PX0L, external interrupt 0 priority-L register.

IP0H: Interrupt Priority 0 High Register

SFR Page = Normal

SFR Address = 0xB7

RESET = xxx0-0000

7	6	5	4	3	2	1	0
--	--	--	PSH	PT1H	PX1H	PT0H	PX0H
W	W	W	R/W	R/W	R/W	R/W	R/W

Bit 7~5: Reserved. Software must write "0" on these bits when IP0H is written.

Bit 4: PSH, Serial port interrupt priority-H register.

Bit 3: PT1H, Timer 1 interrupt priority-H register.

Bit 2: PX1H, external interrupt 1 priority-H register.

Bit 1: PT0H, Timer 0 interrupt priority-H register.

Bit 0: PX0H, external interrupt 0 priority-H register.

EIP1L: Extended Interrupt Priority 1 Low Register

SFR Page = Normal

SFR Address = 0xAE

RESET = xxxx-0xxx

7	6	5	4	3	2	1	0
--	--	--	--	PSFL	--	--	--
W	W	W	W	R/W	W	W	W

Bit 7~4: Reserved. Software must write "0" on these bits when EIP1L is written.

Bit 3: PSFL, system flag interrupt priority-L register.

Bit 2~0: Reserved. Software must write "0" on these bits when EIP1L is written.

EIP1H: Extended Interrupt Priority 1 High Register

SFR Page = Normal

SFR Address = 0xAF

RESET = xxxx-0xxx

7	6	5	4	3	2	1	0
--	--	--	--	PSFH	--	--	--
W	W	W	W	R/W	W	W	W

Bit 7~4: Reserved. Software must write "0" on these bits when EIP1H is written.

Bit 3: PSFH, system flag interrupt priority-H register.

Bit 2~0: Reserved. Software must write "0" on these bits when EIP1H is written.

AUXR0: Auxiliary Register 0

SFR Page = Normal

SFR Address = 0xA1

RESET = 000x-0000

7	6	5	4	3	2	1	0
P40OC1	P40OC0	P40FD	--	P1FS1	P1FS0	INT1H	INT0H
R/W	R/W	R/W	W	R/W	R/W	R/W	R/W

Bit 1: INT1H, INT1 High/Rising trigger enable.

0: Remain INT1 triggered on low level or falling edge on nINT1 port pin.

1: Set INT1 triggered on high level or rising edge on nINT1 port pin.

Bit 0: INT0H, INT0 High/Rising trigger enable.

0: Remain INT0 triggered on low level or falling edge on nINT0 port pin.

1: Set INT0 triggered on high level or rising edge on nINT0 port pin.

13.8. Interrupt Sample Code

(1). Required Function: Set INT0 high level wake-up MCU in power-down mode

Assembly Code Example:	
<pre> ORG 00003h ext_int0_isr: to do..... RETI main: SETB P32 ; ; ORL IP0L,#PX0L ; Select INT0 interrupt priority ORL IP0H,#PX0H ; ; ORL AUXR0,#INT0H ; Set INT0 High level active JB P32,\$; Confirm P3.2 input low SETB EX0 ; Enable INT0 interrupt CLR IE0 ; Clear INT0 flag SETB EA ; Enable global interrupt ORL PCON0,#PD ; Set MCU into Power Down mode</pre>	
C Code Example:	
<pre>void ext_int0_isr(void) interrupt 0 { To do..... } void main(void) { P32 = 1; IP0L = PX0L; // Select INT0 interrupt priority IP0H = PX0H; AUXR0 = INT0H; // Set INT0 High level active while(P32); // Confirm P3.2 input low EX0 = 1; // Enable INT0 interrupt IE0 = 0; // Clear INT0 flag EA = 1; // Enable global interrupt PCON0 = PD; // Set MCU into Power Down mode }</pre>	

14. Timers/Counters

MG86FE/L104 has two Timers/Counters: Timer 0 and Timer 1. Timer 0/1 can be configured as timers or event counters.

In the “timer” function, the timer rate is prescaled by 12 clock cycle to increment register value. In other words, it is to count the standard C51 machine cycle. AUXR2.T0X12 and AUXR2.T1X12 are the function for Timer 0/1 to set the timer rate on every clock cycle.

In the “counter” function, the register is incremented in response to a 1-to-0 transition at its corresponding external input pin, T0 or T1. In this function, the external input is sampled by every timer rate cycle. When the samples show a high in one cycle and a low in the next cycle, the count is incremented. The new count value appears in the register at the end of the cycle following the one in which the transition was detected.

14.1. Timer0 and Timer1

14.1.1. Mode 0 Structure

The timer register is configured as a 13-bit register. As the count rolls over from all 1s to all 0s, it sets the timer interrupt flag TFX. The counted input is enabled to the timer when TRx = 1 and either GATE=0 or INTx = 1. Mode 0 operation is the same for Timer0 and Timer1.

Figure 14–1. Timer 0/1 Mode 0 Structure

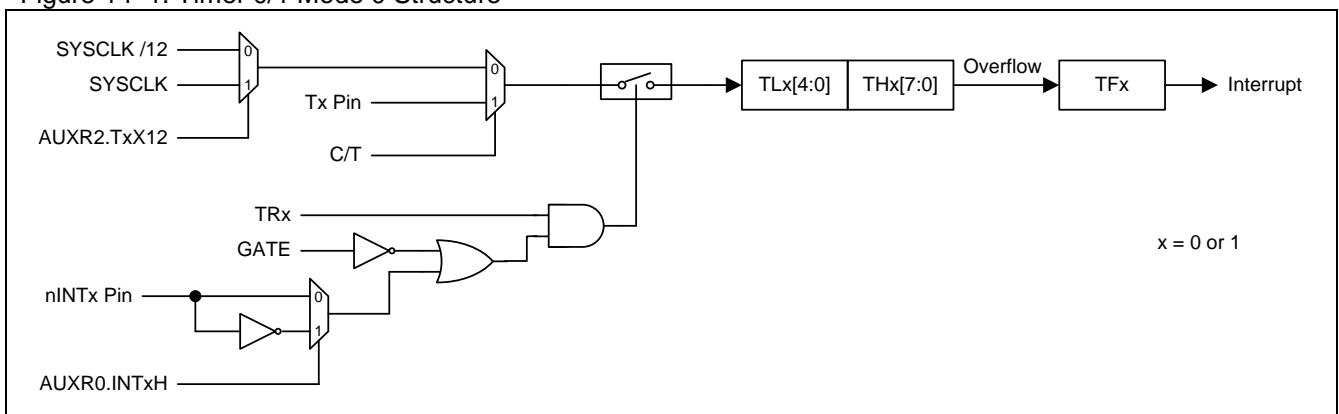

14.1.2. Mode 1 Structure

Mode1 is the same as Mode0, except that the timer register is being run with all 16 bits.

Figure 14–2. Timer 0/1 Mode 1 Structure

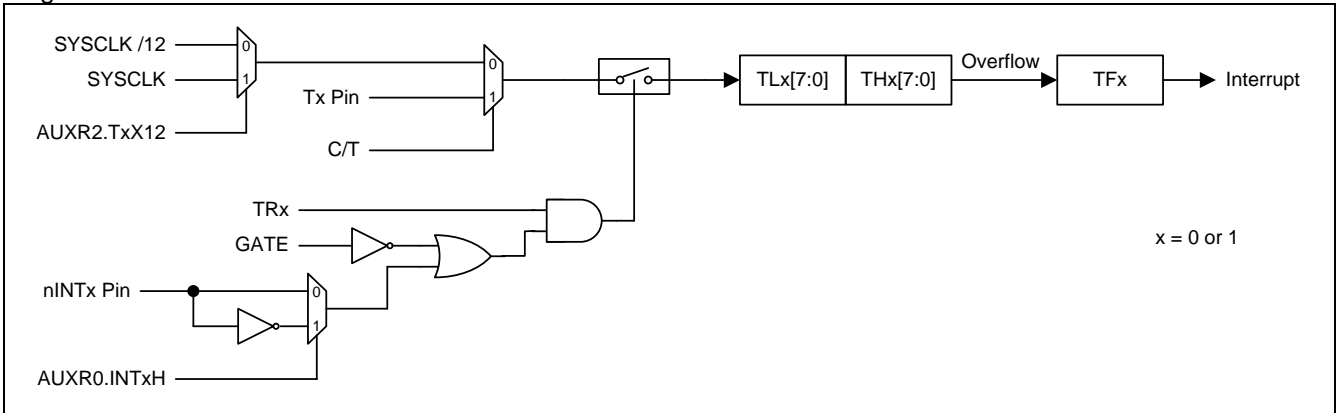

14.1.3. Mode 2 Structure

Mode 2 configures the timer register as an 8-bit counter(TLx) with automatic reload. Overflow from TLx not only set TFX, but also reload TLx with the content of THx, which is determined by software. The reload leaves THx unchanged. Mode 2 operation is the same for Timer0 and Timer1.

Figure 14–3. Timer 0/1 Mode 2 Structure

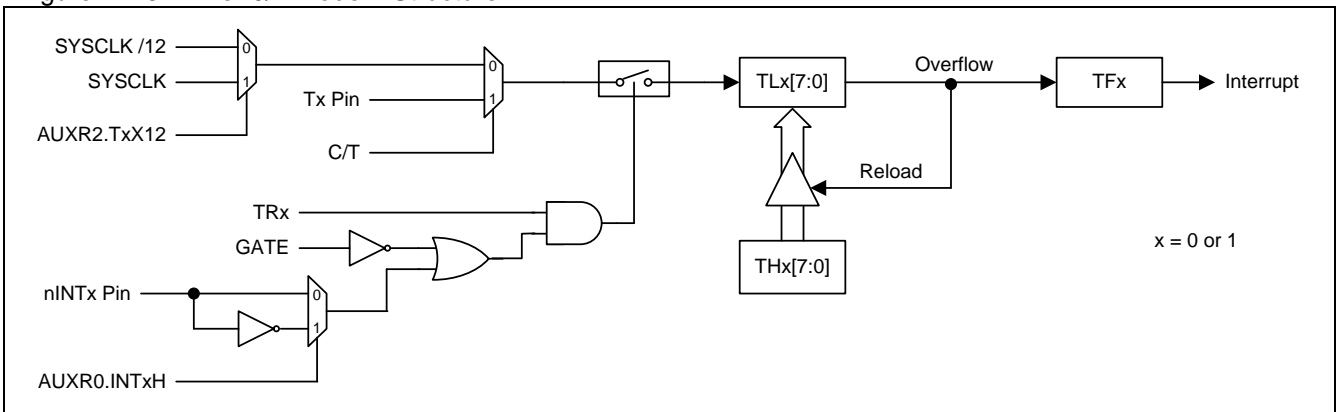

14.1.4. Mode 3 Structure

Timer1 in Mode3 simply holds its count, the effect is the same as setting TR1 = 1. Timer0 in Mode 3 enables TL0 and TH0 as two separate 8-bit counters. TL0 uses the Timer0 control bits such like C/T, GATE, TR0, INT0 and TF0. TH0 is locked into a timer function (can not be external event counter) and take over the use of TR1, TF1 from Timer1. TH0 now controls the Timer1 interrupt.

Figure 14–4. Timer 0/1 Mode 3 Structure

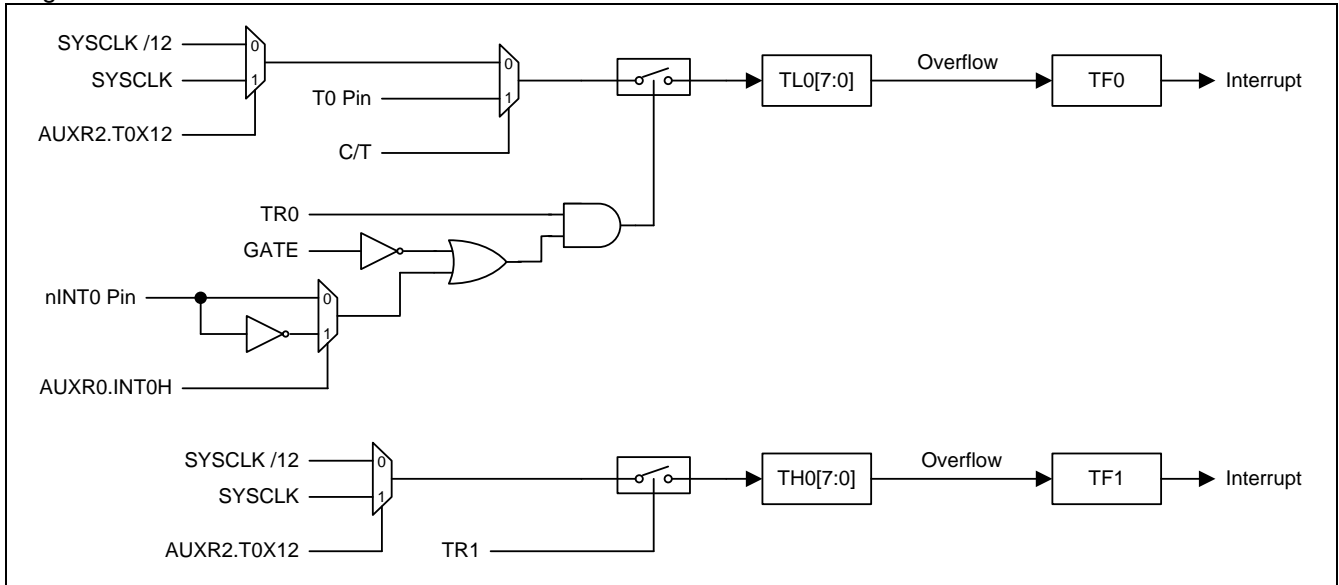

14.1.5. Timer 0/1 Programmable Clock-Out

Timer 0 and Timer 1 have a Clock-Out Mode (while C/Tx=0 & TxCKOE=1). In this mode, Timer 0 or Timer 1 operates as 8-bit auto-reload timer for a programmable clock generator with 50% duty-cycle. The generated clocks come out on P3.4 (T0CKO) and P3.5 (T1CKO) individually. The input clock (SYSCLK/12 or SYSCLK) increments the 8-bit timer (TL0 or TL1). The timer repeatedly counts to overflow from a loaded value. Once overflows occur, the contents of (TH0 and TH1) are loaded into (TL0, TL1) for the consecutive counting. The following formula gives the clock-out frequency:

$$\text{T0/T1 Clock-out Frequency} = \frac{\text{SYSCLK Frequency}}{n \times (256 - \text{THx})}$$

; n=24, if TxX12=0
; n=2, if TxX12=1
; x = 0 or 1 & C/T = 0

Note:

- (1) Timer 0/1 overflow flag, TF0/1, will be set when Timer 0/1 overflows but not generate interrupt.
- (2) For SYSCLK=12MHz & TxX12=0, Timer 0/1 has a programmable output frequency range from 1.95KHz to 500KHz.
- (3) For SYSCLK=12MHz & TxX12=1, Timer 0/1 has a programmable output frequency range from 23.43KHz to 6MHz.

Figure 14–5. Timer 0/1 in Clock Output Mode

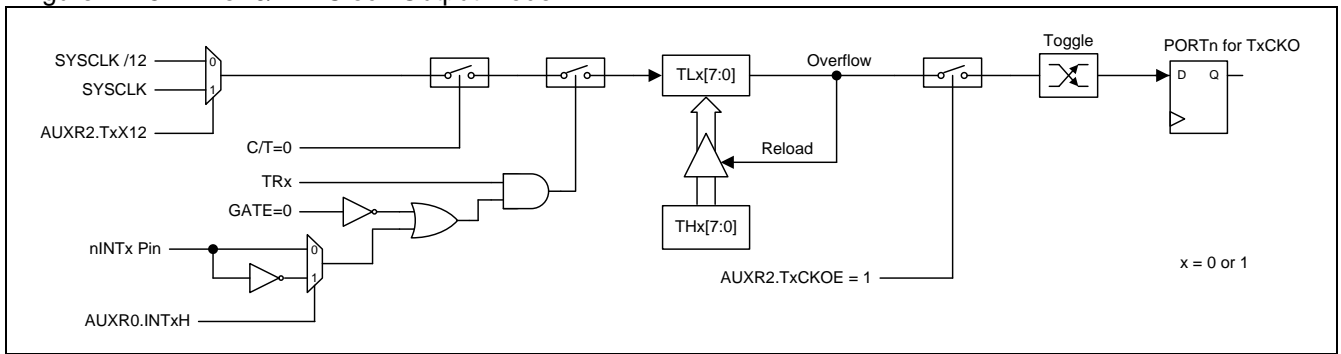

How to Program Timer 0/1 in Clock-out Mode

- Select T0X12/T1X12 bit in AUXR2 register to decide the Timer 0/1 clock source.
- Set T0CKOE/T1CKOE bit in AUXR2 register.
- Clear C/T bit in TMOD register.
- Determine the 8-bit reload value from the formula and enter it in the TH0/TH1 register.
- Enter the same reload value as the initial value in the TL0/TL1 register.
- Set TR0/TR1 bit in TCON register to start the Timer 0/1.

In the Clock-Out mode, Timer 0/1 rollovers will not generate an interrupt. This is similar to when Timer 1 is used as a baud-rate generator. It is possible to use Timer 1 as a baud rate generator and a clock generator simultaneously. Note, however, that the baud-rate and the clock-out frequency depend on the same overflow rate of Timer 1.

14.1.6. Timer0/1 Register

TCON: Timer/Counter Control Register

SFR Page = Normal

SFR Address = 0x88

RESET = 0000-0000

7	6	5	4	3	2	1	0
TF1	TR1	TF0	TR0	IE1	IT1	IE0	IT0
R/W	R/W	R/W	R/W	R/W	R/W	R/W	R/W

Bit 7: TF1, Timer 1 overflow flag.

0: Cleared by hardware when the processor vectors to the interrupt routine, or cleared by software.

1: Set by hardware on Timer/Counter 1 overflow, or set by software.

Bit 6: TR1, Timer 1 Run control bit.

0: Cleared by software to turn Timer/Counter 1 off.

1: Set by software to turn Timer/Counter 1 on.

Bit 5: TF0, Timer 0 overflow flag.

0: Cleared by hardware when the processor vectors to the interrupt routine, or cleared by software.

1: Set by hardware on Timer/Counter 0 overflow, or set by software.

Bit 4: TR0, Timer 0 Run control bit.

0: Cleared by software to turn Timer/Counter 0 off.

1: Set by software to turn Timer/Counter 0 on.

TMOD: Timer/Counter Mode Control Register

SFR Page = Normal

SFR Address = 0x89

RESET = 0000-0000

7	6	5	4	3	2	1	0
GATE	C/T	M1	M0	GATE	C/T	M1	M0
R/W	R/W	R/W	R/W	R/W	R/W	R/W	R/W

|←----- Timer1 ----->|←----- Timer0 ----->|

Bit 7/3: Gate, Gating control for Timer1/0.

0: Disable gating control for Timer1/0.

1: Enable gating control for Timer1/0. When set, Timer1/0 or Counter1/0 is enabled only when /INT1 or /INT0 pin is high and TR1 or TR0 control bit is set.

Bit 6/2: C/T, Timer for Counter function selector.

0: Clear for Timer operation, input from internal system clock.

1: Set for Counter operation, input from T1 input pin.

Bit 5~4/1~0: Operating mode selection.

M1	M0	Operating Mode
0	0	13-bit timer/counter for Timer0 and Timer1
0	1	16-bit timer/counter for Timer0 and Timer1
1	0	8-bit timer/counter with automatic reload for Timer0 and Timer1
1	1 (Timer0)	TL0 is 8-bit timer/counter, TH0 is locked into 8-bit timer
1	1 (Timer1)	Timer/Counter1 Stopped

TL0: Timer Low 0 Register

SFR Page = Normal

SFR Address = 0x8A RESET = 0000-0000

7	6	5	4	3	2	1	0
TL0.7	TL0.6	TL0.5	TL0.4	TL0.3	TL0.2	TL0.1	TL0.0
R/W	R/W	R/W	R/W	R/W	R/W	R/W	R/W

TH0: Timer High 0 Register

SFR Page = Normal

SFR Address = 0x8C RESET = 0000-0000

7	6	5	4	3	2	1	0
TH0.7	TH0.6	TH0.5	TH0.4	TH0.3	TH0.2	TH0.1	TH0.0
R/W	R/W	R/W	R/W	R/W	R/W	R/W	R/W

TL1: Timer Low 1 Register

SFR Page = Normal

SFR Address = 0x8B RESET = 0000-0000

7	6	5	4	3	2	1	0
TL1.7	TL1.6	TL1.5	TL1.4	TL1.3	TL1.2	TL1.1	TL1.0
R/W	R/W	R/W	R/W	R/W	R/W	R/W	R/W

TH1: Timer High 1 Register

SFR Page = Normal

SFR Address = 0x8D RESET = 0000-0000

7	6	5	4	3	2	1	0
TH1.7	TH1.6	TH1.5	TH1.4	TH1.3	TH1.2	TH1.1	TH1.0
R/W	R/W	R/W	R/W	R/W	R/W	R/W	R/W

AUXR2: Auxiliary Register 2

SFR Page = Normal

SFR Address = 0xA3 RESET = 0000-0000

7	6	5	4	3	2	1	0
URXR	BTI	URM0X6	SMOD2	T1X12	T0X12	T1CKOE	T0CKOE
R/W	R/W	R/W	R/W	R/W	R/W	R/W	R/W

Bit 3: T1X12, Timer 1 clock source selector while C/T=0.

0: Clear to select SYSCLK/12.

1: Set to select SYSCLK as the clock source.

Bit 2: T0X12, Timer 0 clock source selector while C/T=0.

0: Clear to select SYSCLK/12.

1: Set to select SYSCLK as the clock source.

Bit 1: T1CKOE, Timer 1 Clock Output Enable.

0: Disable Timer 1 clock output.

1: Enable Timer 1 clock output on P3.5.

Bit 0: T0CKOE, Timer 0 Clock Output Enable.

0: Disable Timer 0 clock output.

1: Enable Timer 0 clock output on P3.4.

14.1.7. Timer0/1 Sample Code

(1). Required Function: IDLE mode with T0 wake-up frequency 320Hz, SYSCLK = ILRCO

Assembly Code Example:	
<pre> ORG 0000Bh time0_isr: to do... RETI main: ; (unsigned short value) //Switch Sysclk to ILRCO MOV IFADRL,#(CKCON2) ; Index Page-P address to CKCON2 CALL _page_p_sfr_read ; Read CKCON2 data ANL IFD,#~(OSCS1 OSCS0) ; Switch OSCin source to ILRCO ORL IFD,#(OSCS1) CALL _page_p_sfr_write ; Write data to CKCON2 ANL IFD,#~(XTALE IHRCOE) ; Disable XTAL and IHRCO CALL _page_p_sfr_write ; Write data to CKCON2 MOV IFADRL,#(DCON0) ; Index Page-P address to DCON0 CALL _page_p_sfr_read ; Read DCON0 data ANL IFD,#~(HSE) ; Disable HSE when SYSCLK ≤ 6MHz for power saving CALL _page_p_sfr_write ; Write data to DCON0 ANL CKCON0,#(AFS) ; Select SCKS[2:0] = 0 = OSCin/1 ORL AUXR2,#T0X12 ; Select SYSCLK/1 for Timer 0 clock input ANL AUXR0,#~T0XL ; MOV TH0,#(256-100) ; Set Timer 0 overflow rate = SYSCLK x 100 MOV TL0,#(256-100) ; ANL TMOD,#(0F0h T0M1) ; Set Timer 0 to Mode 2 ORL TMOD,#T0M1 ; CLR TF0 ; Clear Timer 0 Flag ORL IP0L,#PT0L ; Select Timer 0 interrupt priority ORL IP0H,#PT0H ; SETB ET0 ; Enable Timer 0 interrupt SETB EA ; Enable global interrupt SETB TR0 ; Start Timer 0 running ORL PCON0,#IDL ; Set MCU into IDLE mode </pre>	
C Code Example:	
<pre> void time0_isr(void) interrupt 1 { To do... } void main(void) { IFADRL = CKCON2; // Index Page-P address to CKCON2 page_p_sfr_read(); // Read CKCON2 data. IFD = ~(OSCS1 OSCS0); // Switch OSCin source to ILRCO IFD = OSCS1; page_p_sfr_write(); // Write data to CKCON2 } </pre>	

```

IFD &= ~(XTALE | IHRCOE);           // Disable XTAL and IHRCO
page_p_sfr_write();                 // Write data to CKCON2

IFADRL = DCON0;                     // Index Page-P address to DCON0
page_p_sfr_read();                 // Read DCON0 data

IFD &= ~HSE;                         // Disable HSE when SYSCLK ≤ 6MHz for power saving
page_p_sfr_write();                 // Write data to DCON0

CKCON0 &= AFS;                       // Select SCKS[2:0] = 0 = OSCin/1

AUXR2 |= T0X12;                     // Select SYSCLK/1 for Timer 0 clock input
AUXR0 &= ~T0XL;

TH0 = TL0 = (256-100);              // Set Timer 0 overflow rate = SYSCLK x 100
TMOD &= 0xF0;                       // Set Timer 0 to Mode 2
TMOD |= T0M1;                       // Clear Timer 0 Flag
TF0 = 0;

IP0L |= PT0L;                       // Select Timer 0 interrupt priority
IP0H |= PT0H;

ET0 = 1;                             // Enable Timer 0 interrupt
EA = 1;                               // Enable global interrupt

TR0 = 1;                             // Start Timer 0 running

PCON0=IDL;                           // Set MCU into IDLE mode
}

```

(2). Required Function: Set Timer 0 clock output by SYSCLK/48 input

Assembly Code Example:

```

CLR    TR0                            ;

ANL    P3M0,#0EFh                     ; Set P3.4(T0CKO) to push-pull output
ORL    P3M1,#010h                     ;
ORL    AUXR2,#T0CKOE                  ; Enable T0CKO

ANL    AUXR2,#~T0X12                  ; Select SYSCLK/48 for Timer 0 clock input
ORL    AUXR0,#T0XL                    ;

MOV    TH0,#0FFh                      ;
MOV    TL0,#0FFh                      ;

ANL    TMOD,#0F0h                     ; Set Timer 0 to Mode 2
ORL    TMOD,#T0M1                     ;

SETB   TR0                            ; Start Timer 0 running

```

C Code Example:

```

TR0 = 0;

P3M0 &= 0xEF;                         // Set P3.4(T0CKO) to push-pull output
P3M1 |= 0x10;
AUXR2 |= T0CKOE;                       // Enable T0CKO

AUXR2 &= ~T0X12;                       // Select SYSCLK/48 for Timer 0 clock input
AUXR0 |= T0XL;

TH0 = TL0 = 0xFF;

TMOD &= 0xF0;                           // Set Timer 0 to Mode 2
TMOD |= T0M1;

TR0 = 1;                               // Start Timer 0 running

```

(3). Required Function: Set Timer 1 clock output by SYSCLK input

Assembly Code Example:

```
ORL    P3M1,#020h           ; Set P3.5(T1CKO) to push-pull output
ANL    P3M0,#0DFh           ;
;

ORL    AUXR2,#(T1X12|T1CKOE) ; Select SYSCLK for Timer 1 clock input
; Enable T1CKO

MOV    TH1,#0FFh           ;
MOV    TL1,#0FFh           ;

ANL    TMOD,#00Fh          ; Set Timer 1 to Mode 2
ORL    TMOD,#T1M1          ;

SETB   TR1                  ; Start Timer 1 running
```

C Code Example:

```
P3M1 |= 0x20;                // Set P3.5(T1CKO) to push-pull output
P3M0 &= 0xDF;

AUXR2 |= (T1X12|T1CKOE);    // Select SYSCLK for Timer 1 clock input
// Enable T1CKO

TH1 = TL1 = 0xFF;

TMOD &= 0x0F;                // Set Timer 1 to Mode 2
TMOD |= T1M1;

TR1 = 1;                     // Start Timer 1 running
```

15. Serial Port (UART)

The serial port of **MG86FE/L104** support full-duplex transmission, meaning it can transmit and receive simultaneously. It is also receive-buffered, meaning it can commence reception of a second byte before a previously received byte has been read from the register. However, if the first byte still hasn't been read by the time reception of the second byte is complete, one of the bytes will be lost. The serial port receive and transmit registers are both accessed at special function register SBUF. Writing to SBUF loads the transmit register, and reading from SBUF accesses a physically separate receive register.

The serial port can operate in 4 modes: Mode 0 provides *synchronous* communication while Modes 1, 2, and 3 provide *asynchronous* communication. The asynchronous communication operates as a full-duplex Universal Asynchronous Receiver and Transmitter (UART), which can transmit and receive simultaneously and at different baud rates.

Mode 0: 8 data bits (LSB first) are transmitted or received through RXD(P3.0). TXD(P3.1) always outputs the shift clock. The baud rate can be selected to 1/12 or 1/2 the system clock frequency by URM0X6 setting in AUXR2 register.

Mode 1: 10 bits are transmitted through TXD or received through RXD. The frame data includes a start bit (0), 8 data bits (LSB first), and a stop bit (1), as shown in [Figure 15–1](#). On receive, the stop bit would be loaded into RB8 in SCON register. The baud rate is variable.

Figure 15–1. Mode 1 Data Frame

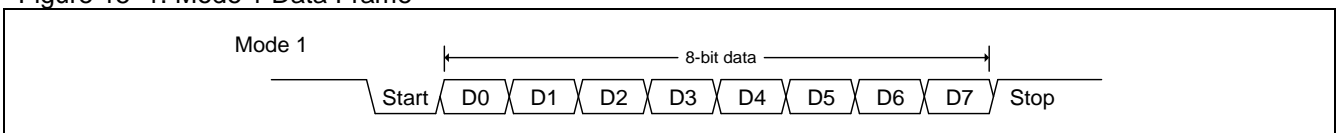

Mode 2: 11 bits are transmitted through TXD or received through RXD. The frame data includes a start bit (0), 8 data bits (LSB first), a programmable 9th data bit, and a stop bit (1), as shown in [Figure 15–2](#). On Transmit, the 9th data bit comes from TB8 in SCON register can be assigned the value of 0 or 1. On receive, the 9th data bit would be loaded into RB8 in SCON register, while the stop bit is ignored. The baud rate can be configured to 1/32 or 1/64 the system clock frequency.

Figure 15–2. Mode 2, 3 Data Frame

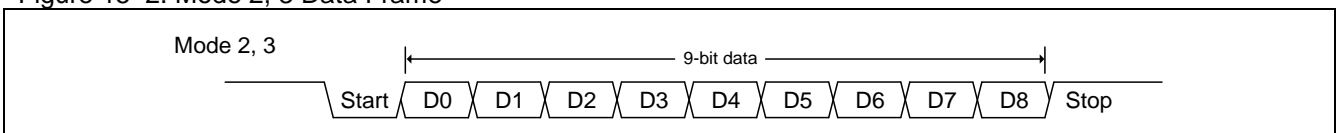

Mode 3: Mode 3 is the same as Mode 2 except the baud rate is variable.

In all four modes, transmission is initiated by any instruction that uses SBUF as a destination register. In Mode 0, reception is initiated by the condition RI=0 and REN=1. In the other modes, reception is initiated by the incoming start bit with 1-to-0 transition if REN=1.

In addition to the standard operation, the UART can perform framing error detection by looking for missing stop bits, and automatic address recognition.

15.1. Serial Port Mode 0

Serial data enters and exits through RXD. TXD outputs the shift clock. 8 bits are transmitted/received: 8 data bits (LSB first). The shift clock source can be selected to 1/12 or 1/2 the system clock frequency by URM0X6 setting in AUXR2 register. Figure 15–3 shows a simplified functional diagram of the serial port in Mode 0.

Transmission is initiated by any instruction that uses SBUF as a destination register. The “write to SBUF” signal triggers the UART engine to start the transmission. The data in the SBUF would be shifted into the RXD(P3.0) pin by each raising edge shift clock on the TXD(P3.1) pin. After eight raising edge of shift clocks passing, TI would be asserted by hardware to indicate the end of transmission. Figure 15–4 shows the transmission waveform in Mode 0.

Reception is initiated by the condition REN=1 and RI=0. At the next instruction cycle, the Serial Port Controller writes the bits 11111110 to the receive shift register, and in the next clock phase activates Receive.

Receive enables Shift Clock which directly comes from RX Clock to the alternate output function of P3.1 pin. When Receive is active, the contents on the RXD(P3.0) pin would be sampled and shifted into shift register by falling edge of shift clock. After eight falling edge of shift clock, RI would be asserted by hardware to indicate the end of reception. Figure 15–5 shows the reception waveform in Mode 0.

Figure 15–3. Serial Port 0 Mode 0

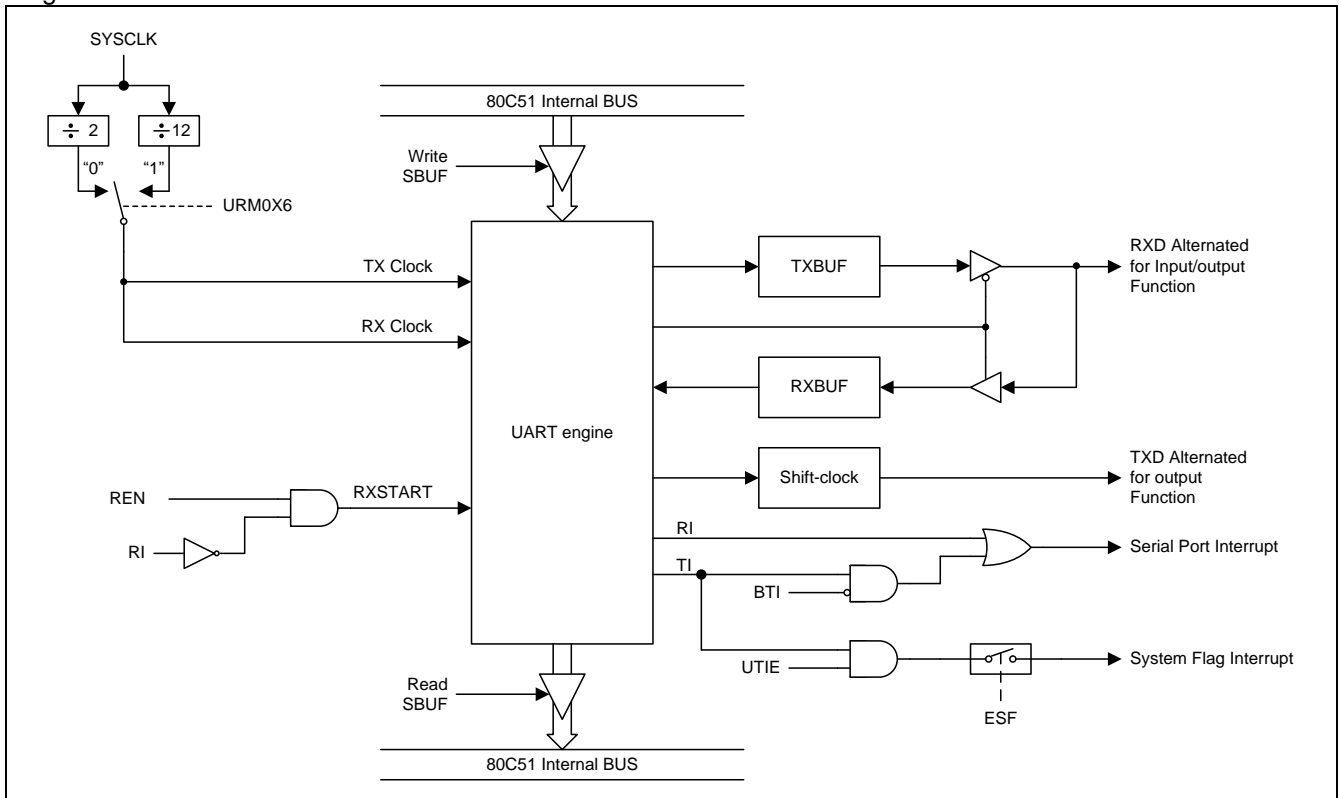

Figure 15–4. Mode 0 Transmission Waveform

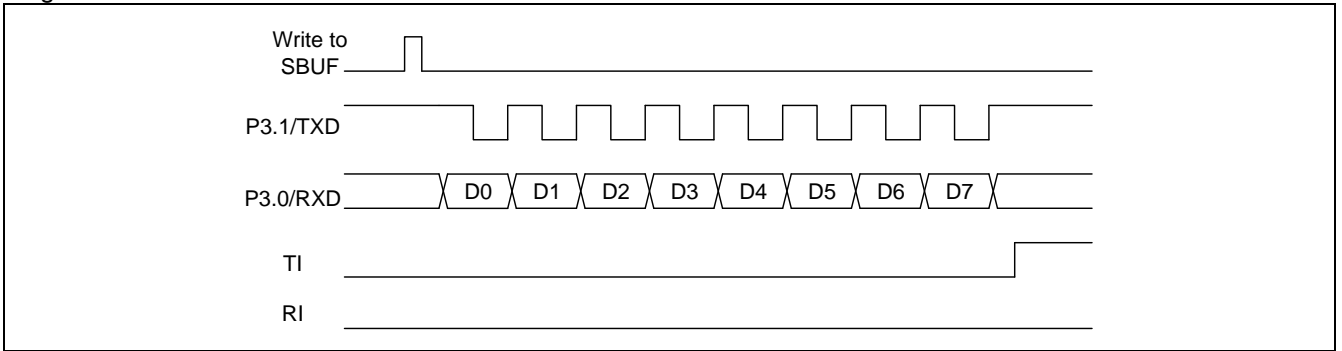
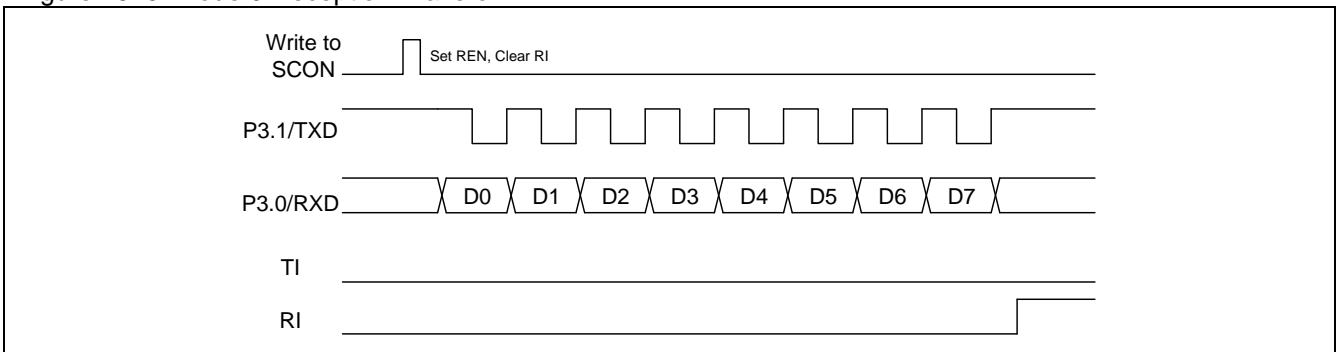

Figure 15–5. Mode 0 Reception Waveform



15.2. Serial Port Mode 1

10 bits are transmitted through TXD, or received through RXD: a start bit (0), 8 data bits (LSB first), and a stop bit (1). On receive, the stop bit goes into RB8 in SCON. The baud rate is determined by the Timer 1 overflow rate. Figure 15–1 shows the data frame in Mode 1 and Figure 15–6 shows a simplified functional diagram of the serial port in Mode 1.

Transmission is initiated by any instruction that uses SBUF as a destination register. The “write to SBUF” signal requests the UART engine to start the transmission. After receiving a transmission request, the UART engine would start the transmission at the raising edge of TX Clock. The data in the SBUF would be serial output on the TXD pin with the data frame as shown in Figure 15–1 and data width depend on TX Clock. After the end of 8th data transmission, TI would be asserted by hardware to indicate the end of data transmission.

Reception is initiated when Serial Port Controller detected 1-to-0 transition at RXD sampled by RCK. The data on the RXD pin would be sampled by Bit Detector in Serial Port Controller. After the end of STOP-bit reception, RI would be asserted by hardware to indicate the end of data reception and load STOP-bit into RB8 in SCON register.

Figure 15–6. Serial Port Mode 1, 2, 3

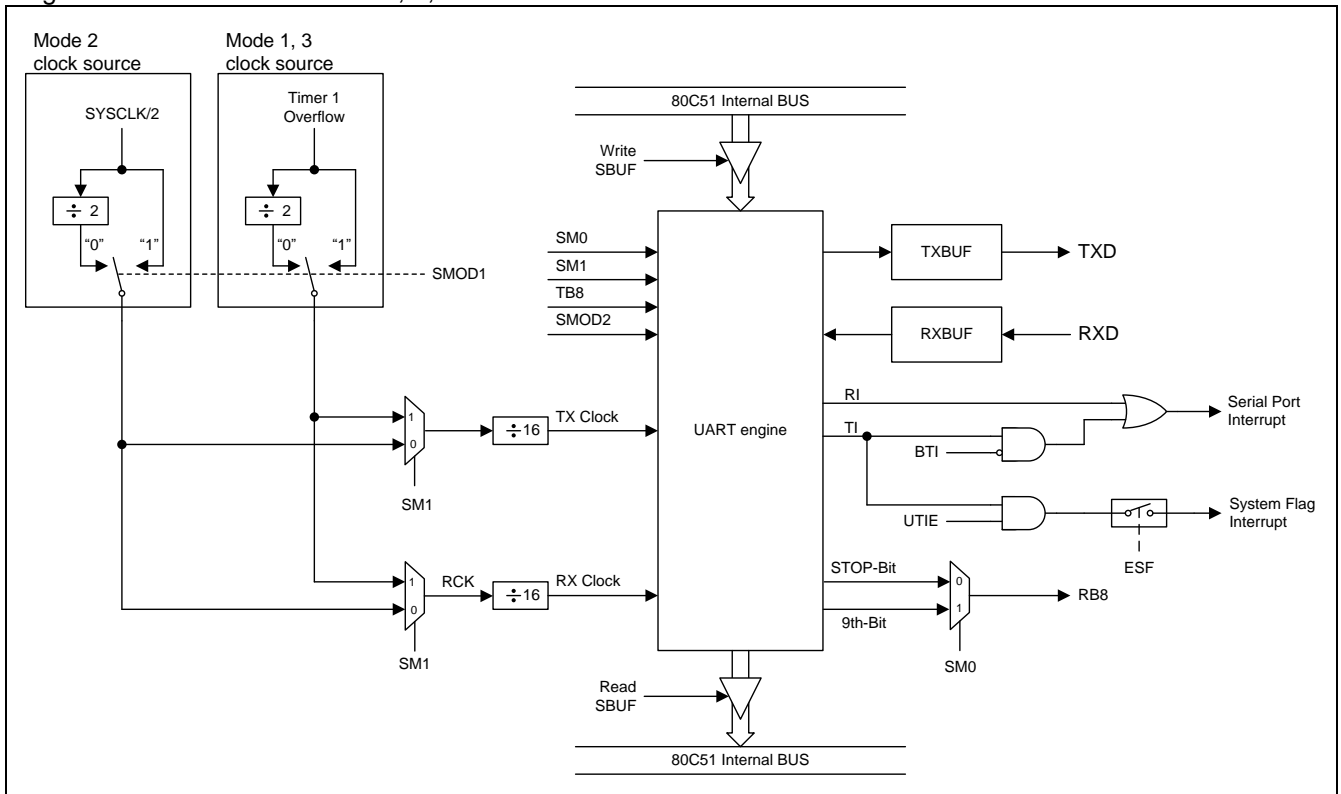

15.3. Serial Port Mode 2 and Mode 3

11 bits are transmitted through TXD, or received through RXD: a start bit (0), 8 data bits (LSB first), a programmable 9th data bit, and a stop bit (1). On transmit, the 9th data bit (TB8) can be assigned the value of 0 or 1. On receive, the 9th data bit goes into RB8 in SCON. The baud rate is programmable to select one of 1/16, 1/32 or 1/64 the system clock frequency in Mode 2. Mode 3 may have a variable baud rate generated from Timer 1 or Timer 2.

Figure 15–2 shows the data frame in Mode 2 and Mode 3. Figure 15–6 shows a functional diagram of the serial port in Mode 2 and Mode 3. The receive portion is exactly the same as in Mode 1. The transmit portion differs from Mode 1 only in the 9th bit of the transmit shift register.

The “write to SBUF” signal requests the Serial Port Controller to load TB8 into the 9th bit position of the transmit shift register and starts the transmission. After receiving a transmission request, the UART engine would start the transmission at the raising edge of TX Clock. The data in the SBUF would be serial output on the TXD pin with the data frame as shown in Figure 15–2 and data width depend on TX Clock. After the end of 9th data transmission, TI would be asserted by hardware to indicate the end of data transmission.

Reception is initiated when the UART engine detected 1-to-0 transition at RXD sampled by RCK. The data on the RXD pin would be sampled by Bit Detector in UART engine. After the end of 9th data bit reception, RI would be asserted by hardware to indicate the end of data reception and load the 9th data bit into RB8 in SCON register.

In all four modes, transmission is initiated by any instruction that use SBUF as a destination register. Reception is initiated in mode 0 by the condition RI = 0 and REN = 1. Reception is initiated in the other modes by the incoming start bit with 1-to-0 transition if REN=1.

15.4. Frame Error Detection

When used for framing error detection, the UART looks for missing stop bits in the communication. A missing stop bit will set the FE bit in the SCON register. The FE bit shares the SCON.7 bit with SM0 and the function of SCON.7 is determined by SMOD0 bit (PCON.6). If SMOD0 is set then SCON.7 functions as FE. SCON.7 functions as SM0 when SMOD0 is cleared. When SCON.7 functions as FE, it can only be cleared by firmware. Refer to Figure 15–7.

Figure 15–7. UART0 Frame Error Detection

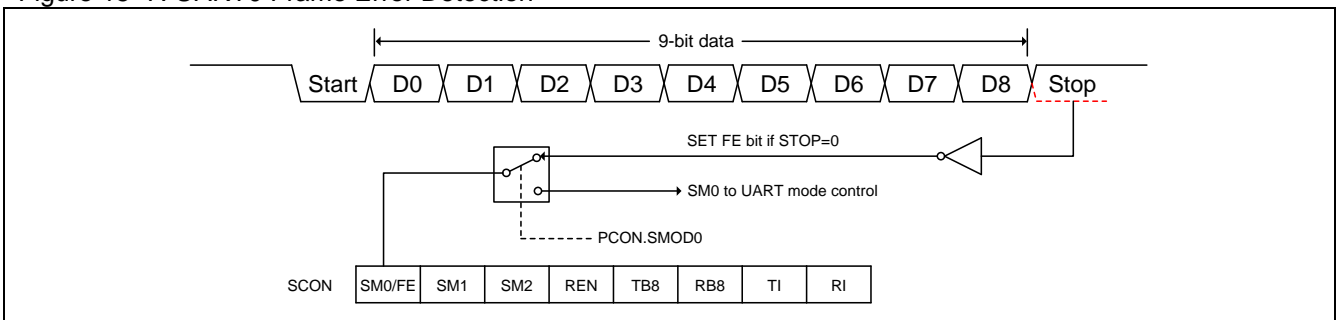

15.5. Multiprocessor Communications

Modes 2 and 3 have a special provision for multiprocessor communications as shown in Figure 15–8. In these two modes, 9 data bits are received. The 9th bit goes into RB8. Then comes a stop bit. The port can be programmed such that when the stop bit is received, the serial port interrupt will be activated only if RB8=1. This feature is enabled by setting bit SM2 (in SCON register). A way to use this feature in multiprocessor systems is as follows:

When the master processor wants to transmit a block of data to one of several slaves, it first sends out an address byte which identifies the target slave. An address byte differs from a data byte in that the 9th bit is 1 in an address byte and 0 in a data byte. With SM2=1, no slave will be interrupted by a data byte. An address byte, however, will interrupt all slaves, so that each slave can examine the received byte and check if it is being addressed. The addressed slave will clear its SM2 bit and prepare to receive the data bytes that will be coming. The slaves that weren't being addressed leave their SM2 set and go on about their business, ignoring the coming data bytes.

SM2 has no effect in Mode 0, and in Mode 1 can be used to check the validity of the stop bit. In a Mode 1 reception, if SM2=1, the receive interrupt will not be activated unless a valid stop bit is received.

Figure 15–8. UART0 Multiprocessor Communications

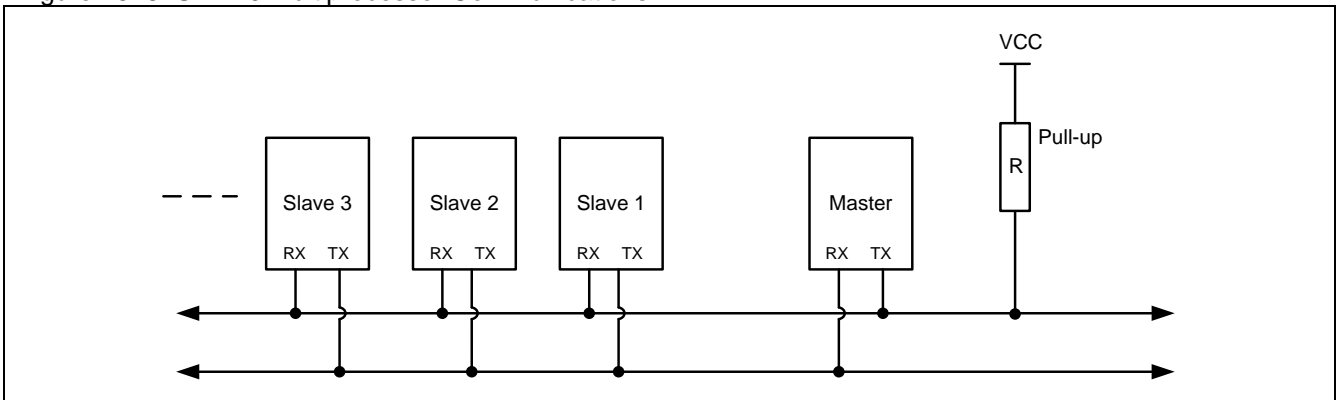

15.6. Automatic Address Recognition

Automatic Address Recognition is a feature which allows the UART to recognize certain addresses in the serial bit stream by using hardware to make the comparisons. This feature saves a great deal of firmware overhead by eliminating the need for the firmware to examine every serial address which passes by the serial port. This feature is enabled by setting the SM2 bit in SCON.

In the 9 bit UART modes, mode 2 and mode 3, the Receive Interrupt flag (RI) will be automatically set when the received byte contains either the “Given” address or the “Broadcast” address. The 9-bit mode requires that the 9th information bit is a 1 to indicate that the received information is an address and not data. Automatic address recognition is shown in Figure 15–9. The 8 bit mode is called Mode 1. In this mode the RI flag will be set if SM2 is enabled and the information received has a valid stop bit following the 8 address bits and the information is either a Given or Broadcast address. Mode 0 is the Shift Register mode and SM2 is ignored.

Using the Automatic Address Recognition feature allows a master to selectively communicate with one or more slaves by invoking the Given slave address or addresses. All of the slaves may be contacted by using the Broadcast address. Two special Function Registers are used to define the slave’s address, SADDR, and the address mask, SADEN.

SADEN is used to define which bits in the SADDR are to be used and which bits are “don’t care”. The SADEN mask can be logically ANDed with the SADDR to create the “Given” address which the master will use for addressing each of the slaves. Use of the Given address allows multiple slaves to be recognized while excluding others.

The following examples will help to show the versatility of this scheme:

Slave 0	Slave 1
SADDR = 1100 0000	SADDR = 1100 0000
SADEN = 1111 1101	SADEN = 1111 1110
Given = 1100 00X0	Given = 1100 000X

In the above example SADDR is the same and the SADEN data is used to differentiate between the two slaves. Slave 0 requires a 0 in bit 0 and it ignores bit 1. Slave 1 requires a 0 in bit 1 and bit 0 is ignored. A unique address for Slave 0 would be 1100 0010 since slave 1 requires a 0 in bit 1. A unique address for slave 1 would be 1100 0001 since a 1 in bit 0 will exclude slave 0. Both slaves can be selected at the same time by an address which has bit 0 = 0 (for slave 0) and bit 1 = 0 (for slave 1). Thus, both could be addressed with 1100 0000.

In a more complex system the following could be used to select slaves 1 and 2 while excluding slave 0:

Slave 0	Slave 1	Slave 2
SADDR = 1100 0000	SADDR = 1110 0000	SADDR = 1110 0000
SADEN = 1111 1001	SADEN = 1111 1010	SADEN = 1111 1100
Given = 1100 0XX0	Given = 1110 0X0X	Given = 1110 00XX

In the above example the differentiation among the 3 slaves is in the lower 3 address bits. Slave 0 requires that bit 0 = 0 and it can be uniquely addressed by 1110 0110. Slave 1 requires that bit 1 = 0 and it can be uniquely addressed by 1110 0101. Slave 2 requires that bit 2 = 0 and its unique address is 1110 0011. To select Slaves 0 and 1 and exclude Slave 2 use address 1110 0100, since it is necessary to make bit 2 = 1 to exclude slave 2.

The Broadcast Address for each slave is created by taking the logical OR of SADDR and SADEN. Zeros in this result are treated as don't-cares. In most cases, interpreting the don't-cares as ones, the broadcast address will be FF hexadecimal.

Upon reset SADDR (SFR address 0xA9) and SADEN (SFR address 0xB9) are loaded with 0s. This produces a given address of all "don't cares" as well as a Broadcast address of all "don't cares". This effectively disables the Automatic Addressing mode and allows the micro-controller to use standard 80C51 type UART drivers which do not make use of this feature.

Figure 15-9. Auto-Address Recognition

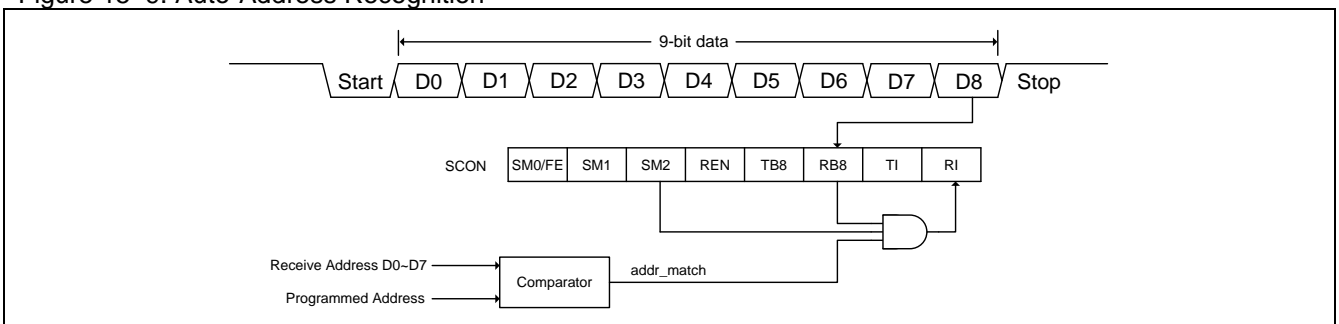

Note: (1) After address matching(addr_match=1), Clear SM2 to receive data bytes
 (2) After all data bytes have been received, Set SM2 to wait for next address.

15.7. Baud Rate Setting

Bits T1X12, URM0X6 and SMOD2 in AUXR2 register provide a new option for the baud rate setting, as listed below.

15.7.1. Baud Rate in Mode 0

$$\text{Mode 0 Baud Rate} = \frac{F_{\text{SYSCLK}}}{n} \quad ; n=12, \text{ if URM0X6}=0 \\ ; n=2, \text{ if URM0X6}=1$$

Note:

If URM0X6=0, the baud rate formula is as same as standard 8051.

15.7.2. Baud Rate in Mode 2

$$\text{Mode 2 Baud Rate} = \frac{2^{\text{SMOD1}} \times 2^{(\text{SMOD2} \times 2)}}{64} \times (F_{\text{SYSCLK}})$$

Note:

If SMOD2=0, the baud rate formula is as same as standard 8051. If SMOD2=1, there is an enhanced function for baud rate setting. [Table 15–1](#) defines the Baud Rate setting with SMOD2 factor in Mode 2 baud rate generator.

Table 15–1. SMOD2 application criteria in Mode 2

SMOD2	SMOD1	Baud Rate	Note	Recommended Max. Receive Error (%)
0	0	Default Baud Rate	Standard function	± 3%
0	1	Double Baud Rate	Standard function	± 3%
1	0	Double Baud Rate X2	Enhanced function	± 2%
1	1	Double Baud Rate X4	Enhanced function	± 1%

15.7.3. Baud Rate in Mode 1 & 3

Using Timer 1 as the Baud Rate Generator

$$\text{Mode 1, 3 Baud Rate} = \frac{2^{\text{SMOD1}} \times 2^{(\text{SMOD2} \times 2)}}{32} \times \frac{F_{\text{SYSCLK}}}{12 \times (256 - \text{TH1})} \quad ; \text{T1X12}=0 \\ \text{or} = \frac{2^{\text{SMOD1}} \times 2^{(\text{SMOD2} \times 2)}}{32} \times \frac{F_{\text{SYSCLK}}}{1 \times (256 - \text{TH1})} \quad ; \text{T1X12}=1$$

Note:

If SMOD2=0, T1X12=0, the baud rate formula is as same as standard 8051. If SMOD2=1, there is an enhanced function for baud rate setting. [Table 15–2](#) defines the Baud Rate setting with SMOD2 factor in Timer 1 baud rate generator.

Table 15–2. SMOD2 application criteria in Mode 1 & 3 using Timer 1

SMOD2	SMOD1	Baud Rate	Note	Recommended Max. Receive Error (%)
0	0	Default Baud Rate	Standard function	± 3%
0	1	Double Baud Rate	Standard function	± 3%
1	0	Double Baud Rate X2	Enhanced function	± 2%
1	1	Double Baud Rate X4	Enhanced function	± 1%

Table 15-3 ~ Table 15-10 list various commonly used baud rates and how they can be obtained from Timer 1 in its 8-Bit Auto-Reload Mode.

Table 15–3. Timer 1 Generated Commonly Used Baud Rates @ $F_{\text{SYSCLK}}=11.0592\text{MHz}$

Baud Rate	TH1, the Reload Value					
	T1X12=0 & SMOD2=0			T1X12=1 & SMOD2=0		
	SMOD1=0	SMOD1=1	Error	SMOD1=0	SMOD1=1	Error
1200	232	208	0.0%	--	--	--
2400	244	232	0.0%	112	--	0.0%
4800	250	244	0.0%	184	112	0.0%
9600	253	250	0.0%	220	184	0.0%
14400	254	252	0.0%	232	208	0.0%
19200	--	253	0.0%	238	220	0.0%
28800	255	254	0.0%	244	232	0.0%
38400	--	--	--	247	238	0.0%
57600	--	255	0.0%	250	244	0.0%
115200	--	--	--	253	250	0.0%
230400	--	--	--	--	253	0.0%

Table 15–4. Timer 1 Generated High Baud Rates @ $F_{\text{SYSCLK}}=11.0592\text{MHz}$

Baud Rate	TH1, the Reload Value					
	T1X12=0 & SMOD2=1			T1X12=1 & SMOD2=1		
	SMOD1=0	SMOD1=1	Error	SMOD1=0	SMOD1=1	Error
230.4K	--	255	0.0%	250	244	0.0%
460.8K	--	--	--	253	250	0.0%
691.2K	--	--	--	254	252	0.0%
921.6K	--	--	--	--	253	0.0%
1.3824M	--	--	--	255	254	0.0%
2.7648M	--	--	--	--	255	0.0%

Table 15–5. Timer 1 Generated Commonly Used Baud Rates @ $F_{\text{SYSCLK}}=22.1184\text{MHz}$

Baud Rate	TH1, the Reload Value					
	T1X12=0 & SMOD2=0			T1X12=1 & SMOD2=0		
	SMOD1=0	SMOD1=1	Error	SMOD1=0	SMOD1=1	Error
1200	208	160	0.0%	--	--	--
2400	232	208	0.0%	--	--	0.0%
4800	244	232	0.0%	112	--	0.0%
9600	250	244	0.0%	184	112	0.0%
14400	252	248	0.0%	208	160	0.0%
19200	253	250	0.0%	220	184	0.0%
28800	254	252	0.0%	232	208	0.0%
38400	--	253	0.0%	238	220	0.0%
57600	255	254	0.0%	244	232	0.0%
115200	--	255	0.0%	250	244	0.0%
230400	--	--	--	253	250	0.0%
460800	--	--	--	--	253	0.0%

Table 15–6. Timer 1 Generated High Baud Rates @ F_{sysclk}=22.1184MHz

Baud Rate	TH1, the Reload Value					
	T1X12=0 & SMOD2=1			T1X12=1 & SMOD2=1		
	SMOD1=0	SMOD1=1	Error	SMOD1=0	SMOD1=1	Error
460.8K	--	255	0.0%	250	244	0.0%
691.2K	--	--	--	252	248	0.0%
921.6K	--	--	--	253	250	0.0%
1.3824M	--	--	--	254	252	0.0%
1.8432M				--	253	0.0%
2.7648M	--	--	--	255	254	0.0%
5.5296M	--	--	--	--	255	0.0%

Table 15–7. Timer 1 Generated Commonly Used Baud Rates @ F_{sysclk}=12.0MHz

Baud Rate	TH1, the Reload Value					
	T1X12=0 & SMOD2=0			T1X12=1 & SMOD2=0		
	SMOD1=0	SMOD1=1	Error	SMOD1=0	SMOD1=1	Error
1200	230	204	0.16%	--	--	--
2400	243	230	0.16%	100	--	0.16%
4800	--	243	0.16%	178	100	0.16%
9600	--	--	--	217	178	0.16%
14400	--	--	--	230	204	0.16%
19200	--	--	--	--	217	0.16%
28800	--	--	--	243	230	0.16%
38400	--	--	--	246	236	2.34%
57600	--	--	--	--	243	0.16%
115200	--	--	--	--	--	--

Table 15–8. Timer 1 Generated High Baud Rates @ F_{sysclk}=12.0MHz

Baud Rate	TH1, the Reload Value					
	T1X12=0 & SMOD2=1			T1X12=1 & SMOD2=1		
	SMOD1=0	SMOD1=1	Error	SMOD1=0	SMOD1=1	Error
115.2K	--	--	--	243	230	0.16%
230.4K	--	--	--	--	243	0.16%
460.8K	--	--	--	--	--	--

Table 15–9. Timer 1 Generated Commonly Used Baud Rates @ F_{sysclk}=24.0MHz

Baud Rate	TH1, the Reload Value					
	T1X12=0 & SMOD2=0			T1X12=1 & SMOD2=0		
	SMOD1=0	SMOD1=1	Error	SMOD1=0	SMOD1=1	Error
1200	204	152	0.16%	--	--	--
2400	230	204	0.16%	--	--	--
4800	243	230	0.16%	100	--	0.16%
9600	--	243	0.16%	178	100	0.16%
14400	--	--	--	204	152	0.16%
19200	--	--	--	217	178	0.16%
28800	--	--	--	230	204	0.16%
38400	--	--	--	--	217	0.16%
57600	--	--	--	243	230	0.16%
115200	--	--	--	--	243	0.16%

Table 15–10. Timer 1 Generated High Baud Rates @ F_{sysclk}=24.0MHz

Baud Rate	TH1, the Reload Value					
	T1X12=0 & SMOD2=1			T1X12=1 & SMOD2=1		
	SMOD1=0	SMOD1=1	Error	SMOD1=0	SMOD1=1	Error
230.4K	--	--	--	243	230	0.16%
460.8K	--	--	--	--	243	0.16%
691.2K	--	--	--	--	--	--
921.6K	--	--	--	--	--	--

15.8. Serial Port Repeater Mode

Figure 15–10 shows the serial port repeater in MG86FE/L104. Software can configure the data flow path from RXD to TXD. It can select one of four RXD input into UART engine and directly route to 4 TXD outputs concurrently. The repeater function only supports serial port mode 1, 2 and 3.

Figure 15–10. Serial Port Repeater

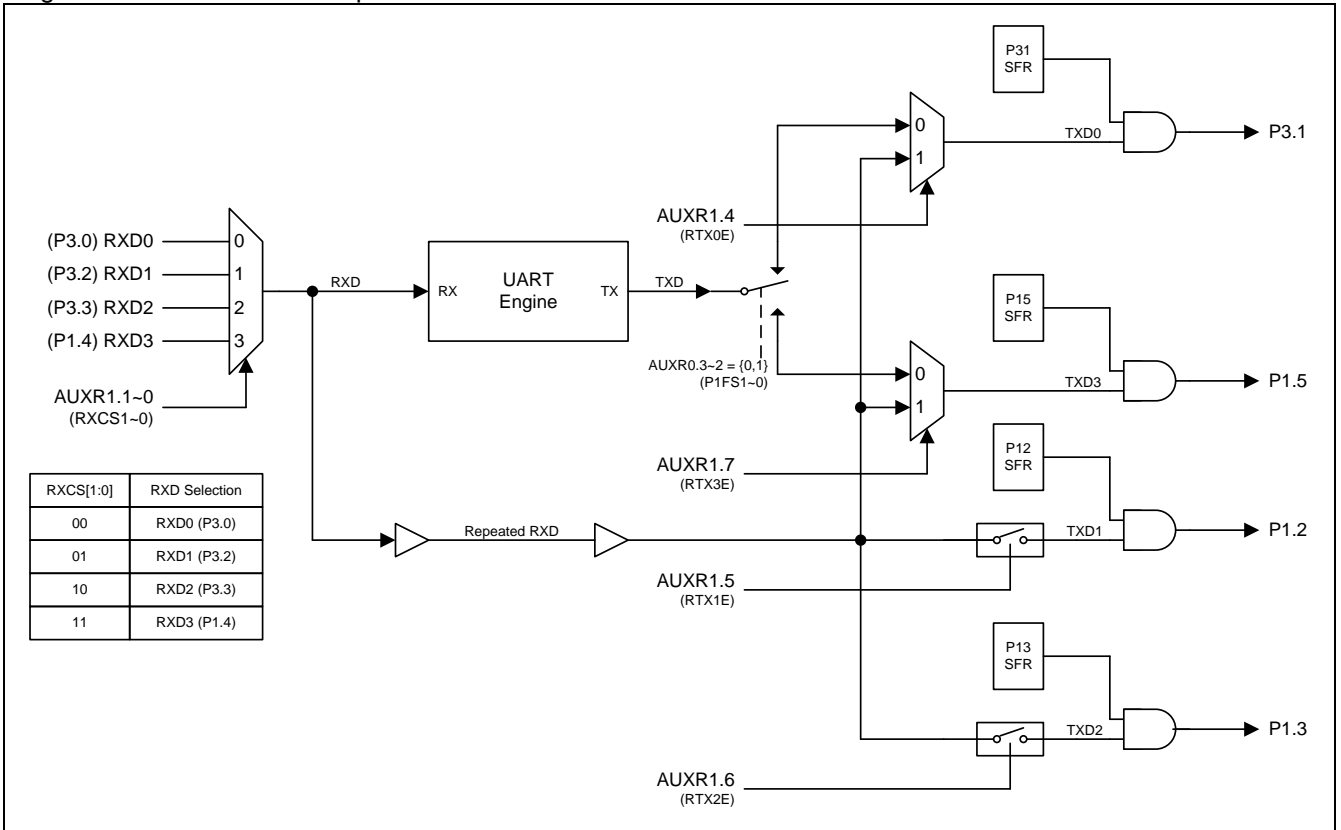

15.9. Serial Port Register

All the four operation modes of the serial port are the same as those of the standard 8051 except the baud rate setting. Three registers, PCON, AUXR and AUXR2, are related to the baud rate setting:

SCON: Serial port Control Register

SFR Page = Normal

SFR Address = 0x98

RESET = 0000-0000

7	6	5	4	3	2	1	0
SM0/FE	SM1	SM2	REN	TB8	RB8	TI	RI
R/W	R/W	R/W	R/W	R/W	R/W	R/W	R/W

Bit 7: FE, Framing Error bit. The SMOD0 bit must be set to enable access to the FE bit.

0: The FE bit is not cleared by valid frames but should be cleared by software.

1: This bit is set by the receiver when an invalid stop bit is detected.

Bit 7: Serial port mode bit 0, (SMOD0 must = 0 to access bit SM0)

Bit 6: Serial port mode bit 1.

SM0	SM1	Mode	Description	Baud Rate
0	0	0	shift register	SYSCLK/12 or /2
0	1	1	8-bit UART	variable
1	0	2	9-bit UART	SYSCLK/64, /32, /16 or /8
1	1	3	9-bit UART	variable

Bit 5: Serial port mode bit 2.

0: Disable SM2 function.

1: Enable the automatic address recognition feature in Modes 2 and 3. If SM2=1, RI will not be set unless the received 9th data bit is 1, indicating an address, and the received byte is a Given or Broadcast address. In mode1, if SM2=1 then RI will not be set unless a valid stop Bit was received, and the received byte is a Given or Broadcast address. In Mode 0, SM2 should be 0.

Bit 4: REN, Enable serial reception.

0: Clear by software to disable reception.

1: Set by software to enable reception.

Bit 3: TB8, The 9th data bit that will be transmitted in Modes 2 and 3. Set or clear by software as desired.

Bit 2: RB8, In Modes 2 and 3, the 9th data bit that was received. In Mode 1, if SM2 = 0, RB8 is the stop bit that was received. In Mode 0, RB8 is not used.

Bit 1: TI. Transmit interrupt flag.

0: Must be cleared by software.

1: Set by hardware at the end of the 8th bit time in Mode 0, or at the beginning of the stop bit in the other modes, in any serial transmission.

Bit 0: RI. Receive interrupt flag.

0: Must be cleared by software.

1: Set by hardware at the end of the 8th bit time in Mode 0, or halfway through the stop bit time in the other modes, in any serial reception (except see SM2).

SBUF: Serial Buffer Register

SFR Page = Normal

SFR Address = 0x99

RESET = XXXX-XXXX

7	6	5	4	3	2	1	0
SBUF.7	SBUF.6	SBUF.5	SBUF.4	SBUF.3	SBUF.2	SBUF.1	SBUF.0
R/W	R/W	R/W	R/W	R/W	R/W	R/W	R/W

Bit 7~0: It is used as the buffer register in transmission and reception.

SADDR: Slave Address Register

SFR Page = Normal

SFR Address = 0xA9

RESET = 0000-0000

7	6	5	4	3	2	1	0
R/W	R/W	R/W	R/W	R/W	R/W	R/W	R/W

SADEN: Slave Address Mask Register

SFR Page = Normal

SFR Address = 0xB9

RESET = 0000-0000

7	6	5	4	3	2	1	0
R/W	R/W	R/W	R/W	R/W	R/W	R/W	R/W

SADDR register is combined with SADEN register to form Given/Broadcast Address for automatic address recognition. In fact, SADEN functions as the “mask” register for SADDR register. The following is the example for it.

$$\begin{array}{rcl}
 \text{SADDR} & = & 1100\ 0000 \\
 \text{SADEN} & = & 1111\ 1101 \\
 \hline
 \text{Given} & = & 1100\ 00x0 \longrightarrow \text{The Given slave address will be checked except} \\
 & & \text{bit 1 is treated as “don't care”}
 \end{array}$$

The Broadcast Address for each slave is created by taking the logical OR of SADDR and SADEN. Zero in this result is considered as “don't care”. Upon reset, SADDR and SADEN are loaded with all 0s. This produces a Given Address of all “don't care” and a Broadcast Address of all “don't care”. This disables the automatic address detection feature.

PCON0: Power Control Register 0

SFR Page = Normal & Page P

SFR Address = 0x87

POR = 00X1-0000, RESET = 00X0-0000

7	6	5	4	3	2	1	0
SMOD1	SMOD0	GF	POF	GF1	GF0	PD	IDL
R/W	R/W	R/W	R/W	R/W	R/W	R/W	R/W

Bit 7: SMOD1, double Baud rate control bit.

0: Disable double Baud rate of the UART.

1: Enable double Baud rate of the UART in mode 1, 2, or 3.

Bit 6: SMOD0, Frame Error select.

0: SCON.7 is SM0 function.

1: SCON.7 is FE function. Note that FE will be set after a frame error regardless of the state of SMOD0.

AUXR1: Auxiliary Register 1

SFR Page = Normal

SFR Address = 0xA2

RESET = 0000-0000

7	6	5	4	3	2	1	0
RTX3E	RTX2E	RTX1E	RTX0E	--	--	RXCS1	RXCS0
R/W	R/W	R/W	R/W	W	W	R/W	R/W

Bit 7: RTX3E, RXD Repeat to TXD3 enabled.

0: Disable RTX3E function on TXD3 (P1.5).

1: Enable the RXD repeat mechanism on TXD3 (P1.5).

Bit 6: RTX2E, RXD Repeat to TXD2 enabled.

0: Disable RTX2E function on TXD2 (P1.3).

1: Enable the RXD repeat mechanism on TXD3 (P1.3).

Bit 5: RTX1E, RXD Repeat to TXD1 enabled.

0: Disable RTX1E function on TXD1 (P1.2).

1: Enable the RXD repeat mechanism on TXD1 (P1.2).

Bit 4: RTX0E, RXD Repeat to TXD0 enabled.

0: Disable RTX0E function on TXD0 (P3.1).

1: Enable the RXD repeat mechanism on TXD0 (P3.1).

Bit 3~2: Reserved. Software must write "0" on these bits when AUXR1 is written.

Bit 1~0: RXD channel selection.

RXCS[1:0]	RXD channel selection
00	P3.0
01	P3.2
10	P3.3
11	P1.4

AUXR2: Auxiliary Register 2

SFR Page = Normal

SFR Address = 0xA3

RESET = 0000-0000

7	6	5	4	3	2	1	0
URXR	BTI	URM0X6	SMOD2	T1X12	T0X12	T1CKOE	T0CKOE
R/W	R/W	R/W	R/W	R/W	R/W	R/W	R/W

Bit 7: URXR, Serial Port test mode. Software must write "0" on this bit when AUXR2 is written.

Bit 6: BTI, Block TI in Serial Port Interrupt.

0: Retain the TI to be a source of Serial Port Interrupt.

1: Block TI to be a source of Serial Port Interrupt.

Bit 5: URM0X6, Serial Port mode 0 baud rate selector.

0: Clear to select SYSCLK/12 as the baud rate for UART Mode 0.

1: Set to select SYSCLK/2 as the baud rate for UART Mode 0.

Bit 4: SMOD2, extra X2/X4 baud rate selector.

0: Disable extra X2/X4 baud rate.

1: Enable extra X2/X4 baud rate.

Bit 3: T1X12, Timer 1 clock source selector while C/T=0.

0: Clear to select SYSCLK/12.

1: Set to select SYSCLK as the clock source.

SFIE: System Flag Interrupt Enable Register

SFR Page = Normal

SFR Address = 0x8E

RESET = 0xxx-0x00

7	6	5	4	3	2	1	0
UTIE	--	--	--	KBIFIE	--	BOF0IE	WDTFIE
R/W	W	W	W	R/W	W	R/W	R/W

Bit 7: UTIE, UART TI Enabled in system flag interrupt.

0: Disable the interrupt vector sharing for TI in system flag interrupt.

1: Set TI flag will share the interrupt vector with system flag interrupt.

15.10. Serial Port Sample Code

(1). Required Function: IDLE mode with RI wake-up capability

Assembly Code Example:	
<pre> ORG 00023h uart_ri_idle_isr: JB RI,RI_ISR ; JB TI,TI_ISR ; RETI ; RI_ISR: ; Process CLR RI ; RETI ; TI_ISR: ; Process CLR TI ; RETI ; main: CLR TI ; CLR RI ; SETB SM1 ; SETB REN ; 8bit Mode2, Receive Enable MOV IP0L,#PSL ; Select S0 interrupt priority MOV IP0H,#PSH ; SETB ES ; Enable S0 interrupt SETB EA ; Enable global interrupt ORL PCON0,#IDL; ; Set MCU into IDLE mode</pre>	
C Code Example:	
<pre>void uart_ri_idle_isr(void) interrupt 4 { if(RI) { RI=0; // to do ... } if(TI) { TI=0; // to do ... } } void main(void) { TI = RI = 0; SM1 = REN = 1; // 8bit Mode2, Receive Enable IP0L = PSL; // Select S0 interrupt priority IP0H = PSH; // ES = 1; // Enable S0 interrupt EA = 1; // Enable global interrupt PCON = IDL; // Set MCU into IDLE mode }</pre>	

16. Keypad Interrupt (KBI)

The Keypad Interrupt function is intended primarily to allow a single interrupt to be generated when enabled port pin is a falling edge occurred. This function can be used keypad recognition. Figure 16–1 shows the structure of the keypad interrupt function.

There are two SFRs used for this function. Each bit in P1KBIE and P3KBIE controls the associated port pin to enable or disable the KBI function at falling edge occurred. Any recognized KBI event will cause the hardware to set the interrupt flag KBIF and generate an interrupt if it has been enabled. Not necessary to enable the KBI interrupt, enabled KBI port pin can wakeup CPU from idle mode (falling edge) and power-down mode (low level).

16.1. Keypad Interrupt Structure

Figure 16–1. Keypad Interrupt Structure

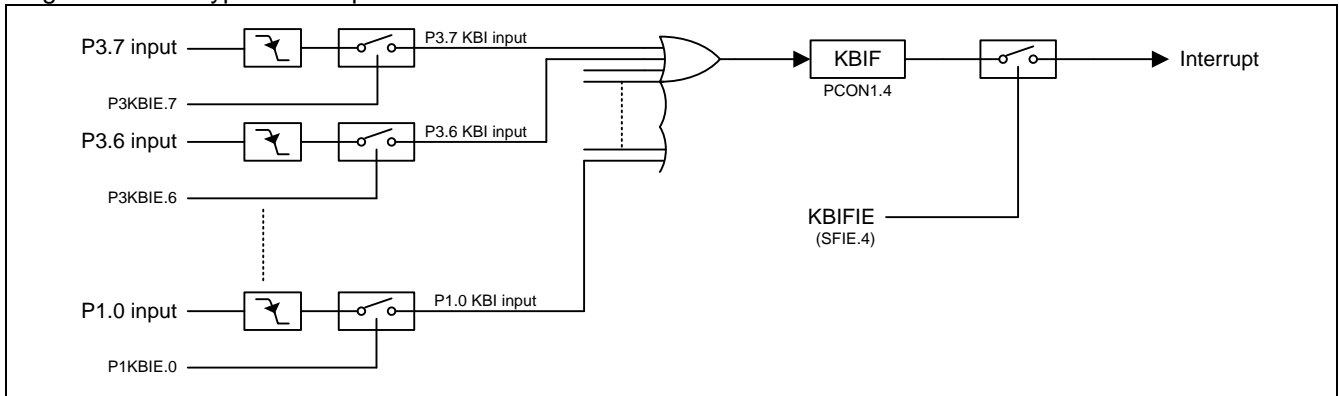

16.2. Keypad Interrupt Register

P1KBIE: Port 1 KBI Enable Control Register

SFR Page = Normal

SFR Address = 0xD7

RESET = 0000-0000

7	6	5	4	3	2	1	0
P17KBIE	P16KBIE	P15KBIE	P14KBIE	P13KBIE	P12KBIE	P11KBIE	P10KBIE
R/W	R/W	R/W	R/W	R/W	R/W	R/W	R/W

Bit 7~0: Keypad Input function enable bit for each Port 1 pins.

0: Disable associated port pin for keypad input function.

1: Enable associated port pin for keypad input function.

P3KBIE: Port 3 KBI Enable Control Register

SFR Page = Normal

SFR Address = 0xD6

RESET = 0000-0000

7	6	5	4	3	2	1	0
P37KBIE	P36KBIE	P35KBIE	P34KBIE	P41KBIE	P40KBIE	P31KBIE	P30KBIE
R/W	R/W	R/W	R/W	R/W	R/W	R/W	R/W

Bit 7~0: Keypad Input function enable bit for P3.7 ~ P3.4, P4.1, P4.0, P3.1 and P3.0 pins.

0: Disable associated port pin for keypad input function.

1: Enable associated port pin for keypad input function.

PCON1: Power Control Register 1

SFR Page = Normal & Page P

SFR Address = 0x97

POR = 0010-0X00

7	6	5	4	3	2	1	0
SWRF	EXRF	--	--	KBIF	--	BOF0	WDTF
R/W	R/W	W	W	R/W	W	R/W	R/W

Bit 3: KBIF, Keypad Interrupt Flag.

0: This bit must be cleared by software writing "1" on it. Software writing ":0" is no operation.

1: This bit is only set by falling edge on enabled KBI port pin. Writing "1" on this bit will clear KBIF. In power down mode, this bit is set by low level on enabled KBI port pin.

16.3. Keypad Interrupt Sample Code

(1). Required Function: Implement a KBI function on P1.3~P1.0

Assembly Code Example:	
ORG	0003Bh
SystemFlag_ISR:	;
PUSH	ACC
	;
MOV	A,PCON1
	;
JNB	ACC.3,Not_KBIF_ISR
	;
To do.....	
ANL	PCON1,#KBIF ; Clear KBI flag (write "1")
Not_KBIF_ISR:	
POP	ACC
	;
RETI	;
main:	
ORL	PUCON0,#PU10 ; Enable P1.3~P1.0 on-chip pull-up resistor
ANL	P1M0,#0F0h ; Set P1.3~P1.0 to Open-Drain Output
ORL	P1,#00Fh ; Set P1.3~P1.0 to Input mode
ORL	EIP1L,#PSFL ; Select SystemFlag interrupt priority
ORL	EIP1H,#PSFH ;
MOV	P1KBIE,#00Fh ; Enable P1.3~P1.0 KBI function
;	MOV P3KBIE,#0xF3 ; Enable P3 KBI function
;	MOV P3KBIE,#0x0C ; Enable P4.1~0 KBI function
ANL	PCON1,#KBIF ; Clear KBI flag (write "1")
ORL	SFIE,#KBIFIE ; Enable KBI interrupt
ORL	EIE1,#ESF ; Enable SystemFlag interrupt
SETB	EA ; Enable global interrupt
ORL	PCON0,#PD ; Set MCU into power-down mode
C Code Example:	
void SystemFlag_ISR(void) interrupt 7	
{	if(PCON1 & KBIF)
{	PCON1 &= KBIF; // Clear KBI Flag
}	
}	
void main(void)	
{	
PUCON0 = PU10;	// Enable P1.3~P1.0 on-chip pull-up resistor
P1M0 &= 0xF0;	// Set P1.3~P1.0 to Open-Drain Output
P1 = 0x0F;	// Set P1.3~P1.0 to Input mode
EIP1L = PSFL;	// Select SystemFlag interrupt priority
EIP1H = PSFH;	
P1KBIE = 0x0F;	// Enable P1.3~P1.0 KBI function
// P3KBIE = 0xF3;	// Enable P3 KBI function
// P3KBIE = 0x0C;	// Enable P4.1~0 KBI function
PCON1&= KBIF;	// Clear KBI flag (write "1")
SFIE = KBIFIE;	// Enable KBI interrupt
EIE1 = ESF;	// Enable SystemFlag interrupt
EA = 1;	// Enable global interrupt
PCON0 = PD;	// Set MCU into power-down mode
}	

17. ISP and IAP

17.1. Flash Memory Configuration

There are total 4K bytes of Flash Memory in **MG86FE/L104** and **Figure 17–1** shows the device flash configuration. The flash can be partitioned into AP-memory, IAP-memory and ISP-memory. AP-memory is used to store user's application program; IAP-memory is used to store the non-volatile application data; and, ISP-memory is used to store the boot loader program for In-System Programming. When MCU is running in ISP region, MCU could modify the AP and IAP memory for software upgraded. If MCU is running in AP region, MCU could only modify the IAP memory for storage data updated.

Figure 17–1. Flash Memory Configuration

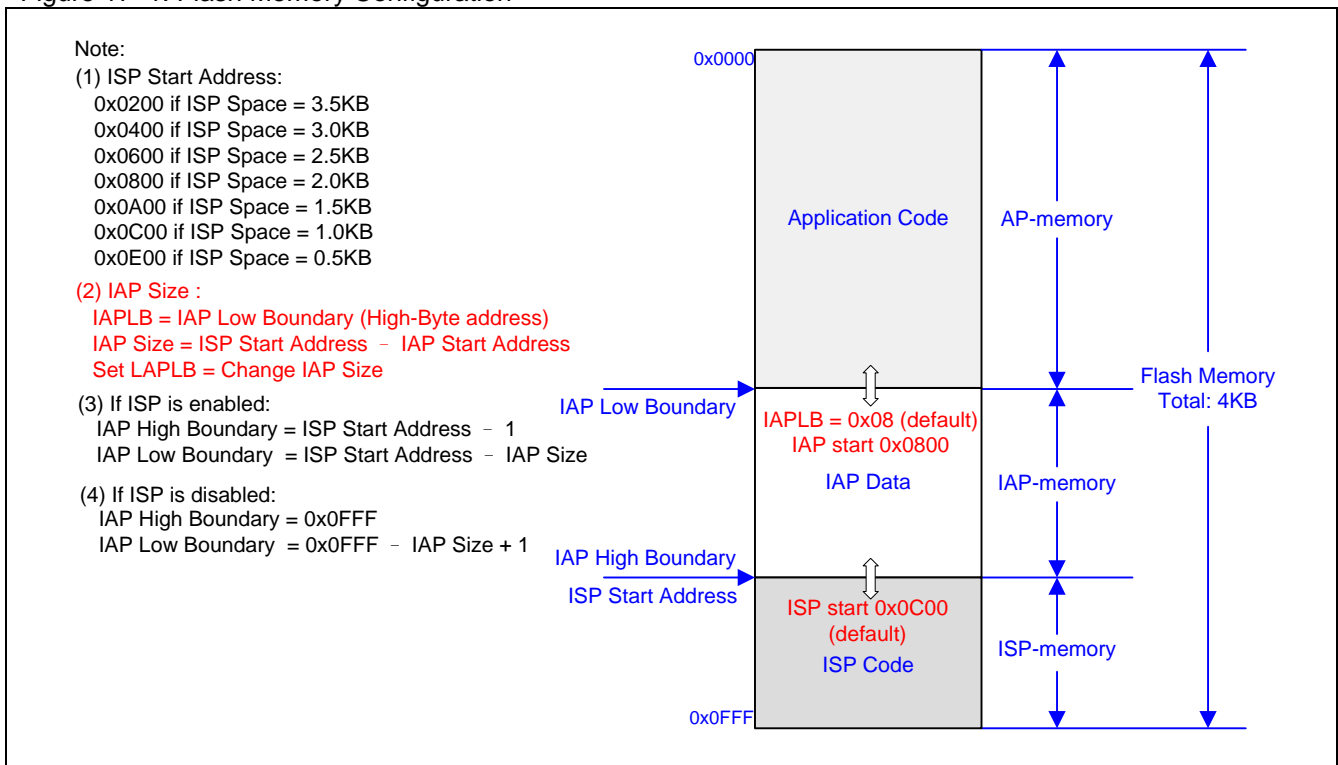

Note:

In default, the samples that Megawin shipped had configured the flash memory for 1K ISP, 1K IAP and Lock enabled. The 1K ISP region is inserted Megawin proprietary ISP code to perform In-System-Programming through Megawin 1-Line ISP protocol.

MG86FE/L104 does not make use of idle-mode to perform ISP and IAP function. Instead, it freezes CPU running to release the flash memory for ISP or IAP engine operating. Once ISP/IAP operation finished, CPU will be resumed and advanced to the instruction which follows the previous instruction that invokes ISP/AP activity. During ISPIAP operation, interrupt service is also blocked until ISP/IAP finished.

17.2. In-System-Programming (ISP)

The flash memory of **MG86FE/L104** can be both programming by the universal Writer/Programmer or the way of In-System Programming (ISP). ISP makes it possible to update the user's application program (in AP-memory) and non-volatile application data (in IAP-memory) without removing the MCU chip from the actual end product. This useful capability makes a wide range of field-update applications possible.

Note:

- (1) Before using the ISP feature, the user should configure an ISP-memory space and pre-program the ISP code into the ISP-memory by a universal Writer/Programmer or Megawin proprietary Writer/Programmer.
- (2) ISP code in the ISP-memory can only program the AP-memory and IAP-memory.

17.2.1. ISP/IAP Register

The following special function registers are related to the access of ISP, IAP and Page-P SFR:

IFD: ISP/IAP Flash Data Register

SFR Page = Normal

SFR Address = 0xE2 RESET = 1111-1111

7	6	5	4	3	2	1	0
R/W	R/W	R/W	R/W	R/W	R/W	R/W	R/W

IFD is the data port register for ISP/IAP/Page-P operation. The data in IFD will be written into the desired address in operating ISP/IAP/Page-P write and it is the data window of readout in operating ISP/IAP read.

IFADRH: ISP/IAP Address for High-byte addressing

SFR Page = Normal

SFR Address = 0xE3 RESET = 0000-0000

7	6	5	4	3	2	1	0
R/W	R/W	R/W	R/W	R/W	R/W	R/W	R/W

IFADRH is the high-byte address port for all ISP/IAP modes.

IFADRL: ISP/IAP Address for Low-byte addressing

SFR Page = Normal

SFR Address = 0xE4 RESET = 0000-0000

7	6	5	4	3	2	1	0
R/W	R/W	R/W	R/W	R/W	R/W	R/W	R/W

IFADRL is the low byte address port for all ISP/IAP/Page-P modes.

IFMT: ISP/IAP Flash Mode Table

SFR Page = Normal

SFR Address = 0xE5 RESET = xxxx-x000

7	6	5	4	3	2	1	0
--	--	--	--	--	MS.2	MS.1	MS.0
W	W	W	W	W	R/W	R/W	R/W

Bit 7~4: Reserved. Software must write "0000_0" on these bits when IFMT is written.

Bit 3~0: ISP/IAP/Page-P operating mode selection

MS[2:0]	Mode
0 0 0	Standby
0 0 1	Flash byte read of AP/IAP-memory
0 1 0	Flash byte program of AP/IAP-memory
0 1 1	Reserved
1 0 0	Page P SFR Write
Others	Reserved

IFMT is used to select the flash mode for performing numerous ISP/IAP function or to select page P SFR access.

IAPLB: IAP Low Boundary

SFR Page = Page P Only

SFR Address = 0x03

RESET = 1111-111x

7	6	5	4	3	2	1	0
IAPLB							0
W	W	W	W	W	W	W	W

Bit 7~0: The IAPLB determines the IAP-memory lower boundary. Since a Flash page has 512 bytes, the IAPLB must be an even number.

To read IAPLB, MCU need to define the IMFT for mode selection on IAPLB Read and set ISPCR.ISPEN. And then write 0x46h & 0xB9h sequentially into SCMD. The IAPLB content is available in IFD. If write IAPLB, MCU will put new IAPLB setting value in IFD firstly. And then select IMFT, enable ISPCR.ISPEN and then set SCMD. The IAPLB content has already finished the updated sequence.

The range of the IAP-memory is determined by IAPLB and the ISP start address as listed below.

IAP lower boundary = IAPLBx256, and

IAP higher boundary = ISP start address - 1.

For example, if IAPLB=0x08 and ISP start address is 0x0C00, then the IAP-memory range is located at 0x0800 ~ 0x0BFF.

Additional attention point, the IAP low boundary address must not be higher than ISP start address.

SCMD: Sequential Command Data register

SFR Page = Normal

SFR Address = 0xE6

RESET = xxxx-xxxx

7	6	5	4	3	2	1	0
SCMD							
R/W	R/W	R/W	R/W	R/W	R/W	R/W	R/W

SCMD is the command port for triggering ISP/IAP/Page-P activity. If SCMD is filled with sequential 0x46h, 0xB9h and if ISPCR.7 = 1, ISP/IAP/Page-P activity will be triggered.

ISPCR: ISP Control Register

SFR Page = Normal

SFR Address = 0xE7

RESET = 0000-0xxx

7	6	5	4	3	2	1	0
ISPEN	SWBS	SWRST	CFAIL	--	--	--	--
R/W	R/W	R/W	R/W	W	W	W	W

Bit 7: ISPEN, ISP/IAP/Page-P operation enable.

0: Global disable all ISP/IAP/Page-P program/ read function.

1: Enable ISP/IAP/Page-P program/ read function.

Bit 6: SWBS, software boot selection control.

0: Boot from main-memory after reset.

1: Boot from ISP memory after reset.

Bit 5: SWRST, software reset trigger control.

0: No operation

1: Generate software system reset. It will be cleared by hardware automatically.

Bit 4: CFAIL, Command Fail indication for ISP/IAP operation.

0: The last ISP/IAP command has finished successfully.

1: The last ISP/IAP command fails. It could be caused since the access of flash memory was inhibited.

Bit 3~0: Reserved. Software must write "0" on these bits when ISPCR is written.

17.2.2. Description for ISP Operation

CPU in **MG86FE/L104** can be vectored into ISP-memory space from two possible ways: When HWBS (in hardware option bits) enabled, **MG86FE/L104** will always boot from the ISP-memory on the specified "ISP start address" since power-on. This way is named as hardware approach. Another way is software approach that allows **MG86FE/L104** execution switched into ISP-memory from AP memory by software setting ISPCR.7 ~ ISPCR.5 to "111" simultaneously.

Once CPU in ISP memory region and ISPEN = 1, accurate values in ISP-related registers should be confirmed by ISP software. Then, sequentially writing 0x46h, 0xB9h into SCMD are used to really trigger memory access operations (flash byte programming and flash byte read).

After ISP operation has been finished, software writes "001" on ISPCR.7 ~ ISPCR.5 which triggers an software RESET and makes CPU reboot into application program memory (AP-memory) on the address 0x0000.

To do Byte Program

Step 1: Set MS[2:0]=[0,1,0] in ISPCR register to select Byte Program Mode.

Step 2: Fill byte address in IFADRH & IFADRL registers.

Step 3: Fill data to be programmed in IFD register.

Step 4: Sequentially write 0x46h then 0xB9h to SCMD register to trigger an ISP processing.

To do Read

Step 1: Set MS[2:0]=[0,0,1] in ISPCR register to select Read Mode.

Step 2: Fill byte address in IFADRH & IFADRL registers.

Step 3: Sequentially write 0x46h then 0xB9h to SCMD register to trigger an ISP processing.

Step 4: Now, the Flash data is in IFD register.

17.2.3. Sample Code for ISP

Figure 17–2. shows a sample code for ISP operation.

Figure 17–2. Sample Code for ISP

```
*****
; Demo Program for the ISP
*****
IFD      DATA    0E2h
IFADRH   DATA    0E3h
IFADRL   DATA    0E4h
IFMT     DATA    0E5h
SCMD     DATA    0E6h
ISPCR    DATA    0E7h
;
;           MOV     ISPCR,#10000000b ;ISPCR.7=1, enable ISP
;
;=====
; 1. Byte Program Mode
;=====
;           ORL     IFMT,#02h      ;MS[2:0]=[0,1,0], select Byte Program Mode
;           ANL     ISPCR,#0FAh   ;
;           MOV     IFADRH,??     ;fill byte address in IFADRH & IFADRL
;           MOV     IFADRL,??     ;
;           MOV     IFD,??        ;fill the data to be programmed in IFD
;           MOV     SCMD,#46h     ;trigger ISP processing
;           MOV     SCMD,#0B9h    ;
;           ;Now in processing...(CPU will halt here until complete)
;
;=====
; 2. Verify using Read Mode
;=====
;           ANL     IFMT,#0F9h    ;MS1[2:0]=[0,0,1], select Byte Read Mode
;           ORL     IFMT,#01h     ;
;           MOV     IFADRH,??     ;fill byte address in IFADRH & IFADRL
;           MOV     IFADRL,??     ;
;           MOV     SCMD,#46h     ;trigger ISP processing
;           MOV     SCMD,#0B9h    ;
;           ;Now in processing...(CPU will halt here until complete)
;           MOV     A,IFD         ;data will be in IFD
;           CJNE   A,wanted,ISP_error ;compare with the wanted value
;           ...
ISP_error:
;           ...
;
```

17.3. In-Application-Programming (IAP)

The device is *In Application Programmable* (IAP), which allows some region in the Flash memory to be used as non-volatile data storage while the application program is running. This useful feature can be applied to the application where the data must be kept after power off. Thus, there is no need to use an external serial EEPROM (such as 93C46, 24C01, ..., and so on) for saving the non-volatile data.

In fact, the operating of IAP is the same as that of ISP except the Flash range to be programmed is different. The programmable Flash range for ISP operating is located within the AP and IAP memory, while the range for IAP operating is only located within the configured IAP-memory.

Note:

- (1) Before using the IAP feature, the software should specify an IAP-memory space by writing IAPLB in Page-P SFR. The IAP-memory space can be also configured by a universal Writer/Programmer or Megawin proprietary Writer/Programmer which configuration is corresponding to IAPLB initial value.
- (2) The program code to execute IAP is located in the AP-memory and **just only** program IAP-memory **not** ISP-memory.

17.3.1. IAP-memory Boundary/Range

If ISP-memory is specified, the range of the IAP-memory is determined by IAP and the ISP starts address as listed below.

$$\begin{aligned} \text{IAP high boundary} &= \text{ISP start address} - 1. \\ \text{IAP low boundary} &= \text{ISP start address} - \text{IAP}. \end{aligned}$$

If ISP-memory is not specified, the range of the IAP-memory is determined by the following formula.

$$\begin{aligned} \text{IAP high boundary} &= 0x0FFF. \\ \text{IAP low boundary} &= 0x0FFF - \text{IAP} + 1. \end{aligned}$$

For example, if ISP-memory is 1K, so that ISP start address is 0x0C00, and IAP-memory is 1K, then the IAP-memory range is located at 0x0800 ~ 0x0BFF. The IAP low boundary in **MG86FE/L104** is defined by IAPLB register which can be modified by software to adjust the IAP size in user's AP program.

17.3.2. Update data in IAP-memory

The special function registers are related to ISP/IAP would be shown in Section "[17.2.1 ISP/IAP Register](#)".

Except whole chip erase operation, **MG86FE/L104** has no flash erasing operation before any flash byte program. To update "one byte" in the IAP-memory, users can directly program the new datum into the target byte. The following steps show the proper procedure:

Step 1: Program the updated data into target addressing memory. (*using Byte Program mode of ISP*).

Step 2: To read the data in the IAP-memory for verification, users can use either the "*MOVC A,@A+DPTR*" instruction or the *Read mode of ISP*.

17.4.ISP/IAP Sample Code

(1). Required Function: General function call for ISP/IAP flash read

Assembly Code Example:	
_ixp_read:	
ixp_read:	
MOV	ISPCR,#ISPEN ; Enable Function
MOV	IFMT,#MS0 ; ixp_read=0x01
MOV	SCMD,#046h ;
MOV	SCMD,#0B9h ;
MOV	IFMT,#000h ; Flash_Standby=0x00
ANL	ISPCR,#~ISPEN ; Disable Function
RET	
C Code Example:	
void ixp_read (void)	
{	
ISPCR = ISPEN;	// Enable Function
IFMT = IxP_Flash_Read;	// IxP_Read=0x01
SCMD = 0x46;	//
SCMD = 0xB9;	//
IFMT = Flash_Standby;	// Flash_Standby=0x00
ISPCR &= ~ISPEN;	
}	

(2). Required Function: General function call for ISP/IAP flash program

Assembly Code Example:	
_ixp_program:	
ixp_program:	
PUSH	ACC ;
PUSH	IFADRH ;
PUSH	IFADRL ;
PUSH	IFD ;
MOV	IFADRL,#WDTCR ;
MOV	IFD,WDTCR ;
ORL	IFD,#CLRW ;
CALL	page_p_sfr_write ;
POP	IFD ;
POP	IFADRL ;
POP	IFADRH ;
MOV	ISPCR,#ISPEN ; Enable Function
MOV	IFMT,#MS1 ; IxP_Write=0x02
MOV	SCMD,#046h ;
MOV	SCMD,#0B9h ;
PUSH	IFD ;
MOV	A,IFD ;
CPL	A ;
MOV	IFD,A ;
MOV	IFMT,#MS0 ; IxP_Read=0x01
MOV	SCMD,#046h ;

```

MOV    SCMD,#0B9h          ;
;    if(reg[2] == IFD)
POP    ACC                  ;
CJNE   A,IFD,ixp_first_progma_fail ;
JMP    ixp_progma_Pass     ;

ixp_first_progma_fail:
;    page_p_sfr_write (WDTCR_P,(WDTCR | CLRW)); //
MOV    IFD,A                ;
PUSH   IFADRH               ;
PUSH   IFADRL               ;
PUSH   IFD                  ;

MOV    IFADRL,#WDTCR        ;
MOV    IFD,WDTCR            ;
ORL    IFD,#CLRW            ;
CALL   page_p_sfr_write     ;

POP    IFD                  ;
POP    IFADRL               ;
POP    IFADRH               ;

ANL    ISPCR,#~CFAIL        ;
MOV    IFMT,#MS1            ; ixp_write=0x02
MOV    SCMD,#046h           ;
MOV    SCMD,#0B9h           ;

PUSH   IFD                  ;
MOV    A,IFD                ;
CPL    A                    ;
MOV    IFD,A                ;

MOV    IFMT,#MS0            ; IxP_Read=0x01
MOV    SCMD,#046h           ;
MOV    SCMD,#0B9h           ;

;    if(reg[2] == IFD)
POP    ACC                  ;
CJNE   A,IFD,ixp_second_progma_Fail ;
ixp_progma_Pass:
;    SETB    ixp_program_state      ; Pass equ 1
;    CLR     ixp_program_state      ; Pass equ 0

end_ixp_program:
MOV    IFMT,#000h          ;
ANL    ISPCR,#~ISPEN       ;

POP    ACC                  ;
RET                                ;

ixp_second_progma_Fail:
;    CLR     ixp_program_state      ; Fail equ 0
;    SETB    ixp_program_state      ; Fail equ 1
JMP    end_ixp_program     ;

```

C Code Example:

```

bit ixp_program(void)
{
    unsigned char reg[3];

    reg[0] = IFADRH;          //
    reg[1] = IFADRL;          //
    reg[2] = IFD;

    IFADRL = WDTCR_P;        //
    IFD = (WDTCR | CLRW);    //
    page_p_sfr_write ();    //
}

```

```

IFADRH = reg[0];           //
IFADRL = reg[1];         //
IFD = reg[2];            //

ISPCR = ISPEN;           // Enable Function
IFMT = IxP_Flash_Program; // IxP_Write=0x02

SCMD = 0x46;
SCMD = 0xB9;

IFD = ~reg[2];          //

IFMT = IxP_Flash_Read;  // IxP_Read=0x01
SCMD = 0x46;           //
SCMD = 0xB9;           //

if(reg[2] == IFD)       //
{
    IFMT = Flash_Standby; // Flash_Standby=0x00
    ISPCR &= ~ISPEN;      //
    return(Pass);        //
}
else                    //
{
    IFADRL = WDTCR_P;    //
    IFD = (WDTCR | CLRW); //
    page_p_sfr_write (); //

    IFADRH = reg[0];    //
    IFADRL = reg[1];    //
    IFD = reg[2];       //

    ISPCR &= ~CFAIL;    //
    IFMT = IxP_Flash_Program; //IxP_Write=0x02

    SCMD = 0x46;        //
    SCMD = 0xB9;        //

    IFD = ~reg[2];      //

    IFMT = IxP_Flash_Read; //IxP_Read=0x01
    SCMD = 0x46;        //
    SCMD = 0xB9;        //

    IFMT = Flash_Standby; //Flash_Standby=0x00
    ISPCR &= ~ISPEN;    //

    if(reg[2] != IFD)   //
    {
        return(Fail);  //
    }
    else                //
    {
        return(Pass);  //
    }
}
}
}

```

(3). Required Function: ISP Sample code with CFAIL Checked and CLR WDT by hardware approached mode, Write twice if CFAIL true.

Assembly Code Example:	
isp_hw_approached:	
MOV DPH,#High(00000h)	;
MOV DPL,#LOW(00000h)	;
isp_hw_write_loop:	
MOV IFADRL,DPL	;
MOV IFADRH,DPH	;
MOV IFD,#055h	; ISP Program Data
CALL ixp_program	;
; JNB ixp_program_state,isp_hw_write_fail	; Fail EQU 0
JB ixp_program_state,isp_hw_write_fail	; Fail EQU 1
isp_hw_write_next:	
INC DPTR	;
MOV A,DPH	;
CJNE A,#01Ch,isp_hw_write_loop	;
ANL ISPCR,#~SWBS	;
ORL ISPCR,#SWRST	;
isp_hw_write_fail:	
; to do ...	
JMP isp_hw_write_next	;
C Code Example:	
unsigned short addr=0x0000;	//
do{ IFADRH = (unsigned char)(addr >>8);	
IFADRL = (unsigned char)addr ;	//
IFD = 0x55;	//
if(ixp_program() == Fail);	//
{	
// to do ...	
}	
}while(++addr != 0x1C00);	//
ISPCR = SWRST;	// Select AP Boot & SoftWave Reset

(4). Required Function: ISP Sample code by Software approached entrance

Assembly Code Example:	
MOV ISPCR,#(SWBS SWRST)	;
C Code Example:	
ISPCR = (SWBS SWRST) ;	//

(5). Required Function: IAPLB Change to on-chip flash 4K boundary

Assembly Code Example:

```
MOV    IFADRL,#IAPLB          ;
MOV    IFD,#(HIGH(4096))&0xFE ;
CALL   page_p_sfr_write      ;
```

C Code Example:

```
IFADRL = IAPLB; //
IFD = (((unsigned char)(4096 >> 8)) & 0xFE); //
page_p_sfr_write(); //
```

18. Page P SFR Access

MG86FE/L104 builds a special SFR page (Page P) to store the control registers for MCU operation. These SFRs can be accessed by the ISP/IAP operation with different IFMT. In page P access, IFADRH must set to “00” and IFADRL indexes the SFR address in page P. If IFMT= 04H for Page P writing, the content in IFD will be loaded to the SFR in IFADRL indexed after the SCMD triggered. The SFRs in Page-P don't support read function.

Following descriptions are the SFR function definition in Page P:

IAPLB: IAP Low Boundary

SFR Page = Page P Only

SFR Address = 0x03

RESET = 1111-1111

7	6	5	4	3	2	1	0
IAPLB							0
W	W	W	W	W	W	W	W

Bit 7~0: The IAPLB determines the IAP-memory lower boundary.

To write IAPLB, MCU will put new IAPLB setting value in IFD firstly. And index IFADRL, select IMFT, enable ISPCR.ISPEN and then set SCMD. The IAPLB content has already finished the updated sequence.

The range of the IAP-memory is determined by IAPLB and the ISP Start address as listed below.

IAP lower boundary = IAPLBx256, and

IAP higher boundary = ISP start address – 1.

For example, if IAPLB=0x08 and ISP start address is 0x0C00, then the IAP-memory range is located at 0x0800 ~ 0x0BFF.

Additional attention point, the IAP low boundary address must not be higher than ISP start address.

CKCON2: Clock Control Register 2

SFR Page = Page P Only

SFR Address = 0x40

RESET = 0001-xx00

7	6	5	4	3	2	1	0
--	--	XTALE	IHRCOE	--	--	OSCS1	OSCS0
W	W	W	W	W	W	W	W

Bit 7~6: Reserved. Software must write “0” on this bit when CKCON2 is written.

Bit 5: XTALE, external Crystal(XTAL) Enable. The default value is set by hardware option on clock source selection.

0: Disable XTAL oscillating circuit. In this case, XTAL2 and XTAL1 behave as Port 6.0 and Port 6.1.

1: Enable XTAL oscillating circuit. If this bit is set by CPU software, it needs **3 ms** to have stable output after XTALE is enabled.

Bit 4: IHRCOE, Internal High frequency RC Oscillator Enable. The default value is set by hardware option on clock source selection.

0: Disable internal high frequency RC oscillator.

1: Enable internal high frequency RC oscillator. If this bit is set by CPU software, it needs **32 us** to have stable output after IHRCOE enabled.

Bit 3~2: Reserved. Software must write “0” on these bits when CKCON2 is written.

Bit 1~0: OSC[1:0], OSCin source selection.

OSCS[1:0]		OSCin source Selection
0	0	IHRCO
0	1	XTAL
1	0	ILRCO
1	1	ECKI, External Clock Input (P4.0) as OSCin.

PCON2: Power Control Register 2

SFR Page = Page P Only

SFR Address = 0x44

RESET = x0xx-xx01

7	6	5	4	3	2	1	0
--	AWBOD0	--	--	--	--	BO0RE	1
W	W	W	W	W	W	W	W

Bit 7: Reserved. Software must write “0” on this bit when PCON2 is written.

Bit 2: AWBOD0, Awaked BOD0 in PD mode.

0: BOD0 is disabled in power-down mode.

1: BOD0 keeps operation in power-down mode.

Bit 5~2: Reserved. Software must write “0” on these bits when PCON2 is written.

Bit 1: BO0RE, BOD0 Reset Enabled. Its initial value could be changed by hardware option, BO0REO.

0: Disable BOD0 to trigger a system reset when BOF0 is set.

1: Enable BOD0 to trigger a system reset when BOF0 is set by VDD meets 4.2V(E) or 2.4V(L).

Bit 0: Reserved for test. Software must write “1” on this bit when PCON2 is written.

SPCON0: SFR Page Control 0

SFR Page = Page P Only

SFR Address = 0x48

RESET = xxx0-x000

7	6	5	4	3	2	1	0
--	--	--	WRCTL	--	CKCTL0	PWCTL1	PWCTL0
W	W	W	W	W	W	W	W

Bit 7~5: Reserved. Software must write “0” on these bits when SPCON0 is written.

Bit 4: WRCTL. WDTCR SFR access Control.

If WRCTL is set, it will disable the WDTCR SFR modified in general Page. WDTCR in general Page only keeps the SFR read function. But software always owns the modification capability in SFR Page P.

Bit 3: Reserved. Software must write “0” on this bit when SPCON0 is written.

Bit 2: CKCTL0. CKCON0 SFR access Control.

If CKCTL0 is set, it will disable the CKCON0 SFR modified in general Page. CKCON0 in general Page only keeps the SFR read function. But software always owns the modification capability in SFR Page P.

Bit 1: PWCTL1. PCON1 SFR access Control.

If PWCTL1 is set, it will disable the PCON1 SFR modified in general Page. PCON1 in general Page only keeps the SFR read function. But software always owns the modification capability in SFR Page P.

Bit 0: PWCTL0. PCON0 SFR access Control.

If PWCTL0 is set, it will disable the PCON0 SFR modified in general Page. PCON0 in general Page only keeps the SFR read function. But software always owns the modification capability in SFR Page P.

DCON0: Device Control 0

SFR Page = Page P Only

SFR Address = 0x4C

RESET = 00xx-xx1x

7	6	5	4	3	2	1	0
HSE	IAPO	--	--	--	--	RSTIO	--
W	W	W	W	W	W	W	W

Bit 7: HSE, High Speed operation Enable.

0: Disable high speed operation for MCU.

1: Enable high speed operation for MCU. ($F_{SYSCLK} > 12\text{MHz}$)

Bit 6: IAPO, IAP function Only.

0: Maintain IAP region to service IAP function and code execution.

1: Disable the code execution in IAP region and the region only service IAP function.

Bit 5~2: Reserved. Software must write "0" on these bits when DCON0 is written.

Bit 1: RSTIO, RST function on I/O,

0: Select I/O pad function for P36.

1: Select I/O pad function for RST.

Bit 0: Reserved. Software must write "0" on this bit when DCON0 is written.

18.1. Page-P Sample Code

(1). Required Function: General function call of Page-P SFR Read

Assembly Code Example:

```
_page_p_sfr_read:
page_p_sfr_read:
    MOV    IFADRH,000h
    MOV    IFMT,#(MS2|MS0)          ; PageP_Read=0x05

    ANL    ISPCR,#CFAIL
    ORL    ISPCR,#ISPEN            ; Enable Function

    MOV    SCMD,#046h
    MOV    SCMD,#0B9h

    MOV    IFMT,#000h              ; Flash_Standby=0x00
    ANL    ISPCR,#~ISPEN          ; Disable Function

    RET
```

C Code Example:

```
void page_p_sfr_read (void)
{
    IFADRH = 0x00;                //
    ISPCR = ISPEN;                // Enable Function
    IFMT = (MS0 | MS2);          // PageP_Read=0x05

    SCMD = 0x46;                 //
    SCMD = 0xB9;                 //

    IFMT = Flash_Standby;        // Flash_Standby=0x00
    ISPCR &= ~ISPEN;

}
```

(2). Required Function: General function call of Page-P SFR Write

Assembly Code Example:

```
_page_p_sfr_write:
page_p_sfr_write:
    MOV    IFADRH,000h
    MOV    ISPCR,#ISPEN            ; Enable Function
    MOV    IFMT,#MS2              ; PageP_Write=0x04

    MOV    SCMD,#046h
    MOV    SCMD,#0B9h

    MOV    IFMT,#000h              ; Flash_Standby=0x00
    ANL    ISPCR,#~ISPEN          ; Disable Function

    RET
```

C Code Example:

```
void page_p_sfr_write (void)
{
    IFADRH = 0x00;

    ISPCR = ISPEN;                // Enable Function
    IFMT = MS2;                   // PageP_Write=0x04

    SCMD = 0x46;                 //
    SCMD = 0xB9;                 //
}
```

```

IFMT = Flash_Standby;           // Flash_Standby=0x00
ISPCR &= ~ISPEN;
}

```

(3). Required Function: Enable PWCTL0 for PCON0.PD control in Page-P

Assembly Code Example:

```

MOV    IFADRL,#SPCON0           ;
CALL   page_p_sfr_read          ;

ORL    IFD,#PWCTL0              ; Set PWCTL0
CALL   page_p_sfr_write         ;

MOV    IFD,PCON0                ; Read PCON0

ORL    IFD,#PD                  ; Write PCON0 and Power-Down
MOV    IFADRL,#PCON0_P         ;
CALL   page_p_sfr_write         ;

```

C Code Example:

```

IFADRL = SPCON0;                //
page_p_sfr_read();              //

IFD |= PWCTL0;                  // Set PWCTL0
page_p_sfr_write();             //

IFD = PCON0;                    // Read PCON0

IFD |= PD;                      // Write PCON0
IFADRL = PCON0_P;               //
page_p_sfr_write();             //

```

(4). Required Function: Enable CKCTL0 for SYSCLK divider (CKCON0) changed in Page-P

Assembly Code Example:

```

MOV    IFADRL,#SPCON0           ;
CALL   page_p_sfr_read          ;

ORL    IFD,#CKCTL0              ; Set CKCTL0
CALL   page_p_sfr_write         ;

MOV    IFD,CKCON0               ; Read CKCON0

ORL    IFD,#(AFS | SCKS0)       ; Write CKCON0 and Set AFS
MOV    IFADRL,#CKCON0_P        ; SYSCLK / 2
CALL   page_p_sfr_write         ;

```

C Code Example:

```

IFADRL = SPCON0;                //
page_p_sfr_read ();             //

IFD |= CKCTL0;                  // Set CKCTL
page_p_sfr_write();             //

IFD = CKCON0;                   // read CKCON0

IFD |= (AFS | SCKS0);           //
IFADRL = CKCON0_P;              //
page_p_sfr_write();             // Write CKCON0

```

19. Auxiliary SFRs

AUXR0: Auxiliary Register 0

SFR Page = Normal

SFR Address = 0xA1

RESET = 0000-0000

7	6	5	4	3	2	1	0
P4OOC1	P4OOC0	P40FD	--	P1FS1	P1FS0	INT1H	INT0H
R/W	R/W	R/W	W	R/W	R/W	R/W	R/W

Bit 7~6: P4.0 function configured control bit 1 and 0. The two bits only act when internal RC oscillator (IHRCO or ILRCO) is selected for system clock source. In crystal mode, XTAL2 and XTAL1 are the alternated function for P4.0 and P4.1. In external clock input mode, P4.0 is the dedicated clock input pin. In internal oscillator condition, P4.0 provides the following selections for GPIO or clock source generator. When P4OOC[1:0] index to non-P4.0 GPIO function, P4.0 will drive the on-chip RC oscillator (IHRCO or ILRCO) output to provide the clock source for other devices.

P4OOC[1:0]	P4.0 function	P4.0 I/O mode
00	P40	By P4M0.0
01	OSCin	By P4M0.0
10	OSCin/2	By P4M0.0
11	OSCin/4	By P4M0.0

For clock-out on P4.0 function, it is recommended to set P4M0.0 to "1" which selects P4.0 as push-push output mode.

Bit 5: P40FD, P4.0 Fast Driving.

0: P4.0 output with default driving.

1: P4.0 output with fast driving enabled. If P6.0 is configured to clock output, enable this bit when P6.0 output frequency is more than 12MHz at 5V application or more than 6MHz at 3V application.

Bit 4: Reserved. Software must write "0" on this bit when AUXR0 is written.

Bit 3~2: P1.4 and P1.5 alternated function selection.

P1FS[1:0]	P1.4	P1.5
00	P1.4	P1.5
01	--	Output for TXD1
10	Input for nINT0	Input for nINT1
11	Input for T0	Input for T1

Bit 1: INT1H, INT1 High/Rising trigger enable.

0: Remain INT1 triggered on low level or falling edge on P3.3.

1: Set INT1 triggered on high level or rising edge on P3.3.

Bit 0: INT0H, INT0 High/Rising trigger enable.

0: Remain INT0 triggered on low level or falling edge on P3.2.

1: Set INT0 triggered on high level or rising edge on P3.2.

AUXR1: Auxiliary Control Register 1

SFR Page = Normal

SFR Address = 0xA2

RESET = 0000-0000

7	6	5	4	3	2	1	0
RTX3E	RTX2E	RTX1E	RTX0E	--	--	RXCS1	RXCS0
R/W	R/W	R/W	R/W	W	W	R/W	R/W

Bit 7: RTX3E, RXD Repeat to TXD3 enabled.

0: Disable RTX3E function on TXD3 (P1.5).

1: Enable the RXD repeat mechanism on TXD3 (P1.5).

Bit 6: RTX2E, RXD Repeat to TXD2 enabled.
 0: Disable RTX2E function on TXD2 (P1.3).
 1: Enable the RXD repeat mechanism on TXD3 (P1.3).

Bit 5: RTX1E, RXD Repeat to TXD1 enabled.
 0: Disable RTX1E function on TXD1 (P1.2).
 1: Enable the RXD repeat mechanism on TXD1 (P1.2).

Bit 4: RTX0E, RXD Repeat to TXD0 enabled.
 0: Disable RTX0E function on TXD0 (P3.1).
 1: Enable the RXD repeat mechanism on TXD0 (P3.1).

Bit 3~2: Reserved. Software must write “0” on these bits when AUXR1 is written.

Bit 1~0: RXD channel selection.

RXCS[1:0]	RXD channel selection
00	P3.0
01	P3.2
10	P3.3
11	P1.4

AUXR2: Auxiliary Register 2

SFR Page = Normal

SFR Address = 0xA3

RESET = 0000-0000

7	6	5	4	3	2	1	0
URXR	BTI	URM0X6	SMOD2	T1X12	T0X12	T1CKOE	T0CKOE
R/W	R/W	R/W	R/W	R/W	R/W	R/W	R/W

Bit 7: URXR, Serial Port test mode. Software must write “0” on this bit when AUXR2 is written.

Bit 6: BTI, Block TI in Serial Port Interrupt.
 0: Retain the TI to be a source of Serial Port Interrupt.
 1: Block TI to be a source of Serial Port Interrupt.

Bit 5: URM0X6, Serial Port mode 0 baud rate selector.
 0: Clear to select SYSCLK/12 as the baud rate for UART Mode 0.
 1: Set to select SYSCLK/2 as the baud rate for UART Mode 0.

Bit 4: SMOD2, extra X2/X4 baud rate selector.
 0: Disable extra X2/X4 baud rate.
 1: Enable extra X2/X4 baud rate.

Bit 3: T1X12, Timer 1 clock source selector while C/T=0.
 0: Clear to select SYSCLK/12.
 1: Set to select SYSCLK as the clock source.

Bit 2: T0X12, Timer 0 clock source selector while C/T=0.
 0: Clear to select SYSCLK/12.
 1: Set to select SYSCLK as the clock source.

Bit 1: T1CKOE, Timer 1 Clock Output Enable.
 0: Disable Timer 1 clock output.
 1: Enable Timer 1 clock output on P3.5.

Bit 0: T0CKOE, Timer 0 Clock Output Enable.
 0: Disable Timer 0 clock output.
 1: Enable Timer 0 clock output on P3.4.

20. Hardware Option

The MCU's Hardware Option defines the device behavior which cannot be programmed or controlled by software. The hardware options can only be programmed by a Universal Programmer, the "Megawin 8051 Writer U1" or the "Megawin 8051 ICE Adapter" (The ICE adapter also supports ICP programming function. Refer Section "21.4 ICP Interface Circuit"). After whole-chip erased, all the hardware options are left in "disabled" state and there is no ISP-memory and IAP-memory configured. The **MG86FE/L104** has the following Hardware Options:

LOCK:

- : Enabled. Code dumped on a universal Writer or Programmer is locked to 0xFF for security.
- : Disabled. Not locked.

ISP-memory Space:

The ISP-memory space is specified by its starting address. And, its higher boundary is limited by the Flash end address, i.e., 0xFFFF. The following table lists the ISP space option in this chip. In default setting, **MG86FE/L104** ISP space is configured to 1K that had been embedded Megawin proprietary ISP code to perform In-System-Programming through Megawin 1-Line ISP protocol.

ISP-memory Size	ISP Start Address
3.5K bytes	0x0200
3K bytes	0x0400
2.5K bytes	0x0600
2K bytes	0x0800
1.5K bytes	0x0A00
1K bytes	0x0C00
0.5K bytes	0x0E00
No ISP Space	--

HWBS:

- : Enabled. When powered up, MCU will boot from ISP-memory if ISP-memory is configured.
- : Disabled. MCU always boots from AP-memory.

HWBS2:

- : Enabled. Not only power-up but also any reset will cause MCU to boot from ISP-memory if ISP-memory is configured.
- : Disabled. Where MCU boots from is determined by HWBS.

IAP-memory Space:

The IAP-memory space specifies the user defined IAP space. The IAP-memory Space can be configured by hardware option or MCU software by modifying IAPLB. In default, it is configured to 1K bytes.

BO0REO:

- : Enabled. BOD0 will trigger a RESET event to CPU on AP program start address. (2.2V)
- : Disabled. BOD0 can not trigger a RESET to CPU.

WRENO:

- : Enabled. Set WDTCR.WREN to enable a system reset function by WDTF.
- : Disabled. Clear WDTCR.WREN to disable the system reset function by WDTF.

NSWDT: Non-Stopped WDT

- : Enabled. Set WDTCR.NSW to enable the WDT running in power down mode (watch mode).
- : Disabled. Clear WDTCR.NSW to disable the WDT running in power down mode (disable Watch mode).

HWENW: Hardware loaded for "ENW" of WDTCR.

- : Enabled. Enable WDT and load the content of WRENO, NSWDT, HWWIDL and HWPS2~0 to WDTCR after power-on.

: Disabled. WDT is not enabled automatically after power-on.

HWWIDL, HWPS2, HWPS1, HWPS0:

When HWENW is enabled, the content on these four fused bits will be loaded to WDTCR SFR after power-on.

WDSFWP:

: Enabled. The WDT SFRs, WREN, NSW, WIDL, PS2, PS1 and PS0 in WDTCR, will be write-protected.

: Disabled. The WDT SFRs, WREN, NSW, WIDL, PS2, PS1 and PS0 in WDTCR, are free for writing of software.

P36EN:

: Enabled. RSTIO (DCON0.1) will be cleared and P3.6 function behaves on RST pin.

: Disabled. RSTIO (DCON0.1) will be set and reserve RST pin function.

21. Application Notes

21.1. Power Supply Circuit

To have the **MG86FE/L104** work with power supply varying from 4.2V to 5.5V for E-type and from 2.4V to 3.6V for L-type, adding some external decoupling and bypass capacitors is necessary, as shown in [Figure 21–1](#).

Figure 21–1. Power Supplied Circuit

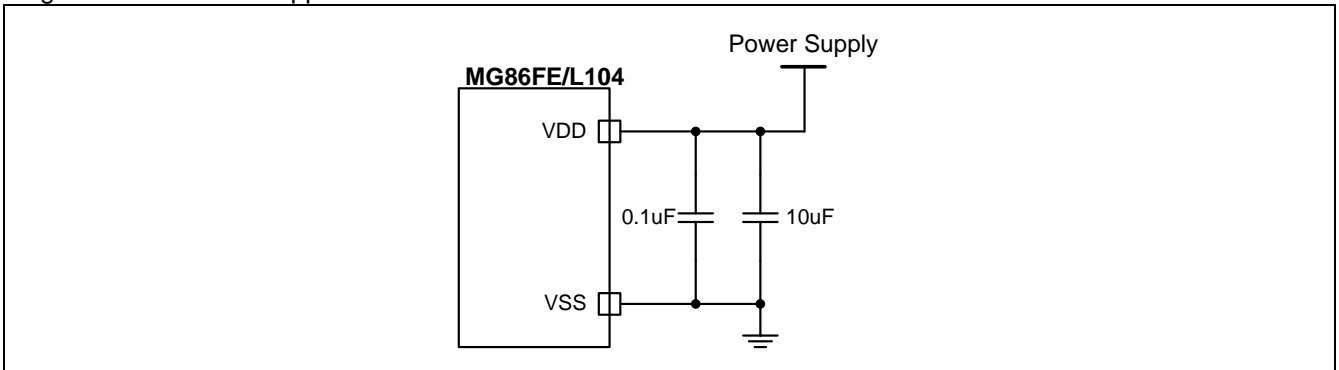

21.2. Reset Circuit

Normally, the power-on reset can be successfully generated during power-up. However, to further ensure the MCU a reliable reset during power-up, the external reset is necessary. [Figure 21–2](#) shows the external reset circuit, which consists of a capacitor C_{EXT} connected to VDD (power supply) and a resistor R_{EXT} connected to VSS (ground).

In general, R_{EXT} is optional because the RST pin has an internal pull-down resistor (R_{RST}). This internal diffused resistor to VSS permits a power-up reset using only an external capacitor C_{EXT} to VDD.

See Section “[22.2 DC Characteristics](#)” for R_{RST} value.

Figure 21–2. Reset Circuit

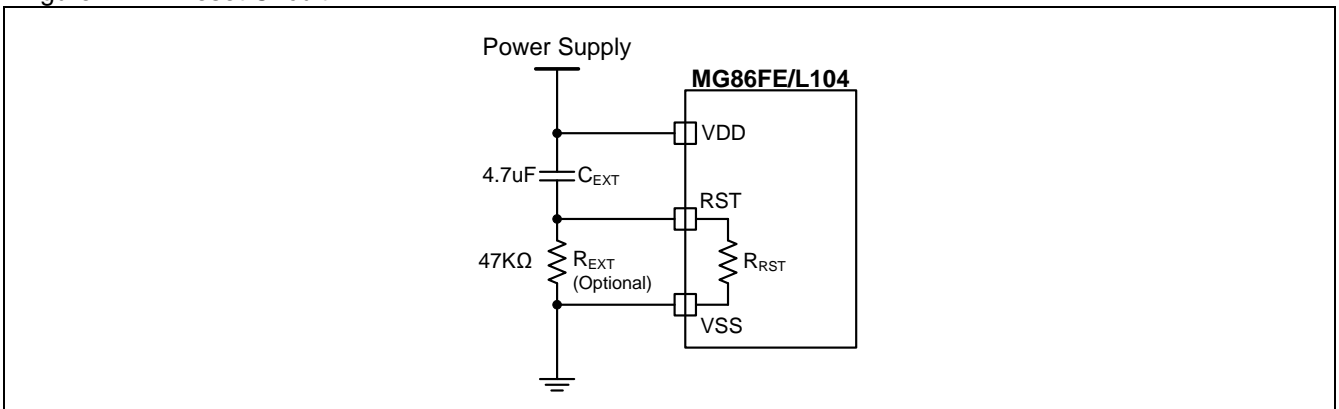

21.3. XTAL Oscillating Circuit

To achieve successful and exact oscillating (up to 24MHz), the capacitors C1 and C2 are necessary, as shown in Figure 21–3. Normally, C1 and C2 have the same value. Table 21–1 lists the C1 & C2 value for the different frequency crystal application.

Figure 21–3. XTAL Oscillating Circuit

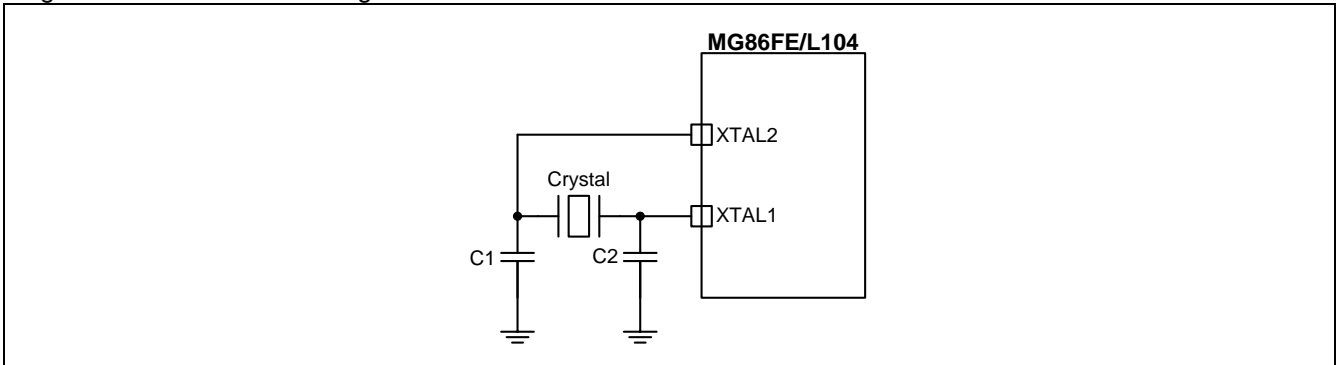

Table 21–1. Reference Capacitance of C1 & C2 for crystal oscillating circuit

Crystal	C1, C2 Capacitance
16MHz ~ 25MHz	10pF
6MHz ~ 16MHz	15pF
2MHz ~ 6MHz	33pF

21.4. ICP Interface Circuit

MG86FE/L104 devices include an on-chip Megawin proprietary programming interface to allow In-Chip-Programming (ICP) with the production part installed in the end application. The ICP interface uses a clock signal (ICP_SCL) and a bi-directional data signal (ICP_SDA) to perform the device programming from a host instruction.

The ICP interface allows the ICP_SCL/ICP_SDA pins to be shared with user functions so that In-Chip Flash Programming function could be performed. This is practicable because ICP communication is performed when the device is in the halt state, where the on-chip peripherals and user software are stalled. In this halted state, the ICP interface can safely 'borrow' the ICP_SCL (P1.6) and ICP_SDA (P1.5) pins. In most applications, external resistors are required to isolate ICP interface traffic from the user application. A typical isolation configuration is shown in Figure 21–4.

It is strongly recommended to build the ICP interface circuit on target system. It will reserve the whole capability for software programming and device options configured.

Note: MG86FE/L104AS8 does not support ICP interface.

Figure 21–4. ICP Interface Circuit

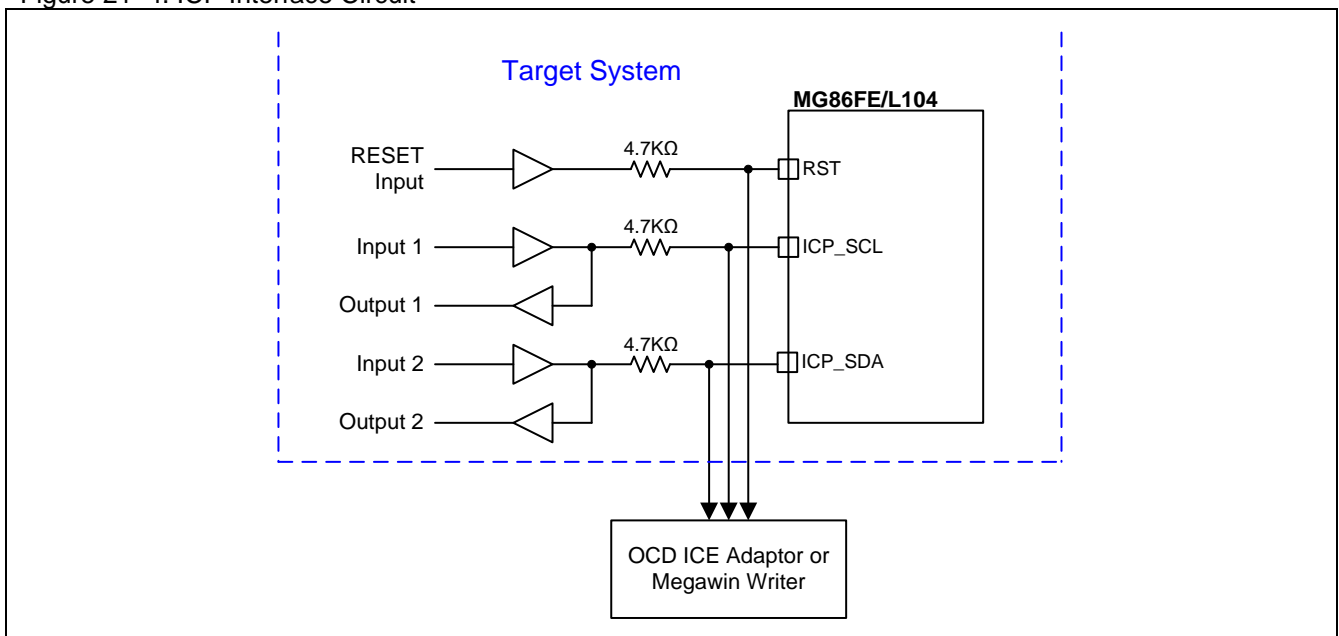

22. Electrical Characteristics

22.1. Absolute Maximum Rating

For MG86FE104:

Parameter	Rating	Unit
Ambient temperature under bias	-40 ~ +85	°C
Storage temperature	-65 ~ + 150	°C
Voltage on any Port I/O Pin or RST with respect to VSS	-0.5 ~ VDD + 0.5	V
Voltage on VDD with respect to VSS	-0.5 ~ +6.0	V
Maximum total current through VDD and VSS	200	mA
Maximum output current sunk by any Port pin	40	mA

*Note: stresses above those listed under “Absolute Maximum Ratings” may cause permanent damage to the device. This is a stress rating only and functional operation of the devices at those or any other conditions above those indicated in the operation listings of this specification is not implied. Exposure to maximum rating conditions for extended periods may affect device reliability.

For MG86FL104:

Parameter	Rating	Unit
Ambient temperature under bias	-40 ~ +85	°C
Storage temperature	-65 ~ + 150	°C
Voltage on any Port I/O Pin or RESET with respect to Ground	-0.3 ~ VDD + 0.3	V
Voltage on VDD with respect to Ground	-0.3 ~ +4.2	V
Maximum total current through VDD and Ground	200	mA
Maximum output current sunk by any Port pin	40	mA

*Note: stresses above those listed under “Absolute Maximum Ratings” may cause permanent damage to the device. This is a stress rating only and functional operation of the devices at those or any other conditions above those indicated in the operation listings of this specification is not implied. Exposure to maximum rating conditions for extended periods may affect device reliability.

22.2. DC Characteristics

For MG86FE104:

VDD = 5.0V±10%, VSS = 0V, T_A = 25 °C and execute NOP for each machine cycle, unless otherwise specified

Symbol	Parameter	Test Condition	Limits			Unit
			min	typ	max	
Input/Output Characteristics						
V _{IH1}	Input High voltage (All I/O Ports)	Except P4.0, P4.1	2.0			V
V _{IH2}	Input High voltage (RST, P4.0, P4.1)		3.5			V
V _{IL1}	Input Low voltage (All I/O Ports)	Except P6.0, P6.1			0.8	V
V _{IL2}	Input Low voltage (RST, P6.0, P6.1)				1.0	V
I _{IH}	Input High Leakage current (All I/O Ports)	V _{PIN} = VDD		0	10	uA
I _{IL1}	Logic 0 input current (P3 in quasi-mode)	V _{PIN} = 0.4V		28	60	uA
I _{IL2}	Logic 0 input current (All Input only or open-drain Ports)	V _{PIN} = 0.4V		0	10	uA
I _{H2L}	Logic 1 to 0 input transition current (P3 in quasi-mode)	V _{PIN} = 1.8V		330	500	uA
I _{OH1}	Output High current (P3 in quasi-Mode)	V _{PIN} = 2.4V	150	200		uA
I _{OH2}	Output High current (All push-pull output ports)	V _{PIN} = 2.4V	12			mA
I _{OL1}	Output Low current (All I/O Ports)	V _{PIN} = 0.4V	12			mA
R _{RST}	Internal reset pull-down resistance			77		Kohm
Power Consumption						
I _{OP1}	Normal mode operating current	SYSClk = 24MHz @ IHRCO		8.5		mA
I _{OP2}		SYSClk = 12MHz @ IHRCO		5.9		mA
I _{OP3}		SYSClk = 6MHz @ IHRCO & HSE = 0		4.1		mA
I _{OP4}		SYSClk = 3MHz @ IHRCO & HSE = 0		2.4		mA
I _{OP5}		SYSClk = 24MHz @ XTAL		10		mA
I _{OP6}		SYSClk = 12MHz @ XTAL		6.9		mA
I _{OP7}		SYSClk = 6MHz @ XTAL & HSE = 0		5		mA
I _{OP8}		SYSClk = 2MHz @ XTAL & HSE = 0		2.5		mA
I _{OPS1}	Slow mode operating current	SYSClk = 24MHz/128 @ IHRCO		0.86		mA
I _{IDLE1}	Idle mode operating current	SYSClk = 24MHz @ IHRCO		2.1		mA
I _{IDLE2}		SYSClk = 24MHz @ XTAL		3.6		mA
I _{IDLE3}		SYSClk = 24MHz/128 @ IHRCO		0.77		mA
I _{IDLE4}		SYSClk = 24MHz/128 @ XTAL		2.2		mA
I _{IDLE5}		SYSClk = 64KHz @ ILRCO		16		uA
I _{SUB1}	Sub-clock mode operating current	SYSClk = 64KHz @ ILRCO, BOD0 disabled & HSE = 0		45		uA

I_{SUB2}		SYSClk = 64KHz/128 @ ILRCo, BOD0 disabled & HSE = 0		13		uA
I_{WAT}	Watch mode operating current	WDT = 64KHz @ ILRCo in PD mode		2.5		uA
I_{MON1}	Monitor Mode operating current	BOD0 enabled in PD mode		10		uA
BOD0 Characteristics						
V_{BOD0}	BOD0 detection level	$T_A = -40^{\circ}\text{C}$ to $+85^{\circ}\text{C}$	3.8 ⁽¹⁾	4.0	4.2 ⁽¹⁾	V
Operating Condition						
V_{PSR}	Power-on Slope Rate	$T_A = -40^{\circ}\text{C}$ to $+85^{\circ}\text{C}$	0.05			V/ms
V_{OP1}	Operating Speed 0–25MHz	$T_A = -40^{\circ}\text{C}$ to $+85^{\circ}\text{C}$	4.5		5.5	V
V_{OP2}	Operating Speed 0-12MHz	$T_A = -40^{\circ}\text{C}$ to $+85^{\circ}\text{C}$	4.2		5.5	V

⁽¹⁾Data based on characterization results, not tested in production.

For MG86FL104:

VDD = 3.3V±10%, VSS = 0V, T_A = 25 °C and execute NOP for each machine cycle, unless otherwise specified

Symbol	Parameter	Test Condition	Limits			Unit
			min	typ	max	
Input/Output Characteristics						
V _{IH1}	Input High voltage (All I/O Ports)	Except P4.0, P4.1	2.0			V
V _{IH2}	Input High voltage (RST, P4.0, P4.1)		2.4			V
V _{IL1}	Input Low voltage (All I/O Ports)	Except P6.0, P6.1			0.8	V
V _{IL2}	Input Low voltage (RST, P6.0, P6.1)				0.8	V
I _{IH}	Input High Leakage current (All I/O Ports)	V _{PIN} = VDD		0	10	uA
I _{IL1}	Logic 0 input current (P3 in quasi-mode)	V _{PIN} = 0.4V		10	30	uA
I _{IL2}	Logic 0 input current (All Input only or open-drain Ports)	V _{PIN} = 0.4V		0	10	uA
I _{H2L}	Logic 1 to 0 input transition current (P3 in quasi-mode)	V _{PIN} =1.8V		120	250	uA
I _{OH1}	Output High current (P3 in quasi-Mode)	V _{PIN} =2.4V	40	80		uA
I _{OH2}	Output High current (All push-pull output ports)	V _{PIN} =2.4V	8			mA
I _{OL1}	Output Low current (All I/O Ports)	V _{PIN} =0.4V	8			mA
R _{RST}	Internal reset pull-down resistance			93		Kohm
Power Consumption						
I _{OP1}	Normal mode operating current	SYSClk = 24MHz @ IHRCO		8.8		mA
I _{OP2}		SYSClk = 12MHz @ IHRCO		5.7		mA
I _{OP3}		SYSClk = 6MHz @ IHRCO & HSE = 0		4		mA
I _{OP4}		SYSClk = 3MHz @ IHRCO & HSE = 0		2.4		mA
I _{OP5}		SYSClk = 24MHz @ XTAL		8.9		mA
I _{OP6}		SYSClk = 12MHz @ XTAL		5.6		mA
I _{OP7}		SYSClk = 6MHz @ XTAL & HSE = 0		3.8		mA
I _{OP8}		SYSClk = 2MHz @ XTAL & HSE = 0		1.6		mA
I _{OPS1}	Slow mode operating current	SYSClk = 24MHz/128 @ IHRCO		0.86		mA
I _{IDLE1}	Idle mode operating current	SYSClk = 24MHz @ IHRCO		2.1		mA
I _{IDLE2}		SYSClk = 24MHz @ XTAL		2.3		mA
I _{IDLE3}		SYSClk = 24MHz/128 @ IHRCO		0.77		mA
I _{IDLE4}		SYSClk = 24MHz/128 @ XTAL		0.88		mA
I _{IDLE5}		SYSClk = 64KHz @ ILRCO		16		uA
I _{SUB1}	Sub-clock mode operating current	SYSClk = 64KHz @ ILRCO, BOD0 disabled & HSE = 0		45		uA

I_{SUB2}		SYSClk = 64KHz/128 @ ILRCo, BOD0 disabled & HSE = 0		13		uA
I_{WAT}	Watch mode operating current	WDT = 64KHz @ ILRCo in PD mode		2.5		uA
I_{MON1}	Monitor Mode operating current	BOD0 enabled in PD mode		10		uA
BOD0 Characteristics						
V_{BOD0}	BOD0 detection level	$T_A = -40^{\circ}\text{C}$ to $+85^{\circ}\text{C}$	2.45 ⁽¹⁾	2.6	2.75 ⁽¹⁾	V
Operating Condition						
V_{PSR}	Power-on Slope Rate	$T_A = -40^{\circ}\text{C}$ to $+85^{\circ}\text{C}$	0.05			V/ms
V_{OP1}	Operating Speed 0–25MHz	$T_A = -40^{\circ}\text{C}$ to $+85^{\circ}\text{C}$	2.7		3.6	V
V_{OP2}	Operating Speed 0-12MHz	$T_A = -40^{\circ}\text{C}$ to $+85^{\circ}\text{C}$	2.4		3.6	V

⁽¹⁾Data based on characterization results, not tested in production.

22.3. External Clock Characteristics

For MG86FE104:

VDD = 4.5V ~ 5.5V, VSS = 0V, T_A = -40°C to +85°C, unless otherwise specified

Symbol	Parameter	Oscillator				Unit
		Crystal Mode		ECKI Mode		
		Min.	Max	Min.	Max	
1/t _{CLCL}	Oscillator Frequency	2	25	0	25	MHz
1/t _{CLCL}	Oscillator Frequency (VDD = 4.2V ~ 5.5V)	2	12	0	12	MHz
t _{CLCL}	Clock Period	40		40		ns
t _{CHCX}	High Time	0.4T	0.6T	0.4T	0.6T	t _{CLCL}
t _{CLCX}	Low Time	0.4T	0.6T	0.4T	0.6T	t _{CLCL}
t _{CLCH}	Rise Time		5		5	ns
t _{CHCL}	Fall Time		5		5	ns

For MG86FL104:

VDD = 2.7V ~ 3.6V, VSS = 0V, T_A = -40°C to +85°C, unless otherwise specified

Symbol	Parameter	Oscillator				Unit
		Crystal Mode		ECKI Mode		
		Min.	Max	Min.	Max	
1/t _{CLCL}	Oscillator Frequency	2	25	0	25	MHz
1/t _{CLCL}	Oscillator Frequency (VDD = 2.4V ~ 3.6V)	2	12	0	12	MHz
t _{CLCL}	Clock Period	40		40		ns
t _{CHCX}	High Time	0.4T	0.6T	0.4T	0.6T	t _{CLCL}
t _{CLCX}	Low Time	0.4T	0.6T	0.4T	0.6T	t _{CLCL}
t _{CLCH}	Rise Time		5		5	ns
t _{CHCL}	Fall Time		5		5	ns

Figure 22–1. External Clock Drive Waveform

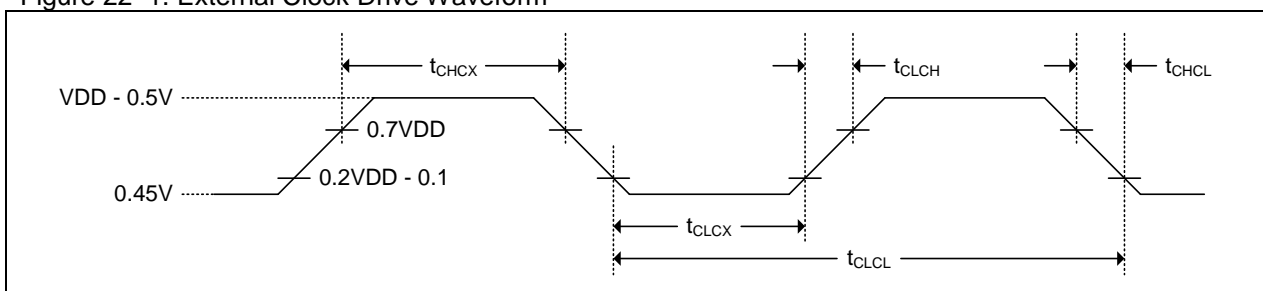

22.4. IHRCO Characteristics

For MG86FE104:

Parameter	Test Condition	Limits			Unit
		min	typ	max	
Supply Voltage		4.5		5.5	V
IHRCO Frequency	TA = +25°C, AFS = 0		24		MHz
	TA = +25°C, AFS = 1		22.118		MHz
IHRCO Frequency Deviation (factory calibrated)	TA = +25°C	-1.0		+1.0	%
	TA = -40°C to +85°C	-4.0 ⁽¹⁾		+4.0 ⁽¹⁾	%
IHRCO Start-up Time	TA = -40°C to +85°C			32 ⁽¹⁾	us
IHRCO Power Consumption	TA = +25°C, VDD=5.0V		770		uA

⁽¹⁾ Data based on characterization results, not tested in production.

For MG86FL104:

Parameter	Test Condition	Limits			Unit
		min	typ	max	
Supply Voltage		2.7		3.6	V
IHRCO Frequency	TA = +25°C, AFS = 0		24		MHz
	TA = +25°C, AFS = 1		22.118		MHz
IHRCO Frequency Deviation (factory calibrated)	TA = +25°C	-1.0		+1.0	%
	TA = -40°C to +85°C	-4.0 ⁽¹⁾		+4.0 ⁽¹⁾	%
IHRCO Start-up Time	TA = -40°C to +85°C			32 ⁽¹⁾	us
IHRCO Power Consumption	TA = +25°C, VDD=5.0V		770		uA

⁽¹⁾ Data based on characterization results, not tested in production.

22.5. ILRCO Characteristics

For MG86FE104:

Parameter	Test Condition	Limits			Unit
		min	typ	max	
Supply Voltage		4.2		5.5	V
ILRCO Frequency	TA = +25°C		64		KHz
ILRCO Frequency Deviation	TA = +25°C	-20 ⁽¹⁾		+20 ⁽¹⁾	%
	TA = -40°C to +85°C	-40 ⁽¹⁾		+40 ⁽¹⁾	%

⁽¹⁾ Data based on characterization results, not tested in production.

For MG86FL104:

Parameter	Test Condition	Limits			Unit
		min	typ	max	
Supply Voltage		2.4		3.6	V
ILRCO Frequency	TA = +25°C		64		KHz
ILRCO Frequency Deviation	TA = +25°C	-20 ⁽¹⁾		+20 ⁽¹⁾	%
	TA = -40°C to +85°C	-40 ⁽¹⁾		+40 ⁽¹⁾	%

⁽¹⁾ Data based on characterization results, not tested in production.

22.6. Flash Characteristics

For MG86FE104:

Parameter	Test Condition	Limits			Unit
		min	typ	max	
Supply Voltage	TA = -40°C to +85°C	4.2		5.5	V
Flash Write (Erase/Program) Voltage	TA = -40°C to +85°C	4.5		5.5	V
Flash Erase/Program Cycle	TA = -40°C to +85°C	100			times
Flash Data Retention	TA = +25°C	100			year

For MG86FL104:

Parameter	Test Condition	Limits			Unit
		min	typ	max	
Supply Voltage	TA = -40°C to +85°C	2.4		3.6	V
Flash Write (Erase/Program) Voltage	TA = -40°C to +85°C	2.7		3.6	V
Flash Erase/Program Cycle	TA = -40°C to +85°C	100			times
Flash Data Retention	TA = +25°C	100			year

22.7. Serial Port Timing Characteristics

For MG86FE104: VDD = 5.0V±10%, VSS = 0V, TA = -40°C to +85°C, unless otherwise specified

For MG86FL104: VDD = 3.3V±10%, VSS = 0V, TA = -40°C to +85°C, unless otherwise specified

Symbol	Parameter	URM0X6 = 0		URM0X6 = 1		Unit
		Min.	Max	Min.	Max	
t _{XLXL}	Serial Port Clock Cycle Time	12T		2T		T _{SYSCLK}
t _{QVXH}	Output Data Setup to Clock Rising Edge	10T-20		T-20		ns
t _{XHQX}	Output Data Hold after Clock Rising Edge	T-10		T-10		ns
t _{XHDX}	Input Data Hold after Clock Rising Edge	0		0		ns
t _{XHDV}	Clock Rising Edge to Input Data Valid		10T-20		2T-20	ns

Figure 22–2. Shift Register Mode Timing Waveform

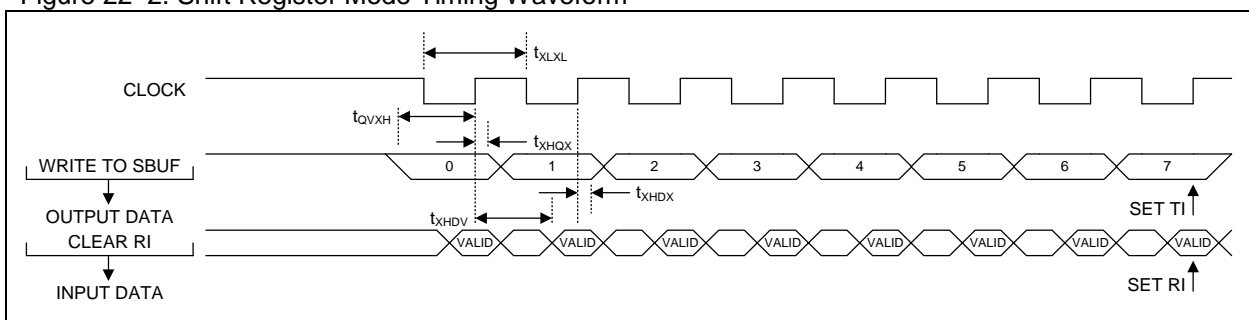

23. Instruction Set

Table 23–1. Instruction Set

MNEMONIC	DESCRIPTION	BYTE	EXECUTION Cycles
DATA TRASFER			
MOV A,Rn	Move register to Acc	1	1
MOV A,direct	Move direct byte o Acc	2	2
MOV A,@Ri	Move indirect RAM to Acc	1	2
MOV A,#data	Move immediate data to Acc	2	2
MOV Rn,A	Move Acc to register	1	2
MOV Rn,direct	Move direct byte to register	2	4
MOV Rn,#data	Move immediate data to register	2	2
MOV direct,A	Move Acc to direct byte	2	3
MOV direct,Rn	Move register to direct byte	2	3
MOV direct,direct	Move direct byte to direct byte	3	4
MOV direct,@Ri	Move indirect RAM to direct byte	2	4
MOV direct,#data	Move immediate data to direct byte	3	3
MOV @Ri,A	Move Acc to indirect RAM	1	3
MOV @Ri,direct	Move direct byte to indirect RAM	2	3
MOV @Ri,#data	Move immediate data to indirect RAM	2	3
MOV DPTR,#data16	Load DPTR with a 16-bit constant	3	3
MOVC A,@A+DPTR	Move code byte relative to DPTR to Acc	1	4
MOVC A,@A+PC	Move code byte relative to PC to Acc	1	4
MOVX A,@Ri	Move on-chip auxiliary RAM(8-bit address) to Acc	1	Not Support
MOVX A,@DPTR	Move on-chip auxiliary RAM(16-bit address) to Acc	1	Not Support
MOVX @Ri,A	Move Acc to on-chip auxiliary RAM(8-bit address)	1	Not Support
MOVX @DPTR,A	Move Acc to on-chip auxiliary RAM(16-bit address)	1	Not Support
MOVX A,@Ri	Move external RAM(8-bit address) to Acc	1	Not Support
MOVX A,@DPTR	Move external RAM(16-bit address) to Acc	1	Not Support
MOVX @Ri,A	Move Acc to external RAM(8-bit address)	1	Not Support
MOVX @DPTR,A	Move Acc to external RAM(16-bit address)	1	Not Support
PUSH direct	Push direct byte onto Stack	2	4
POP direct	Pop direct byte from Stack	2	3
XCH A,Rn	Exchange register with Acc	1	3
XCH A,direct	Exchange direct byte with Acc	2	4
XCH A,@Ri	Exchange indirect RAM with Acc	1	4
XCHD A,@Ri	Exchange low-order digit indirect RAM with Acc	1	4
ARITHMETIC OPERATIONS			
ADD A,Rn	Add register to Acc	1	2
ADD A,direct	Add direct byte to Acc	2	3
ADD A,@Ri	Add indirect RAM to Acc	1	3
ADD A,#data	Add immediate data to Acc	2	2
ADDC A,Rn	Add register to Acc with Carry	1	2
ADDC A,direct	Add direct byte to Acc with Carry	2	3
ADDC A,@Ri	Add indirect RAM to Acc with Carry	1	3
ADDC A,#data	Add immediate data to Acc with Carry	2	2
SUBB A,Rn	Subtract register from Acc with borrow	1	2
SUBB A,direct	Subtract direct byte from Acc with borrow	2	3
SUBB A,@Ri	Subtract indirect RAM from Acc with borrow	1	3

SUBB A,#data	Subtract immediate data from Acc with borrow	2	2
INC A	Increment Acc	1	2
INC Rn	Increment register	1	3
INC direct	Increment direct byte	2	4
INC @Ri	Increment indirect RAM	1	4
DEC A	Decrement Acc	1	2
DEC Rn	Decrement register	1	3
DEC direct	Decrement direct byte	2	4
DEC @Ri	Decrement indirect RAM	1	4
INC DPTR	Increment DPTR	1	1
MUL AB	Multiply A and B	1	4
DIV AB	Divide A by B	1	5
DA A	Decimal Adjust Acc	1	4
LOGIC OPERATION			
ANL A,Rn	AND register to Acc	1	2
ANL A,direct	AND direct byte to Acc	2	3
ANL A,@Ri	AND indirect RAM to Acc	1	3
ANL A,#data	AND immediate data to Acc	2	2
ANL direct,A	AND Acc to direct byte	2	4
ANL direct,#data	AND immediate data to direct byte	3	4
ORL A,Rn	OR register to Acc	1	2
ORL A,direct	OR direct byte to Acc	2	3
ORL A,@Ri	OR indirect RAM to Acc	1	3
ORL A,#data	OR immediate data to Acc	2	2
ORL direct,A	OR Acc to direct byte	2	4
ORL direct,#data	OR immediate data to direct byte	3	4
XRL A,Rn	Exclusive-OR register to Acc	1	2
XRL A,direct	Exclusive-OR direct byte to Acc	2	3
XRL A,@Ri	Exclusive-OR indirect RAM to Acc	1	3
XRL A,#data	Exclusive-OR immediate data to Acc	2	2
XRL direct,A	Exclusive-OR Acc to direct byte	2	4
XRL direct,#data	Exclusive-OR immediate data to direct byte	3	4
CLR A	Clear Acc	1	1
CPL A	Complement Acc	1	2
RL A	Rotate Acc Left	1	1
RLC A	Rotate Acc Left through the Carry	1	1
RR A	Rotate Acc Right	1	1
RRC A	Rotate Acc Right through the Carry	1	1
SWAP A	Swap nibbles within the Acc	1	1
BOOLEAN VARIABLE MANIPULATION			
CLR C	Clear Carry	1	1
CLR bit	Clear direct bit	2	4
SETB C	Set Carry	1	1
SETB bit	Set direct bit	2	4
CPL C	Complement Carry	1	1
CPL bit	Complement direct bit	2	4
ANL C,bit	AND direct bit to Carry	2	3
ANL C,/bit	AND complement of direct bit to Carry	2	3
ORL C,bit	OR direct bit to Carry	2	3
ORL C,/bit	OR complement of direct bit to Carry	2	3

MOV C,bit	Move direct bit to Carry	2	3
MOV bit,C	Move Carry to direct bit	2	4
BOOLEAN VARIABLE MANIPULATION			
JC rel	Jump if Carry is set	2	3
JNC rel	Jump if Carry not set	2	3
JB bit,rel	Jump if direct bit is set	3	4
JNB bit,rel	Jump if direct bit not set	3	4
JBC bit,rel	Jump if direct bit is set and then clear bit	3	5
PROGRAM BRACHING			
ACALL addr11	Absolute subroutine call	2	6
LCALL addr16	Long subroutine call	3	6
RET	Return from subroutine	1	4
RETI	Return from interrupt subroutine	1	4
AJMP addr11	Absolute jump	2	3
LJMP addr16	Long jump	3	4
SJMP rel	Short jump	2	3
JMP @A+DPTR	Jump indirect relative to DPTR	1	3
JZ rel	Jump if Acc is zero	2	3
JNZ rel	Jump if Acc not zero	2	3
CJNE A,direct,rel	Compare direct byte to Acc and jump if not equal	3	5
CJNE A,#data,rel	Compare immediate data to Acc and jump if not equal	3	4
CJNE Rn,#data,rel	Compare immediate data to register and jump if not equal	3	4
CJNE @Ri,#data,rel	Compare immediate data to indirect RAM and jump if not equal	3	5
DJNZ Rn,rel	Decrement register and jump if not equal	2	4
DJNZ direct,rel	Decrement direct byte and jump if not equal	3	5
NOP	No Operation	1	1

24. Package Dimension

24.1. SOP-20

Figure 24-1. SOP-20

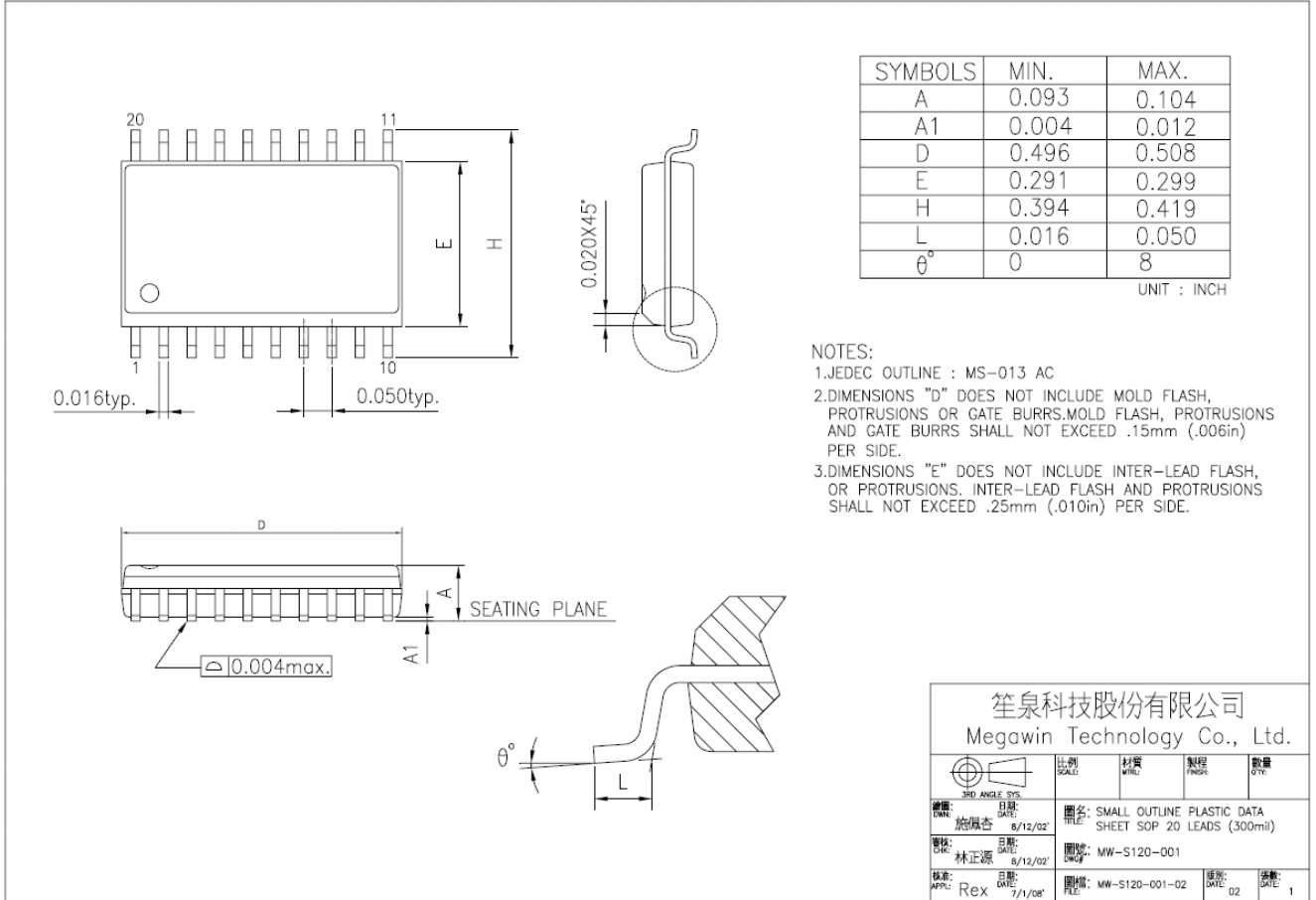

24.2. SOP-16

Figure 24-2. SOP-16

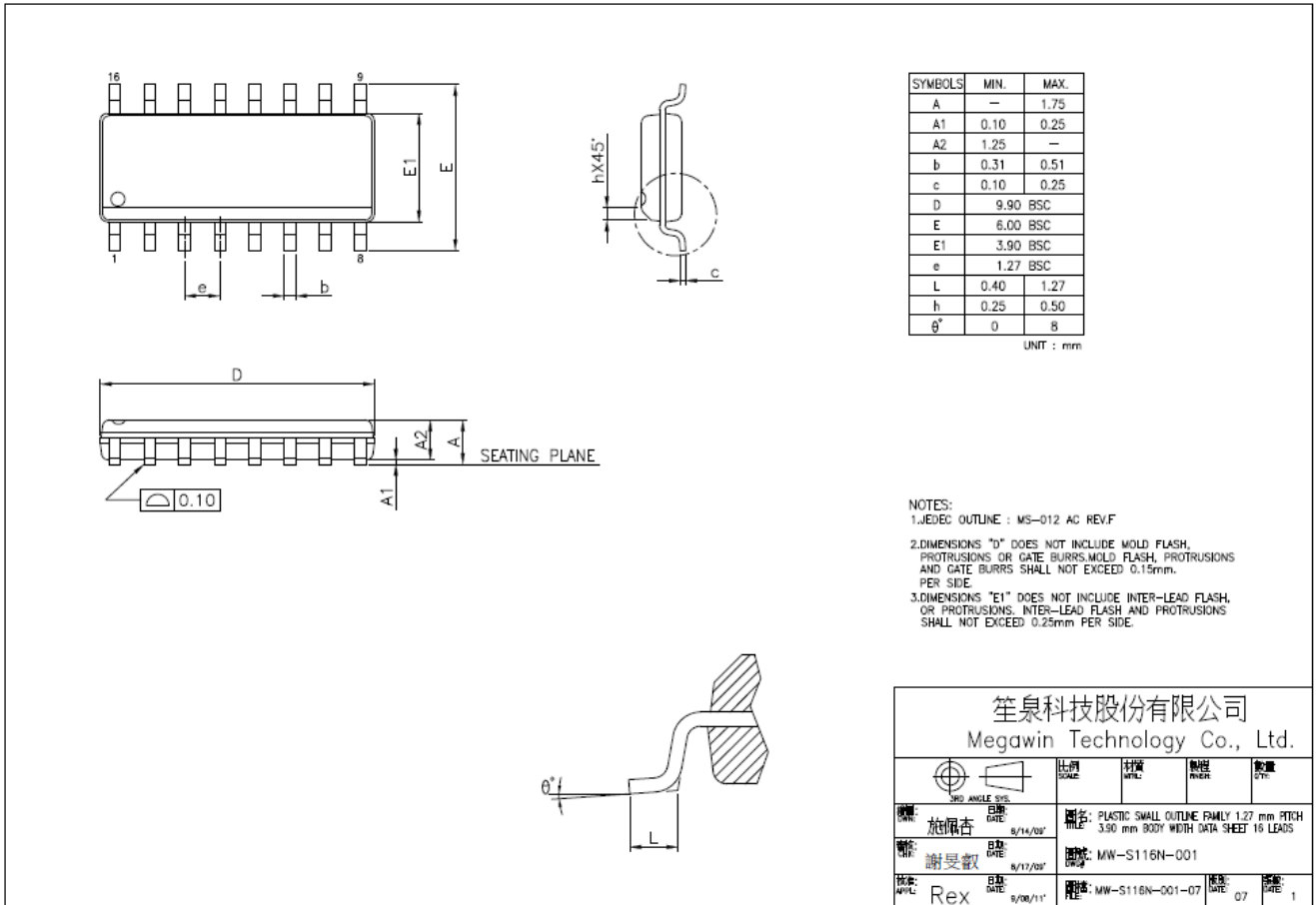

24.3. SOP-8

Figure 24-3. SOP-8

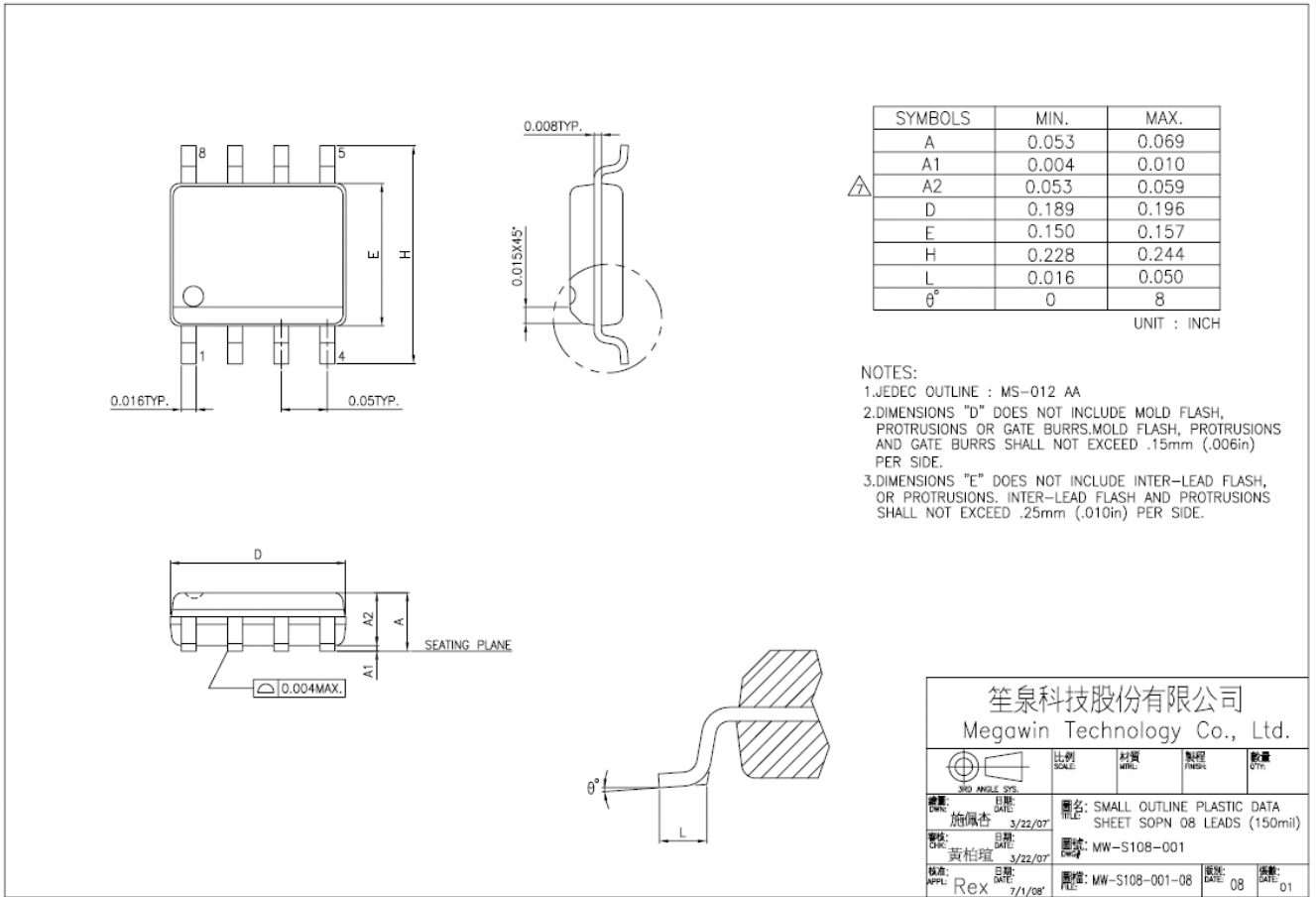

笙泉科技股份有限公司 Megawin Technology Co., Ltd.				
 3RD ANGLE SYS	比例 SCALE	材質 MATERIAL	制程 FINISH	數量 QTY
繪圖: 施佩杰 日期: 3/22/07	圖名: SMALL OUTLINE PLASTIC DATA SHEET SOPN 08 LEADS (150mil)			圖號: MW-S108-001
審核: 黃柏垣 日期: 3/22/07	繪圖: DWG	圖號: MW-S108-001-08	版次: 08	日期: 01
公司: Rex	日期: 7/1/08	圖號: MW-S108-001-08	版次: 08	日期: 01

25. Revision History

Table 25–1. Revision History

Rev	Descriptions	Date
v0.19	1. Release preliminary version, v0.19.	2011/02/25
V0.20	1. Modify to release format.	2012/01/11
	2. Merge Section “ISP” & “IAP” and modify Section “Electrical Characteristics”	2012/01/11
	3. Add Section “Application Note”	2012/01/11
	4. Delete DIP series package.	2012/01/18
	5. In Table. 13-1, modify I/O pin-out of SOP8 package	2012/01/18
	6. Add package dimension.	2012/01/19
	7. CKCON0.7 AFS bit, default 0 after reset should be IHRCO=24MHz	2012/09/24
A1	New Datasheet Format	2013/01/11
	Modify SMOD as SMOD1 in baudrate setting section.	2013/01/24
A1.2	Modify MTP write access cycle.	2013/09/04
A1.3	Modify IE SFR address error E8h as A8h.	2013/10/09
A1.4	Modify SOP-16 package dimension data 300mil to 150mil.	2014/03/31
A1.5	Modify SOP-16 package format	2015/05/27

Disclaimers

Herein, Megawin stands for “*Megawin Technology Co., Ltd.*”

Life Support — This product is not designed for use in medical, life-saving or life-sustaining applications, or systems where malfunction of this product can reasonably be expected to result in personal injury. Customers using or selling this product for use in such applications do so at their own risk and agree to fully indemnify Megawin for any damages resulting from such improper use or sale.

Right to Make Changes — Megawin reserves the right to make changes in the products - including circuits, standard cells, and/or software - described or contained herein in order to improve design and/or performance. When the product is in mass production, relevant changes will be communicated via an Engineering Change Notification (ECN).