

MGA-16116

Dual LNA for Balanced Application 450 – 1450 MHz



Data Sheet

Description

Avago Technologies' MGA-16116 is an ultra low-noise high linearity amplifier pair with built-in active bias and shutdown features for balanced applications in the 900 MHz band. Shutdown functionality is achieved using a single DC voltage input pin. High linearity is achieved through the use of Avago Technologies' proprietary GaAs Enhancement-mode pHEMT process¹. It is housed in a miniature 4.0 x 4.0 x 0.85 mm 16-pin Quad Flat No-lead (QFN). The compact footprint coupled with ultra low noise and high linearity makes MGA-16116 an ideal choice for basestation transmitters and receivers.

For applications > 1450 MHz, it is recommended to use MGA-16216 1440-2350 MHz or MGA-16316 1950-4000 MHz. All 3 products share the same package and pin out configuration.

Component Image

4.0 x 4.0 x 0.85 mm³ 16-Lead QFN



Note:
 Package marking provides orientation and identification
 "16116" = Device Code
 "YYWW" = Date Code identifies year and work week of manufacturing
 "XXXX" = Last 4 digit of assembly lot number

Pin Configuration

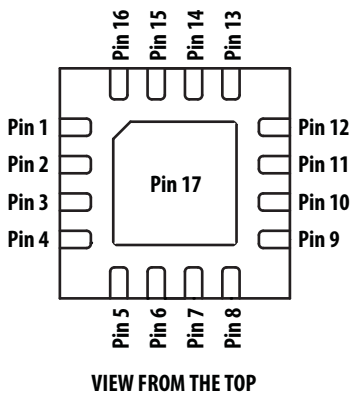

Pin	Use	Pin	Use
1	RFIN1	10	GND
2	GND	11	GND
3	GND	12	RFOUT1
4	RFIN2	13	Not used
5	Bias_out2	14	Bias_in1
6	Vsd2	15	Vsd1
7	Bias_in2	16	Bias_out1
8	Not used	17	GND
9	RFOUT2	-	-

Features

- Ultra Low Noise Figure
- Variable Bias and Shutdown functionality
- High IIP3: +19 dBm typ.
- GaAs E-pHEMT Technology^[1]
- Small package size: 4.0 x 4.0 x 0.85 mm³
- RoHS and MSL1 compliant.

Typical Performances

900 MHz @ 4.8 V, 60.9 mA (typ per amplifier)

- Gain: 18.4 dB
- NF: 0.27 dB^[2]
- IIP3: 19.1 dBm
- P1dB: 21.2 dBm
- Shutdown voltage Vsd range > 1.6 V
- Total shutdown current (Vsd1, Vsd2 = 3 V): 1.84 mA

Applications

- Basestation receivers and transmitters in balanced configuration.
- Ultra low-noise RF amplifiers.

Notes:

1. Enhancement mode technology employs positive Vgs, thereby eliminating the need of negative gate voltage associated with conventional depletion mode devices.
2. Measured at RFin pin of packaged part, other losses deembedded.
3. Good RF practice requires all unused pins to be grounded.



Attention: Observe precautions for handling electrostatic sensitive devices.
 ESD Machine Model = 60V
 ESD Human Body Model = 300V
 Refer to Avago Application Note A004R: Electrostatic Discharge, Damage and Control.

Absolute Maximum Rating^[1] $T_A = 25^\circ\text{C}$

Symbol	Parameter	Units	Absolute Maximum
V _{dd}	Drain Voltage, RF output to ground	V	5.5
I _{dd}	Drain Current	mA	100
V _{sd}	Shutdown Voltage	V	5.5
P _{in}	CW RF Input Power with LNA On	dBm	27
P _{in}	CW RF Input Power with LNA Off	dBm	27
P _d	Power Dissipation	mW	550
T _j	Junction Temperature	°C	150
T _{stg}	Storage Temperature	°C	-65 to 150

Thermal Resistance^[3]

(V_d = 4.8 V, I_{dd} = 53 mA, T_c = 100° C)
 $\theta_{jc} = 58.6^\circ\text{C/W}$

Notes:

1. Operation of this device in excess of any of these limits may cause permanent damage.
2. Source lead temperature is 25° C. Derate 17 mW/°C for T_c > 118° C.
3. Thermal resistance measured using 150° C Infra-Red Microscopy Technique.

Electrical Specifications

T_A = 25° C, V_{dd1} = V_{dd2} = 4.8 V, V_{sd1} = V_{sd2} = 0 V at R_{bias} = 1.5 kohm, RF performance at 900 MHz, CW operation unless otherwise stated.

Symbol	Parameter and Test Condition	Units	Min.	Typ.	Max.
V _{dd}	Supply Voltage	V		4.8	
I _{dd}	Total Supply Current per amplifier (I _{dq} +I _{bias})	mA	48	60.9	72
Gain	Gain	dB	17.2	18.4	19.4
NF ^[1]	Noise Figure	dB		0.27	0.45
OP1dB	Output Power at 1dB Gain Compression	dBm		21.2	
IIP3 ^[2]	Input Third Order Intercept Point	dBm	17	19.1	
S11	Input Return Loss, 50 Ω source	dB		-10.9	
S22	Output Return Loss, 50 Ω load	dB		-17.5	
S12	Reverse Isolation	dB		-22.4	
S31	Isolation between R _{Fin1} and R _{Fin2}	dB		-36.8	
V _{sd1,2} ^[3]	Maximum shutdown voltage required to turn ON LNA	V		0.5	
V _{sd1,2} ^[3]	Minimum shutdown voltage required to turn OFF LNA	V		1.6	
I _{dq} ^[4]	Current at V _{dd} with V _{sd} = 0 V	mA		58.6	
	Current at V _{dd} with V _{sd} = 3 V	mA		0.01	
I _{sd} ^[4]	Current at V _{sd} with V _{sd} = 0 V	μA		4	
	Current at V _{sd} with V _{sd} = 3 V	μA		220	
I _{bias} ^[4]	Current at V _{bias} with V _{sd} = 0 V	mA		2.3	
	Current at V _{bias} with V _{sd} = 3 V	mA		1.61	

Notes:

1. Noise figure at the DUT RF Input pin, board losses are deembedded.
2. IIP3 test condition: FRF1-FRF2 = 1 MHz with input power of -20 dBm per tone.
3. V_{sd1} and V_{sd2} are active LOW.
4. Refer to Figure 6 for more details.

Product Consistency Distribution Charts

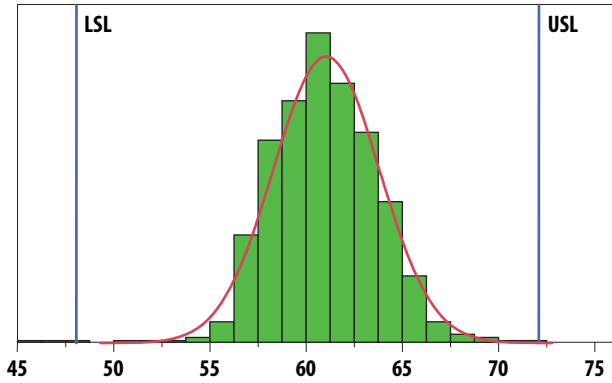

Figure 1. Idd, LSL = 48 mA, nominal = 60.9 mA, USL = 72 mA

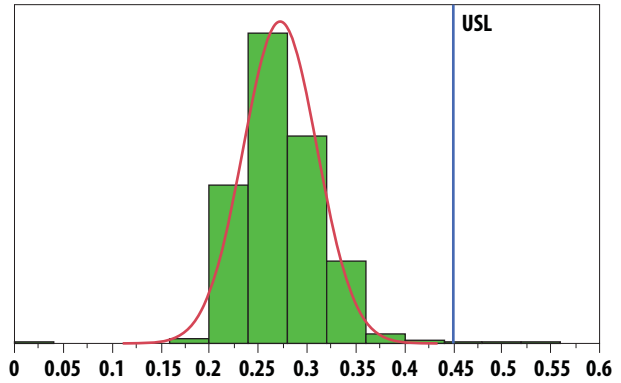

Figure 2. NF, nominal = 0.27 dB, USL = 0.45 dB

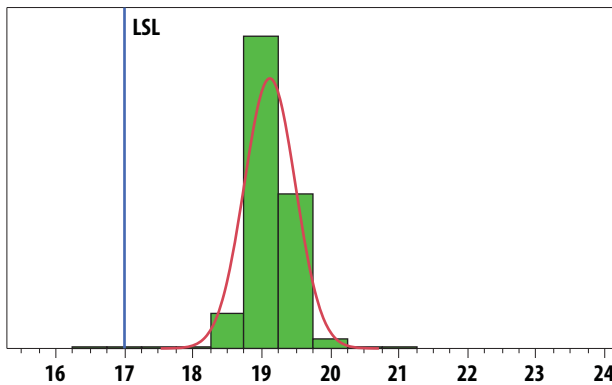

Figure 3. IIP3, LSL = 17 dBm, nominal = 19.1 dBm

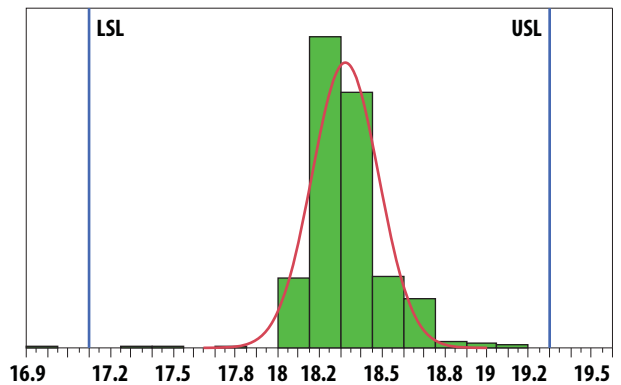

Figure 4. Gain, LSL = 17.2 dB, nominal = 18.4 dB, USL = 19.4 dB

Notes:

1. Distribution data sample size is 6500 samples taken from 12 different wafer lots. Future wafers allocated to this product may have nominal values anywhere between the upper and lower limits.
2. Circuit trace losses for NF have been de-embedded from measurements above.

Demo Board Layout

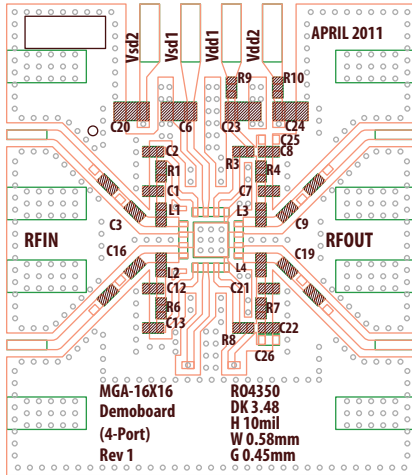

Figure 5. Demo Board Layout Diagram

Demo Board Schematic

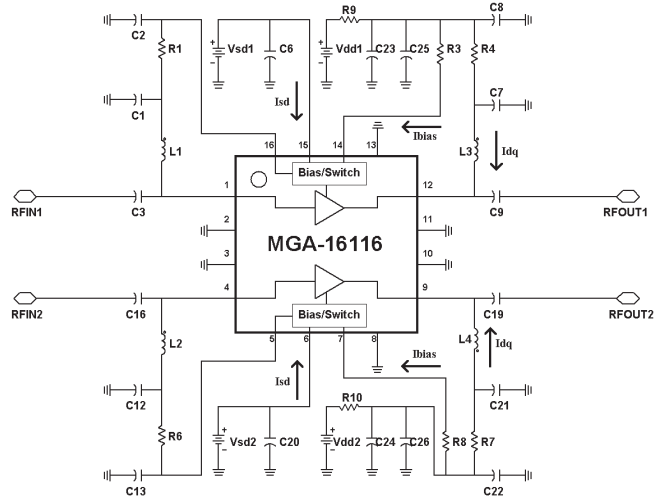

Figure 6. Demo Board Schematic Diagram

Notes:

1. Recommended PCB material is 10 mils Rogers RO4350.
2. Suggested component values may vary according to layout and PCB material.
3. Board loss at 900 MHz is 0.056 dB
4. The schematic is shown with the assumption that similar PCB is used for all MGA-16116, MGA-16216 and MGA-16316.
5. Detail of the components needed for this product is shown in Table 1.
6. R1 and R6 are for low frequency stability.
7. Bias to each LNA is adjustable using R3 and R8 (see Figure 6). Increasing R3 and R8 will reduce bias current (Idd) and vice-versa.
8. R9/R10 are stability improvement resistors that may not be needed in actual application. They are included in the demoboard to provide isolation from power supply noise.
9. Center Paddle is grounded.

Table 1. Component list for 900 MHz matching

PART	Size	Value	Detail Part Number
C1, C12	0402	20 pF	GJM1555C1H200GB01
C2, C13, C8, C22	0402	0.1 μ F	GRM155R71C104KA88D
C3, C9, C16, C19	0402	100 pF	GRM1555C1H101JD01E
C6, C20, C23, C34	0805	4.7 μ F	GRM21BR60J475KA11L
C7, C21	0402	12 pF	GJM1555C1H120GB01
C25, C26	0402	NOT USED	-
L1, L2	0402	68 nH	LQW15AN68NG00
L3, L4	0402	120 nH	LQW15ANR12J00
R1, R6	0402	51 ohm	RK73B1ETTP510J
R3, R8	0402	1.5 kohm	RK73B1ELTP152J
R4, R7	0402	0 ohm	RK73B1ETTP0R0J
R9, R10	0402	10 ohm	RK73B1ETTP100J

Table 2. Below is the table showing the MGA-16116 Reflection Coefficient Parameters tuned for Maximum OIP3, Vdd = 4.8 V, Idd = 35 mA per amplifier. Input gamma is tuned for Fmin. The reflection coefficients are for single amplifier.

Frequency (MHz)	Gamma Load Position		IIP3 (dBm)	Gain (dB)
	Magnitude	Angle		
450	0.51	44.1	17.38	20.02
700	0.643	34.9	22.09	16.8
835	0.643	46.5	25.18	15.1
950	0.386	40.0	23.20	16.62
1450	0.514	86.4	25.77	14.39

Table 3. Below is the table showing the MGA-16116 Reflection Coefficient Parameters tuned for Maximum OIP3, Vdd = 4.8 V, Idd = 60 mA per amplifier. Input gamma is tuned for Fmin. The reflection coefficients are for single amplifier.

Frequency (MHz)	Gamma Load Position		IIP3 (dBm)	Gain (dB)
	Magnitude	Angle		
450	0.514	43.2	21.32	20.34
700	0.39	40.5	23.15	18.6
835	0.515	57.6	26.90	16.1
950	0.386	20.0	26.71	16.31
1450	0.643	92.9	29.83	13.98

Table 4. Below is the table showing the MGA-16116 Reflection Coefficient Parameters tuned for Maximum OIP3, Vdd = 4.8 V, Idd = 75 mA per amplifier. Input gamma is tuned for Fmin. The reflection coefficients are for single amplifier.

Frequency (MHz)	Gamma Load Position		IIP3 (dBm)	Gain (dB)
	Magnitude	Angle		
450	0.128	59.8	21.07	22.75
700	0.257	30.1	24.33	19.16
835	0.257	149.9	23.80	18.46
950	0.128	180	24.74	17.98
1450	0.257	29.9	28.73	15.03

Notes:

1. IIP3 test condition: FRF1-FRF2 = 1 MHz with input power of -20 dBm per tone.
2. Idd can be obtained by varying the Vg1/Vg2. Refer to figure 7.

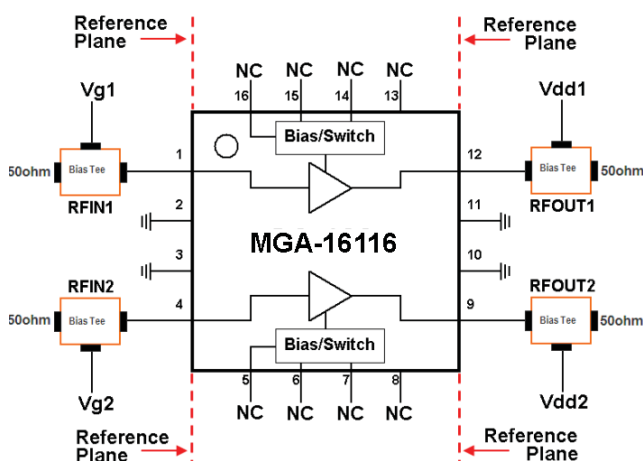

Notes:

1. Maximum OIP3 is measured on coplanar waveguide made on 0.010 inch thick ROGER 4350.

Figure 7. RFininput and RFOutput Reference Plane

Typical 900 MHz RF Performance Plots

RF performance at $T_A = 25^\circ\text{C}$, $V_{dd} = 4.8\text{ V}$, $I_{dd} = 60\text{ mA}$. Measurements made on single-ended amplifier in LNA mode tuned to 900 MHz, using Figure 5 demoboard and Figure 6 circuit. Signal = CW unless stated otherwise. IIP3 test condition: FRF1-FRF2 = 1 MHz with input power of -20 dBm per tone.

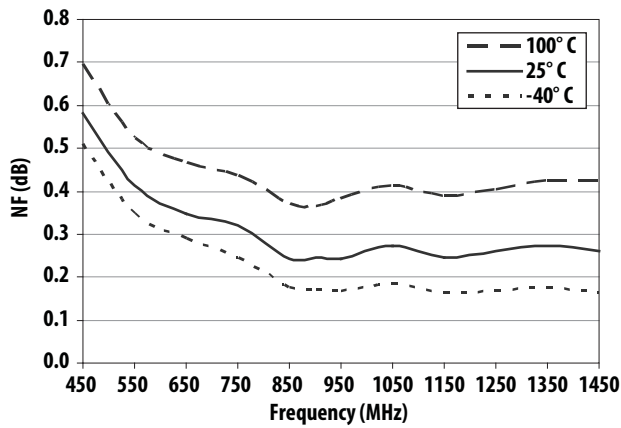

Figure 8. NF vs Frequency vs Temperature [1]

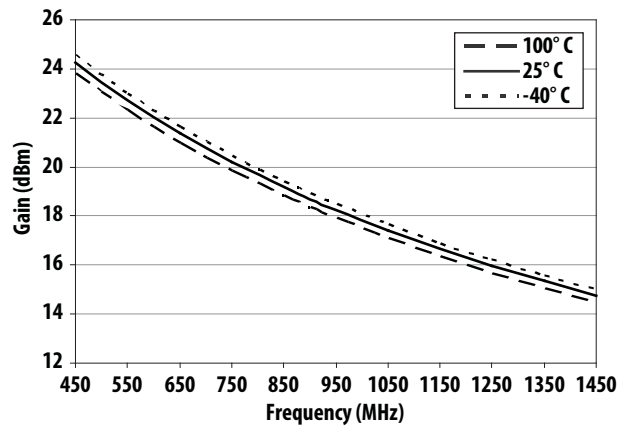

Figure 9. Gain vs Frequency vs Temperature

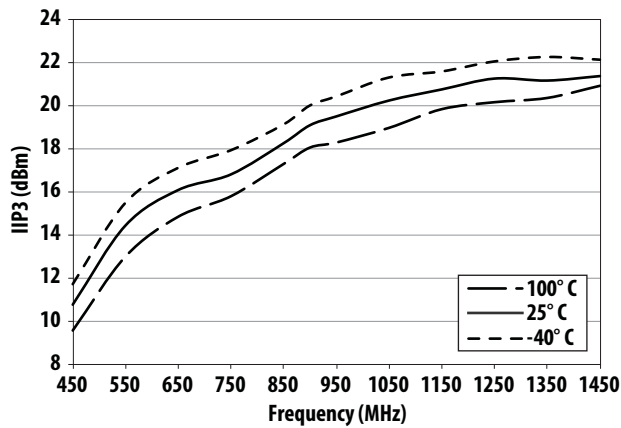

Figure 10. IIP3 vs Frequency vs Temperature

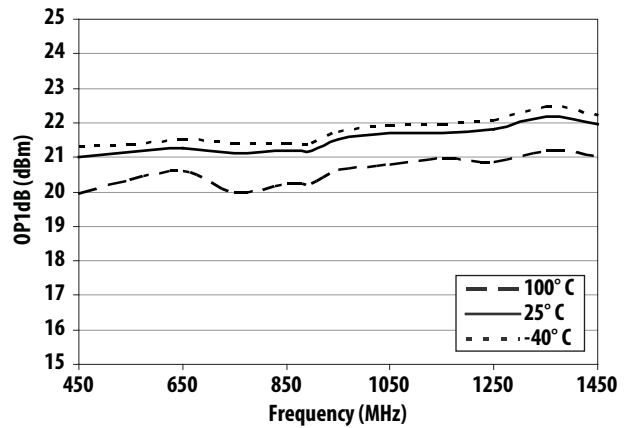

Figure 11. OP1dB vs Frequency vs Temperature

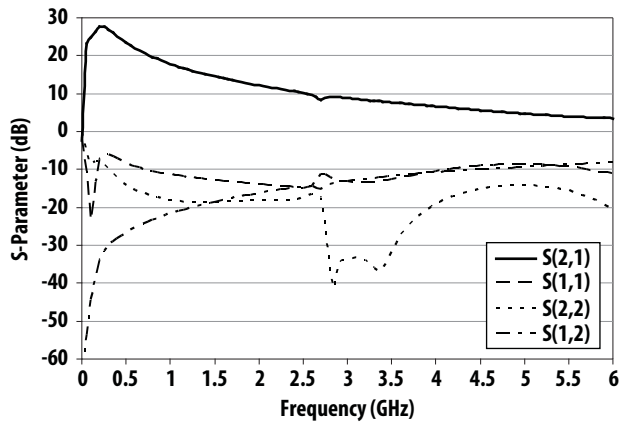

Figure 12. Input Return Loss, Output Return Loss, Gain, Reverse Isolation vs Frequency

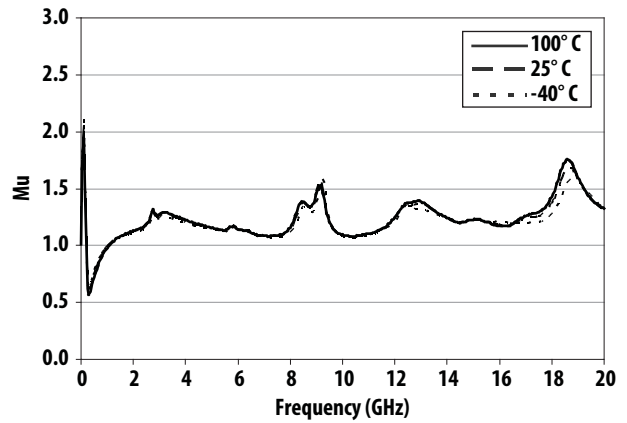

Figure 13. Mu stability factors vs Frequency vs Temperature

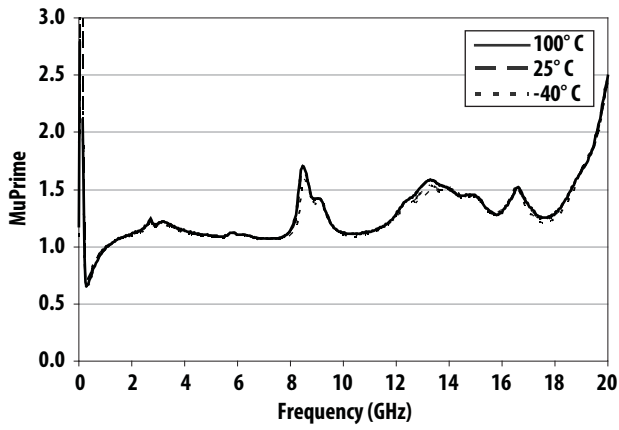

Figure 14. Mu' stability factors vs Frequency vs Temperature

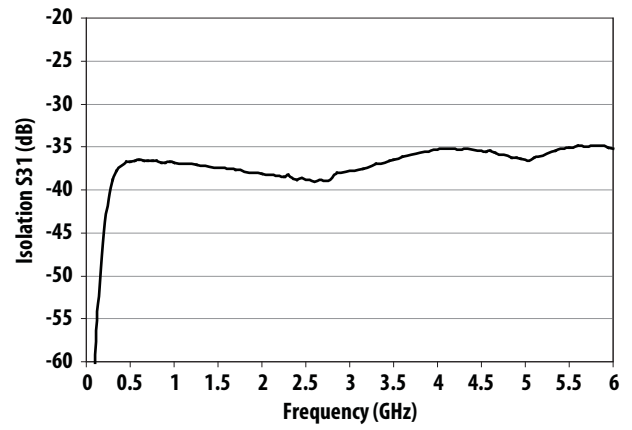

Figure 15. Input Ports Isolation (S31) vs Frequency

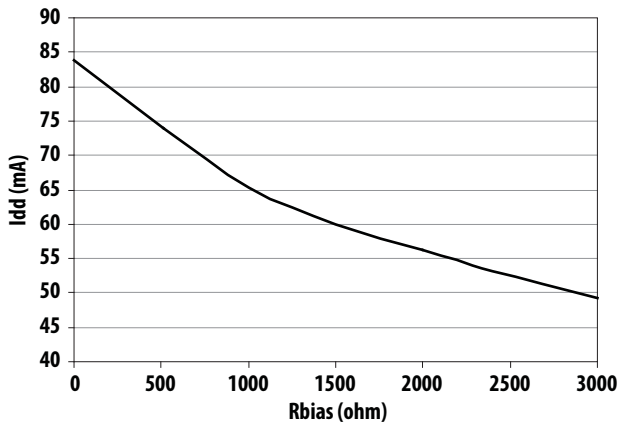

Figure 16. Idd vs Rbias [2]

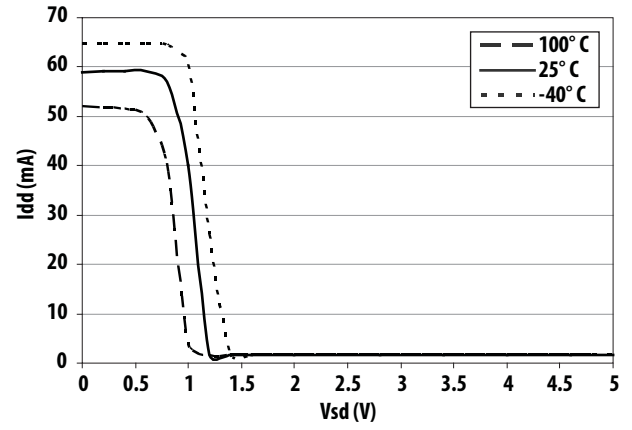

Figure 17. Idd vs Vsd

Notes:

1. Circuit trace losses for NF have been de-embedded from measurements above.
2. Rbias is R3 and R8 from Figure 6.

Table 5. Typical Scattering Parameters, Vdd = 4.8 V, Idd = 35 mA

LNA SPAR (100 MHz – 20 GHz) The S-parameter are for single amplifier.

Freq	S11	S11	S21	S21	S12	S12	S22	S22
(GHz)	(dB)	(ang)	(dB)	(ang)	(dB)	(ang)	(dB)	(ang)
0.1	-1.022	-28.498	29.161	154.654	-37.965	79.027	-7.090	-19.544
0.5	-6.649	-94.870	22.772	104.259	-26.459	66.399	-13.896	-50.600
0.7	-8.297	-112.042	20.318	93.331	-24.049	64.475	-15.882	-53.370
0.9	-9.364	-125.539	18.444	84.974	-22.211	62.286	-17.478	-54.610
1.0	-9.758	-130.241	17.596	81.438	-21.400	61.255	-17.917	-53.566
1.5	-10.971	-151.257	14.416	66.113	-18.221	54.575	-20.357	-53.259
1.7	-11.091	-159.069	13.414	60.566	-17.239	51.394	-21.981	-58.813
1.9	-11.104	-166.151	12.539	55.320	-16.328	48.319	-23.407	-64.718
2.0	-11.117	-169.353	12.131	52.718	-15.905	46.647	-23.978	-68.957
2.5	-11.087	177.265	10.360	40.267	-14.104	38.400	-26.564	-97.344
3.0	-11.081	165.669	8.951	28.433	-12.604	29.781	-27.136	-132.391
3.5	-11.096	154.720	7.826	16.983	-11.325	21.025	-25.584	-162.526
4.0	-11.006	142.943	6.892	5.622	-10.213	12.016	-23.963	170.627
4.5	-10.720	129.982	6.100	-5.563	-9.244	2.746	-21.945	142.320
5.0	-10.073	118.799	5.351	-16.665	-8.445	-6.661	-19.977	114.528
5.5	-9.286	106.890	4.697	-27.610	-7.735	-16.237	-17.197	88.526
6.0	-8.439	94.245	4.087	-38.486	-7.175	-26.218	-14.231	70.377
7.0	-7.649	72.483	2.997	-58.517	-6.183	-44.375	-10.813	52.241
8.0	-9.206	56.581	2.362	-77.126	-5.224	-62.113	-10.533	46.694
9.0	-11.853	31.257	1.930	-96.806	-4.263	-81.118	-10.307	43.266
10.0	-11.268	-4.194	1.289	-117.528	-3.757	-101.712	-8.627	20.267
11.0	-10.277	-26.164	0.324	-136.898	-3.704	-120.862	-7.062	-2.650
12.0	-11.155	-52.090	-0.159	-153.598	-3.353	-139.372	-6.702	-18.056
13.0	-20.494	-61.926	-0.820	-168.479	-3.505	-153.688	-6.926	-14.524
14.0	-22.385	-159.458	-0.683	171.235	-2.651	-176.492	-6.999	-18.503
15.0	-14.569	127.065	-0.727	147.438	-2.279	158.611	-7.115	-26.831
16.0	-12.363	64.821	-1.734	115.001	-2.934	125.555	-5.770	-43.836
17.0	-7.890	-127.305	-6.052	131.616	-6.607	139.045	-2.049	-74.412
18.0	-12.876	-10.894	-5.846	90.393	-6.352	97.052	-2.285	-68.870
19.0	-7.087	108.141	-4.538	103.243	-4.669	108.441	-3.339	-89.195
20.0	-4.516	31.361	-4.779	55.113	-5.022	58.513	-4.579	-112.660

Table 6. Typical Noise Parameters, for single amplifier, Vdd = 4.8 V, Idd = 35 mA

Freq	Fmin	Γ_{opt}	Γ_{opt}	$R_{n/50}$
GHz	dB	Mag.	Ang.	
450	0.31	0.570	-15.8	0.039
700	0.23	0.442	4.9	0.035
835	0.21	0.426	25.7	0.034
950	0.23	0.392	34.6	0.035
1450	0.4	0.210	86.0	0.037

Notes:

1. The Fmin values are based on noise figure measurements at multiple input impedances using Focus source pull test system. From these measurements a true Fmin is calculated.
2. Scattering and noise parameters are measured on coplanar waveguide made on 0.010 inch thick ROGER 4350. The input reference plane is at the end of the RFinpin and the output reference plane is at the end of the RFoutpin as shown in Figure 7.
3. Idd can be obtained by varying the Vg1/Vg2. Refer to figure 7.

Table 7. Typical Scattering Parameters, Vdd = 4.8 V, Idd = 60 mA

LNA SPAR (100 MHz – 20 GHz) The S-parameter are for single amplifier.

Freq (GHz)	S11 (dB)	S11 (ang)	S21 (dB)	S21 (ang)	S12 (dB)	S12 (ang)	S22 (dB)	S22 (ang)
0.1	-1.074	-31.307	30.372	152.301	-38.598	79.819	-8.582	-20.776
0.5	-7.419	-99.051	23.126	101.761	-26.683	69.129	-15.871	-48.167
0.7	-9.041	-115.776	20.596	91.484	-24.165	66.973	-17.771	-49.366
0.9	-10.023	-128.775	18.669	83.583	-22.241	64.407	-19.273	-49.337
1.0	-10.399	-133.219	17.812	80.178	-21.408	63.192	-19.593	-47.750
1.5	-11.500	-153.458	14.600	65.392	-18.141	55.849	-21.764	-45.214
1.7	-11.572	-161.056	13.591	60.010	-17.142	52.498	-23.571	-49.907
1.9	-11.538	-167.985	12.711	54.875	-16.230	49.228	-25.238	-55.033
2.0	-11.537	-171.125	12.302	52.304	-15.809	47.475	-25.944	-59.265
2.5	-11.445	175.803	10.521	40.088	-13.992	38.931	-29.570	-90.923
3.0	-11.401	164.403	9.105	28.417	-12.490	30.048	-30.232	-135.945
3.5	-11.399	153.594	7.971	17.073	-11.217	21.106	-27.571	-170.069
4.0	-11.292	141.943	7.028	5.853	-10.123	11.945	-25.227	162.620
4.5	-10.974	129.027	6.226	-5.240	-9.162	2.551	-22.592	135.000
5.0	-10.296	117.928	5.475	-16.254	-8.374	-6.976	-20.256	108.170
5.5	-9.477	106.083	4.815	-27.119	-7.680	-16.555	-17.261	83.874
6.0	-8.603	93.478	4.202	-37.909	-7.123	-26.573	-14.249	67.156
7.0	-7.784	71.674	3.114	-57.850	-6.153	-44.852	-10.893	50.129
8.0	-9.391	55.504	2.483	-76.469	-5.211	-62.621	-10.730	45.175
9.0	-12.116	29.799	2.048	-96.207	-4.265	-81.667	-10.574	42.707
10	-11.471	-5.874	1.407	-116.940	-3.779	-102.196	-8.835	20.126
11	-10.440	-27.549	0.451	-136.443	-3.736	-121.324	-7.217	-2.639
12	-11.273	-53.811	-0.038	-153.270	-3.384	-139.868	-6.823	-17.959
13	-20.959	-65.754	-0.721	-168.292	-3.563	-154.175	-7.004	-13.899
14	-22.024	-163.703	-0.599	171.370	-2.714	-176.815	-7.040	-17.790
15	-14.309	126.539	-0.665	147.554	-2.345	158.380	-7.104	-26.156
16	-12.226	65.090	-1.681	115.096	-3.019	125.379	-5.734	-43.382
17	-7.911	-127.772	-6.012	131.726	-6.652	139.053	-2.042	-74.188
18	-12.992	-10.792	-5.844	90.462	-6.431	96.994	-2.257	-68.762
19	-7.042	108.026	-4.522	103.345	-4.710	108.465	-3.313	-89.050
20	-4.476	31.259	-4.758	55.261	-5.060	58.580	-4.528	-112.266

Table 8. Typical Noise Parameters, for single amplifier, Vdd = 4.8 V, Idd = 60 mA

Freq GHz	Fmin dB	Γ_{opt} Mag.	Γ_{opt} Ang.	$R_{n/50}$
450	0.31	0.557	-17.0	0.035
700	0.23	0.438	0.5	0.033
835	0.21	0.460	21.6	0.032
950	0.23	0.423	33.1	0.032
1450	0.42	0.172	92.7	0.036

Notes:

1. The Fmin values are based on noise figure measurements at multiple input impedances using Focus source pull test system. From these measurements a true Fmin is calculated.
2. Scattering and noise parameters are measured on coplanar waveguide made on 0.010 inch thick ROGER 4350. The input reference plane is at the end of the RFinpin and the output reference plane is at the end of the RFoutpin as shown in Figure 7.
3. Idd can be obtained by varying the Vg1/Vg2. Refer to figure 7.

Table 9. Typical Scattering Parameters, Vdd = 4.8 V, Idd = 75 mA

LNA SPAR (100 MHz – 20 GHz) The S-parameter are for single amplifier.

Freq (GHz)	S11 (dB)	S11 (ang)	S21 (dB)	S21 (ang)	S12 (dB)	S12 (ang)	S22 (dB)	S22 (ang)
0.1	-1.313	-33.530	31.014	150.648	-38.589	82.014	-9.661	-21.676
0.5	-7.873	-101.259	23.314	100.420	-26.803	70.767	-17.048	-45.449
0.7	-9.472	-117.752	20.741	90.485	-24.212	68.268	-18.831	-45.680
0.9	-10.402	-130.466	18.790	82.841	-22.239	65.516	-20.230	-44.960
1.0	-10.777	-134.737	17.925	79.542	-21.407	64.225	-20.421	-43.253
1.5	-11.805	-154.527	14.699	65.015	-18.111	56.520	-22.336	-39.860
1.7	-11.852	-162.032	13.689	59.715	-17.106	53.063	-24.200	-43.748
1.9	-11.792	-168.879	12.807	54.640	-16.185	49.733	-25.976	-48.172
2.0	-11.784	-171.996	12.394	52.113	-15.760	47.932	-26.759	-52.109
2.5	-11.656	175.184	10.608	40.041	-13.941	39.243	-31.149	-84.360
3.0	-11.594	163.899	9.189	28.441	-12.442	30.253	-32.084	-136.841
3.5	-11.581	153.195	8.048	17.188	-11.174	21.216	-28.646	-173.768
4.0	-11.462	141.576	7.102	6.023	-10.080	11.962	-25.816	158.924
4.5	-11.124	128.688	6.296	-5.029	-9.126	2.544	-22.900	131.803
5.0	-10.429	117.634	5.542	-15.972	-8.341	-7.041	-20.389	105.521
5.5	-9.589	105.823	4.879	-26.805	-7.655	-16.664	-17.298	81.989
6.0	-8.686	93.240	4.265	-37.559	-7.099	-26.672	-14.261	65.816
7.0	-7.862	71.395	3.176	-57.450	-6.142	-44.949	-10.940	49.294
8.0	-9.495	55.210	2.549	-76.083	-5.204	-62.770	-10.846	44.633
9.0	-12.268	29.175	2.104	-95.838	-4.274	-81.847	-10.697	42.499
10.0	-11.584	-6.517	1.463	-116.574	-3.791	-102.332	-8.928	20.087
11.0	-10.522	-28.153	0.508	-136.137	-3.751	-121.438	-7.284	-2.588
12.0	-11.357	-54.514	0.015	-153.014	-3.401	-139.971	-6.889	-17.777
13.0	-21.178	-67.548	-0.677	-168.073	-3.589	-154.248	-7.059	-13.574
14.0	-21.655	-166.052	-0.566	171.616	-2.742	-176.860	-7.048	-17.396
15.0	-14.145	126.771	-0.631	147.729	-2.383	158.332	-7.099	-25.793
16.0	-12.117	65.327	-1.666	115.223	-3.062	125.393	-5.710	-43.125
17.0	-7.916	-127.952	-5.980	131.954	-6.667	139.243	-2.048	-74.067
18.0	-13.009	-9.966	-5.842	90.681	-6.475	97.145	-2.253	-68.631
19.0	-6.983	107.757	-4.520	103.388	-4.751	108.605	-3.313	-88.879
20.0	-4.463	31.666	-4.751	55.507	-5.083	58.833	-4.500	-112.076

Table 10. Typical Noise Parameters, for single amplifier, Vdd = 4.8 V, Idd = 75 mA

Freq GHz	Fmin dB	Γ_{opt} Mag.	Γ_{opt} Ang.	$R_{n/50}$
450	0.32	0.521	-18.1	0.036
700	0.23	0.426	-6.4	0.033
835	0.23	0.387	17.8	0.033
950	0.25	0.388	25.5	0.033
1450	0.43	0.139	93.9	0.037

Notes:

1. The Fmin values are based on noise figure measurements at multiple input impedances using Focus source pull test system. From these measurements a true Fmin is calculated.
2. Scattering and noise parameters are measured on coplanar waveguide made on 0.010 inch thick ROGER 4350. The input reference plane is at the end of the RFinpin and the output reference plane is at the end of the RFoutpin as shown in Figure 7.
3. Idd can be obtained by varying the Vg1/Vg2. Refer to figure 7.

BALANCED MODE APPLICATION

Electrical Specifications

$T_A = 25^\circ \text{C}$, $V_{dd1} = V_{dd2} = 4.8 \text{V}$, $I_{dd1} = I_{dd2} = 60 \text{mA}$ at $R_{bias} = 1.5 \text{k}\Omega$, RF performance at 900 MHz, CW operation unless otherwise stated.

Symbol	Parameter and Test Condition	Units	Typ.
Vdd	Supply Voltage per amplifier	V	4.8
Idd	Supply Current per amplifier	mA	60
Gain	Gain	dB	18.2
NF	Noise Figure	dB	0.37
OP1dB	Output Power at 1dB Gain Compression	dBm	23.9
IIP3	Input Third Order Intercept Point	dBm	21.6
S11	Input Return Loss, 50 Ω source	dB	-24.1
S22	Output Return Loss, 50 Ω load	dB	-34.7
S12	Reverse Isolation	dB	-23.1

Balanced Amplifier Demo Board Layout

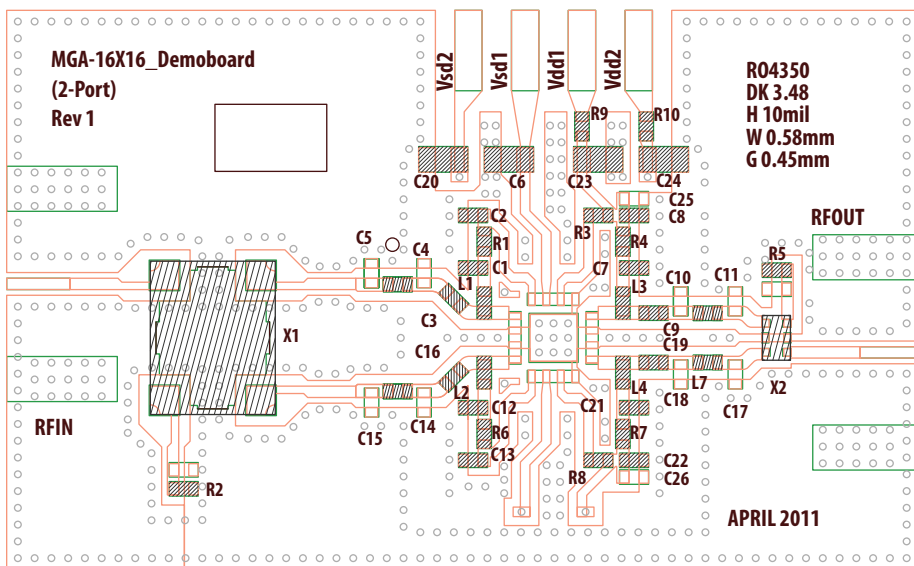

Figure 18. Balanced Amplifier Demo Board Layout Diagram

Notes:

1. Recommended PCB material is 10 mils Rogers RO4350.
2. Suggested component values may vary according to layout and PCB material.
3. Board loss at 900 MHz is 0.133 dB.

Balanced Amplifier Demo Board Schematic

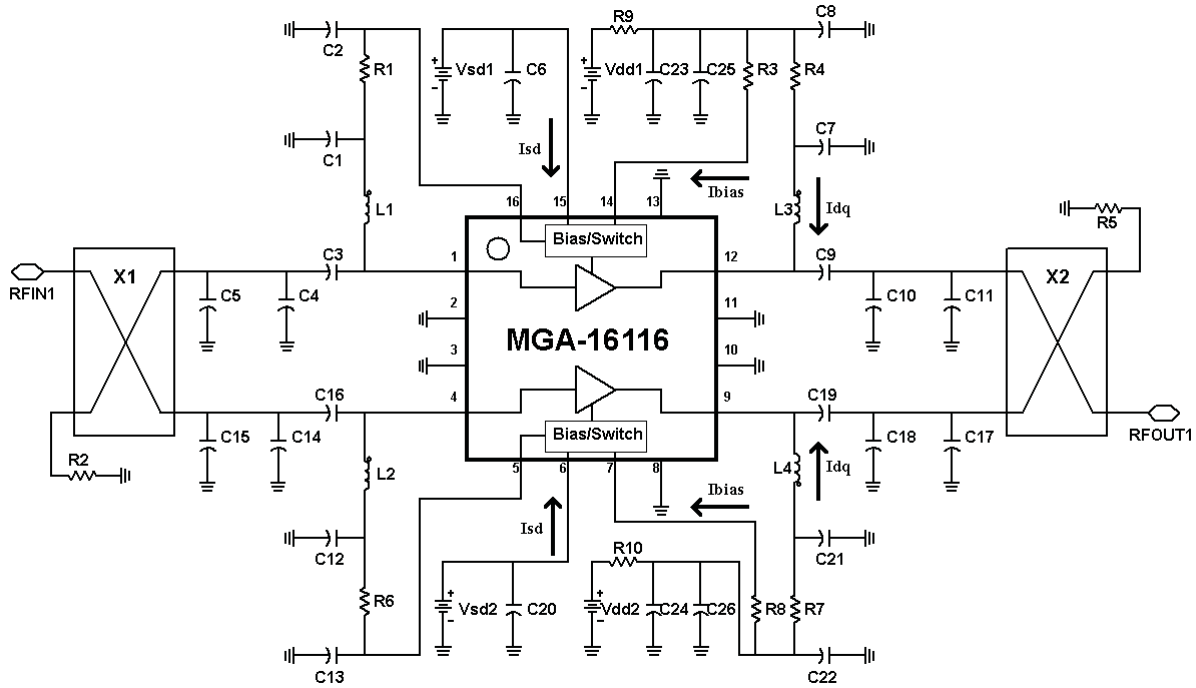

Figure 19. Balanced Amplifier Demo Board Schematic.

Table 11. Component list for 900 MHz matching

PART	Size	Value	Detail Part Number
C1, C12	0402	20 pF	GJM1555C1H200GB01
C2, C8, C13, C22	0402	0.1 μ F	GRM155R71C104KA88D
C3, C9, C16, C19	0402	100 pF	GRM1555C1H101JD01E
C6, C20, C23, C34	0805	4.7 μ F	GRM21BR60J475KA11L
C7, C21	0402	12 pF	GJM1555C1H120GB01
C4, C5, C10, C11, C14, C15, C17, C18, C25, C26	0402	NOT USED	
L1, L2	0402	68 nH	LQW15AN68NG00
L3, L4	0402	120 nH	LQW15ANR12J00
R1, R6	0402	51 ohm	RK73B1ETTP510J
R3, R8	0402	1.5 kohm	RK73B1ELTP152J
R4, R7	0402	0 ohm	RK73B1ETTP0R0J
R9, R10	0402	10 ohm	RK73B1ETTP100J
R2, R5	0402	51 ohm	RK73B1ETTP510J
X1	-	-	X3C09P1-03S
X2	-	-	C0810J5003AHF

Typical 900 MHz RF Performance Plots on Balanced Mode

RF performance at $T_A = 25^\circ\text{C}$, $V_{dd1} = V_{dd2} = 4.8\text{V}$, $I_{dd1} = I_{dd2} = 60\text{mA}$, LNA mode, measured on demo board in Figure 18. Signal is CW unless stated otherwise. Application Test Circuit is shown in Figure 19 and Table 11. IIP3 test condition: FRF1-FRF2 = 1MHz with input power of -20 dBm per tone.

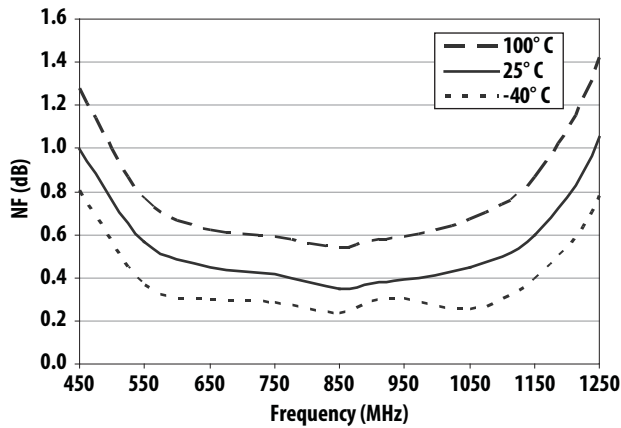

Figure 20. NF vs Frequency vs Temperature^[1]

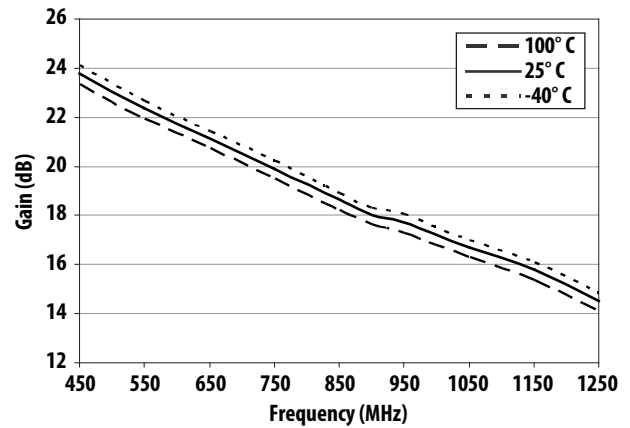

Figure 21. Gain vs Frequency vs Temperature

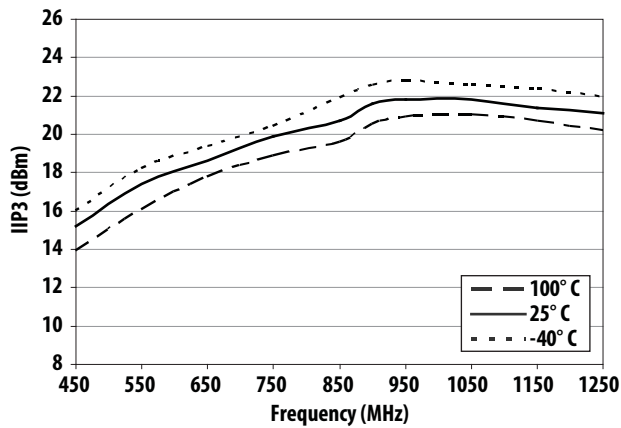

Figure 22. IIP3 vs Frequency vs Temperature

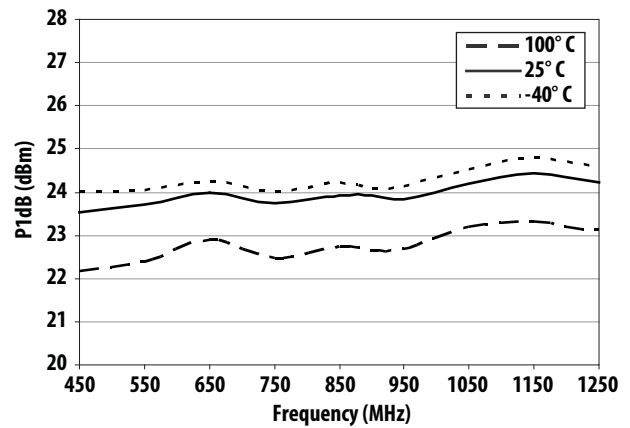

Figure 23. OP1dB vs Frequency vs Temperature

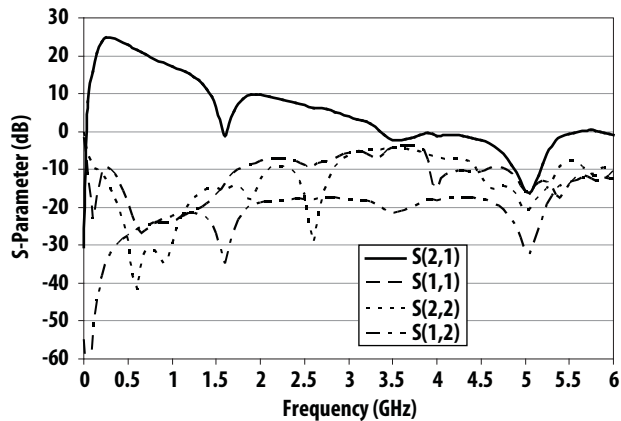

Figure 24. Input Return Loss, Output Return Loss, Gain, Reverse Isolation vs Frequency

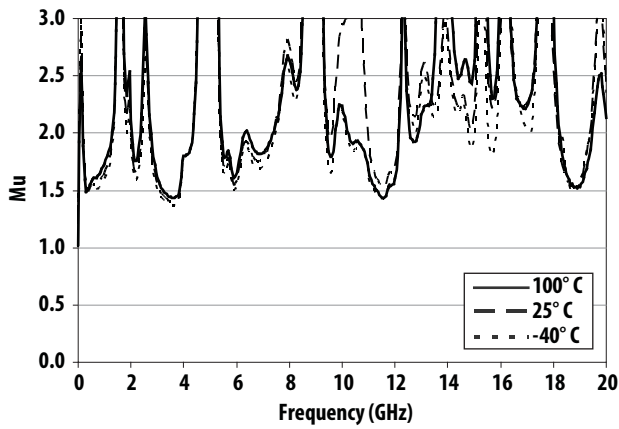

Figure 25. Mu stability factors vs Frequency vs Temperature

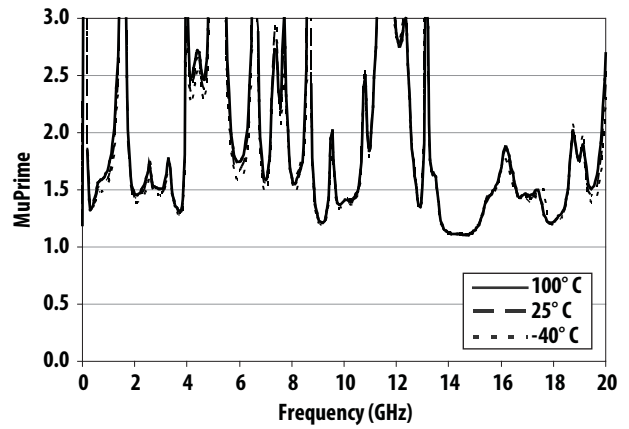

Figure 26. Mu' stability factors vs Frequency vs Temperature

Note:

1. Circuit trace losses for NF have been de-embedded from measurements above.

Part Number Ordering Information

Part Number	No. of Devices	Container
MGA-16116-BLKG	100	Antistatic Bag
MGA-16116-TR1G	1000	7" Reel

Package Dimensions

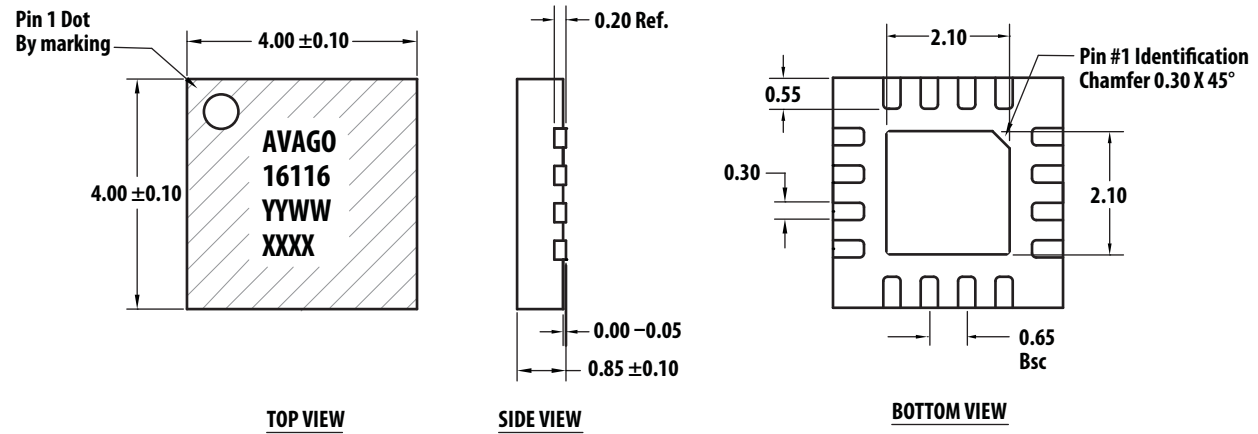

Recommended PCB Land Pattern and Stencil Design

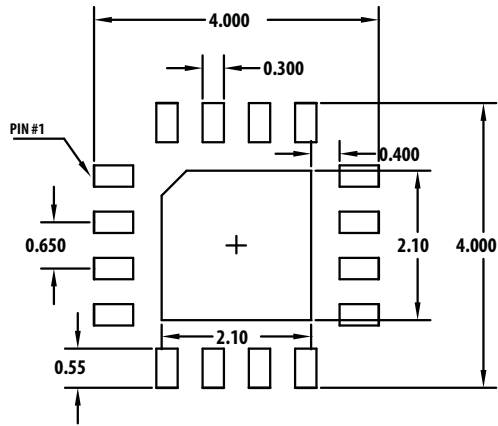

Land Pattern

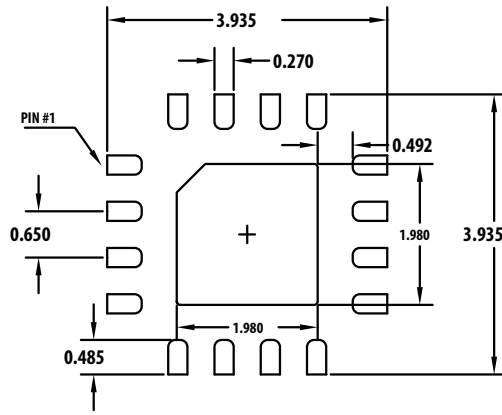

Stencil Opening

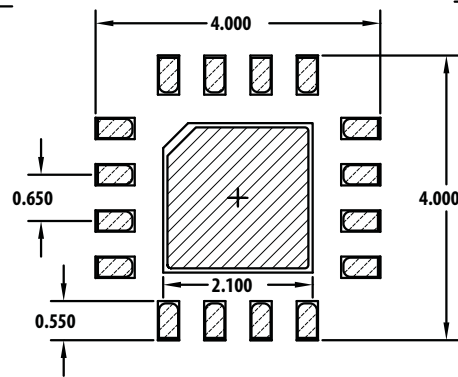

Combination of Land Pattern & Stencil Opening

Note:
 1. ALL DIMENSIONS ARE IN MILLIMETERS
 2. 4mil stencil thickness is recommended

Device Orientation

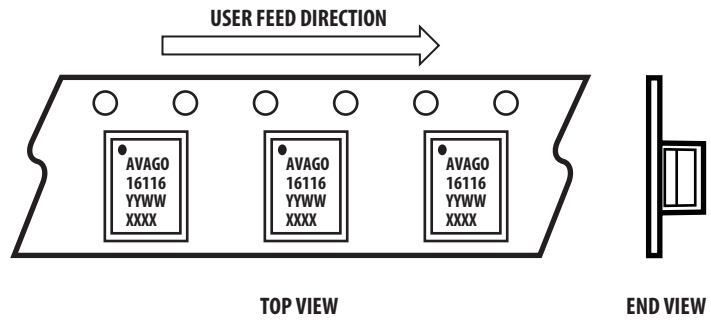
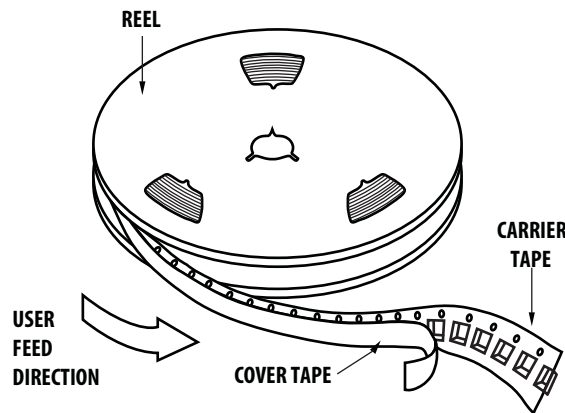

Tape Dimensions

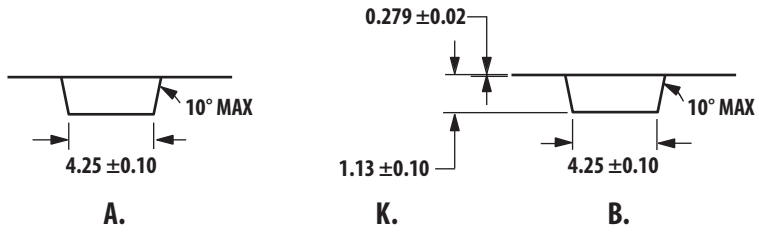
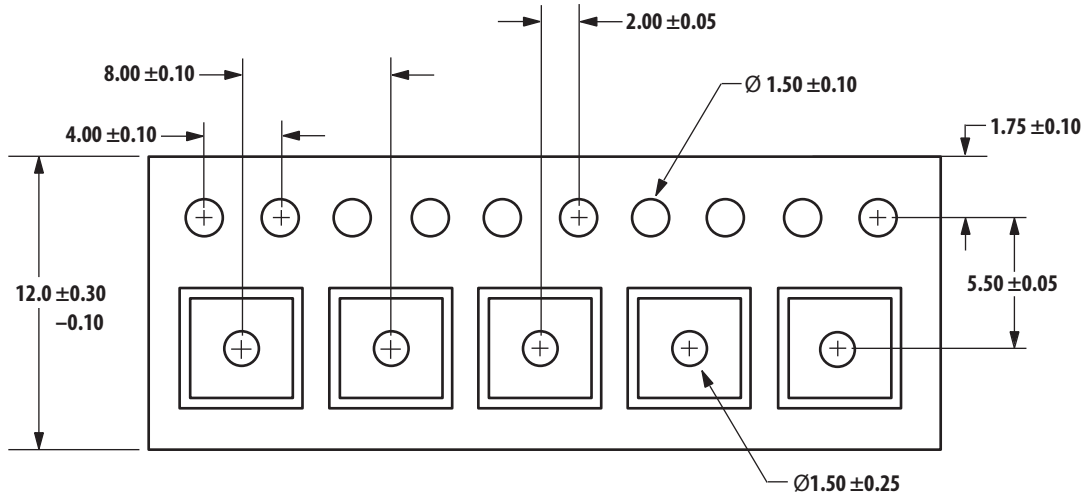

Reel Dimensions – 7 inch

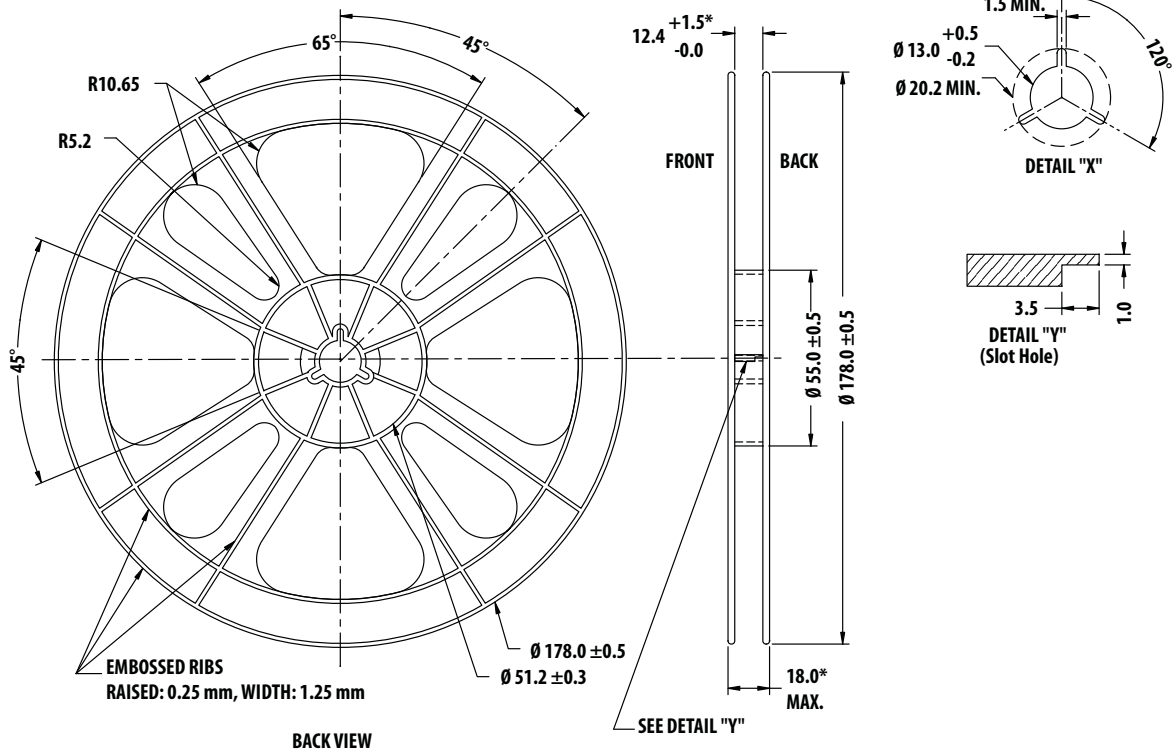
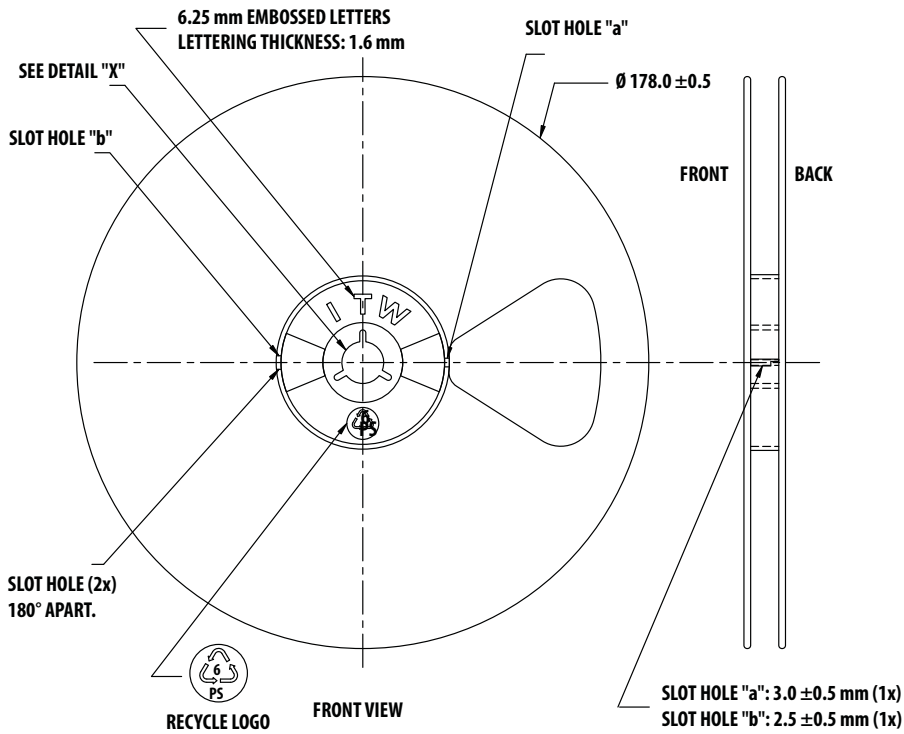

For product information and a complete list of distributors, please go to our web site: www.avagotech.com

Avago, Avago Technologies, and the A logo are trademarks of Avago Technologies in the United States and other countries. Data subject to change. Copyright © 2005-2012 Avago Technologies. All rights reserved. AV02-3721EN - July 24, 2012

