

MGA-310G

GNSS Low Noise amplifier with Variable bias current and shutdown function



Data Sheet

Description

Avago Technologies' MGA-310G is an ultra low-noise amplifier designed for GNSS band applications. The LNA uses Avago Technologies' proprietary GaAs Enhancement-mode pHEMT process to achieve high gain with very low noise figures and high linearity. Noise figure distribution is very tightly controlled. Gain and supply current are guaranteed parameters. A CMOS compatible shutdown pin is included to turn the LNA off and provide variable bias.

The MGA-310G LNA is usable down to 1.8 V operation. It achieves low noise figures and high gain even at 1.8 V, making it suitable for use in critical low power GNSS band applications.

Component Image

Surface Mount (1.13 x 1.1 x 0.5 mm³) 6-lead UQFN

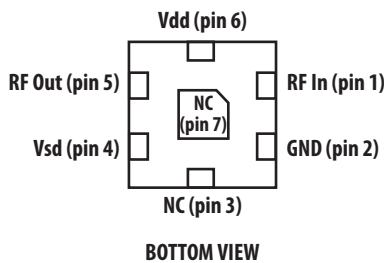
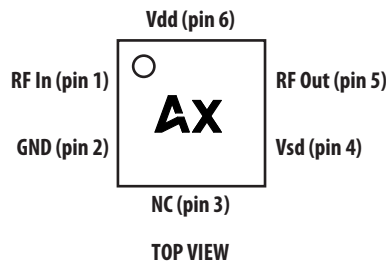

Note:
Package marking provides orientation and identification
"A" = Product code
"X" = Year/month code

Attention: Observe precautions for handling electrostatic sensitive devices.
ESD Machine Model = 50 V
ESD Human Body Model = 250 V
Refer to Avago Application Note A004R: Electrostatic Discharge, Damage and Control.

Features

- Advanced GaAs E-pHEMT
- Low Noise Figure: 0.82 dB typ.
- High Gain: 15.2 dB typ.
- Low external component count
- High IIP3 and IP1dB
- Wide Supply Voltage: 1 V to 3.6 V
- Shutdown current : < 1 μ A
- CMOS compatible shutdown pin (SD)
- Adjustable bias current via single external resistor/voltage
- Small Footprint: (1.13 x 1.1 mm²)
- Low Profile: 0.5 mm typ.
- Meets MSL1, Lead-free and halogen free

Specifications (Targeted Typical performance @ 25° C)

At 1.575 GHz, Vdd = 2.7 V, Idd = 8.0 mA

- Gain = 15.2 dB
- NF = 0.82 dB
- IIP3 = 1.8 dBm
- IP1dB = 2.0 dBm
- S11 = -9.5 dB, S22 = -14 dB

Application

- LNA for GNSS frequency bands

Application Circuit

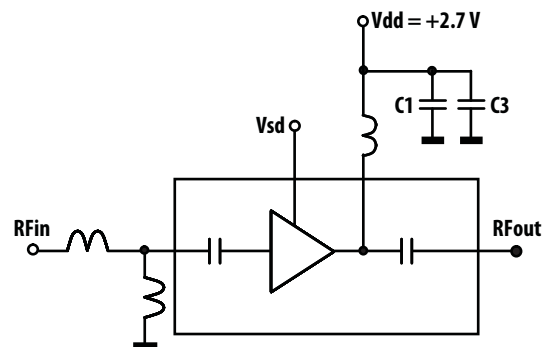

Absolute Maximum Rating ⁽¹⁾ $T_A = 25^\circ\text{C}$

Symbol	Parameter	Units	Absolute Max.
V _{dd}	Device Drain to Source Voltage ⁽²⁾	V	3.6
I _{dd}	Drain Current ⁽²⁾	mA	20
P _{in,max}	CW RF Input Power (V _{dd} = 2.7 V, I _{dd} = 8 mA)	dBm	10
P _{diss}	Total Power Dissipation ⁽⁴⁾	mW	72
T _j	Junction Temperature	°C	150
T _{STG}	Storage Temperature	°C	-65 to 150

Thermal Resistance

Thermal Resistance ⁽³⁾
(V_{dd} = 2.7 V, I_{dd} = 8 mA), $\theta_{j\text{c}} = 120^\circ\text{C/W}$

Notes:

1. Operation of this device in excess of any of these limits may cause permanent damage.
2. Assuming DC quiescent conditions.
3. Thermal resistance measured using Infra-Red measurement technique.
4. Board (module belly) temperature T_B is 25° C. Derate 8.33 mW/°C for T_B > 141° C.

Product Consistency Distribution Charts ^(1,2)

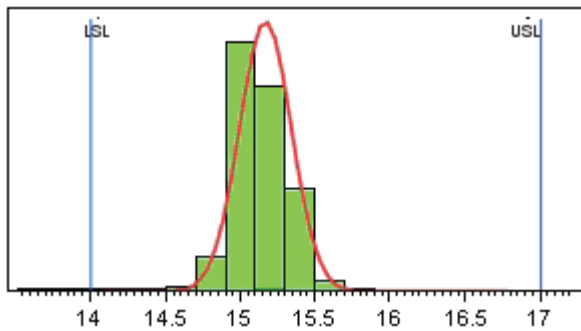

Figure 1. Gain at 1.575 GHz; LSL = 14.0 dB, USL = 17.0, nominal = 15.2 dB

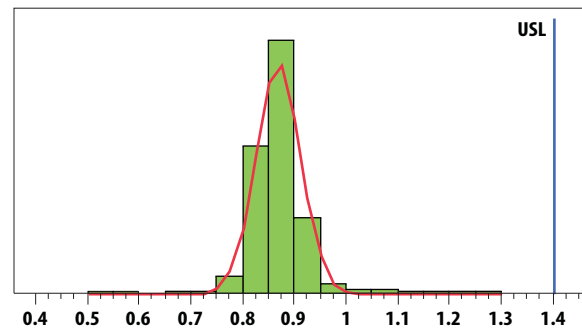

Figure 2. NF at 1.575GHz; USL = 1.4 dB, nominal = 0.87 dB

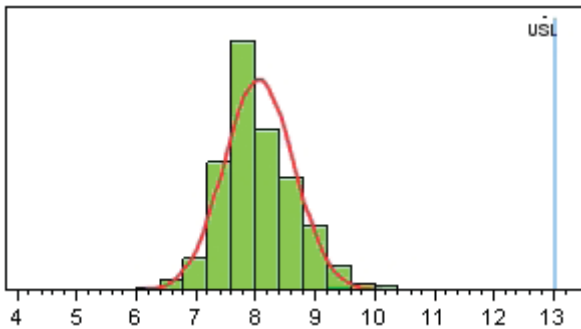

Figure 3. Id at 1.575 GHz; USL = 13 mA, nominal = 8 mA

Notes:

1. Distribution data sample size is 49000 samples taken from 3 LNA wafer. Future wafers allocated to this product may have nominal values anywhere between the upper and lower limits.
2. Measurements are made on a production test board, which represents a trade-off between optimal Gain, NF, IIP3, IP1dB and VSWR. Circuit trace losses have not been de-embedded from actual measurements.

Targeted Electrical Specifications

T_A = 25° C, Freq = 1.575 GHz and 1.6017 GHz, – Typical Performance [1]

Table 1. Performance at V_{dd} = V_{sd} = 2.7 V, I_{dd} = 8 mA (R₁ = 8.2 kOhm) nominal operating conditions

Symbol	Parameter and Test Condition	Units	@1.575 GHz			@1.6017 GHz
			Min.	Typ.	Max.	Typ.
G	Gain	dB	14	15.2	17	15.2
NF [2]	Noise Figure	dB	-	0.87	1.4	0.88
IP1dB	Input 1dB Compressed Power	dBm	-	+2	-	+2.1
IIP3 [3]	Input 3rd Order Intercept Point (2-tone @ Fc +/- 2.5 MHz)	dBm	-	+1.8	-	+2.2
S11	Input Return Loss	dB	-	-9.5	-	-10.5
S22	Output Return Loss	dB	-	-14	-	-15
S12	Reverse Isolation	dB	-	-21	-	-21
IIP2 [4]	Input 2nd Order Intercept Point	dBm	-	15.5	-	-
I _{dd}	Supply DC current at Shutdown (SD) voltage V _{sd} =2.7 V	mA	-	8	13	8
I _{sh}	Shutdown Pin Current	mA	-	0.19	-	0.18
V _{dd}	Supply Voltage	V	-	2.7	-	2.7

Notes:

1. Targeted performance at 1.575 GHz and 1.6017 GHz
2. Circuit losses not deembedded from demoboard. With losses deembedded, NF typical @1.575GHz = 0.82dB, @1.6017GHz = 0.83dB
3. 1.575 GHz IIP3 test condition: F_{RF1} = 1572.5 MHz, F_{RF2} = 1577.5 MHz with input power of -20 dBm per tone measured at the worst case side band
4. OOB Input IP2 test condition: Input jammer tones: 824.6MHz at -17dBm and 2400 MHz at -40dBm. Output IM2 tone at 1575.4 MHz

Table 2. Out-of-band 1dB gain compression performance at V_{dd} = V_{sd} = 2.7 V, I_{dd} = 8 mA (R₁ = 8.2 kOhm) nominal operating conditions

Frequency Band (MHz)	Interferer frequency (MHz)	Gain at interferer frequency (dB)	1dB gain compression level with external interferer frequency, RF Freq = 1575MHz (dBm)	1dB gain compression level with external interferer frequency, RF Freq = 1601.7MHz (dBm)
824 – 849	824	6.5	5.5	6.2
	837	6.5	3.9	4.8
	849	6.6	7.6	8.4
880 - 915	880	6.8	5.7	6.7
	890	6.9	7.9	8.3
	915	6.9	6.9	7
1710 - 1785	1710	14.6	0.2	-1.6
	1748	14.6	0.3	-2
	1785	13.8	0.8	-1.4
1850 - 1910	1850	12.9	1.8	0.1
	1885	12.4	2.6	0.2
	1910	12.1	2.4	0.5
1920 - 1980	1920	11.9	2.4	0.5
	1950	11.5	3.3	1
	1980	11.1	3.3	0.1
5200 - 5800	5200	-23.1	>19	>19
	5500	-18.6	>19	>19
	5800	15.9	18.4	19

Table 3. Performance at Vdd = Vsd = 1.8V, Idd = 7mA (R1 = 0 Ohm) nominal operating conditions

Symbol	Parameter and Test Condition	Units	Typ
G	Gain	dB	15.0
NF [1]	Noise Figure	dB	0.87
IP1dB	Input 1dB Compressed Power	dBm	-0.7
IIP3 [2]	Input 3rd Order Intercept Point (2-tone @ Fc +/- 2.5MHz)	dBm	+2
S11	Input Return Loss	dB	-9
S22	Output Return Loss	dB	-17.5

Notes:

1. Circuit losses not deembedded from demoboard. With losses deembedded, NF typical @1.575GHz = 0.82dB
2. 1.575 GHz IIP3 test condition: $F_{RF1} = 1572.5$ MHz, $F_{RF2} = 1577.5$ MHz with input power of -20 dBm per tone measured at the worst case side band

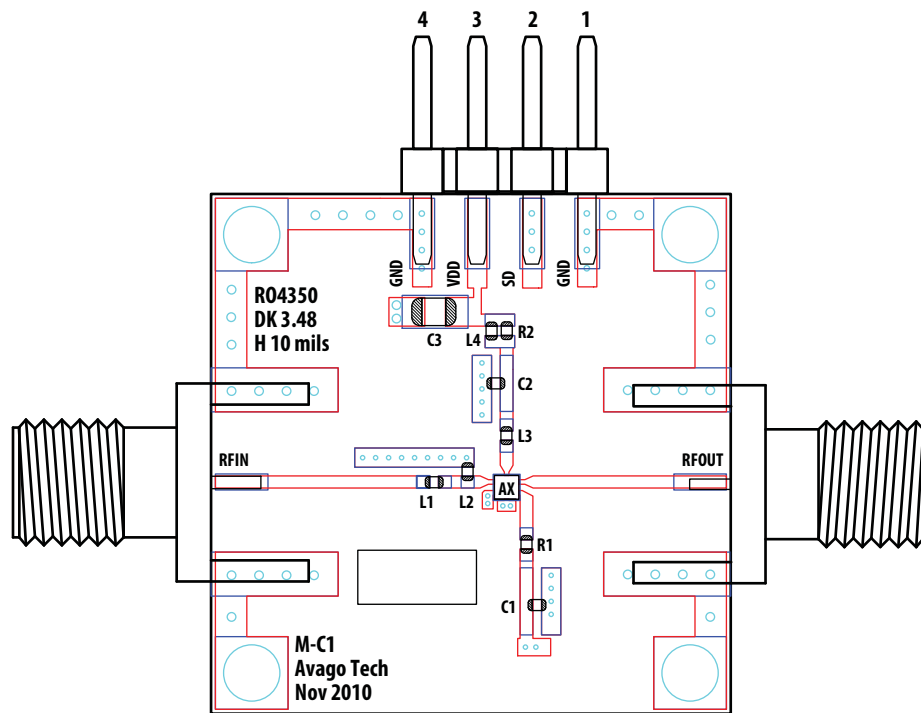

DC Pin Configuration of 4-pin connector

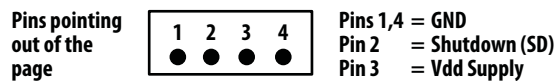

Circuit Symbol	Size	Description
L1	0402	8.2 nH Inductor (Taiyo Yuden AQ1058N2J-T)
L2	0402	15 nH Inductor (Taiyo Yuden AQ10515NJ-T)
L3	0402	3.9 nH Inductor (Taiyo Yuden HK10053N9S-T)
L4	0402	22 nH Inductor (Taiyo Yuden HK100522NJ-T)
C1	0402	7 pF Capacitor (Taiyo Yuden UMK105CH070CW-F)
C2	0402	8.2 pF Capacitor (Murata GJM1555C1H8R2DB01D)
C3	0805	0.1uF Capacitor (Murata GRM21BR71H104KA01L)
R1	0402	8.2 kohm Resistor (Kamaya RMC1/16S-822JTH)
R2	0402	12 ohm Resistor (Kamaya RMC1/16S-120JTH)

Figure 4. Demoboard and application circuit components table

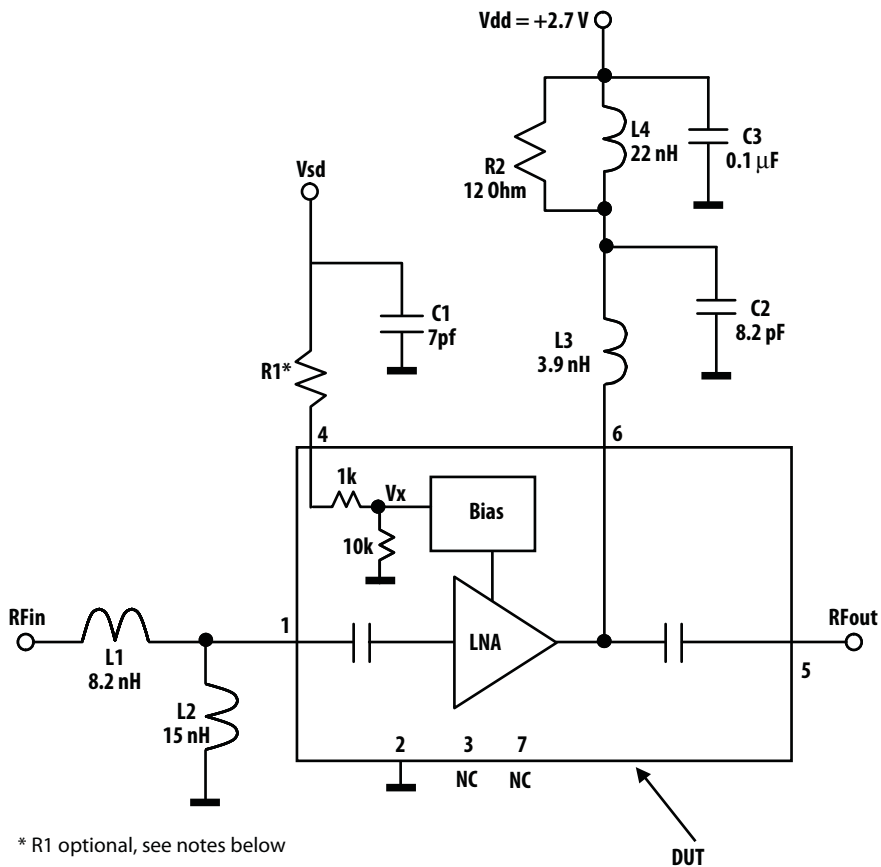

Figure 5. Application Circuit

Notes:

- L1 and L2 form the input matching network. The LNA module has integrated coupling and DC-block capacitors at the input and output respectively. Best noise performance is obtained using high-Q wirewound inductors. This circuit demonstrates that low noise figures are obtainable with standard 0402 chip inductors.
- L3 serves as an output matching inductor and supply choke.
- C1, C2 and C3 are RF bypass capacitors. C1 are optional.
- R2 and L4 form a network that isolates the measurement demoboard from external disturbances.
- The LNA bias current is variable. This enables the LNA to be used for different applications and gives slightly different performance at different bias currents. Best performance is obtained at higher currents. Typical bias is $V_{dd} = 2.7V$, $I_{dd} = 8\text{ mA}$.
- How the bias works:
 - Bias current of LNA is set by voltage at Vsd pin (pin 4).
 - Voltage at Vsd pin can be varied by either:
 - i. connecting Vsd directly to a voltage source ($R1 = 0\text{ Ohm}$), or
 - ii. connecting Vsd to a voltage source with a series resistor ($R1$ in Figure 5). The external voltage can be V_{dd} . The voltage drop across resistor $R1$ determines the voltage at pin 4. With example circuit of Figure 5 and $R1 = 8.2\text{ kOhm}$, current draw by Vsd pin (I_{sh}) is around $190\text{ }\mu\text{A}$.
 - Figs 9, 10 and 11 show the different bias currents that can be obtained by varying Vsd and $R1$.
- Higher gain and IP3 performance can be obtained by increasing the supply current. This can be achieved by reducing the value for $R1$ to obtain desired current.
- For low voltage operation such as $1.8V$, the $R1$ may be omitted and Vsd connected directly to the supply pins.

Unless otherwise stated, all measurements are made at $V_{dd}=V_{sd} = 2.7V$ and $I_{dd}=8mA$, $R_1=8.2k\Omega$

MGA-310G Typical Performance Curves at 25° C

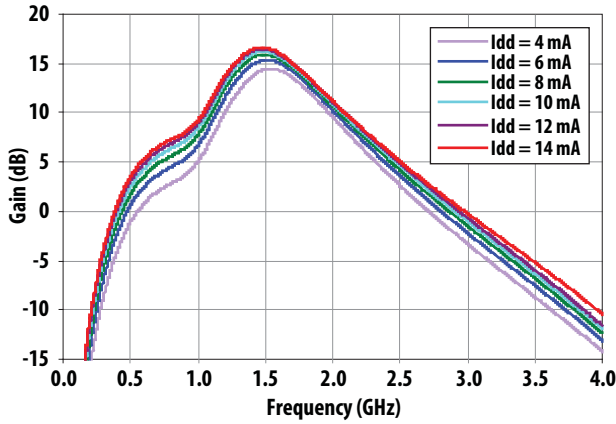

Figure 6. Typical S-Parameter Plot @ $V_{dd} = 2.7V$, $I_{dd} = 8mA$

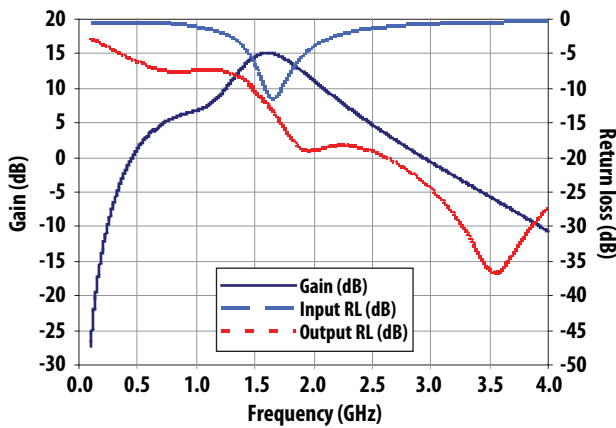

Figure 7a. Typical S-Parameter Plot @ $V_{dd} = 2.7V$, $I_{dd} = 8mA$

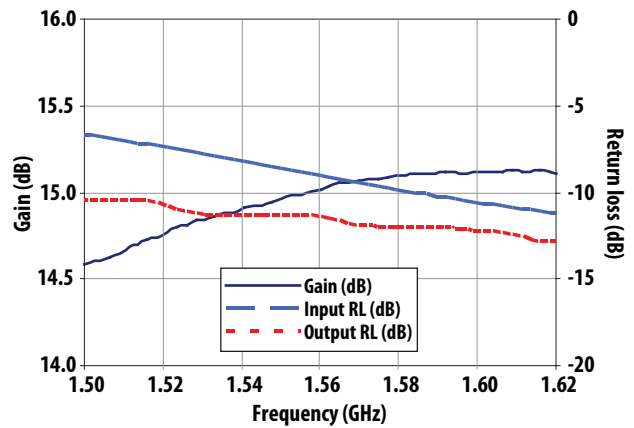

Figure 7b. Passband response of typical S-Parameter Plot @ $V_{dd} = 2.7V$, $I_{dd} = 8mA$

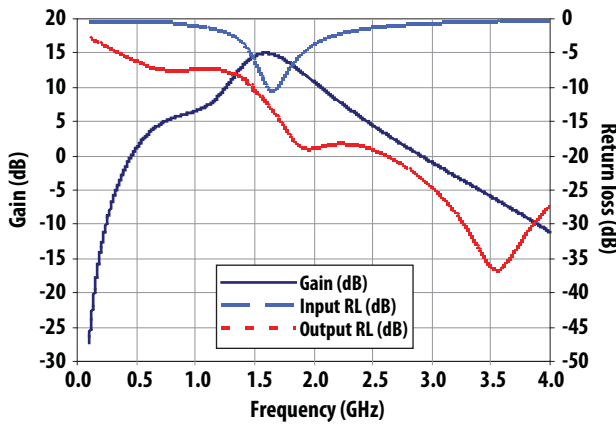

Figure 8a. Typical S-Parameter Plot @ $V_{dd} = 1.8V$, $I_{dd} = 7mA$

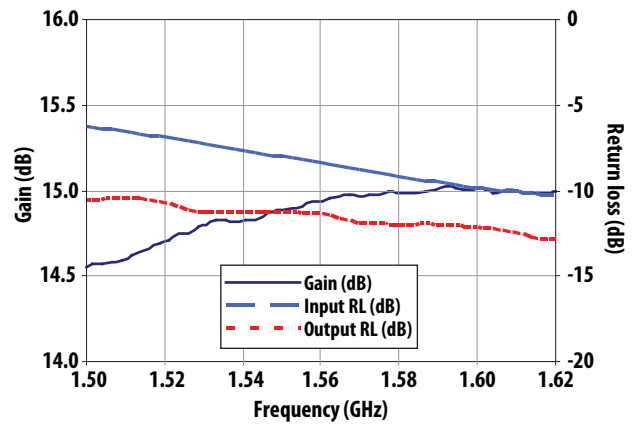

Figure 8b. Passband response of typical S-Parameter Plot @ $V_{dd} = 1.8V$, $I_{dd} = 7mA$

MGA-310G Typical Performance Curves at 25° C

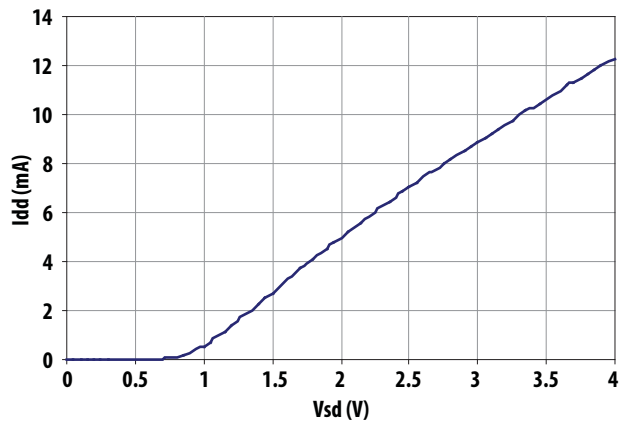

Figure 9. I_{dd} vs V_{sd} for $V_{dd} = 2.7$ V, $R1 = 8.2$ kOhm

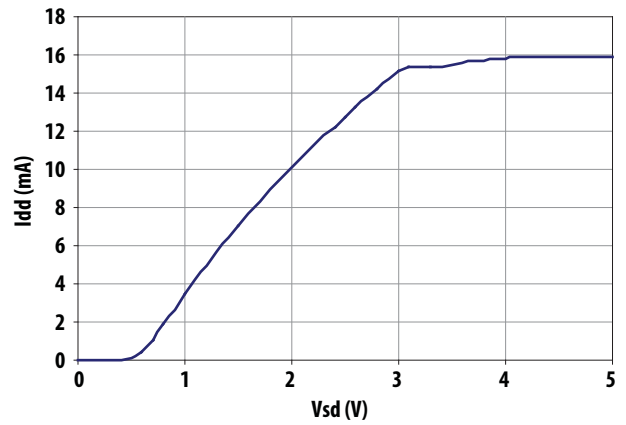

Figure 10. I_{dd} vs V_{sd} for $V_{dd} = 2.7$ V, $R1 = 0$ Ohm

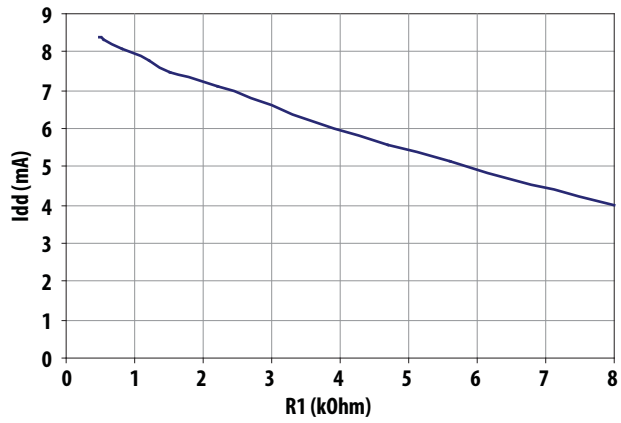

Figure 11. I_{dd} vs $R1$ for $V_{dd} = 2.7$ V, $V_{sd} = 1.8$ V

MGA-310G Typical Performance Curves @1.575GHz

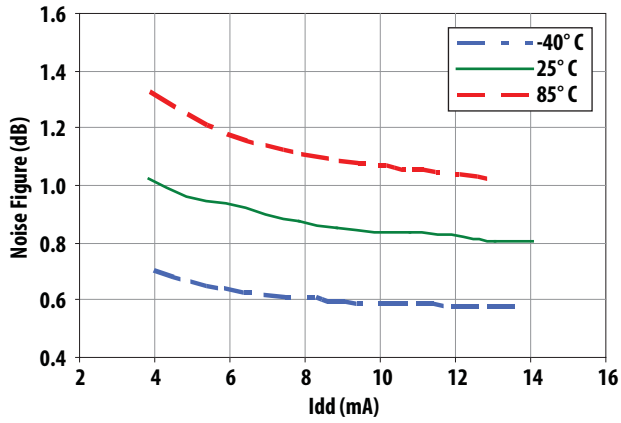

Figure 12. NF vs. Idd at Vdd = 2.7V

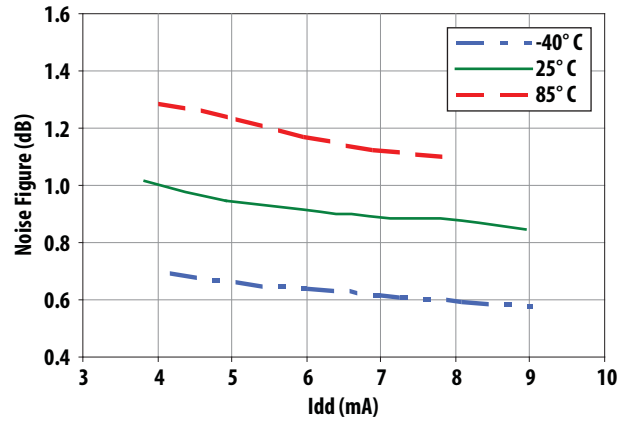

Figure 13. NF vs Idd at Vdd = 1.8V

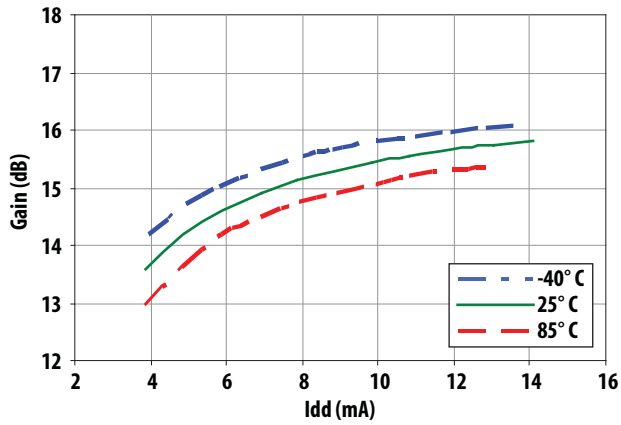

Figure 14. Gain vs. Idd at Vdd = 2.7V

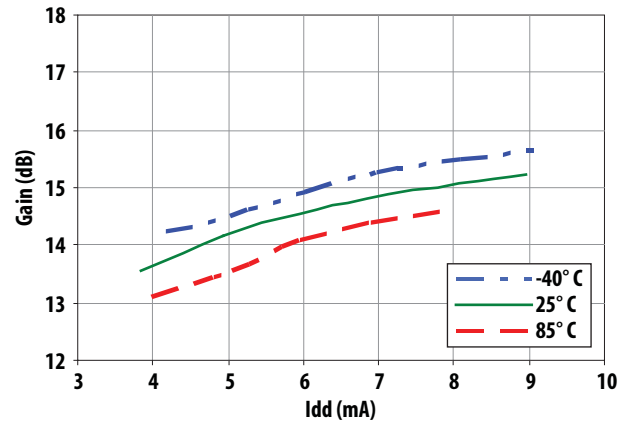

Figure 15. Gain vs. Idd at Vdd = 1.8V

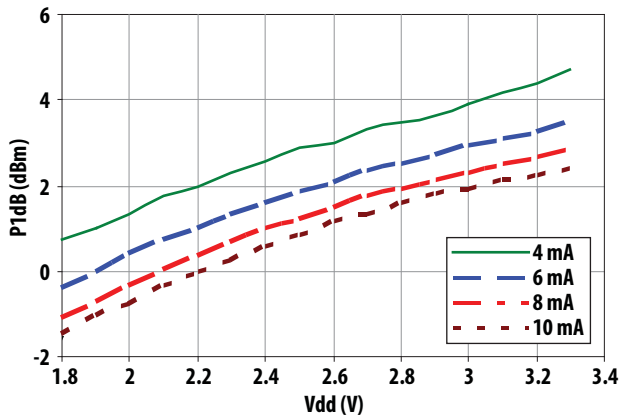

Figure 16. IP1dB vs. Vdd at 25°C

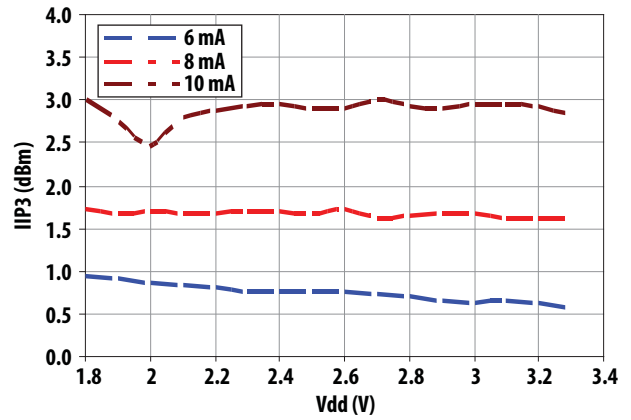

Figure 17. IIP3 vs. Vdd at 25°C

MGA-310G Typical Performance Curves

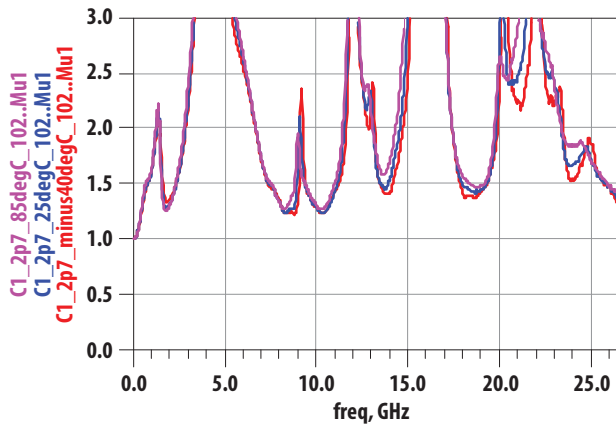

Figure 18. Edwards-Sinsky Output Stability Factor (μ) at $V_{dd} = 2.7V$, $I_{dd} = 8mA$

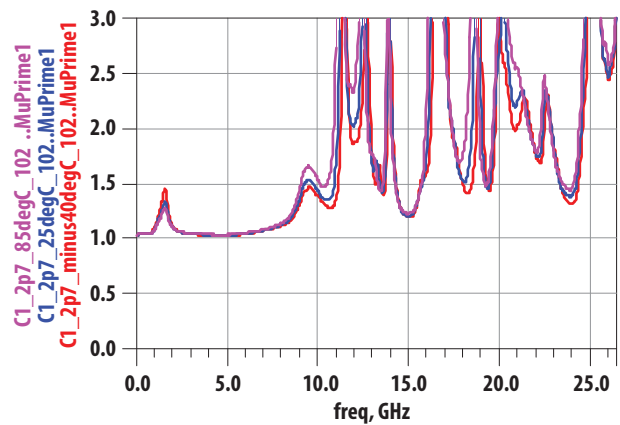

Figure 19. Edwards-Sinsky Input Stability Factor (μ') at $V_{dd} = 2.7V$, $I_{dd} = 8mA$

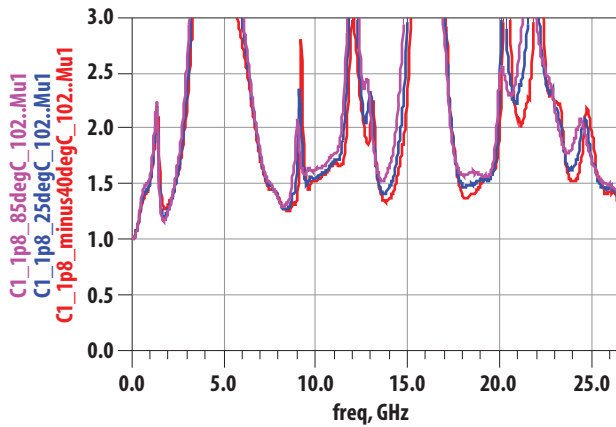

Figure 20. Edwards-Sinsky Output Stability Factor (μ) at $V_{dd} = 1.8V$, $I_{dd} = 7mA$

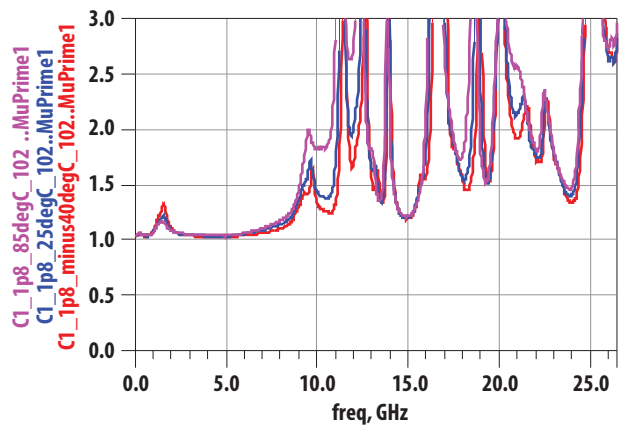

Figure 21. Edwards-Sinsky Input Stability Factor (μ') at $V_{dd} = 1.8V$, $I_{dd} = 7mA$

MGA-310G Measurement of 2nd harmonics of 787 MHz input signal, 25° C

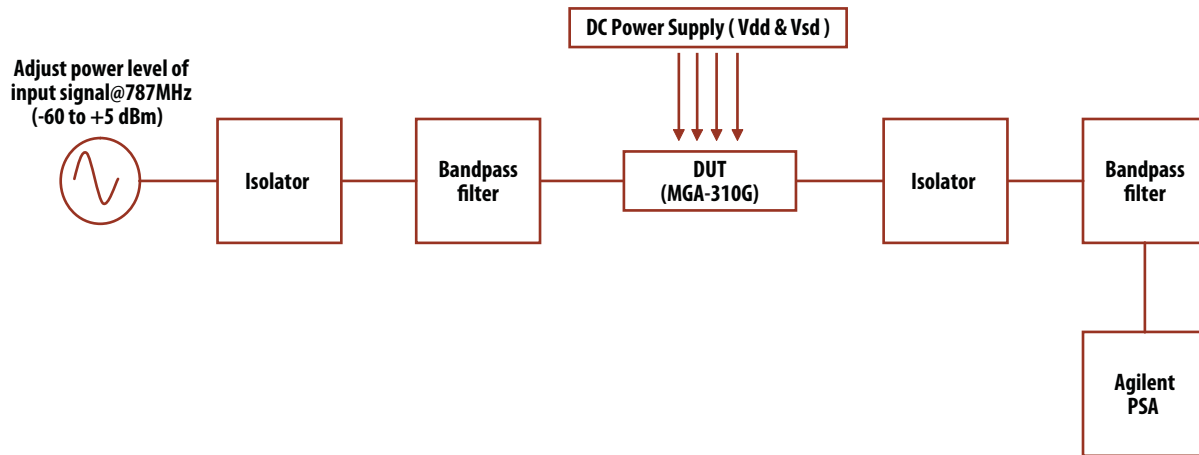

Figure 22. Setup diagram for measurement of 2nd harmonics of 787 MHz input signal

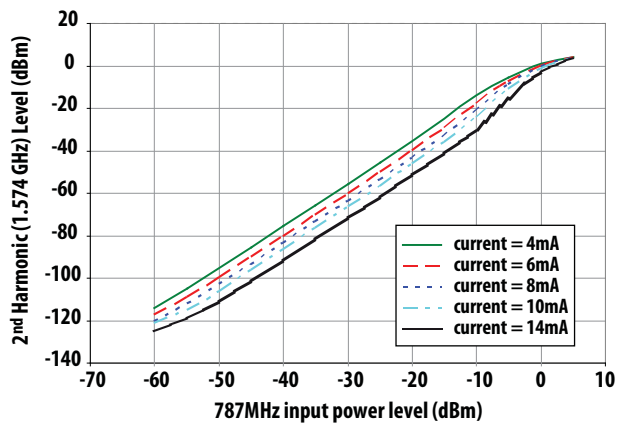

Figure 23. 2nd harmonics (1.574 GHz) vs 787 MHz input signal power level

MGA-310G RF performance @1.575GHz with 1710 MHz interferer signal at RF output, 25° C

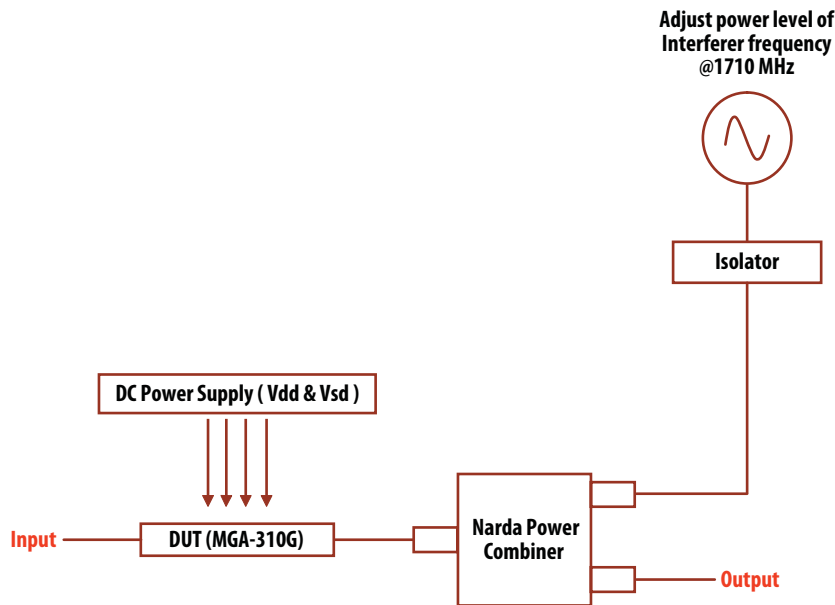

Figure 24. Setup diagram for measurement of RF performance with 1710 MHz interferer signal at RF output

Table 4. Measurement data for RF performance with 1710 MHz interferer signal at RF output

1710MHz interferer power level (dBm)		Vd (V)	Vg (V)	Id (mA)	Ig (mA)	Idsh (uA)	IIP3 (dBm)	IP1dB (dBm)	S11 (dB)	S22 (dB)	S21 (dB)	S12 (dB)	NF (dB)
1710MHz interferer power level (dBm)	Freq (Hz)												
No interfering signal	1575000000	2.7	2.7	8.9	0.131	0.17	2.1	2.0	-9.8	-14.5	15.2	-22.3	0.84
-11	1575000000	2.7	2.7	8.9	0.131	0.20	2.1	1.9	-9.8	-14.5	15.2	-22.3	0.95
-5	1575000000	2.7	2.7	8.8	0.131	0.32	2.1	1.9	-9.7	-14.4	15.1	-22.2	1.48
0	1575000000	2.7	2.7	8.7	0.131	0.78	2.0	1.7	-9.5	-14.2	15.1	-22.2	2.12

MGA-310G Scattering Parameter and Measurement Reference Planes

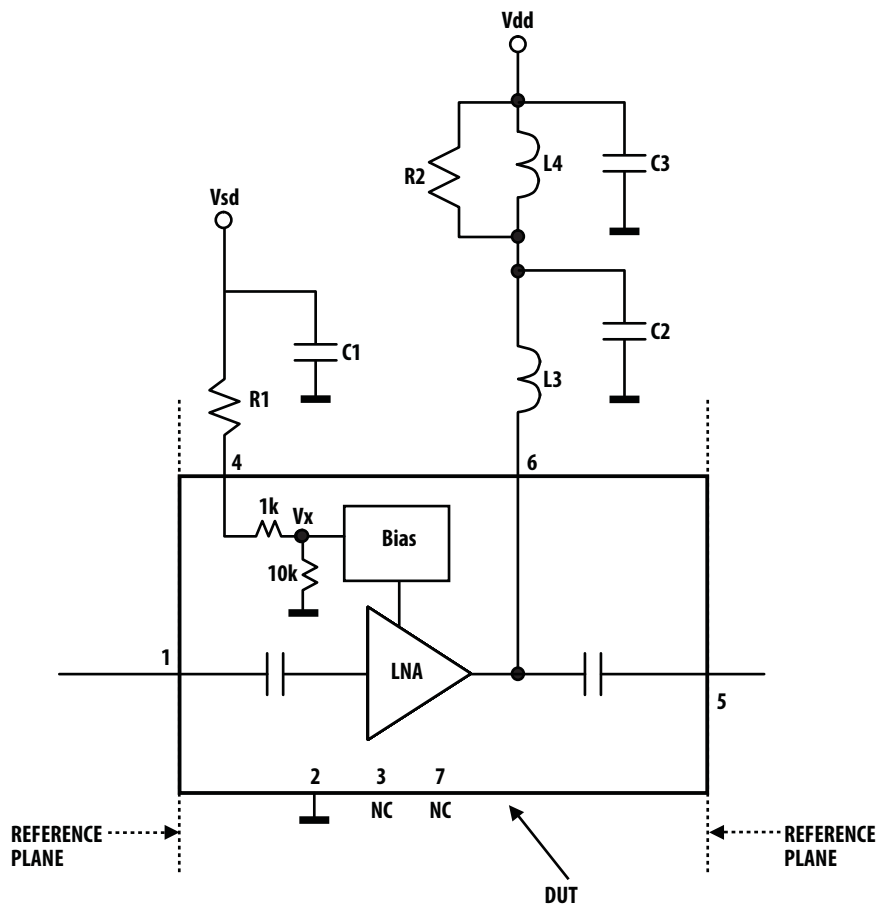

Figure 25. Scattering parameter measurement reference planes

**MGA-310G Typical Noise Parameters at 25° C,
Freq = 1.575 GHz, Vdd = 2.7 V, Idd = 8 mA**

Freq (GHz)	Fmin (dB)	GAMMA OPT		
		Mag	Ang	Rn/50
1.575	0.70	0.598	41.1	0.2466

**MGA-310G Typical Noise Parameters at 25° C,
Freq = 1.575 GHz, Vdd = 1.8 V, Idd = 7 mA**

Freq (GHz)	Fmin (dB)	GAMMA OPT		
		Mag	Ang	Rn/50
1.575	0.70	0.625	41.1	0.2658

Notes:

The exceptional noise figure performance of the MGA-310G is due to its highly optimized design. In this regard, the Fmin of the MGA-310G shown above is locked down by the internal input pre-match. This allows the use of relatively inexpensive chip inductors for external matching.

MGA-300G-AP1 Typical Scattering Parameters at 250C, Vdd = 2.7V, Idd = 8mA

The S- and Noise Parameters are measured using a coplanar waveguide PCB with 10 mils Rogers® RO4350. Figure 25 shows the input and output reference planes. The circuit values are as indicated in Figure 4.

Freq	S11	S11	S21	S21	S12	S12	S22	S22
(GHz)	Mag. (dB)	Ang.	Mag. (dB)	Ang.	Mag. (dB)	Ang.	Mag. (dB)	Ang.
0.05	-0.04	-1.41	-21.68	-31.85	-64.95	85.10	-0.01	-7.95
0.1	-0.04	-2.70	-12.01	-52.60	-59.61	84.80	-0.08	-16.19
0.2	-0.09	-5.56	-3.72	-77.13	-55.33	97.41	-0.36	-32.79
0.3	-0.18	-8.47	0.63	-94.27	-50.77	114.09	-0.92	-49.18
0.4	-0.36	-11.61	3.47	-109.86	-46.32	128.35	-1.80	-65.52
0.5	-0.25	-19.23	5.84	-124.12	-41.66	129.29	-2.85	-79.54
0.6	-0.42	-23.11	6.89	-137.53	-38.73	125.28	-4.01	-91.16
0.7	-0.63	-26.79	7.45	-149.96	-36.42	119.68	-5.08	-100.62
0.8	-0.87	-29.95	7.28	-160.98	-35.10	112.51	-5.66	-107.38
0.9	-1.00	-32.92	7.06	-164.80	-34.46	112.25	-5.83	-118.53
1.0	-1.11	-35.34	7.24	-166.78	-33.56	115.16	-6.39	-129.78
1.1	-1.24	-37.55	7.26	-170.44	-32.73	115.86	-6.72	-138.83
1.2	-1.30	-40.69	7.59	-171.29	-31.78	120.45	-6.65	-153.36
1.3	-1.33	-44.36	8.41	-173.12	-30.17	124.92	-6.80	-170.69
1.4	-1.39	-48.59	9.37	-177.91	-28.23	125.62	-7.31	170.73
1.5	-1.54	-53.08	10.13	174.88	-26.46	122.59	-8.18	152.46
1.575	-1.69	-56.40	10.50	168.81	-25.37	119.02	-9.01	139.58
1.6	-1.75	-57.48	10.59	166.77	-25.06	117.72	-9.31	135.48
1.7	-2.02	-61.62	10.78	158.78	-24.01	112.51	-10.57	120.02
1.8	-2.31	-65.44	10.80	151.37	-23.20	107.65	-11.89	105.96
1.9	-2.61	-68.97	10.72	144.62	-22.55	103.31	-13.21	92.97
2.0	-2.90	-72.24	10.56	138.50	-22.01	99.48	-14.50	80.63
2.1	-3.19	-75.28	10.37	132.93	-21.54	96.11	-15.76	68.52
2.2	-3.47	-78.15	10.16	127.80	-21.12	93.13	-16.96	56.41
2.3	-3.74	-80.85	9.94	123.06	-20.74	90.46	-18.08	44.01
2.4	-4.01	-83.42	9.71	118.63	-20.38	88.03	-19.05	31.02
2.5	-4.27	-85.87	9.48	114.46	-20.04	85.81	-19.84	17.58
3.0	-5.59	-96.66	8.33	96.68	-18.55	76.73	-20.09	-43.67
3.5	-6.96	-106.21	7.27	82.25	-17.26	69.53	-17.86	-76.79
4.0	-8.33	-115.93	6.32	69.89	-16.12	63.14	-16.31	-93.57
4.5	-9.42	-126.40	5.47	58.85	-15.06	57.06	-15.55	-104.45
5.0	-10.40	-137.44	4.73	48.36	-14.09	50.70	-14.41	-116.78
6.0	-12.39	-152.02	3.48	28.30	-12.35	36.99	-12.28	-139.44
7.0	-16.94	-161.35	2.15	7.77	-11.12	20.80	-10.10	-165.25
8.0	-26.86	-133.14	0.52	-13.95	-10.47	1.59	-6.72	179.82
9.0	-15.68	-111.25	-2.29	-35.92	-11.22	-20.35	-3.88	159.91
10.0	-9.13	-135.91	-5.99	-50.16	-13.21	-37.23	-3.02	138.56
11.0	-5.21	-173.90	-8.95	3.13	-18.01	16.00	-3.01	99.07
12.0	-4.85	166.87	-6.95	0.49	-14.35	18.37	-3.40	83.38
13.0	-5.04	157.27	-7.97	-15.53	-14.42	-2.44	-3.80	79.89
14.0	-4.46	138.78	-6.07	-19.06	-11.72	-3.63	-4.59	65.29
15.0	-3.98	121.40	-4.19	-26.93	-9.21	-9.09	-6.14	55.84
16.0	-4.01	118.15	-4.62	-40.59	-9.12	-22.39	-7.40	65.55
17.0	-4.72	128.48	-6.98	-72.27	-10.78	-58.11	-6.12	84.18
18.0	-2.05	103.58	-5.82	-58.22	-9.50	-35.32	-6.09	51.27
19.0	-1.52	85.85	-5.78	-70.75	-8.51	-47.08	-5.51	48.86
20.0	-0.91	77.48	-6.70	-78.71	-8.68	-55.63	-4.78	58.36

MGA-300G-AP1 Typical Scattering Parameters at 250C, Vdd = 1.8V, Idd = 7mA

Freq (GHz)	S11 Mag.	S11 Ang.	S21 Mag.	S21 Ang.	S12 Mag.	S12 Ang.	S22 Mag.	S22 Ang.
0.05	-0.03	-1.53	-21.70	-31.07	-63.31	77.17	-0.01	-7.94
0.1	-0.04	-3.04	-12.00	-53.10	-58.86	90.18	-0.08	-16.18
0.2	-0.12	-6.08	-3.81	-78.32	-55.54	103.44	-0.37	-32.72
0.3	-0.23	-9.04	0.44	-95.55	-50.32	119.09	-0.93	-49.09
0.4	-0.43	-12.13	3.21	-111.10	-45.73	131.05	-1.80	-65.20
0.5	-0.14	-18.72	5.47	-123.97	-40.84	132.92	-2.78	-79.18
0.6	-0.03	-23.40	6.78	-137.58	-37.84	128.42	-4.16	-90.20
0.7	-0.22	-27.08	7.36	-149.87	-35.53	121.98	-5.22	-99.49
0.8	-0.44	-30.41	7.39	-161.11	-34.04	114.97	-5.97	-106.15
0.9	-0.50	-32.33	5.90	-159.58	-35.00	116.15	-4.91	-117.99
1.0	-0.69	-36.56	7.34	-168.91	-32.30	114.71	-6.58	-127.78
1.1	-0.82	-38.65	7.06	-171.08	-31.87	115.99	-6.82	-135.72
1.2	-0.88	-41.69	7.40	-171.43	-30.92	120.93	-6.75	-150.34
1.3	-0.91	-45.38	8.28	-173.16	-29.24	125.15	-6.95	-167.65
1.4	-1.00	-49.66	9.28	-178.29	-27.24	125.20	-7.56	174.09
1.5	-1.18	-54.10	10.03	174.21	-25.52	121.44	-8.58	156.45
1.575	-1.36	-57.31	10.36	168.06	-24.48	117.63	-9.52	144.27
1.6	-1.43	-58.35	10.44	166.01	-24.19	116.28	-9.86	140.41
1.7	-1.75	-62.30	10.61	158.08	-23.20	110.97	-11.30	126.07
1.8	-2.07	-65.85	10.62	150.81	-22.42	106.17	-12.84	113.18
1.9	-2.40	-69.19	10.52	144.15	-21.80	101.87	-14.43	101.38
2.0	-2.71	-72.28	10.36	138.15	-21.28	98.04	-16.07	90.25
2.1	-3.02	-75.18	10.17	132.68	-20.83	94.68	-17.81	79.22
2.2	-3.33	-77.98	9.96	127.61	-20.42	91.73	-19.59	67.39
2.3	-3.63	-80.60	9.73	122.96	-20.04	89.03	-21.46	54.59
2.4	-3.91	-83.11	9.49	118.59	-19.70	86.63	-23.30	38.85
2.5	-4.18	-85.57	9.26	114.49	-19.38	84.37	-24.91	19.70
3.0	-5.45	-96.66	8.10	97.06	-17.95	75.39	-22.67	-66.97
3.5	-6.65	-106.19	7.02	82.85	-16.70	68.09	-18.42	-92.59
4.0	-7.78	-114.49	6.05	70.59	-15.58	61.35	-16.18	-102.69
4.5	-8.69	-122.37	5.18	59.50	-14.58	54.27	-14.79	-109.17
5.0	-9.08	-132.28	4.28	50.35	-14.04	47.23	-13.21	-121.05
6.0	-12.27	-161.01	3.49	30.71	-11.98	37.79	-12.59	-155.03
7.0	-15.21	-171.57	2.39	10.97	-10.62	22.67	-9.82	-171.55
8.0	-20.88	-148.25	0.98	-11.78	-9.70	2.33	-6.66	178.62
9.0	-14.28	-114.78	-1.93	-35.02	-10.62	-21.34	-3.91	159.59
10.0	-8.79	-133.83	-5.65	-50.04	-12.62	-38.85	-2.78	136.92
11.0	-4.03	-177.37	-8.81	4.34	-17.54	15.62	-2.34	99.48
12.0	-3.85	161.80	-6.56	0.37	-14.19	14.35	-3.46	86.07
13.0	-4.66	153.11	-7.57	-15.88	-13.95	-5.39	-3.72	80.96
14.0	-4.29	135.40	-5.45	-22.04	-11.69	-5.75	-4.51	70.53
15.0	-3.30	120.18	-4.38	-31.77	-9.30	-9.54	-4.76	66.94
16.0	-3.26	119.01	-5.10	-44.25	-9.38	-22.76	-5.56	71.81
17.0	-4.05	124.98	-7.03	-71.06	-9.90	-50.93	-4.63	76.53
18.0	-1.73	100.67	-6.46	-48.61	-9.02	-31.36	-3.16	41.31
19.0	-1.33	80.83	-5.95	-60.55	-8.06	-42.91	-3.19	38.32
20.0	-0.73	69.37	-5.56	-69.81	-7.42	-53.13	-4.37	44.05

Part Number Ordering Information

Part Number	Qty	Container
MGA-310G-TR1	3000	7" Reel
MGA-310G-BLK	100	Antistatic Bag

Package Dimensions

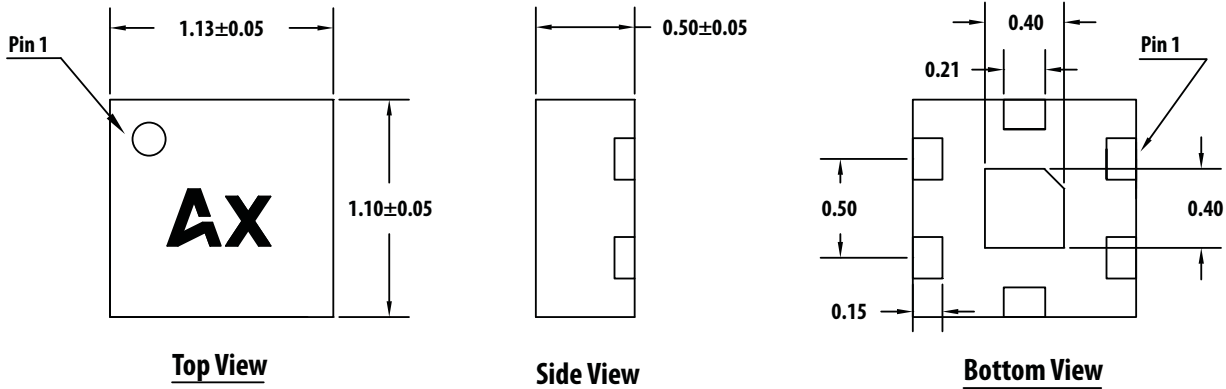

Notes:

1. All dimensions are in millimeters.
2. Dimensions are inclusive of plating.
3. Dimensions are exclusive of mold flash and metal burr.
4. M refer to product code, X refer to month/year code.

PCB Land Patterns and Stencil Design

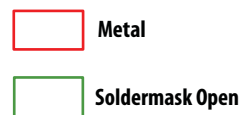
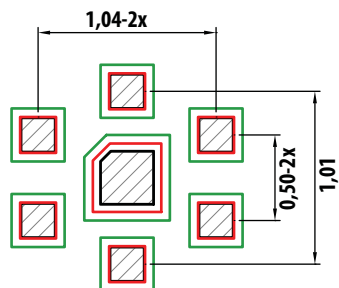
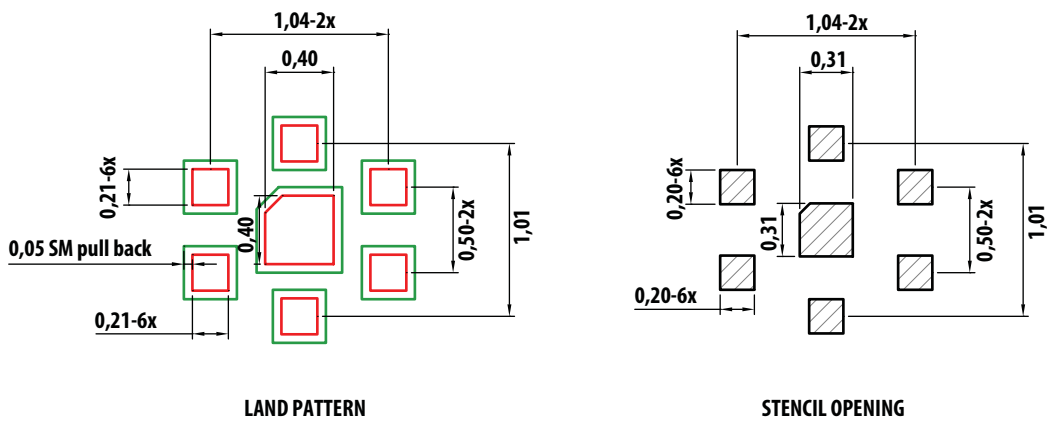

Notes:

1. Recommended Land Pattern & Stencil Opening.
2. Stencil thickness is 0.075 mm (3 mils).
3. All dimension are in mm unless otherwise specified.

COMBINATION OF LAND PATTERN AND STENCIL OPENING

Device Orientation

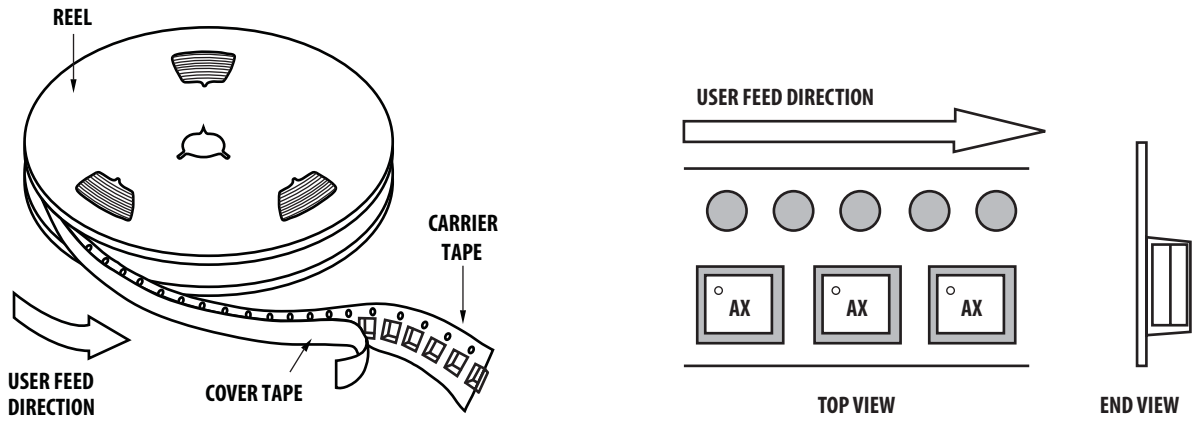

Tape Dimensions

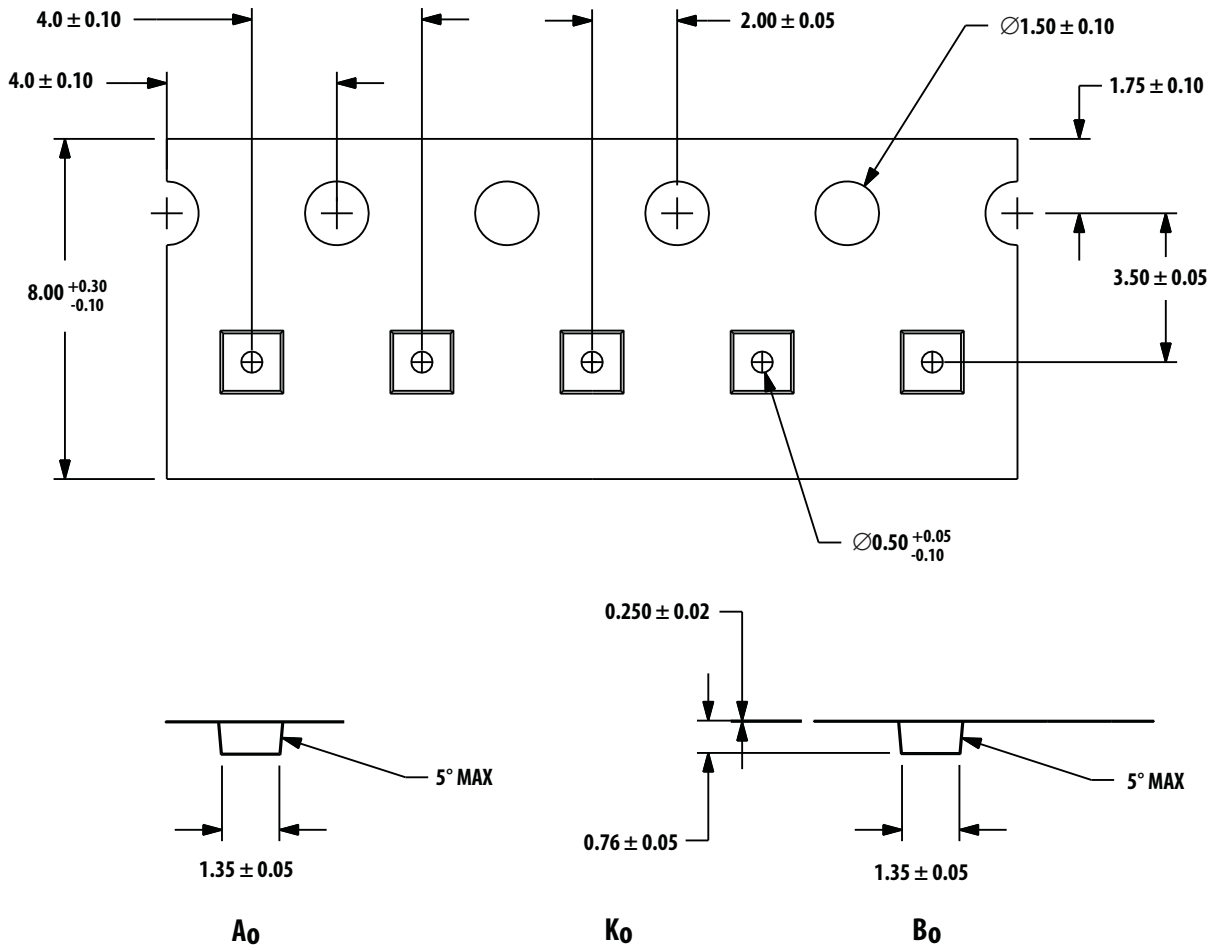

Note: dimensions in mm

Reel Dimensions (7" reel)

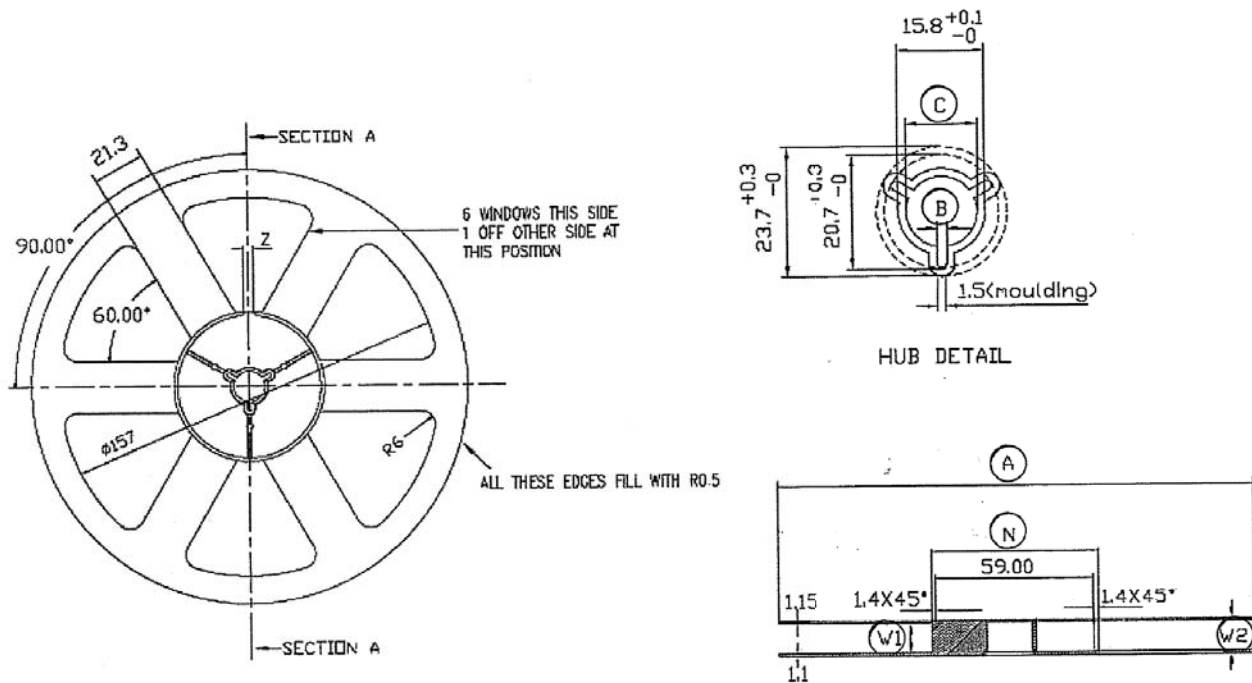

Type Size	A	B	C	N	W1	W2	Z
8 mm	$\phi 180^{+1}_{-0}$	$1.6^{+0.2}_{-0}$	$\phi 12.8^{+1}_{-4}$	$62^{+0.2}_{-0.2}$	$8.4^{+1.5}_{-0}$	14.4 Max	$4.0^{+0.5}_{-0.2}$

For product information and a complete list of distributors, please go to our web site: www.avagotech.com

Avago, Avago Technologies, and the A logo are trademarks of Avago Technologies in the United States and other countries. Data subject to change. Copyright © 2005-2011 Avago Technologies. All rights reserved. AV02-2868EN - July 26, 2011

AVAGO
TECHNOLOGIES