

# MGA-636P8

## High Linearity Low Noise Amplifier



### Data Sheet

#### Description

Avago Technologies' MGA-636P8 is an economical, easy-to-use GaAs MMIC Low Noise Amplifier (LNA). This LNA has low noise and high linearity achieved through the use of Avago Technologies' proprietary 0.25  $\mu\text{m}$  GaAs Enhancement-mode pHEMT process. It is housed in the miniature 2.0 x 2.0 x 0.75 mm<sup>3</sup> 8-pin Dual-Flat-Non-Lead (DFN) package. The device is designed for optimum use from 450 MHz up to 1.5 GHz. The compact footprint and low profile coupled with low noise, high gain and high linearity make this an ideal choice as a low noise amplifier for cellular infrastructure applications such as LTE, GSM, CDMA, W-CDMA, CDMA2000 & TD-SCDMA. For optimum performance at lower frequency from 1.5 GHz up to 2.5 GHz, MGA-637P8 is recommended. For optimum performance at higher frequency from 2.5 GHz up to 4 GHz, MGA-638P8 is recommended. All these 3 products, MGA-636P8, MGA-637P8 and MGA-638P8 share the same package and pinout configuration.

#### Pin Configuration and Package Marking

2.0 x 2.0 x 0.75 mm<sup>3</sup> 8-lead DFN

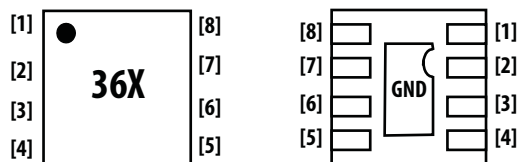

TOP VIEW

- Pin 1 – Not Used
- Pin 2 – RFin
- Pin 3 – Vbias2
- Pin 4 – Not Used
- Center paddle – GND

BOTTOM VIEW

- Pin 5 – Vbias1
- Pin 6 – PwrDwn
- Pin 7 – RFout
- Pin 8 – Not Used

Note:  
 Package marking provides orientation and identification  
 "36" = Product Code  
 "X" = Month Code

It is recommended to ground Pin1, 4 and 8 which are Not Used.

#### Features

- High linearity performance.
- Low Noise Figure.
- GaAs E-pHEMT Technology<sup>[1]</sup>.
- Low cost small package size.
- Integrated with active bias and option to access FET gate.
- Integrated power down control pin.

#### Specifications

700 MHz; 4.8 V, 108 mA

- 18.8 dB Gain
- 0.44 dB Noise Figure
- 11 dB Input Return Loss
- +23.7 dBm Input IP3
- +23.8 dBm Output Power at 1 dB gain compression

#### Applications

- Cellular infrastructure applications such as LTE, GSM, CDMA, W-CDMA, CDMA2000 & TD-SCDMA.
- Other low noise applications.

Note:

1. Enhancement mode technology employs positive Vgs, thereby eliminating the need of negative gate voltage associated with conventional depletion mode devices.



**Attention: Observe precautions for handling electrostatic sensitive devices.**  
 ESD Machine Model = 70 V  
 ESD Human Body Model = 300 V  
 Refer to Avago Application Note A004R: Electrostatic Discharge, Damage and Control.

## Simplified Schematic<sup>[1]</sup>

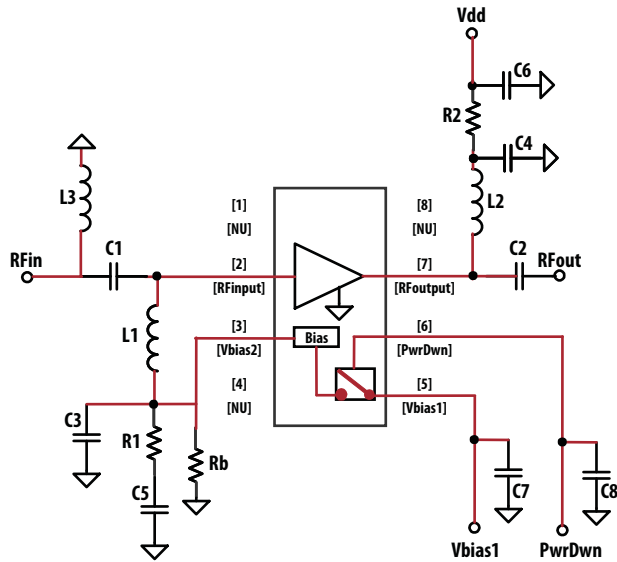

Note:

1. Device is turned ON when PwrDwn pin is applied with 0 V or left open. Device is turned OFF when PwrDwn pin is applied with 3.3 V.

## Absolute Maximum Rating<sup>[1]</sup> $T_A=25^\circ\text{C}$

Symbol	Parameter	Units	Absolute Maximum
$V_{dd}$	Device Voltage, RF output to ground	V	5.5
$I_{dd}$	Drain Current	mA	130
$V_{bias1}$	Bias Voltage	V	5.5
$V_{PwrDwn}$	Power Down Voltage	V	5.5
$P_{in,max}$	CW RF Input Power	dBm	+24
$P_{diss}$	Total Power Dissipation	W	0.72
$T_j$	Junction Temperature	$^\circ\text{C}$	150
$T_{stg}$	Storage Temperature	$^\circ\text{C}$	-65 to 150

## Thermal Resistance

### Thermal Resistance<sup>[2]</sup>

( $V_{dd} = 4.8\text{ V}$ ,  $I_{dd} = 108\text{ mA}$ )

$\theta_{jc} = 79.6^\circ\text{C/W}$

Notes:

1. Operation of this device in excess of any of these limits may cause permanent damage.
2. Thermal resistance measured using Infra-Red Measurement Technique.
3. Power dissipation with unit turned on. Board temperature  $T_c$  is  $25^\circ\text{C}$ . Derate at  $12.6\text{ mW}/^\circ\text{C}$  for  $T_c > 93^\circ\text{C}$ .

## Electrical Specifications [1, 4]

$T_A = 25^\circ\text{C}$ ,  $V_{dd} = V_{bias1} = 4.8\text{ V}$ , RF measurement at 700 MHz, measured on demo board in Figure 5 with component listed in Table 1.

Symbol	Parameter and Test Condition	Units	Min.	Typ.	Max.
I <sub>dd</sub>	Drain Current	mA	89	108	126
I <sub>PwrDwn</sub>	Current at V <sub>PwrDwn</sub> pin when V <sub>PwrDwn</sub> = 3.3 V (Power Down mode)	mA	–	0.15	–
Gain	Gain	dB	17.5	18.8	20.5
NF <sup>[2]</sup>	Noise Figure	dB	–	0.44	0.8
IIP3 <sup>[3]</sup>	Input Third Order Intercept Point	dBm	22	23.7	–
OP1dB	Output Power at 1dB Gain Compression	dBm	–	23.8	–
IRL	Input Return Loss, 50 Ω source	dB	–	11	–
ORL	Output Return Loss, 50 Ω load	dB	–	21	–

Notes:

1. Measurements at 700 MHz obtained using demo board described in Figure 5.
2. For NF data, board losses of the input have not been de-embedded.
3. IIP3 test condition:  $F_{RF1} = 700\text{ MHz}$ ,  $F_{RF2} = 701\text{ MHz}$  with input power of -10 dBm per tone.
4. Use proper bias, heatsink and derating to ensure maximum channel temperature is not exceeded. See absolute maximum ratings and application note for more details.

## Product Consistency Distribution Charts [1, 2]

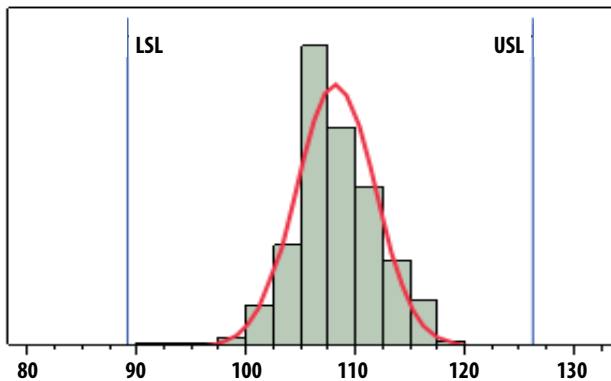

Figure 1. I<sub>dd</sub>, LSL = 89 mA, nominal = 108 mA, USL = 126 mA

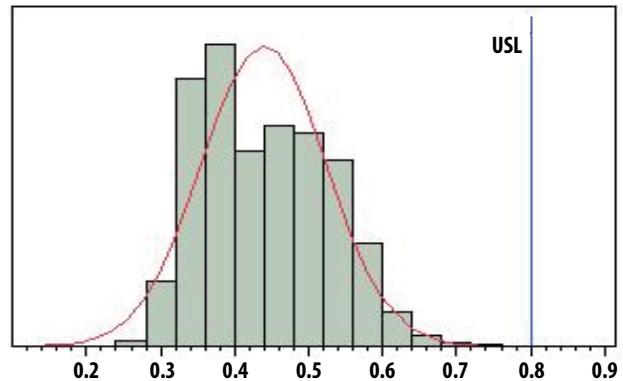

Figure 2. NF, nominal = 0.44 dB, USL = 0.8 dB

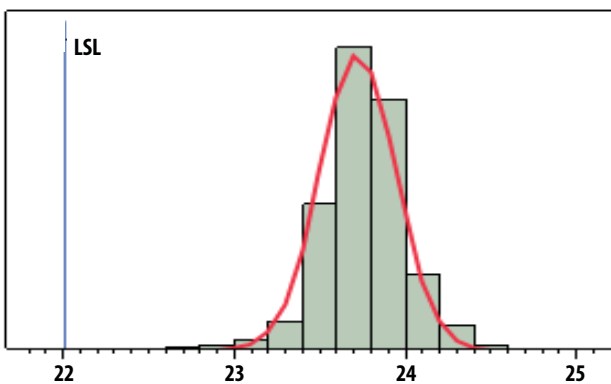

Figure 3. IIP3, LSL = 22 dBm, nominal = 23.7 dBm

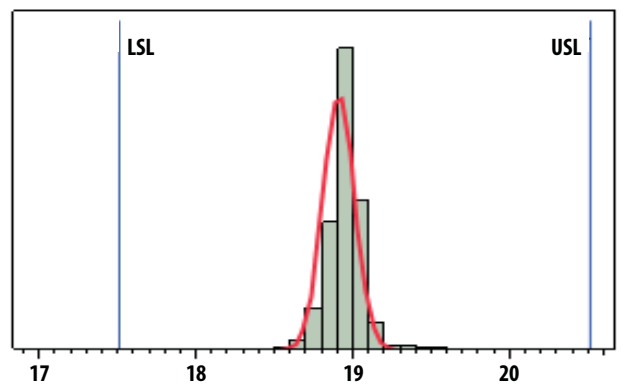

Figure 4. Gain, LSL = 17.5 dB, nominal = 18.8 dB, USL = 20.5 dB

Notes:

1. Distribution data sample size is 500 samples taken from 3 different wafer lots. Future wafers allocated to this product may have nominal values anywhere between the upper and lower limits.
2. Circuit trace losses have not been de-embedded from measurements above.

## Demo Board Layout

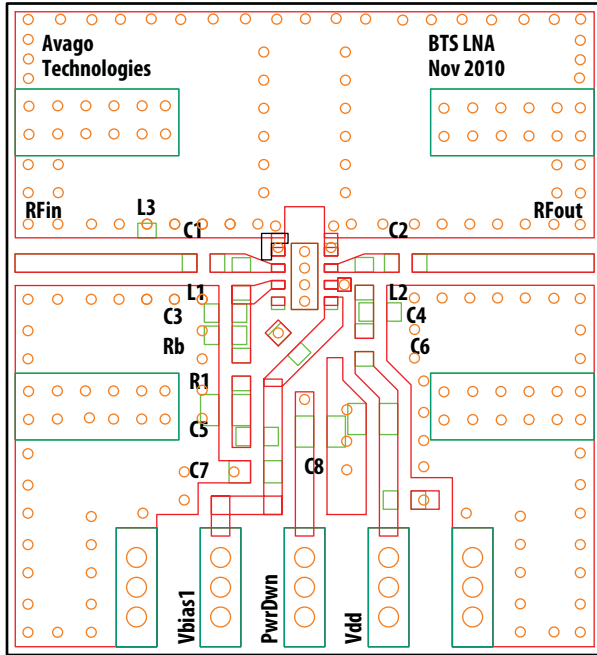
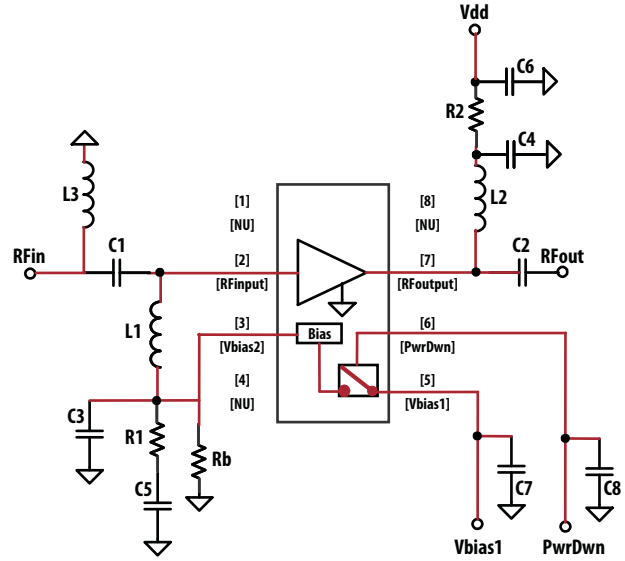

Figure 5. Demo Board Layout Diagram

- Recommended PCB material is 10 mils Rogers RO4350.
- Suggested component values may vary according to layout and PCB material.

## Demo Board Schematic



### Truth Table

	V <sub>PwrDwn</sub> (V)
LNA Mode	0 or open
Power Down Mode	3.3

Figure 6. Demo Board Schematic Diagram

### Notes:

- The schematic is shown with the assumption that similar PCB is used for all MGA-636P8, MGA-637P8 and MGA-638P8.
- Detail of the components needed for this product is shown in Table 1.

Table 1. Component list for 700 MHz matching

Part	Size	Value	Detail Part Number
C1, C2, C4	0402	100 pF (Murata)	GRM1555C1H101JD01D
C3	0402	27 pF (Murata)	GRM1555C1H270JA01D
C5, C6, C7, C8	0402	4.7 μF (Murata)	GRM188R60J475KE19D
L1, L2	0402	33 nH (Toko)	LL1005-FHL33NJ
L3	0402	Not Used	
Rb	0402	Not Used	
R1	0402	51 ohm (Rohm)	MCR004YZPJ510
R2	0402	0 ohm (Rohm)	MCR01MZPJ000

### Notes:

- C1, C2 are DC blocking capacitors
- L1 input match for NF
- L2 output match for IP3
- C3, C4, C5, C6, C7, C8 are bypass capacitors
- R1 is a stabilizing resistor
- Rb is the biasing resistor (not used)

## Typical Performance

RF performance at  $T_A = 25^\circ\text{C}$ ,  $V_{dd} = 4.8\text{V}$ ,  $I_{dd} = 100\text{mA}$ , measured using 50 ohm input and output board unless stated otherwise. IIP3 test condition:  $F_{RF1}-F_{RF2} = 1\text{MHz}$  with input power of  $-10\text{dBm}$  per tone.

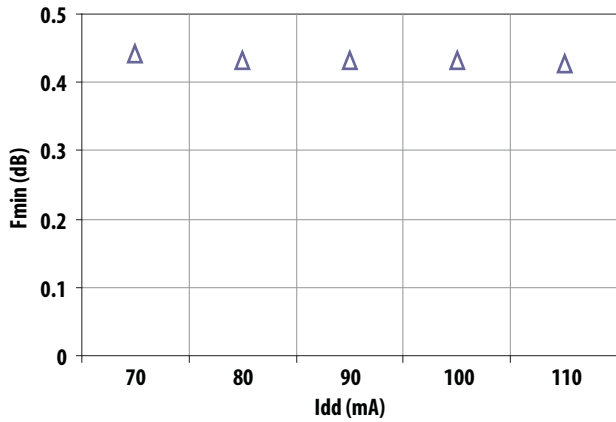

Figure 7. Fmin vs Idd at 4.8 V at 700 MHz

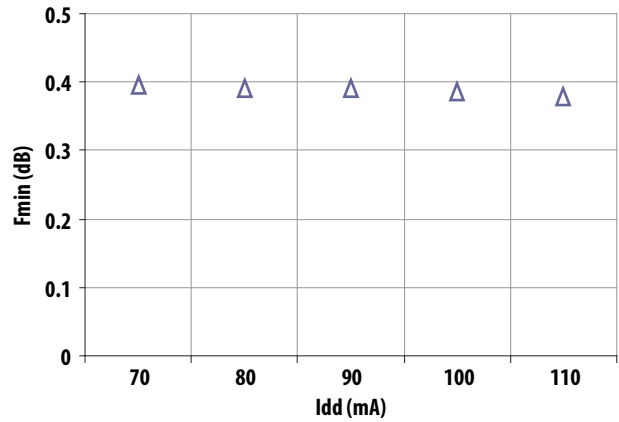

Figure 8. Fmin vs Idd at 4.8 V at 900 MHz

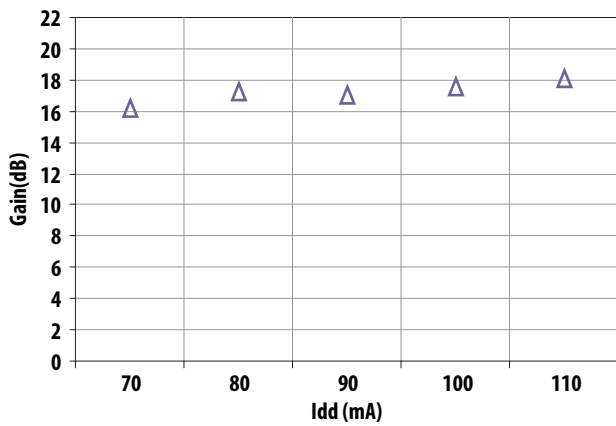

Figure 9. Gain vs Idd at 4.8 V Tuned for Optimum IIP3 and Fmin at 700 MHz

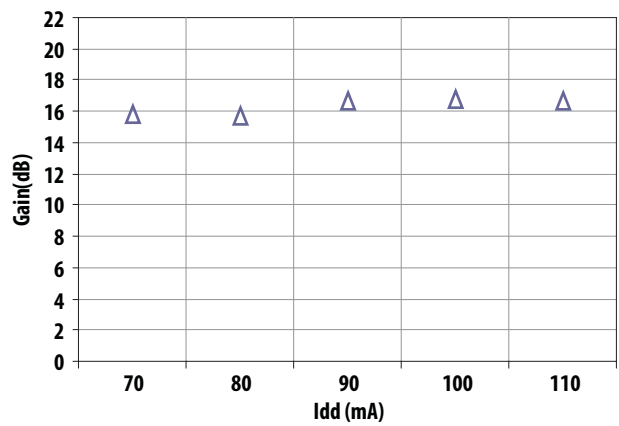

Figure 10. Gain vs Idd at 4.8 V Tuned for Optimum IIP3 and Fmin at 900 MHz

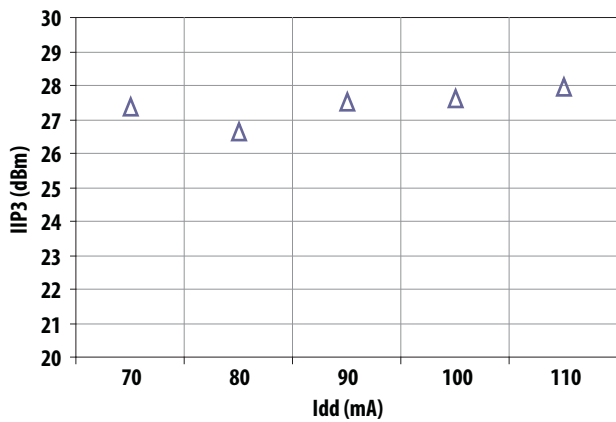

Figure 11. IIP3 vs Idd at 4.8 V Tuned for Optimum IIP3 and Fmin at 700 MHz

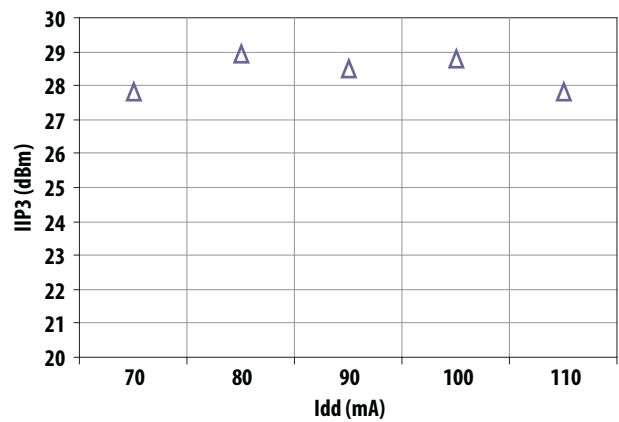

Figure 12. IIP3 vs Idd at 4.8 V Tuned for Optimum IIP3 and Fmin at 900 MHz

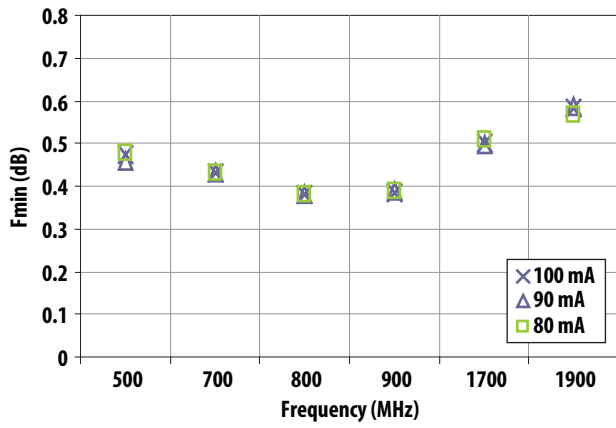

Figure 13. Fmin vs Frequency and Idd at 4.8 V

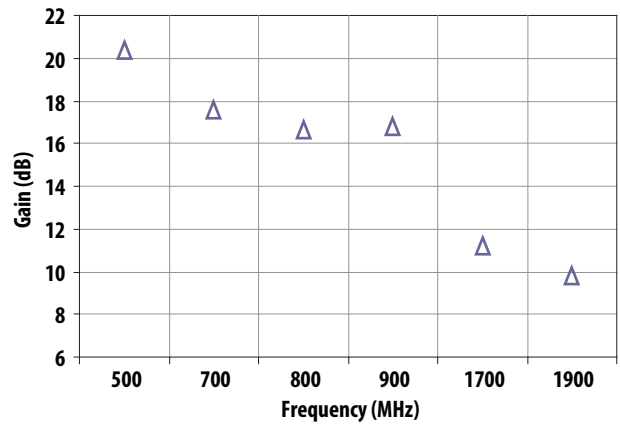

Figure 14. Gain vs Frequency for Optimum IIP3 and Fmin at 4.8 V 100 mA

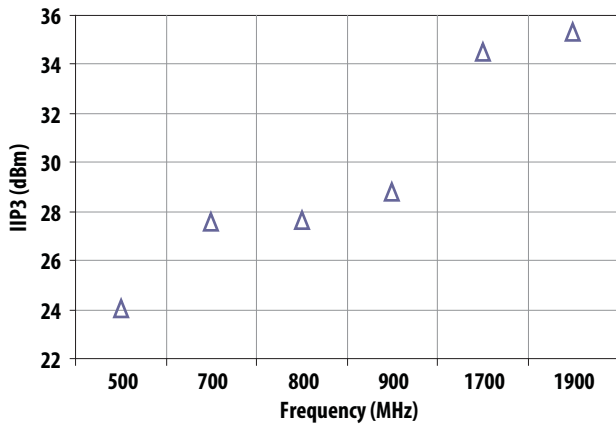

Figure 15. IIP3 vs Frequency for Optimum IIP3 and Fmin at 4.8 V 100 mA

Below is the table showing the MGA-636P8 Reflection Coefficient Parameters tuned for Maximum IIP3, Vdd = 4.8 V, Idd = 100 mA.

Frequency (GHz)	Gamma Load position		IIP3 (dBm)
	Magnitude	Angle	
0.50	0.36	-57.7	22.6
0.70	0.36	-57.6	28.4
0.80	0.36	-43.2	28.2
0.90	0.27	-39.9	28.9
1.70	0.27	-27.9	34.9
1.90	0.27	0.3	35.7

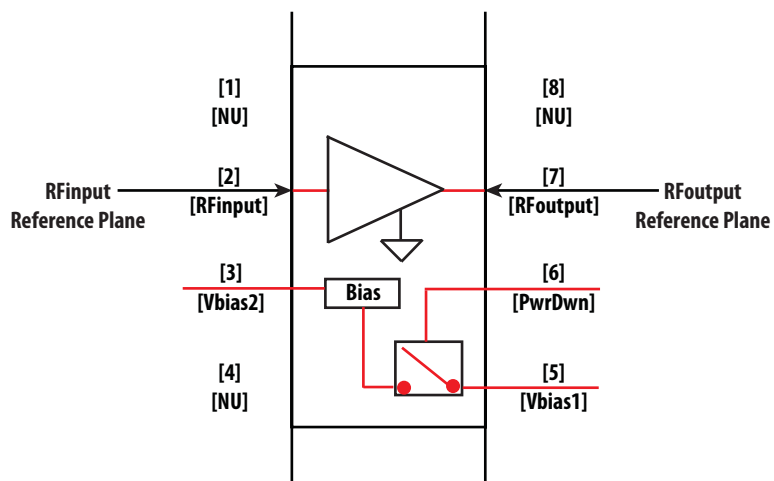

Figure 16. RFinput and RFoutput Reference Plane

Notes:

1. The Maximum IIP3 values are calculated based on Load pull measurements on approximately 100 different impedances using Focus Load pull test system.
2. Measurements are conducted on 0.010 inch thick ROGER 4350. The input reference plane is at the end of the RFin pin and the output reference plane is at the end of the RFout pin as shown in Figure 16.

## Typical Performance

RF performance at  $T_A = 25^\circ\text{C}$ ,  $V_{dd} = V_{bias1} = 4.8\text{ V}$ ,  $I_{dd} = 108\text{ mA}$ , LNA mode, measured on demo board in Figure 5. Signal = CW unless stated otherwise. Application Test Circuit is shown in Figure 6 and Table 1. IIP3 test condition:  $F_{RF1} - F_{RF2} = 1\text{ MHz}$  with input power of  $-10\text{ dBm}$  per tone.

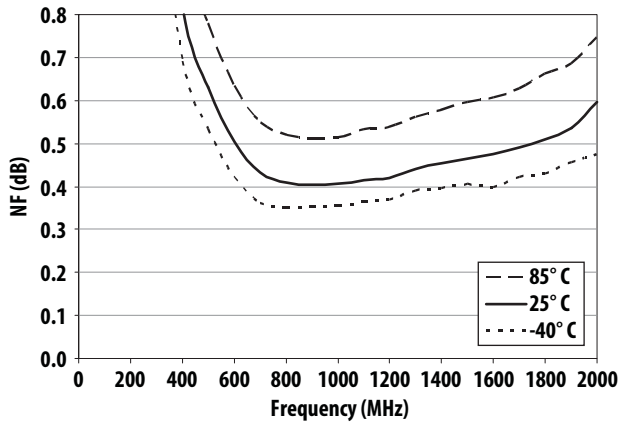

Figure 17. NF vs Frequency vs Temperature

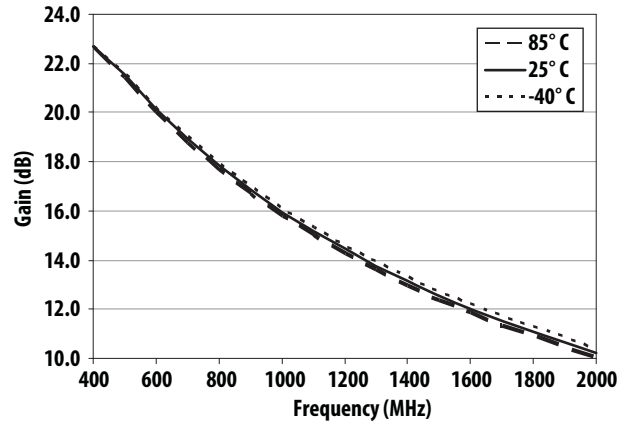

Figure 18. Gain vs Frequency vs Temperature

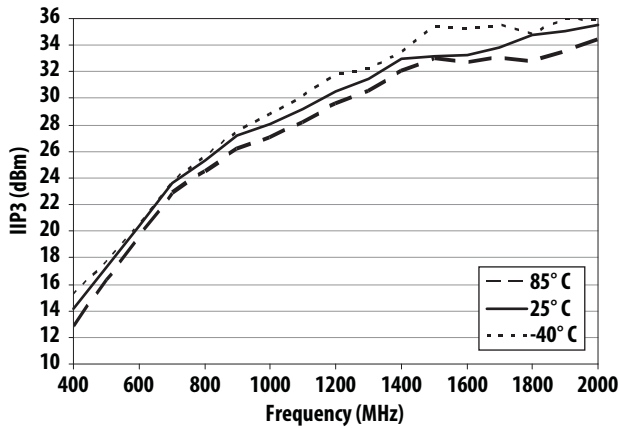

Figure 19. IIP3 vs Frequency vs Temperature

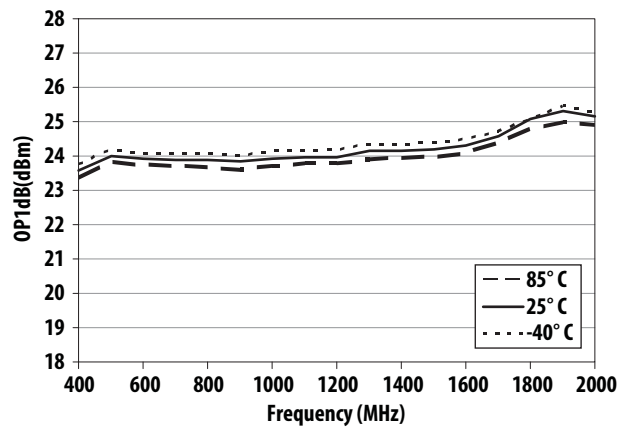

Figure 20. OP1dB vs Frequency vs Temperature



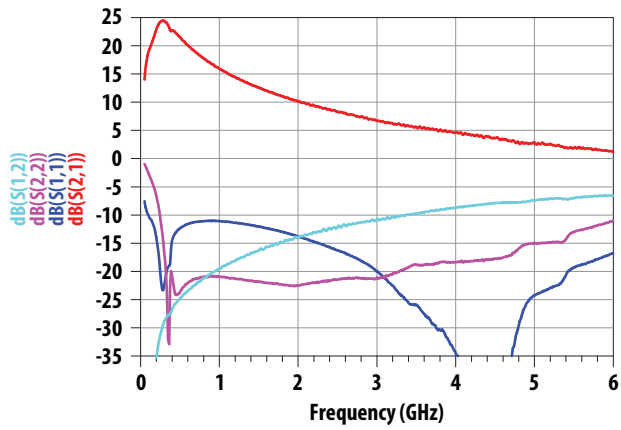

Figure 21. Input Return Loss, Output Return Loss, Gain, Reverse Isolation vs Frequency

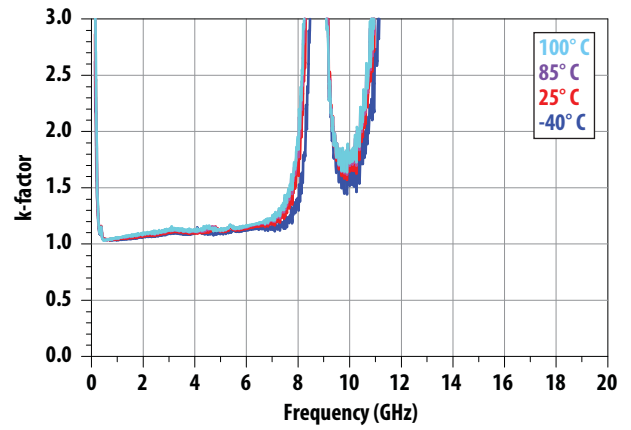

Figure 22. k-factor vs Frequency vs Temperature

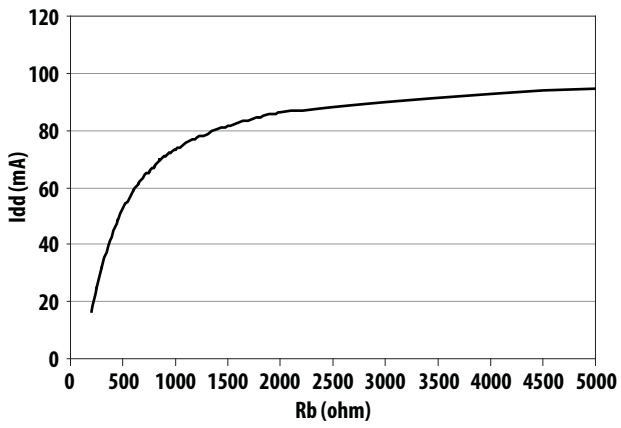

Figure 23.  $I_{dd}$  vs  $R_b$

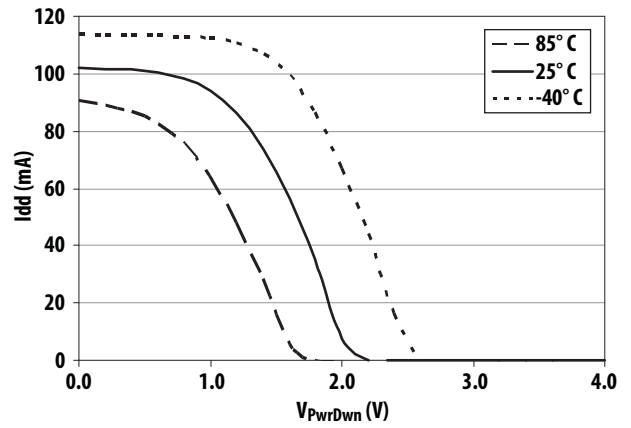

Figure 24.  $I_{dd}$  vs  $V_{pwrDwn}$

## Typical Scattering Parameters, Vdd = 4.8 V, Idd = 108 mA

### LNA SPAR (100 MHz – 20 GHz)

Freq (GHz)	S11 (dB)	S11 (ang)	S21 (dB)	S21 (ang)	S12 (dB)	S12 (ang)	S22 (dB)	S22 (ang)
0.1	-3.611	-62.842	30.561	136.999	-34.551	62.629	-15.454	-100.227
0.5	-10.75	-141.835	21.562	98.647	-25.1	65.794	-21.768	173.774
0.7	-11.393	-159.056	19.067	89.008	-22.486	65.115	-23.274	176.757
0.9	-11.693	-171.846	17.088	81.239	-20.477	63.144	-23.435	-175.622
1.0	-12.003	-176.697	16.247	77.798	-19.607	61.903	-24.023	-169.048
1.5	-12.658	161.534	12.916	62.727	-16.314	54.394	-22.335	-157.583
1.7	-12.53	154.197	11.855	57.342	-15.332	51.078	-20.648	-161.025
1.9	-12.404	147.907	10.906	52.163	-14.463	47.752	-19.362	-164.643
2.0	-12.379	145.023	10.472	49.657	-14.065	46.022	-18.873	-166.072
2.5	-12.524	132.944	8.569	37.635	-12.364	37.489	-17.143	-171.539
3	-13.356	123.107	7.083	26.504	-10.943	28.854	-15.991	-174.201
3.5	-14.336	114.678	5.844	15.468	-9.794	19.876	-15.602	-179.46
4	-15.464	103.233	4.756	5.444	-8.846	11.572	-14.891	177.251
4.5	-16.075	89.916	3.908	-5.273	-7.978	2.026	-13.836	161.01
5	-15.98	79.553	3.084	-15.148	-7.323	-6.929	-12.579	146.587
5.5	-15.742	62.755	2.344	-25.098	-6.757	-16.231	-11.308	133.363
6	-15.688	50.395	1.686	-34.558	-6.287	-25.298	-10.288	121.972
7	-17.293	40.867	0.539	-52.328	-5.474	-42.892	-9.2	104.475
8	-23.851	68.823	-0.256	-69.296	-4.831	-60.283	-9.074	95.197
9	-19.948	145.615	-1.09	-85.871	-4.478	-77.706	-9.337	88.367
10	-15.337	144.42	-1.671	-102.123	-4.108	-95.651	-8.526	78.112
11	-14.047	129.044	-2.544	-120.208	-4.249	-115.535	-7.598	48.997
12	-12.433	104.57	-3.529	-135.218	-4.696	-132.217	-6.371	28.359
13	-9.432	93.835	-4.488	-151.951	-5.197	-150.835	-4.998	26.293
14	-6.416	81.489	-5.847	-162.095	-6.312	-163.011	-5.407	16.024
15	-5.585	68.225	-5.445	-168.582	-5.676	-170.476	-8.272	15.731
16	-5.651	57.754	-5.184	172.519	-5.19	168.847	-6.291	6.112
17	-4.91	46.32	-6.704	156.563	-6.646	151.286	-4.337	-20.813
18	-4.432	34.876	-7.895	144.747	-7.778	138.297	-3.486	-31.185
19	-3.638	18.869	-8.76	131.758	-8.607	124.14	-2.747	-26.804
20	-3.147	2.127	-8.894	121.339	-8.745	112.553	-2.767	-18.826

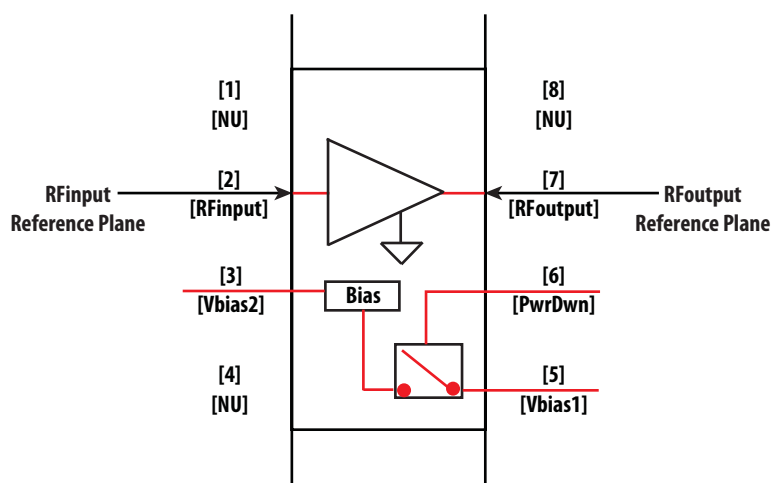

Figure 25. RFinput and RFoutput Reference Plane

### Typical Noise Parameters, V<sub>dd</sub> = 4.8 V, I<sub>dd</sub> = 108 mA

Freq GHz	F <sub>min</sub> dB	Γ <sub>opt</sub> Mag.	Γ <sub>opt</sub> Ang.	R <sub>n</sub> /50
0.5	0.472	0.078	-31.8	0.038
0.7	0.432	0.080	11.5	0.037
0.8	0.379	0.081	33.2	0.037
0.9	0.386	0.082	54.8	0.038
1.7	0.5	0.092	228	0.043
1.9	0.582	0.094	271	0.043

#### Notes:

1. The F<sub>min</sub> values are based on noise figure measurements at 100 different impedances using Focus source pull test system. From these measurements a true F<sub>min</sub> is calculated.
2. Scattering and noise parameters are measured on coplanar waveguide made on 0.010 inch thick ROGER 4350. The input reference plane is at the end of the RFin<sub>input</sub> pin and the output reference plane is at the end of the RFin<sub>output</sub> pin as shown in Figure 25.

### Part Number Ordering Information

Part Number	No. of Devices	Container
MGA-636P8-BLKG	100	Antistatic Bag
MGA-636P8-TR1G	3000	7 inch Reel

### DFN2X2 Package Dimensions

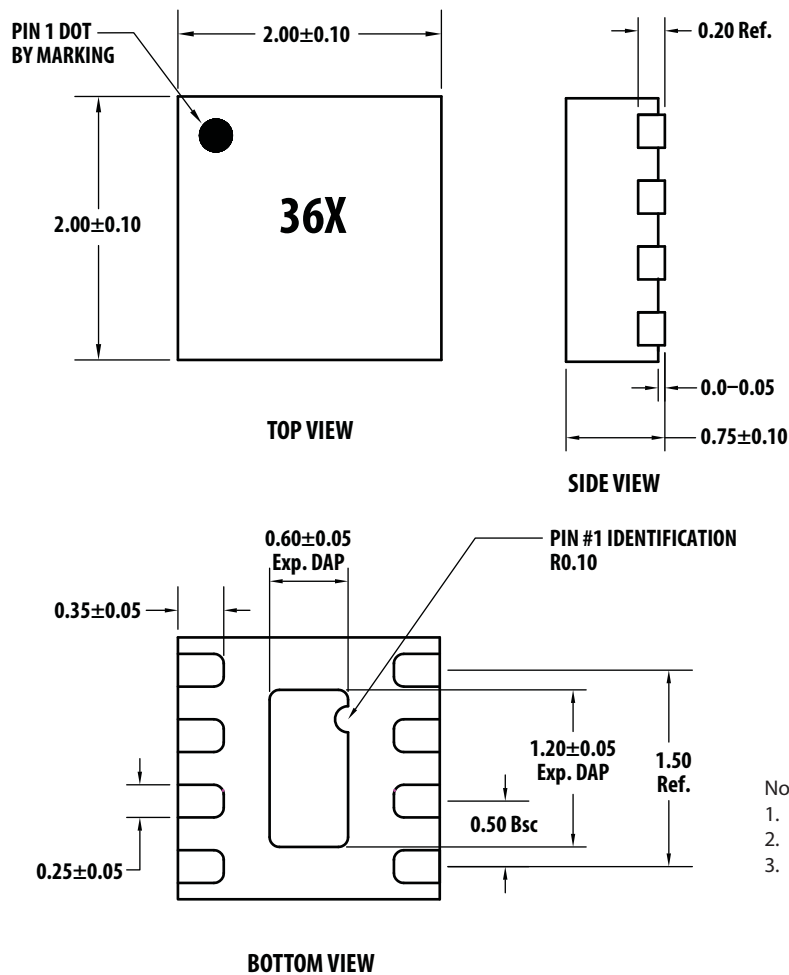

#### Notes:

1. All dimensions are in millimeters.
2. Dimensions are inclusive of plating.
3. Dimensions are exclusive of mold ash and metal burr.



## Device Orientation

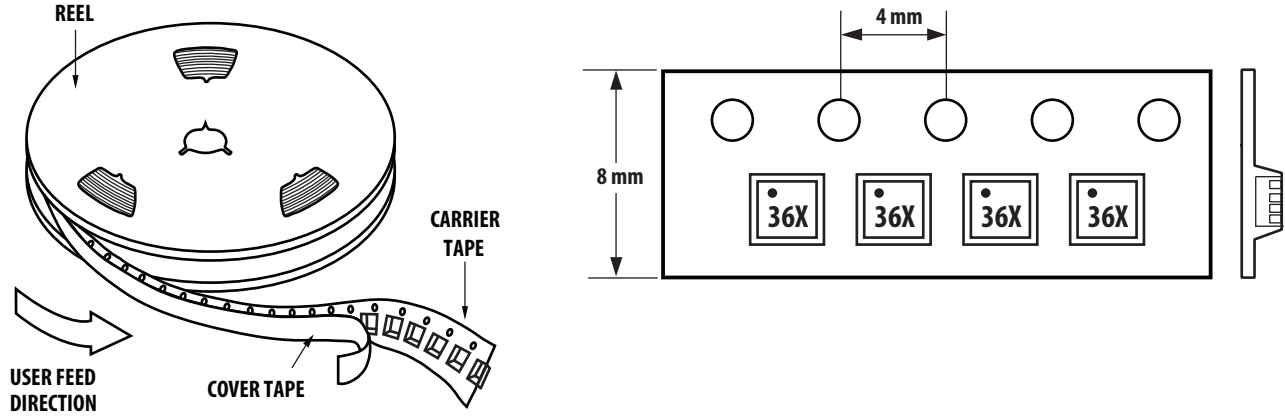

## Tape Dimensions

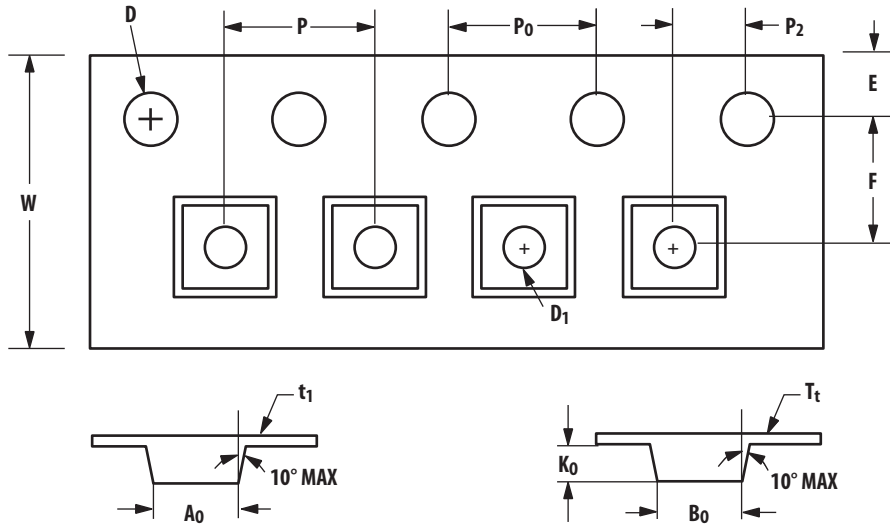

	DESCRIPTION	SYMBOL	SIZE (mm)	SIZE (INCHES)
CAVITY	LENGTH	$A_0$	$2.30 \pm 0.05$	$0.091 \pm 0.004$
	WIDTH	$B_0$	$2.30 \pm 0.05$	$0.091 \pm 0.004$
	DEPTH	$K_0$	$1.00 \pm 0.05$	$0.039 \pm 0.002$
	PITCH	$P$	$4.00 \pm 0.10$	$0.157 \pm 0.004$
	BOTTOM HOLE DIAMETER	$D_1$	$1.00 + 0.25$	$0.039 + 0.002$
	PERFORATION	DIAMETER	$D$	$1.50 \pm 0.10$
PITCH		$P_0$	$4.00 \pm 0.10$	$0.157 \pm 0.004$
POSITION		$E$	$1.75 \pm 0.10$	$0.069 \pm 0.004$
		$F$	$3.50 \pm 0.05$	$0.138 \pm 0.002$
CARRIER TAPE	WIDTH	$W$	$8.00 \pm 0.30$	$0.315 \pm 0.012$
	THICKNESS	$t_1$	$0.254 \pm 0.02$	$0.010 \pm 0.0008$
COVER TAPE	WIDTH	$C$	$5.4 \pm 0.10$	$0.205 \pm 0.004$
	TAPE THICKNESS	$T_t$	$0.062 \pm 0.001$	$0.0025 \pm 0.0004$
DISTANCE	CAVITY TO PERFORATION (WIDTH DIRECTION)	$F$	$3.50 \pm 0.05$	$0.138 \pm 0.002$
	CAVITY TO PERFORATION (LENGTH DIRECTION)	$P_2$	$2.00 \pm 0.05$	$0.079 \pm 0.002$

# Reel Dimensions – 7 inch

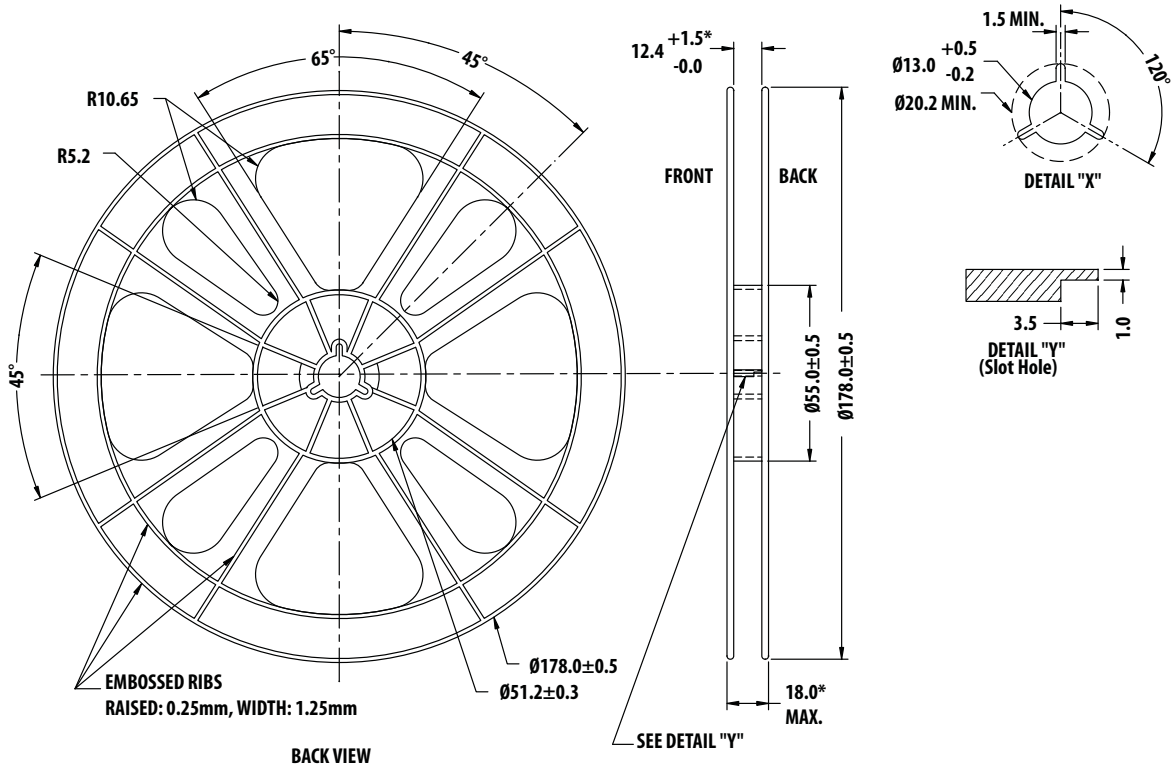
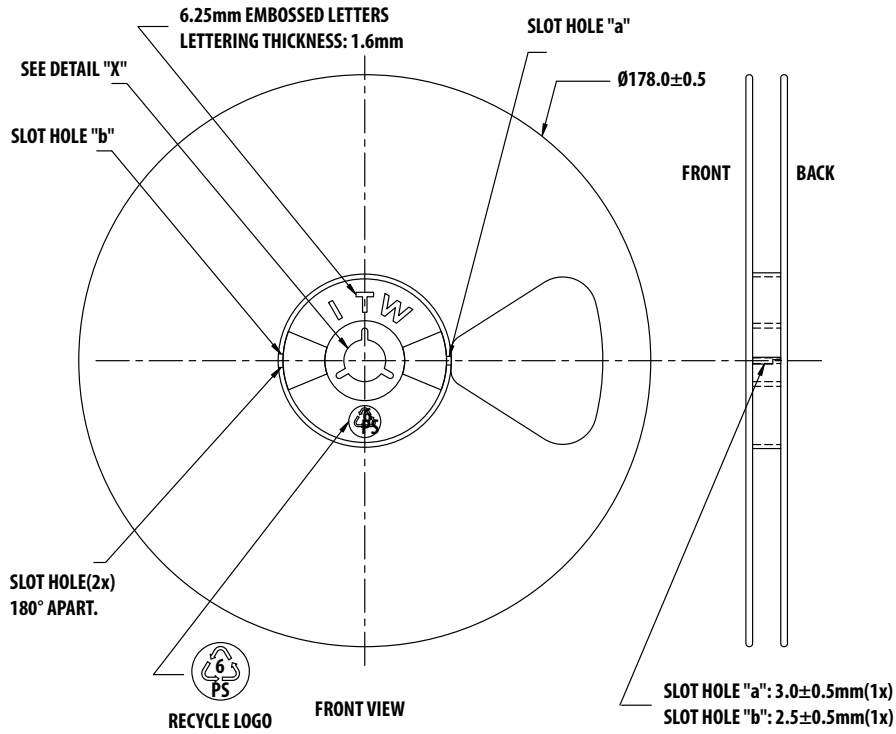

For product information and a complete list of distributors, please go to our web site: [www.avagotech.com](http://www.avagotech.com)

Avago, Avago Technologies, and the A logo are trademarks of Avago Technologies in the United States and other countries. Data subject to change. Copyright © 2005-2011 Avago Technologies. All rights reserved. AV02-2991EN - September 29, 2011

