

MICRO ELECTRONICS

MGB51C
MGB51D
MGB51T
MGB51W

GREEN LED LAMPS

DESCRIPTION

MGB51 Series are green LED lamp with 5mm diameter epoxy package.

MGB51C is green chip with green transparent lens.

MGB51D is green chip with green diffused lens.

MGB51T is green chip with clear transparent lens.

MGB51W is green chip with clear diffused lens.

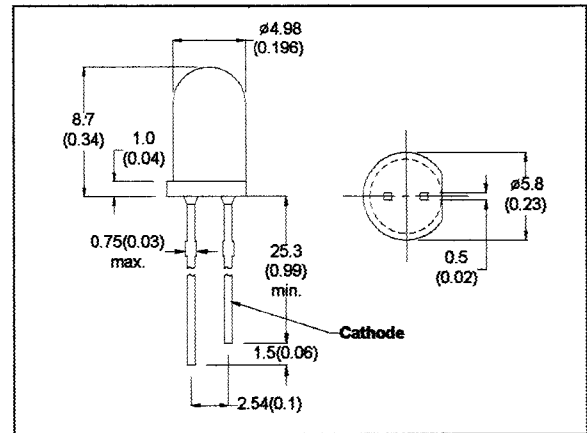

- All Dimension in mm (inch)
- No Scale
- Tol : +/- 0.3mm

ABSOLUTE MAXIMUM RATINGS

Power Dissipation @ $T_a=25^\circ\text{C}$

90mW

Forward Current, DC (IF)

30mA

Reverse Voltage

5V

Operating & Storage Temperature Range

-55 to +100°C

Lead Soldering Temperature (1/16" from body)

260°C for 5 sec.

ELECTRO-OPTICAL CHARACTERISTICS (Ta=25°C)

PARAMETER	SYMBOL	MGB51C	MGB51D	MGB51T	MGB51W	UNIT	CONDITIONS
Forward Voltage	MAX VF	3.0	3.0	3.0	3.0	V	IF=20mA
Reverse Breakdown Voltage	MIN BVR	5	5	5	5	V	IR=100 μ A
Luminous Intensity	MIN IV	100	40	100	40	mcd	IF=20mA
	TYP	180	70	180	70	mcd	
Peak Wavelength	TYP λ_p	570	570	570	570	nm	IF=20mA
Spectral Line Half Width	TYP $\Delta\lambda$	30	30	30	30	nm	IF=20mA

MICRO ELECTRONICS LTD.

38, Hung To Road, Microtron Building, Kwun Tong, Kowloon, Hong Kong.

Kwun Tong P.O. Box 69477 Hong Kong. Fax No. 2341 0321 Telex:43510 Micro Hx. Tel: 2343 0181-5

Rev.A.

Page 1 of 2

Sep-99

MGB51D

