



Obsolescence Notice

This product is obsolete.

This information is available for your convenience only.

For more information on Zarlink's obsolete products and replacement product lists, please visit http://products.zarlink.com/obsolete_products/

Features

- Dual RF Ports for 900MHz and 1900MHz
- AGC Amplifier with 90dB of Variable Gain, Fully Compensated for Temperature
- On-chip Active Filter. Removes the Requirement for External IF SAW Filter
- High Power 900MHz and 1900MHz Output Stages
- Quadrature Modulator

Applications

- Transmit Modulator and Up-converter in TDMA/AMPS Mobile Phones

Absolute Maximum Ratings

Supply voltage (V _{CC})	4V
Control input voltage	-0.6V to V _{CC} + 0.6V
Storage temperature, T _{STG}	-55°C to +125°C
Operating temperature	-40°C to 100°C
Max Junction Temperature (T _J)	150°C

DS5241

ISSUE 3.0

December 2000

Ordering Information

MGCT02/KG/QP1S
MGCT02/KG/QP1T

The MGCT02 circuit is designed for use in dual band, dual mode cellular 900MHz/PCS1900MHz mobile phones. It can be used for TDMA/AMPS. The MGCT02 is compatible with baseband and mixed signal interface circuits from Zarlink Semiconductor and other manufacturers.

System costs have been kept to a minimum by removing the requirement for an additional SAW filter in the transmit IF path. The AGC has been split between RF and IF sections to reduce noise and a low pass filter has been included before the IF variable gain amplifier to remove spurious products produced in the modulator.

For CDMA systems the MGCT04 is recommended.

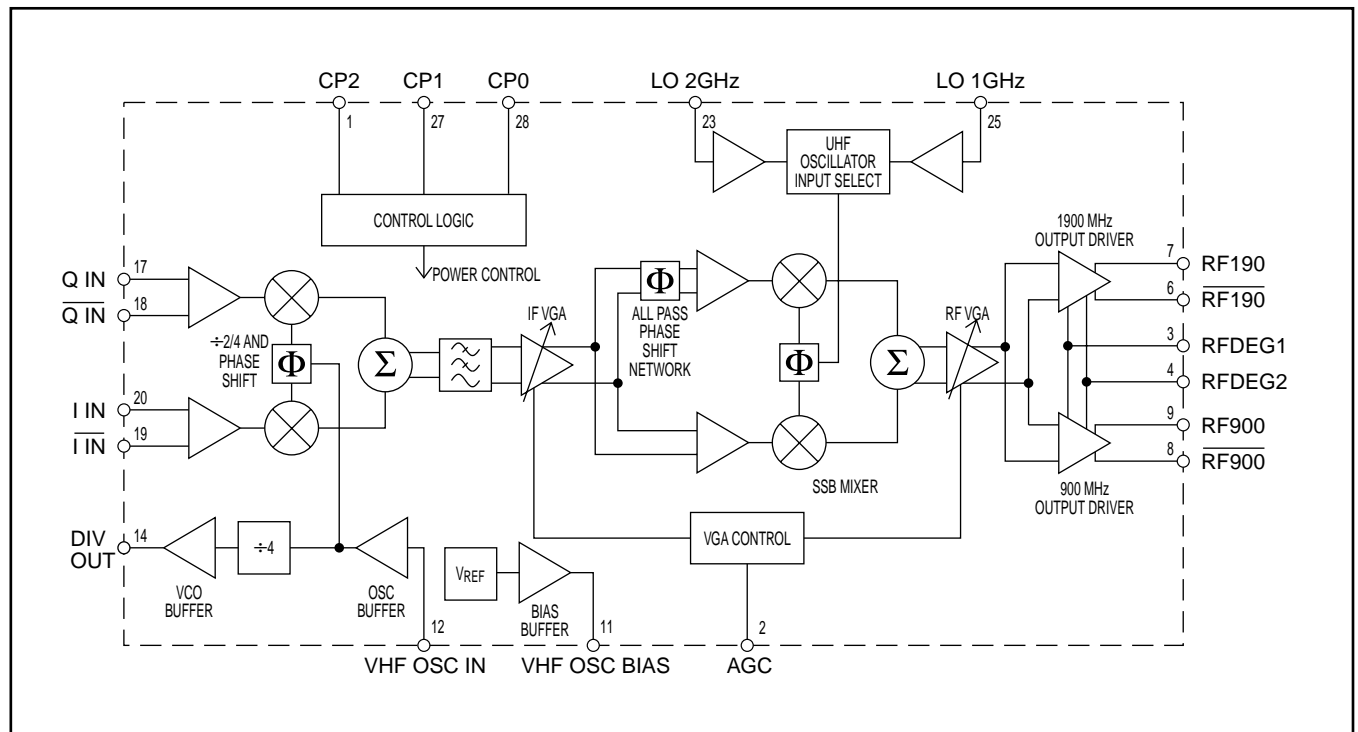

Figure 1 - MGCT02 Block Diagram

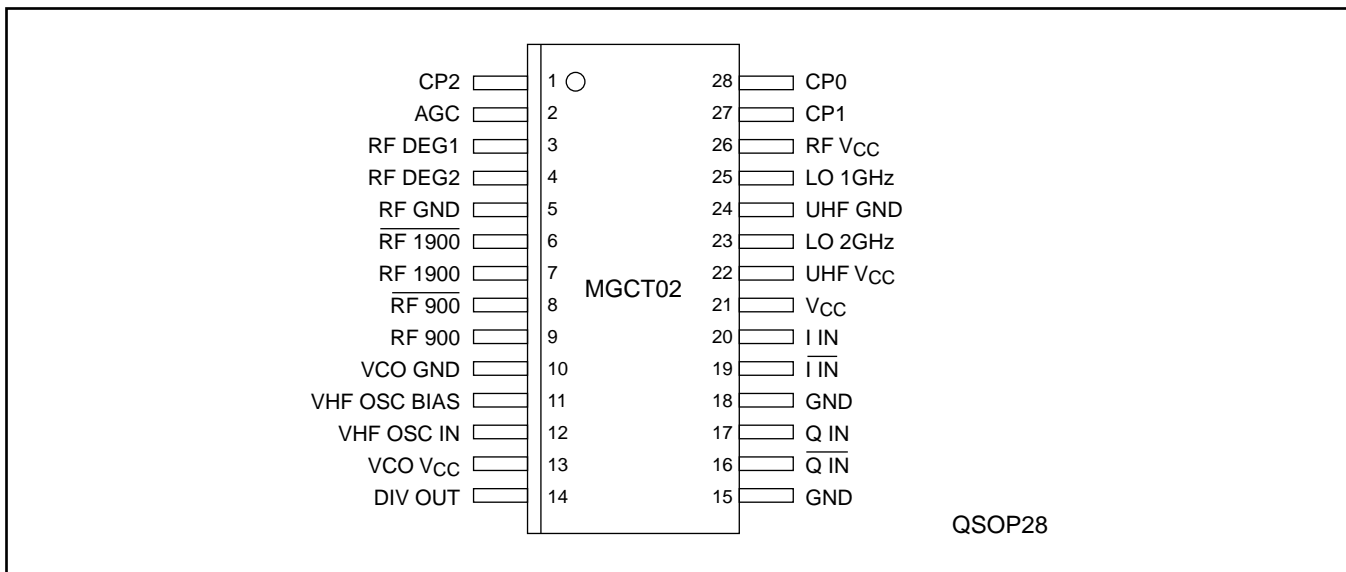

Figure 2 - Pin Connections - top view

Pin	Signal Name	Function
1	CP2	Control pin 2. See Tables 4 and 5 for function
2	AGC	Control voltage for IF and RF variable gain amplifiers
3	RF DEG1	Connection to external inductor to control gain of power amplifiers
4	RF DEG2	Connection to external inductor to control gain of power amplifiers
5	RF GND	Ground connection to RF circuits
6	$\overline{\text{RF 1900}}$	Inverse output from 1900MHz differential output driver
7	RF1900	Output from 1900MHz differential output driver
8	$\overline{\text{RF 900}}$	Inverse output from 900MHz differential output driver
9	RF 900	Output from 900MHz differential output driver
10	VCO GND	Ground connection for VHF oscillator
11	VHF OSC BIAS	Switched bias voltage for external VHF oscillator
12	VHF OSC IN	Input from external VHF oscillator
13	VCO Vcc	Positive supply to VHF oscillator
14	DIV OUT	Output from VHF oscillator divided by 4
15	GND	Ground connection
16	$\overline{\text{Q IN}}$	$\overline{\text{Q}}$ input
17	Q IN	Q input
18	GND	Ground connection
19	$\overline{\text{I IN}}$	$\overline{\text{I}}$ input
20	I IN	I input
21	Vcc	Positive supply connection
22	UHF Vcc	Positive supply to UHF oscillator input buffers
23	LO 2GHZ	2GHz local oscillator input
24	GND UHF	Ground connection to UHF oscillator input buffers
25	LO 1GHZ	1GHz local oscillator input
26	RF Vcc	Positive supply connection to RF circuits
27	CP1	Control pin 1. See Tables 4 and 5 for function
28	CP0	Control pin 0. See Tables 4 and 5 for function

Table 1 - Pin Assignments

Electrical Characteristics

Test conditions (unless otherwise stated): $T_{amb} = -30^{\circ}\text{C}$ to $+70^{\circ}\text{C}$, $V_{CC} = 2.7\text{V}$ to 3.6V . UHF LO level = -15dBm (both bands), I, Q input = 1.4 volts p.p, test frequency = 849MHz (900 output) and 1910MHz (1900 output). These characteristics are guaranteed by either production test or design. They apply within the specified ambient temperature and supply voltage ranges unless otherwise stated.

Characteristics	Value			Units	Conditions
	Min.	Typ.	Max.		
Supply current					
Sleep current			75	μA	All circuits off
Standby mode supply current		8	10	mA	See Tables 4 and 5
Total supply current		118	152	mA	Maximum power PCS mode
Standby to operating mode switching time			10	μs	
Logic inputs					
Logic high voltage	$V_{CC}-0.6$		V_{CC}	V	
Logic low voltage	0		0.8	V	

Table 2 - DC Characteristics

Characteristics	Value			Units	Conditions
	Min.	Typ.	Max.		
I and Q modulator					
I and Q input voltage level	1.0	1.4	2.0	V_{pp}	Differential
I and Q common mode voltage		1.2		V	
I and Q differential input resistance	13.5			$\text{k}\Omega$	
I and Q input bandwidth	2.5			MHz	
IF Vector offset	30			dB	
SSB rejection	30			dB	
VHF oscillator input and divider					
Input drive level	22	40	70	mV_{rms}	From external VHF osc. via matching network
VHF oscillator bias voltage		1.2		V	
Output level from prescaler	400			mV_{pp}	6pF load
Prescaler divide ratio		4			Drive output for synthesiser
Variable gain amplifiers					
IF amp. operating frequency range	50		200	MHz	VGA=0.5 to 2.6V
RF amp. operating frequency range	750		2000	MHz	
Gain control range	60			dB	
Control voltage for minimum gain	0.1			V	
Control voltage for maximum gain			2.6	V	
AGC control voltage slope	33		60	dB/V	

Table 3 - AC Characteristics

Characteristics	Value			Units	Conditions
	Min.	Typ.	Max.		
SSB mixer and UHF oscillator inputs					
SSB rejection	18			dB	
Cellular band LO input level	-15	-10	-5	dBm	From external UHF osc. via matching network
PCS band LO input level	-15	-10	-5	dBm	From external UHF osc. via matching network
Cellular band local oscillator input frequency. (LO 1GHz)	850		1100	MHz	
PCS band local oscillator input frequency (LO 2GHz)	1500		2150	MHz	
900MHz RF output stage					
Specifications assume 50 ohm load driven via a matching network (Fig. 6)					
RF amplifier operating frequency range	824		849	MHz	
Output power	+8		+19	dBm	Note 1
ACPR (TDMA)	-45		-30	dBc	Pout = +8dBm, Offset = 30kHz
	-90		-60	dBc	Pout = +8dBm, Offset = 60kHz
Output power AMPS	+10	+14	+19	dBm	Note 2
Receive band noise (869 - 894MHz)		-123	-121	dBm/Hz	ftx = 849 MHz Pout = +8dBm
Spurious Outputs					
LO Leakage			-18	dBc	Note 2, Pout = +8dBm
LO Leakage			-14	dBm	Vcc = 3V, T = 25°C Pout = +8dBm
Image Rejection			-18	dBc	Note 2, Pout = +8dBm
Other Spurii			-20	dBm	Note 3
1900MHz RF output stage (PCS)					
Specifications assume 50 ohm load driven via a matching network (Fig. 5)					
RF amplifier operating frequency range	1850		1910	MHz	
Output power	+8		+18	dBm	Note 1
ACPR (TDMA)	-45		-30	dBc	Pout = +8dBm, Offset = 30kHz
	-90		-60	dBc	Pout = +8dBm, Offset = 60kHz
Receive band noise (1930 - 1990 MHz)		-123	-121	dBm/Hz	ftx = 1910MHz, Pout = +8dBm
Receive band noise (1930 - 1990MHz)		-128	-125	dBm/Hz	ftx = 1910MHz, Pout = +3dBm Vcc = 3V, T = 25°C

Table 3 - AC Characteristics (continued)

Characteristics	Value			Units	Conditions
	Min.	Typ.	Max.		
Spurious Outputs					
LO Leakage			-18	dBc	Note 2, Pout = -8dBm
LO Leakage			-14	dBm	Vcc = 3V, T = 25°C Pout = +8dBm
Image Rejection			-18	dBc	Note 2, Pout = +8dBm
Other Spurii			-20	dBm	Note 3

Table 3 - AC Characteristics (continued)

Notes:

1. V (I/Q) = 1.4V differential, VHF LO = 22mV rms, UHF LO = -15dBm, VGA = 2.6volts
2. V (I/Q) = 1.4 V dc differential, VHF LO = 22mV rms, UHF LO = -15dBm
3. Frequency range 10MHz to 10*ftx except Rx and Tx bands

Circuit Description

General

The MGCT02 circuit is designed to provide the transmit function in dual band dual mode IS136/AMPS mobile phones. The circuit contains the following blocks:

1. Quadrature modulator
2. VHF voltage controlled oscillator buffer and divide by 4 prescaler
3. Active IF low pass filter
4. IF variable gain amplifier
5. Single sideband mixer with external UHF oscillator inputs
6. RF variable gain amplifier
7. 900MHz and 1900MHz high power output driver stages
8. Power and mode control logic

Quadrature Modulator

I and Q data from a baseband circuit such as the Zarlink Semiconductor MGCM01 or MGCM02 circuit is applied to the I and Q inputs of the quadrature modulator to produce the intermediate frequency by mixing with the local oscillator frequency from the

VHF VCO. The control inputs can select either a divide by two or divide by four function between the VHF VCO and the quadrature modulator giving a choice of possible intermediate frequencies.

VHF Oscillator Input Oscillator Bias and Divider

An external VHF oscillator circuit is AC coupled to the VHF oscillator input. The oscillator drives the quadrature modulator and an internal divide by four circuit to reduce the frequency of the output signal to be sent off chip to the frequency synthesiser. This reduces the power required in the output buffer circuit and also allows a low frequency low power CMOS synthesiser to be used. An oscillator bias circuit is included on the chip so that the external VHF oscillator transistor can be switched off using the control inputs. The bias voltage is switched off in either of the sleep conditions shown in Tables 4 and 5.

Active Low Pass Filter

The output from the quadrature modulator is passed to the active low pass filter which attenuates wide band noise and spurious outputs.

IF Variable Gain Amplifier

The filtered IF signal is passed to the IF variable gain amplifier which in turn drives the single sideband mixer. An externally applied AGC control voltage allows the total circuit gain to be varied.

The AGC action is split between the IF and RF portions of the circuit and an internal AGC control circuit processes the external AGC control voltage to drive both IF and RF variable gain amplifiers and provides a near linear control characteristic over the entire AGC range.

Single Sideband Mixer

The modulated IF signal is fed to the single sideband mixer which up-converts the IF to the RF frequency to be transmitted by mixing with an RF signal from one of two external UHF oscillator input pins, selected by an on chip multiplexer. When 1900MHz mode is programmed with the VHF oscillator in divide by four mode (Tables 4 and 5), the polarity of the quadrature oscillator drive signals to the single sideband mixer are reversed, thus selecting a low side LO for 1900MHz PCS and high side for 900MHz. This technique allows a common IF and filter to be used for both 900MHz and 1900MHz bands.

RF Variable Gain Amplifier

The SSB mixer is followed by the RF variable gain amplifier stage which provides about 23dB of the total gain variation. An additional SAW filter in the

transmit path is avoided by providing the gain variation after the mixer.

The variable gain amplifier control circuit ensures that the attenuation from maximum power is initially controlled by the RF variable gain stage thus reducing the noise contribution from the RF mixer.

Output Drivers

Separate output drive stages are provided for 900MHz and 1900MHz operation. A differential design is used for both amplifiers to improve power efficiency and to ease power supply decoupling problems. The 900MHz output stage provides a linear output of 8dBm for TDMA operation, but is over-driven in AMPS mode to obtain a typical output of 11dBm. In both power driver stages the DC current is backed off as the RF and IF gain is reduced, improving efficiency when less than maximum output power is required.

Control Inputs

Three control inputs are provided to select different operating modes for the chip; the various modes selected by the control pins are shown in Tables 4 and 5.

CP2	CP1	CP0	Function
0	0	0	Sleep mode. All circuits powered down
0	0	1	Quadrature modulator on. 1900MHz mode. Low side UHF LO. IF = VHF VCO ÷ 4
0	1	0	Quadrature modulator on. 900MHz mode. high side UHF LO. IF = VHF VCO ÷ 4
0	1	1	Standby mode. VHF oscillator input buffer, oscillator bias and divider on. All other circuits powered down

Table 4 - Control pin functions; VHF LO in divide-by-four mode

CP2	CP1	CP0	Function
1	0	0	Sleep mode. All circuits powered down
1	0	1	Quadrature modulator on. 1900MHz mode. Low side UHF LO. IF = VHF VCO ÷ 2
1	1	0	Quadrature modulator on. 900MHz mode. high side UHF LO. IF = VHF VCO ÷ 2
1	1	1	Standby mode. VHF oscillator input buffer, oscillator bias and divider on. All other circuits powered down

Table 5 - Control pin functions; VHF LO in divide-by-two mode

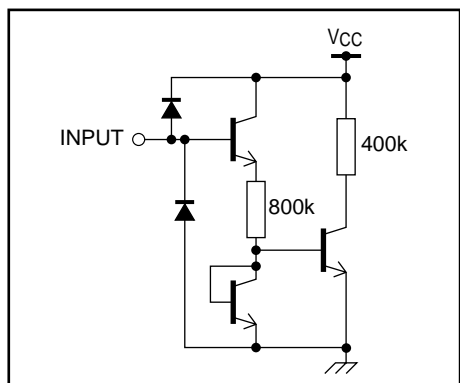

Figure 3a - Control inputs CP0, CP1 and CP2

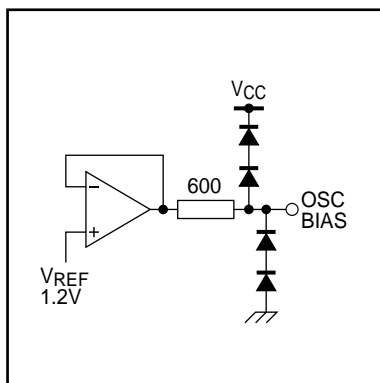

Figure 3b - Oscillator bias buffer

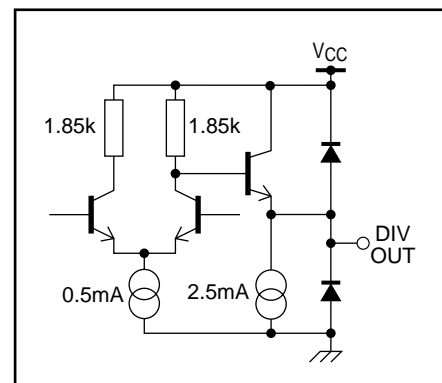

Figure 3c - Divider output circuit

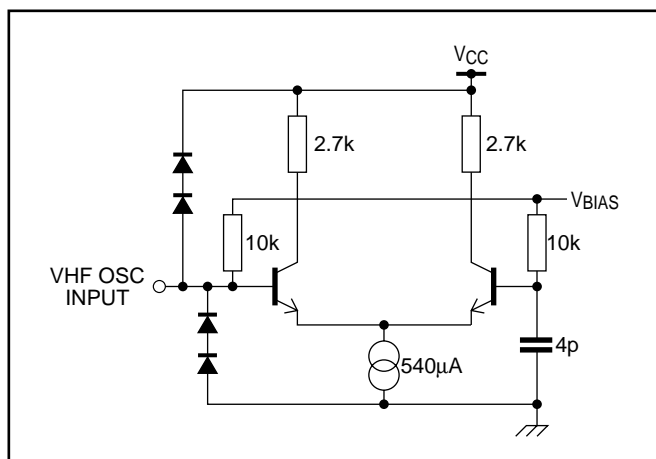

Figure 3d - VHF oscillator input buffer

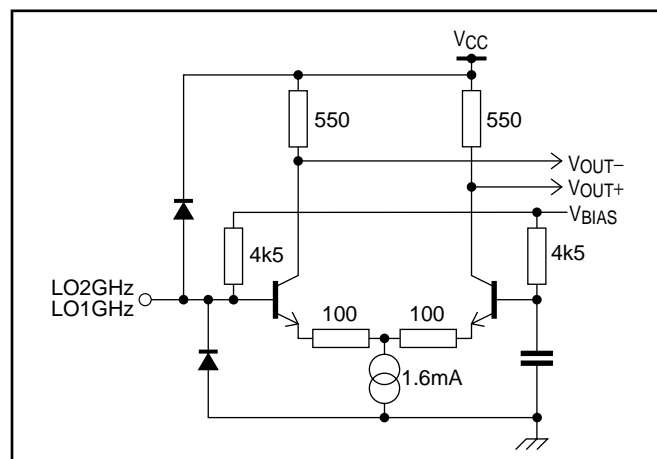

Figure 3e - LO2GHz and LO1GHz oscillator inputs

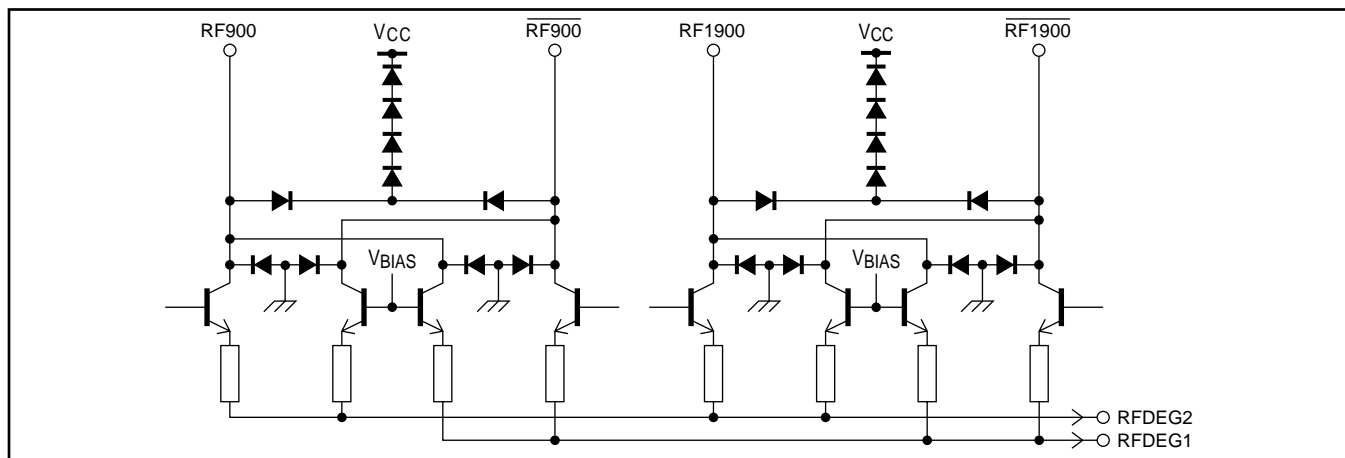

Figure 3f - 900MHz and 1900MHz outputs

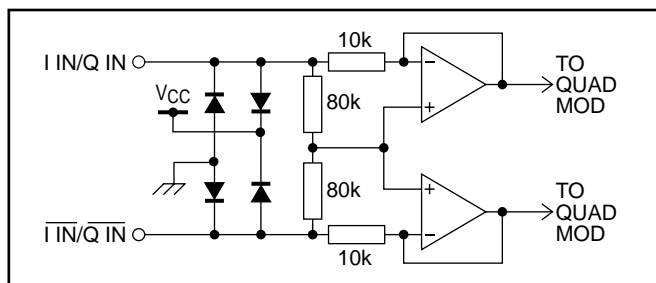

Figure 3g - I and Q inputs

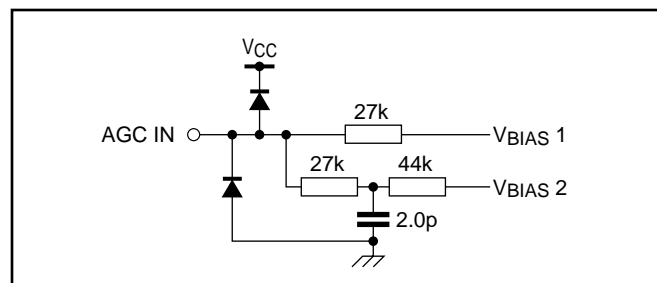

Figure 3h - AGC input

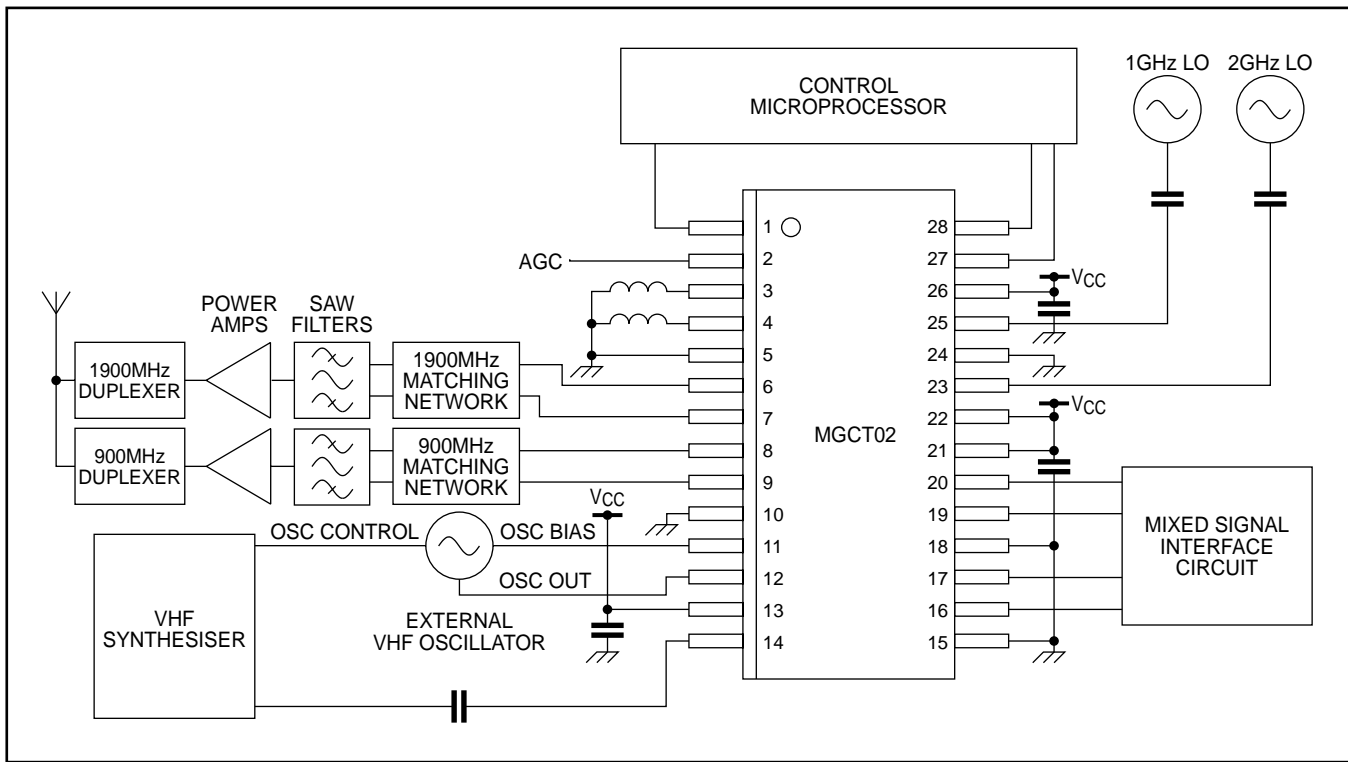

Figure 4 - Typical application circuit

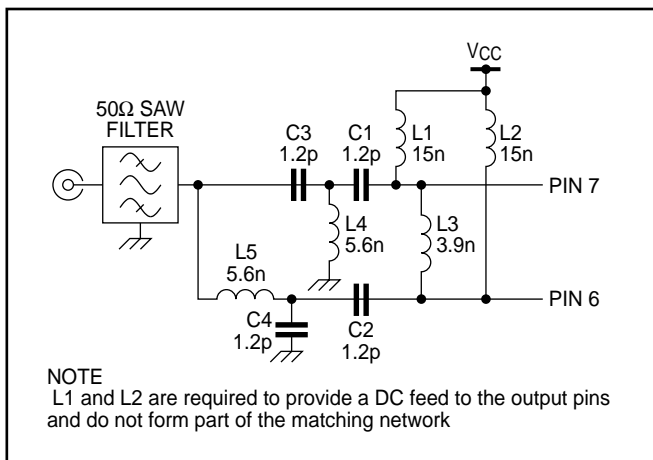

Figure 5 - Typical 1900MHz output matching network

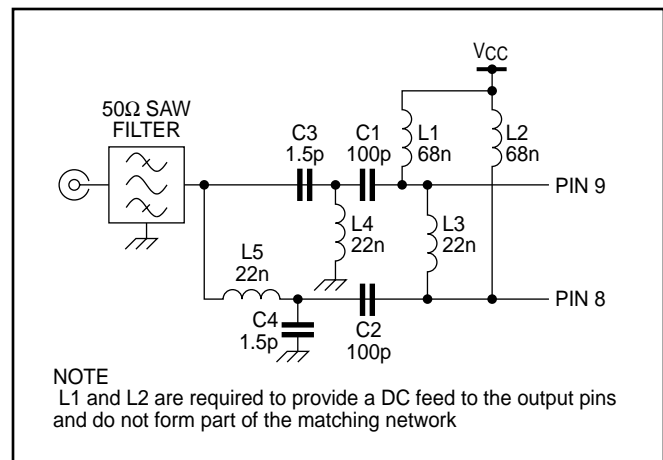

Figure 6 - Typical 900MHz output matching network

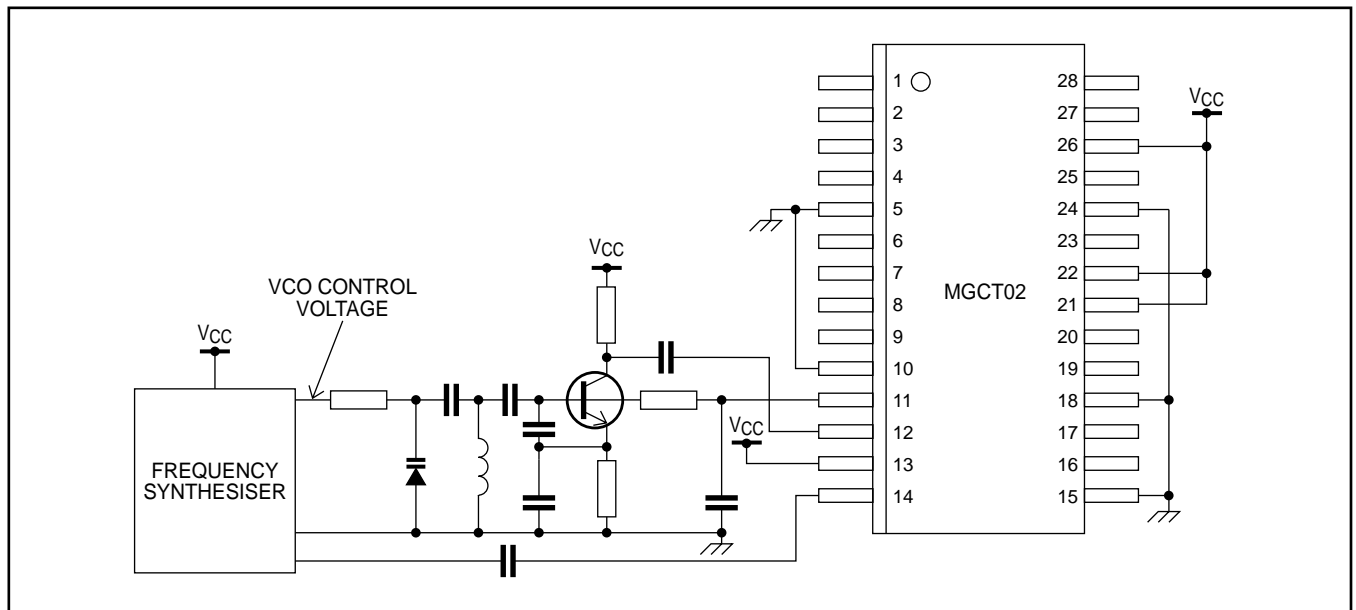

Figure 7 - Typical circuit showing connection of external VHF oscillator

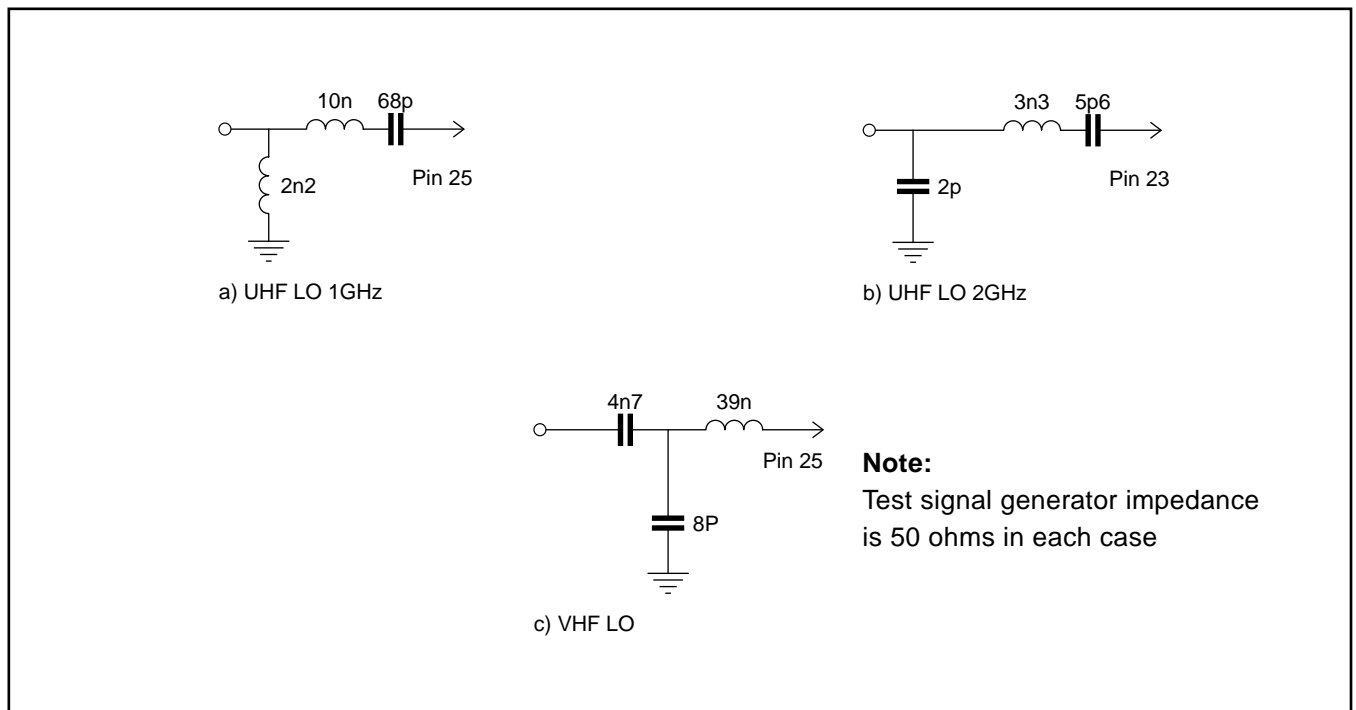
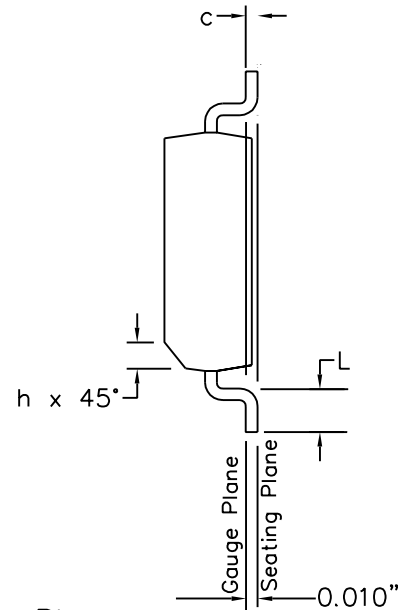
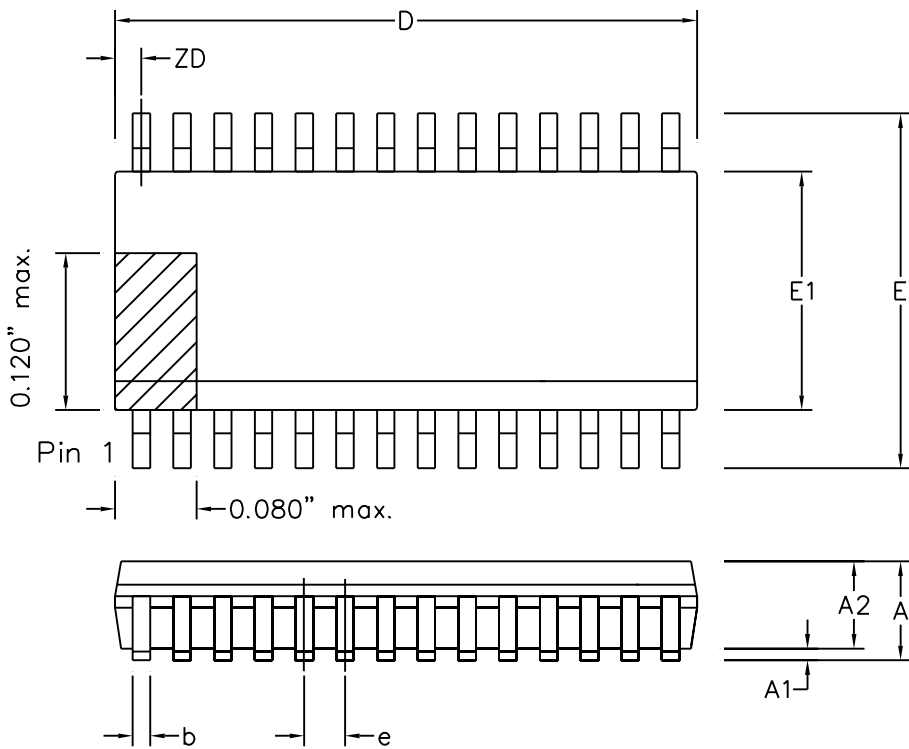

Figure 8 - LO Input Test Circuits



Symbol	Control Dimensions in inches		Altern. Dimensions in millimetres	
	MIN	MAX	MIN	MAX
A	0.053	0.069	1.35	1.75
A1	0.004	0.010	0.10	0.25
A2	—	0.059	—	1.50
D	0.386	0.394	9.80	10.01
ZD	0.033	REF.	0.84	REF.
E	0.228	0.244	5.79	6.20
E1	0.150	0.157	3.81	3.99
L	0.016	0.050	0.41	1.27
e	0.025	BSC.	0.64	BSC.
b	0.008	0.012	0.20	0.30
c	0.007	0.010	0.18	0.25
θ	0°	8°	0°	8°
h	0.010	0.020	0.25	0.50
Pin features				
N	28			
Conforms to JEDEC MO-137AF Iss. A				

This drawing supersedes
418/ED/51617/004 (Swindon/Plymouth)

Notes:

1. The chamfer on the body is optional. If it is not present, a visual index feature, e.g. a dot, must be located within the cross-hatched area.
2. Controlling dimensions are in inches.
3. Dimension D do not include mould flash, protrusion or gate burrs. These shall not exceed 0.006" per side.
4. Dimension E1 do not include inter-lead flash or protrusion. These shall not exceed 0.010" per side.
5. Dimension b does not include dambar protrusion/intrusion. Allowable dambar protrusion shall be 0.004" total in excess of b dimension.

© Zarlink Semiconductor 2002 All rights reserved.				
ISSUE	1	2	3	
ACN	201930	207316	212476	
DATE	27Feb97	24Aug99	3Apr02	
APPRD.				



Previous package codes	QP / Q
------------------------	--------

Package Code	DG
Package Outline for 28 lead QSOP (0.150" Body Width)	
GPD00292	



**For more information about all Zarlink products
visit our Web Site at
www.zarlink.com**

Information relating to products and services furnished herein by Zarlink Semiconductor Inc. or its subsidiaries (collectively "Zarlink") is believed to be reliable. However, Zarlink assumes no liability for errors that may appear in this publication, or for liability otherwise arising from the application or use of any such information, product or service or for any infringement of patents or other intellectual property rights owned by third parties which may result from such application or use. Neither the supply of such information or purchase of product or service conveys any license, either express or implied, under patents or other intellectual property rights owned by Zarlink or licensed from third parties by Zarlink, whatsoever. Purchasers of products are also hereby notified that the use of product in certain ways or in combination with Zarlink, or non-Zarlink furnished goods or services may infringe patents or other intellectual property rights owned by Zarlink.

This publication is issued to provide information only and (unless agreed by Zarlink in writing) may not be used, applied or reproduced for any purpose nor form part of any order or contract nor to be regarded as a representation relating to the products or services concerned. The products, their specifications, services and other information appearing in this publication are subject to change by Zarlink without notice. No warranty or guarantee express or implied is made regarding the capability, performance or suitability of any product or service. Information concerning possible methods of use is provided as a guide only and does not constitute any guarantee that such methods of use will be satisfactory in a specific piece of equipment. It is the user's responsibility to fully determine the performance and suitability of any equipment using such information and to ensure that any publication or data used is up to date and has not been superseded. Manufacturing does not necessarily include testing of all functions or parameters. These products are not suitable for use in any medical products whose failure to perform may result in significant injury or death to the user. All products and materials are sold and services provided subject to Zarlink's conditions of sale which are available on request.

Purchase of Zarlink's I²C components conveys a licence under the Philips I²C Patent rights to use these components in and I²C System, provided that the system conforms to the I²C Standard Specification as defined by Philips.

Zarlink, ZL and the Zarlink Semiconductor logo are trademarks of Zarlink Semiconductor Inc.

Copyright Zarlink Semiconductor Inc. All Rights Reserved.

TECHNICAL DOCUMENTATION - NOT FOR RESALE
