

MGFC36V3436

3.4 - 3.6GHz BAND 4W INTERNALLY MATCHED GaAs FET

DESCRIPTION

The MGFC36V3436 is an internally impedance-matched GaAs power FET especially designed for use in 3.4 - 3.6 GHz band amplifiers. The hermetically sealed metal-ceramic package guarantees high reliability.

FEATURES

- Class A operation
- Internally matched to 50(ohm) system
- High output power
P1dB = 4W (TYP.) @ f=3.4 - 3.6 GHz
- High power gain
GLP = 12 dB (TYP.) @ f=3.4 - 3.6GHz
- High power added efficiency
P.A.E. = 32 % (TYP.) @ f=3.4 - 3.6GHz
- Low distortion [item -51]
IM3=-45dBc(Typ.) @Po=25dBm S.C.L.

APPLICATION

- item 01 : 3.4 - 3.6 GHz band power amplifier
- item 51 : 3.4 - 3.6 GHz band digital radio communication

QUALITY GRADE

IG

RECOMMENDED BIAS CONDITIONS

- VDS = 10 (V)
- ID = 1.2 (A)
- RG=100 (ohm)

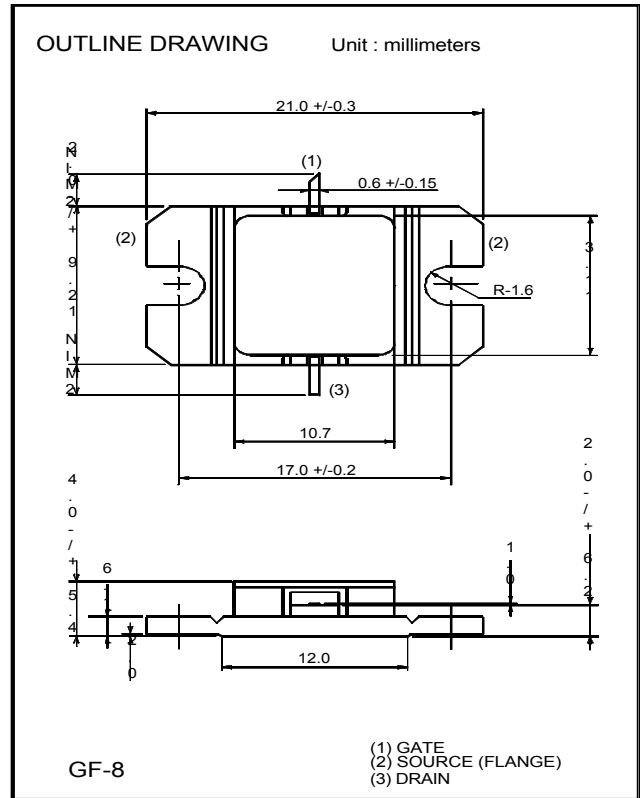

ABSOLUTE MAXIMUM RATINGS

(Ta=25deg.C)

Symbol	Parameter	Ratings	Unit
VGDO	Gate to drain voltage	-15	V
VGSO	Gate to source voltage	-15	V
ID	Drain current	3.75	A
IGR	Reverse gate current	-10	mA
IGF	Forward gate current	21	mA
PT	Total power dissipation *1	25	W
Tch	Channel temperature	175	deg.C
Tstg	Storage temperature	-65 / +175	deg.C

*1 : Tc=25deg.C

< Keep safety first in your circuit design! >

Mitsubishi Electric Corporation puts the maximum effort into making semiconductor products better and more reliable, but there is always the possibility that trouble may occur with them. Trouble with semiconductors may lead to personal injury, fire or property damage. Remember to give due consideration to safety when making your circuit designs, with appropriate measures such as (1)placement of substitutive, auxiliary circuits, (2)use of non-flammable material or (3)prevention against any malfunction or mishap.

ELECTRICAL CHARACTERISTICS

(Ta=25deg.C)

Symbol	Parameter	Test conditions	Limits			Unit
			Min.	Typ.	Max.	
IDSS	Saturated drain current	VDS = 3V , VGS = 0V	-	-	3.75	A
gm	Transconductance	VDS = 3V , ID = 1.1A	-	1	-	S
VGS(off)	Gate to source cut-off voltage	VDS = 3V , ID = 10mA	-	-	-4.5	V
P1dB	Output power at 1dB gain compression	VDS=10V, ID(RF off)=1.2A, f=3.4 - 3.6GHz	35	36	-	dBm
GLP	Linear power gain		11	12	-	dB
ID	Drain current		-	1.1	1.8	A
P.A.E.	Power added efficiency		-	32	-	%
IM3	3rd order IM distortion *1		-42	-45	-	dBc
Rth(ch-c)	Thermal resistance *2		delta Vf method	-	5	6

*1 : item -51,2 tone test,Po=25dBm Single Carrier Level,f=3.6GHz,delta f=5MHz

*2 : Channel-case



MITSUBISHI
ELECTRIC

TYPICAL CHARACTERISTICS (Ta=25deg.C)

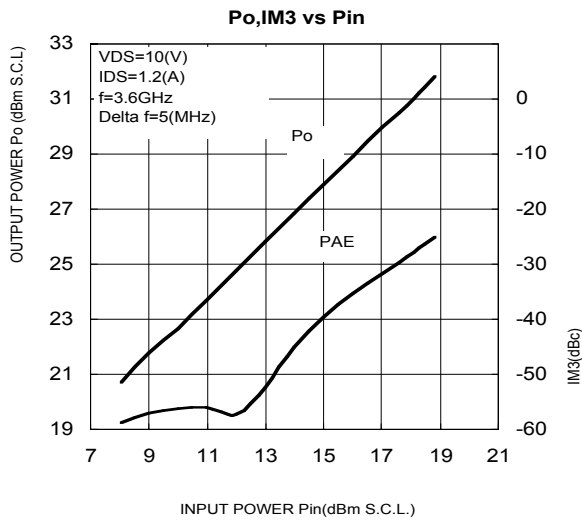
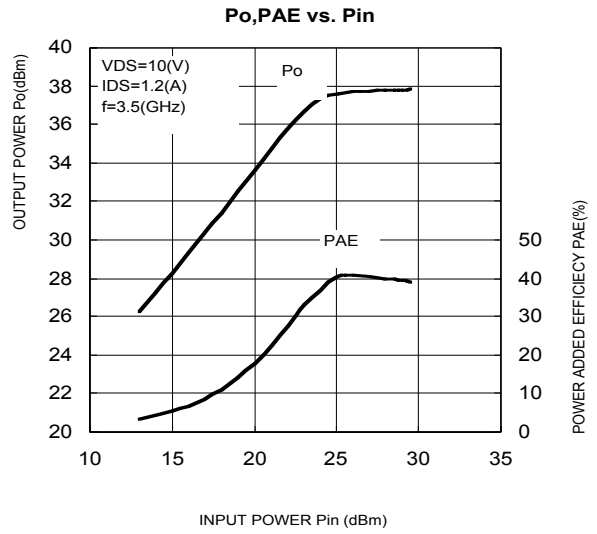
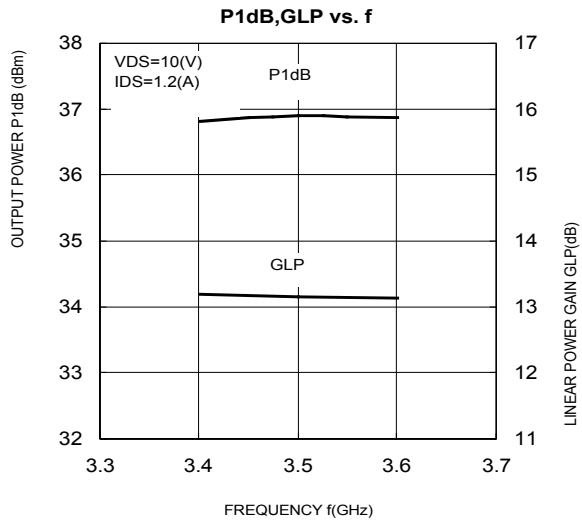

S parameters (Ta=25deg.C , VDS=10(V),IDS=1.2(A))

f (GHz)	S-Parameters (TYP.)							
	S11		S21		S12		S22	
	Magn.	Angle(deg)	Magn.	Angle(deg)	Magn.	Angle(deg)	Magn.	Angle(deg)
3.30	0.48	-179	4.148	29	0.06	-38	0.28	-136
3.35	0.49	166	4.146	16	0.06	-52	0.29	-150
3.40	0.49	159	4.127	9	0.06	-58	0.29	-157
3.45	0.49	145	4.111	-4	0.06	-70	0.30	-170
3.50	0.48	133	4.119	-17	0.06	-79	0.31	178
3.55	0.46	126	4.123	-24	0.07	-85	0.32	171
3.60	0.43	112	4.079	-37	0.07	-97	0.33	158
3.65	0.38	98	4.072	-51	0.07	-113	0.33	145
3.70	0.36	88	4.049	-59	0.07	-118	0.33	140

