

# MGP15N35CL, MGB15N35CL

Preferred Device



ON Semiconductor™

<http://onsemi.com>

## Ignition IGBT 15 Amps, 350 Volts N-Channel TO-220 and D<sup>2</sup>PAK

This Logic Level Insulated Gate Bipolar Transistor (IGBT) features monolithic circuitry integrating ESD and Over-Voltage clamped protection for use in inductive coil drivers applications. Primary uses include Ignition, Direct Fuel Injection, or wherever high voltage and high current switching is required.

- Ideal for Coil-On-Plug, IGBT-On-Coil, or Distributorless Ignition System Applications
- High Pulsed Current Capability up to 50 A
- Gate-Emitter ESD Protection
- Temperature Compensated Gate-Collector Voltage Clamp Limits Stress Applied to Load
- Integrated ESD Diode Protection
- Low Threshold Voltage to Interface Power Loads to Logic or Microprocessor Devices
- Low Saturation Voltage
- Optional Gate Resistor ( $R_G$ )

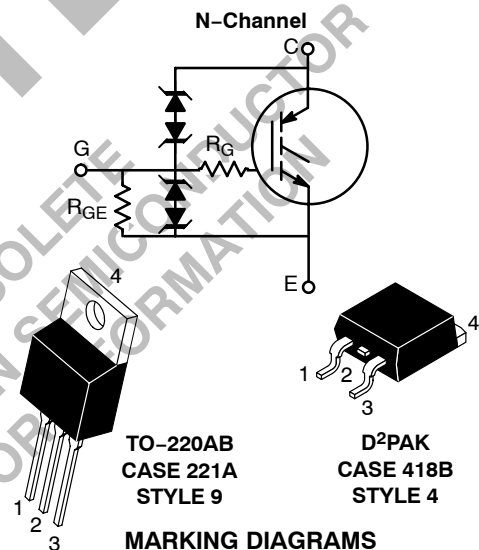
### MAXIMUM RATINGS ( $-55^{\circ}\text{C} \leq T_J \leq 175^{\circ}\text{C}$ unless otherwise noted)

Rating	Symbol	Value	Unit
Collector-Emitter Voltage	$V_{CES}$	380	$V_{DC}$
Collector-Gate Voltage	$V_{CER}$	380	$V_{DC}$
Gate-Emitter Voltage	$V_{GE}$	22	$V_{DC}$
Collector Current-Continuous @ $T_C = 25^{\circ}\text{C}$ - Pulsed	$I_C$	15 50	$A_{DC}$ $A_{AC}$
ESD (Human Body Model) $R = 1500 \Omega$ , $C = 100 \text{ pF}$	ESD	8.0	kV
ESD (Machine Model) $R = 0 \Omega$ , $C = 200 \text{ pF}$	ESD	800	V
Total Power Dissipation @ $T_C = 25^{\circ}\text{C}$ Derate above $25^{\circ}\text{C}$	$P_D$	150 1.0	Watts $\text{W}/^{\circ}\text{C}$
Operating and Storage Temperature Range	$T_J, T_{stg}$	-55 to 175	$^{\circ}\text{C}$

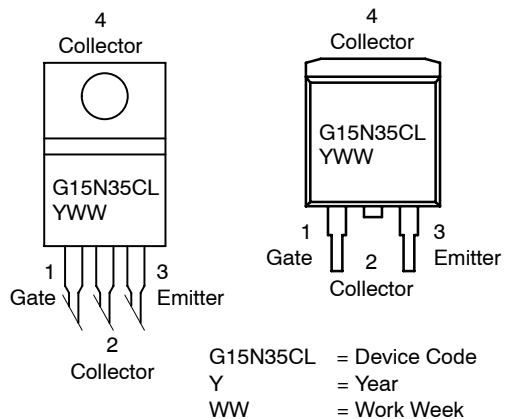
### UNCLAMPED COLLECTOR-TO-EMITTER AVALANCHE CHARACTERISTICS ( $-55^{\circ}\text{C} \leq T_J \leq 175^{\circ}\text{C}$ )

Characteristic	Symbol	Value	Unit
Single Pulse Collector-to-Emitter Avalanche Energy $V_{CC} = 50 \text{ V}$ , $V_{GE} = 5.0 \text{ V}$ , $\text{Pk } I_L = 17.4 \text{ A}$ , $L = 2.0 \text{ mH}$ , Starting $T_J = 25^{\circ}\text{C}$ $V_{CC} = 50 \text{ V}$ , $V_{GE} = 5.0 \text{ V}$ , $\text{Pk } I_L = 14.2 \text{ A}$ , $L = 2.0 \text{ mH}$ , Starting $T_J = 150^{\circ}\text{C}$	$E_{AS}$	300 200	mJ
Reverse Avalanche Energy $V_{CC} = 100 \text{ V}$ , $V_{GE} = 20 \text{ V}$ , $L = 3.0 \text{ mH}$ , $\text{Pk } I_L = 25.8 \text{ A}$ , Starting $T_J = 25^{\circ}\text{C}$	$E_{AS(R)}$	1000	mJ

**15 AMPERES**  
**350 VOLTS (Clamped)**  
 $V_{CE(on)} @ 10 \text{ A} = 1.8 \text{ V Max}$



### MARKING DIAGRAMS & PIN ASSIGNMENTS



### ORDERING INFORMATION

Device	Package	Shipping
MGP15N35CL	TO-220	50 Units/Rail
MGB15N35CLT4	D2PAK	800 Tape & Reel

Preferred devices are recommended choices for future use and best overall value.

# MGP15N35CL, MGB15N35CL

## THERMAL CHARACTERISTICS

Characteristic	Symbol	Value	Unit
Thermal Resistance, Junction to Case	$R_{\theta JC}$	1.0	°C/W
Thermal Resistance, Junction to Ambient	TO-220 $R_{\theta JA}$	62.5	
	D <sup>2</sup> PAK (Note 1) $R_{\theta JA}$	50	
Maximum Lead Temperature for Soldering Purposes, 1/8" from case for 5 seconds	$T_L$	275	°C

## ELECTRICAL CHARACTERISTICS

Characteristic	Symbol	Test Conditions	Temperature	Min	Typ	Max	Unit
----------------	--------	-----------------	-------------	-----	-----	-----	------

### OFF CHARACTERISTICS

Collector-Emitter Clamp Voltage	$BV_{CES}$	$I_C = 2.0 \text{ mA}$	$T_J = -40^\circ\text{C to } 150^\circ\text{C}$	320	350	380	$V_{DC}$
		$I_C = 10 \text{ mA}$	$T_J = -40^\circ\text{C to } 150^\circ\text{C}$	330	360	380	
Zero Gate Voltage Collector Current	$I_{CES}$	$V_{CE} = 300 \text{ V},$ $V_{GE} = 0 \text{ V}$	$T_J = 25^\circ\text{C}$	-	1.5	20	$\mu\text{A}_{DC}$
			$T_J = 150^\circ\text{C}$	-	10	40*	
			$T_J = -40^\circ\text{C}$	-	0.7	1.5	
Reverse Collector-Emitter Leakage Current	$I_{ECS}$	$V_{CE} = -24 \text{ V}$	$T_J = 25^\circ\text{C}$	-	0.35	1.0	mA
			$T_J = 150^\circ\text{C}$	-	8.0	15*	
			$T_J = -40^\circ\text{C}$	-	0.05	0.5	
Reverse Collector-Emitter Clamp Voltage	$BV_{CES(R)}$	$I_C = -75 \text{ mA}$	$T_J = 25^\circ\text{C}$	25	33	50	$V_{DC}$
			$T_J = 150^\circ\text{C}$	25	36	50	
			$T_J = -40^\circ\text{C}$	25	30	50	
Gate-Emitter Clamp Voltage	$BV_{GES}$	$I_G = 5.0 \text{ mA}$	$T_J = -40^\circ\text{C to } 150^\circ\text{C}$	17	20	22	$V_{DC}$
Gate-Emitter Leakage Current	$I_{GES}$	$V_{GE} = 10 \text{ V}$	$T_J = -40^\circ\text{C to } 150^\circ\text{C}$	384	600	1000	$\mu\text{A}_{DC}$
Gate Resistor (Optional)	$R_G$	-	$T_J = -40^\circ\text{C to } 150^\circ\text{C}$	-	70	-	$\Omega$
Gate Emitter Resistor	$R_{GE}$	-	$T_J = -40^\circ\text{C to } 150^\circ\text{C}$	10	16	26	k $\Omega$

### ON CHARACTERISTICS (Note 2)

Gate Threshold Voltage	$V_{GE(th)}$	$I_C = 1.0 \text{ mA},$ $V_{GE} = V_{CE}$	$T_J = 25^\circ\text{C}$	1.4	1.7	2.0	$V_{DC}$
			$T_J = 150^\circ\text{C}$	0.75	1.1	1.4	
			$T_J = -40^\circ\text{C}$	1.6	1.9	2.1*	
Threshold Temperature Coefficient (Negative)	-	-	-	-	4.4	-	mV/°C

1. When surface mounted to an FR4 board using the minimum recommended pad size.

2. Pulse Test: Pulse Width  $\leq 300 \mu\text{s}$ , Duty Cycle  $\leq 2\%$ .

\*Maximum Value of Characteristic across Temperature Range.

# MGP15N35CL, MGB15N35CL

## ELECTRICAL CHARACTERISTICS (continued)

Characteristic	Symbol	Test Conditions	Temperature	Min	Typ	Max	Unit
----------------	--------	-----------------	-------------	-----	-----	-----	------

### ON CHARACTERISTICS (continued) (Note 3)

Collector-to-Emitter On-Voltage	$V_{CE(on)}$	$I_C = 6.0 \text{ A}$ , $V_{GE} = 4.0 \text{ V}$	$T_J = 25^\circ\text{C}$	1.0	1.3	1.6	$V_{DC}$
			$T_J = 150^\circ\text{C}$	0.9	1.2	1.5	
			$T_J = -40^\circ\text{C}$	1.1	1.4	1.7*	
		$I_C = 10 \text{ A}$ , $V_{GE} = 4.0 \text{ V}$	$T_J = 25^\circ\text{C}$	1.3	1.6	1.9	
			$T_J = 150^\circ\text{C}$	1.2	1.5	1.8	
			$T_J = -40^\circ\text{C}$	1.3	1.6	1.9*	
		$I_C = 15 \text{ A}$ , $V_{GE} = 4.0 \text{ V}$	$T_J = 25^\circ\text{C}$	1.6	1.95	2.25	
			$T_J = 150^\circ\text{C}$	1.7	2.0	2.3*	
			$T_J = -40^\circ\text{C}$	1.6	1.9	2.2	
		$I_C = 20 \text{ A}$ , $V_{GE} = 4.0 \text{ V}$	$T_J = 25^\circ\text{C}$	1.9	2.2	2.5	
			$T_J = 150^\circ\text{C}$	2.1	2.4	2.7*	
			$T_J = -40^\circ\text{C}$	1.85	2.15	2.45	
$I_C = 25 \text{ A}$ , $V_{GE} = 4.0 \text{ V}$	$T_J = 25^\circ\text{C}$	2.1	2.5	2.9			
	$T_J = 150^\circ\text{C}$	2.5	2.9	3.3*			
	$T_J = -40^\circ\text{C}$	2.0	2.4	2.8			
Collector-to-Emitter On-Voltage	$V_{CE(on)}$	$I_C = 10 \text{ A}$ , $V_{GE} = 4.5 \text{ V}$	$T_J = 150^\circ\text{C}$	-	1.5	1.8	$V_{DC}$
Forward Transconductance	gfs	$V_{CE} = 5.0 \text{ V}$ , $I_C = 6.0 \text{ A}$	$T_J = -40^\circ\text{C}$ to $150^\circ\text{C}$	8.0	15	25	Mhos

### DYNAMIC CHARACTERISTICS

Input Capacitance	$C_{ISS}$	$V_{CC} = 25 \text{ V}$ , $V_{GE} = 0 \text{ V}$ $f = 1.0 \text{ MHz}$	$T_J = -40^\circ\text{C}$ to $150^\circ\text{C}$	-	1000	1300	pF
Output Capacitance	$C_{OSS}$			-	100	130	
Transfer Capacitance	$C_{RSS}$			-	5.0	8.0	

### SWITCHING CHARACTERISTICS (Note 3)

Turn-Off Delay Time (Inductive)	$t_{d(off)}$	$V_{CC} = 300 \text{ V}$ , $I_C = 6.5 \text{ A}$ $R_G = 1.0 \text{ k}\Omega$ , $L = 300 \mu\text{H}$	$T_J = 25^\circ\text{C}$	-	4.0	10	$\mu\text{Sec}$
			$T_J = 150^\circ\text{C}$	-	4.5	10	
Fall Time (Inductive)	$t_f$	$V_{CC} = 300 \text{ V}$ , $I_C = 6.5 \text{ A}$ $R_G = 1.0 \text{ k}\Omega$ , $L = 300 \mu\text{H}$	$T_J = 25^\circ\text{C}$	-	7.0	10	$\mu\text{Sec}$
			$T_J = 150^\circ\text{C}$	-	10	15*	
Turn-Off Delay Time (Resistive)	$t_{d(off)}$	$V_{CC} = 300 \text{ V}$ , $I_C = 6.5 \text{ A}$ $R_G = 1.0 \text{ k}\Omega$ , $R_L = 46 \Omega$	$T_J = 25^\circ\text{C}$	-	4.0	10	$\mu\text{Sec}$
			$T_J = 150^\circ\text{C}$	-	4.5	10	
Fall Time (Resistive)	$t_f$	$V_{CC} = 300 \text{ V}$ , $I_C = 6.5 \text{ A}$ $R_G = 1.0 \text{ k}\Omega$ , $R_L = 46 \Omega$	$T_J = 25^\circ\text{C}$	-	13	20	$\mu\text{Sec}$
			$T_J = 150^\circ\text{C}$	-	16	20	
Turn-On Delay Time	$t_{d(on)}$	$V_{CC} = 10 \text{ V}$ , $I_C = 6.5 \text{ A}$ $R_G = 1.0 \text{ k}\Omega$ , $R_L = 1.5 \Omega$	$T_J = 25^\circ\text{C}$	-	1.0	1.5	$\mu\text{Sec}$
			$T_J = 150^\circ\text{C}$	-	1.0	1.5	
Rise Time	$t_r$	$V_{CC} = 10 \text{ V}$ , $I_C = 6.5 \text{ A}$ $R_G = 1.0 \text{ k}\Omega$ , $R_L = 1.5 \Omega$	$T_J = 25^\circ\text{C}$	-	4.5	6.0	$\mu\text{Sec}$
			$T_J = 150^\circ\text{C}$	-	5.0	6.0	

3. Pulse Test: Pulse Width  $\leq 300 \mu\text{s}$ , Duty Cycle  $\leq 2\%$ .

\*Maximum Value of Characteristic across Temperature Range.

# MGP15N35CL, MGB15N35CL

## TYPICAL ELECTRICAL CHARACTERISTICS (unless otherwise noted)

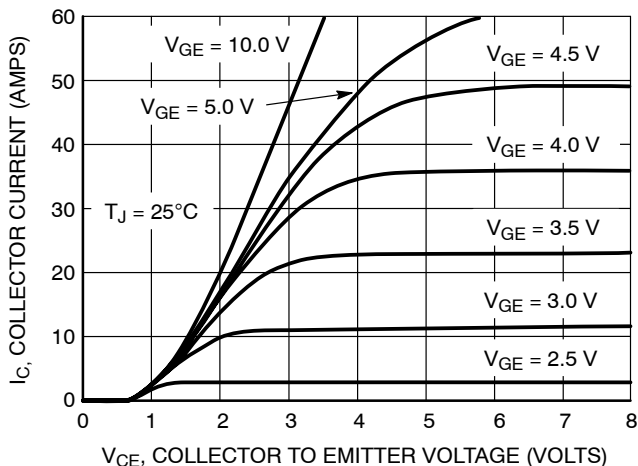


Figure 1. Output Characteristics

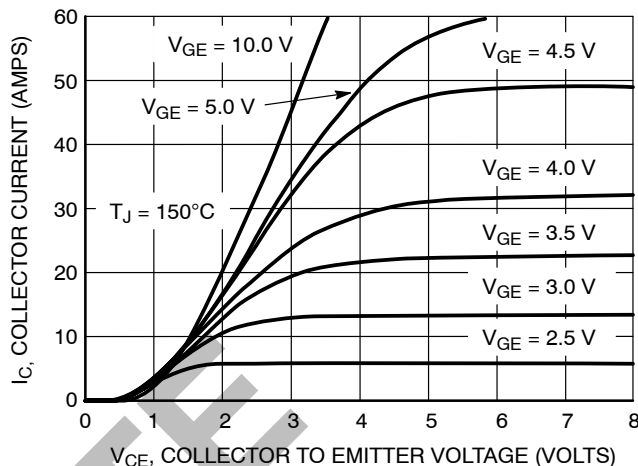


Figure 2. Output Characteristics

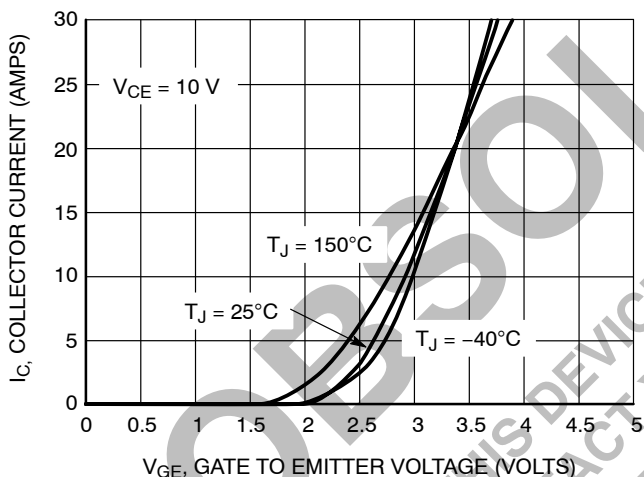


Figure 3. Transfer Characteristics

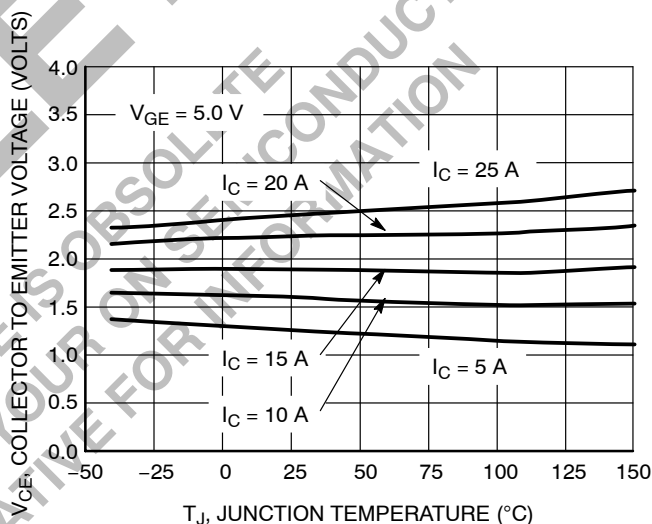


Figure 4. Collector-to-Emitter Saturation Voltage vs. Junction Temperature

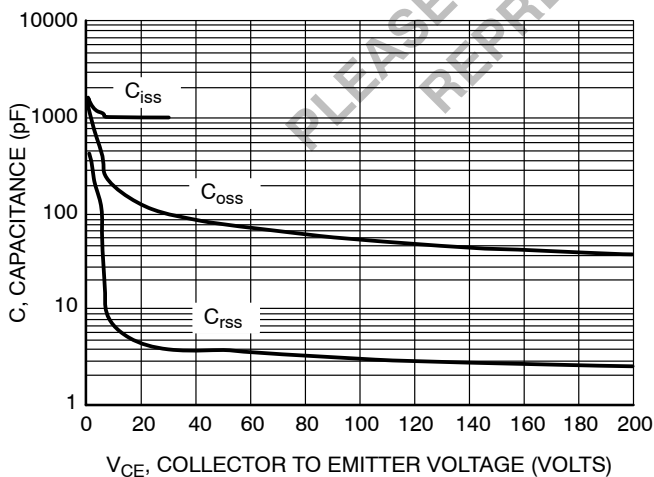


Figure 5. Capacitance Variation

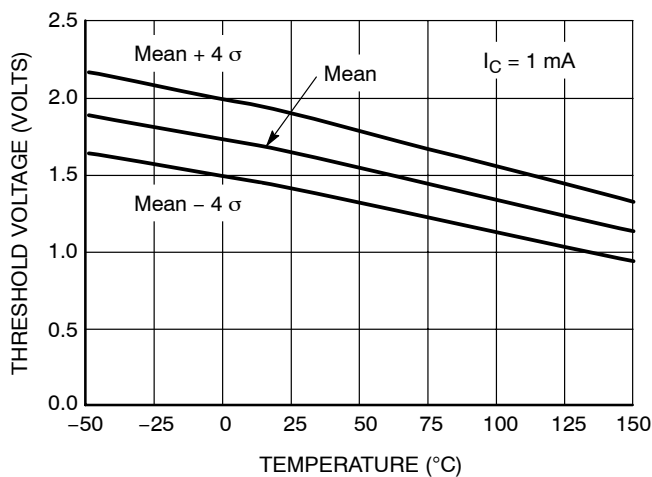
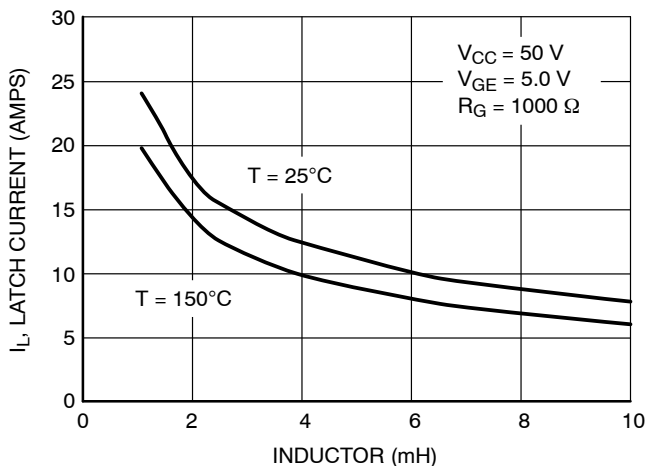
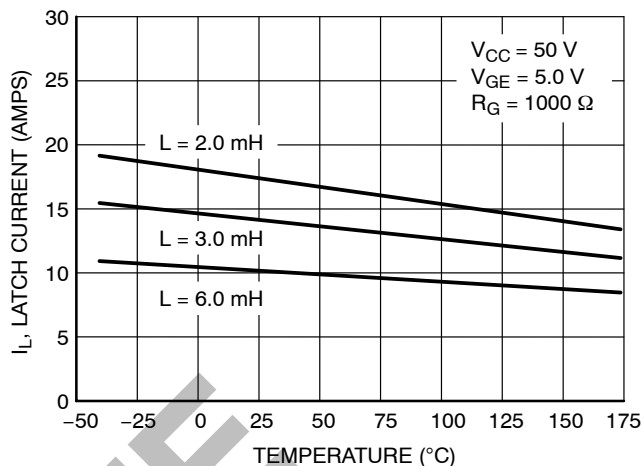


Figure 6. Threshold Voltage vs. Temperature

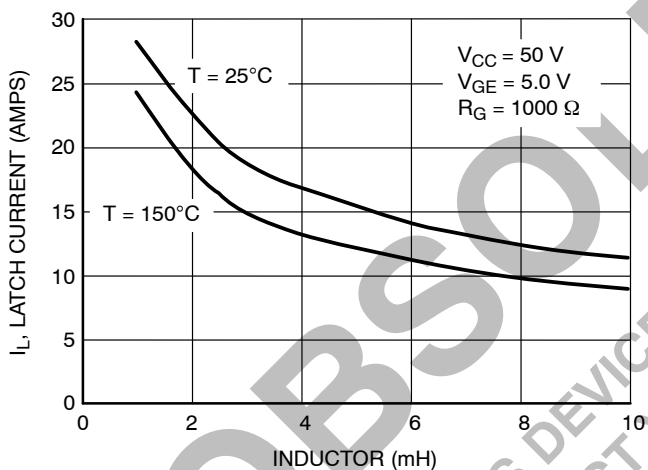
# MGP15N35CL, MGB15N35CL



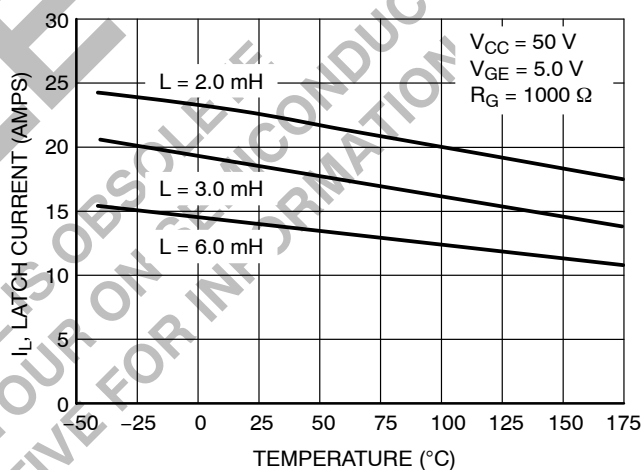
**Figure 7. Minimum Open Secondary Latch Current vs. Inductor**



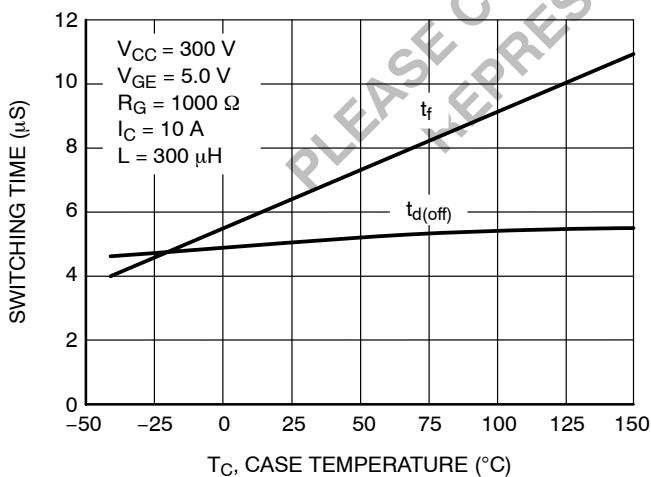
**Figure 8. Minimum Open Secondary Latch Current vs. Temperature**



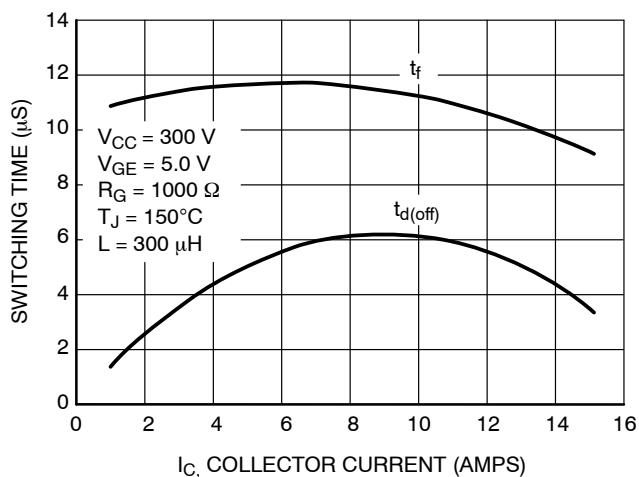
**Figure 9. Typical Open Secondary Latch Current vs. Inductor**



**Figure 10. Typical Open Secondary Latch Current vs. Temperature**

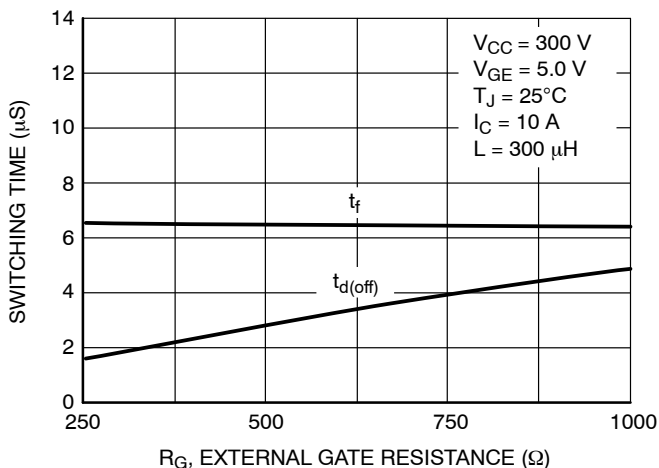


**Figure 11. Switching Speed vs. Case Temperature**

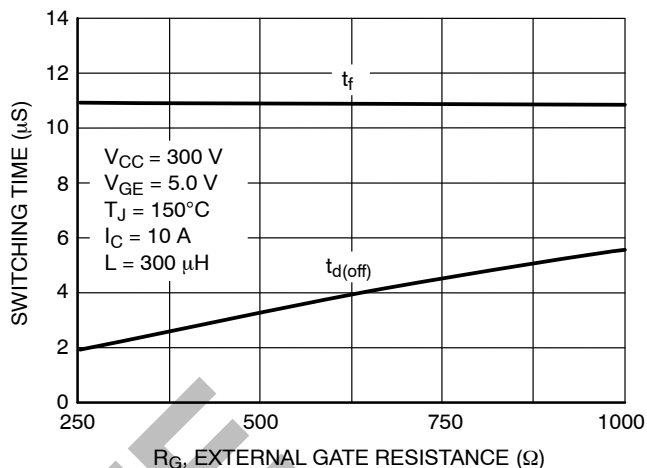


**Figure 12. Switching Speed vs. Collector Current**

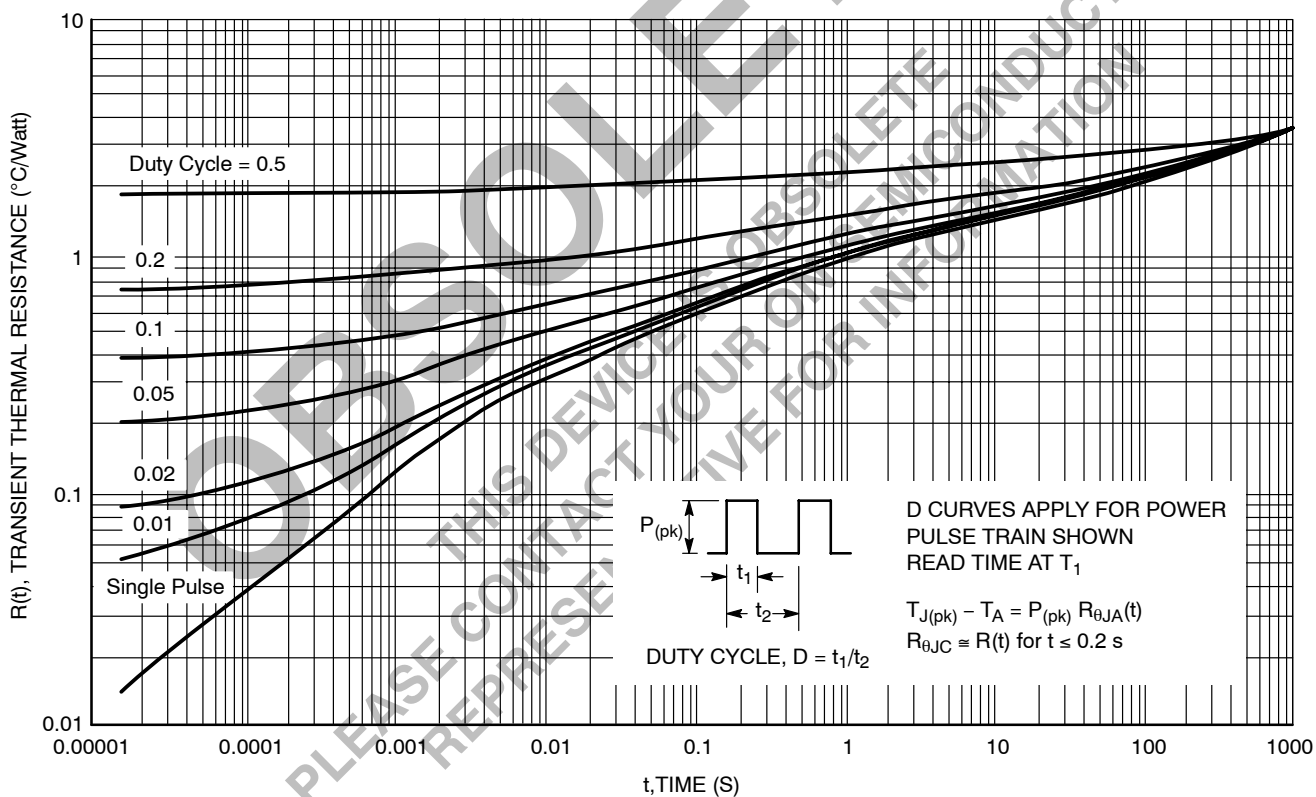
# MGP15N35CL, MGB15N35CL



**Figure 13. Switching Speed vs. External Gate Resistance**

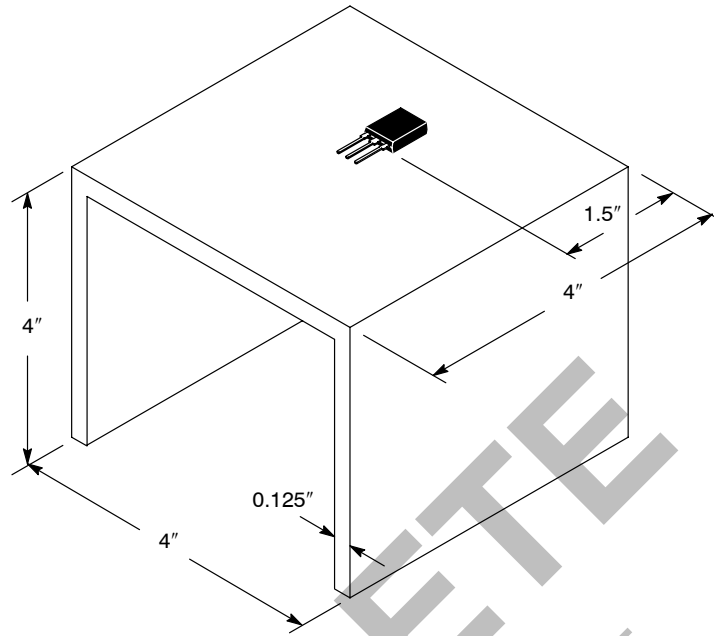


**Figure 14. Switching Speed vs. External Gate Resistance**

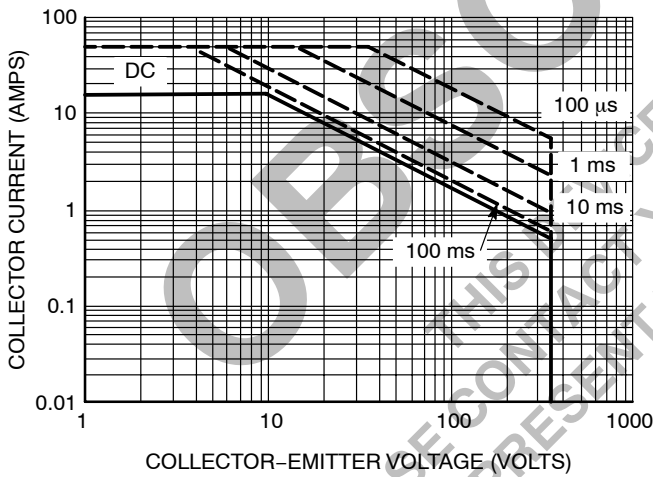


**Figure 15. Transient Thermal Resistance (Non-normalized Junction-to-Ambient mounted on fixture in Figure 16)**

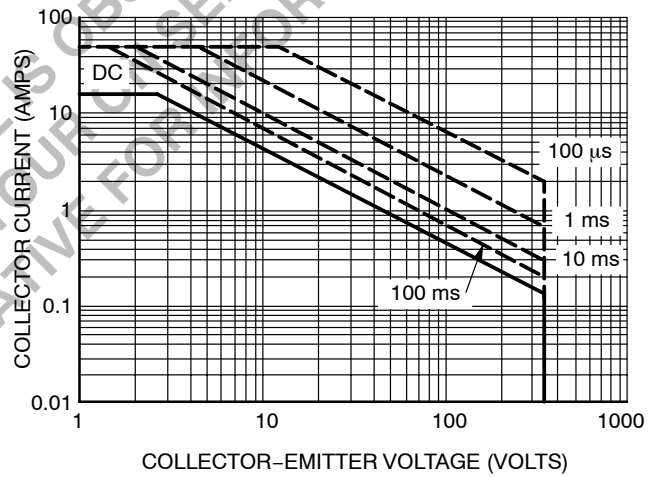
# MGP15N35CL, MGB15N35CL



**Figure 16. Test Fixture for Transient Thermal Curve  
(48 square inches of 1/8" thick aluminum)**



**Figure 17. Single Pulse Safe Operating Area  
(Mounted on an Infinite Heatsink at  $T_C = 25^\circ\text{C}$ )**



**Figure 18. Single Pulse Safe Operating Area  
(Mounted on an Infinite Heatsink at  $T_C = 125^\circ\text{C}$ )**

MGP15N35CL, MGB15N35CL

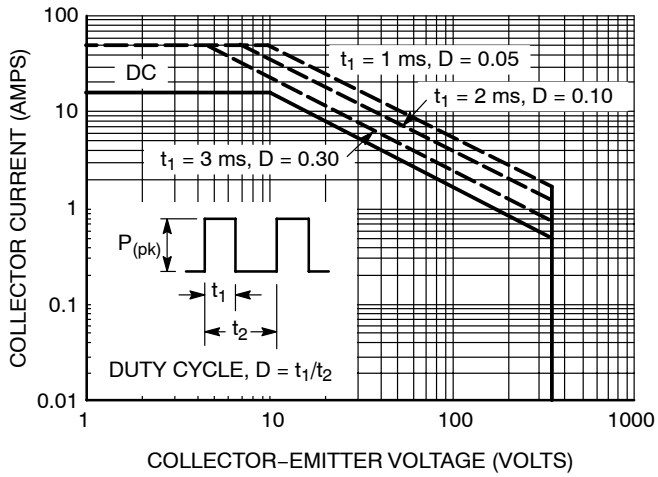


Figure 19. Pulse Train Safe Operating Area  
(Mounted on an Infinite Heatsink at  $T_C = 25^\circ\text{C}$ )

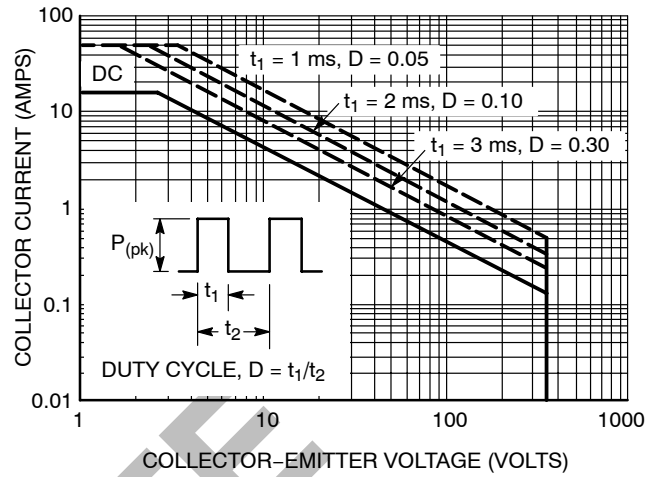


Figure 20. Pulse Train Safe Operating Area  
(Mounted on an Infinite Heatsink at  $T_C = 125^\circ\text{C}$ )

OBSOLETE

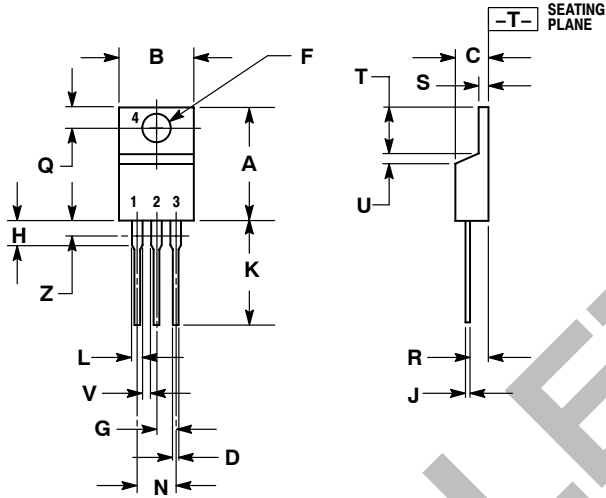
THIS DEVICE IS OBSOLETE  
PLEASE CONTACT YOUR ON SEMICONDUCTOR  
REPRESENTATIVE FOR INFORMATION



# MGP15N35CL, MGB15N35CL

## PACKAGE DIMENSIONS

TO-220 THREE-LEAD  
 TO-220AB  
 CASE 221A-09  
 ISSUE AA



NOTES:

1. DIMENSIONING AND TOLERANCING PER ANSI Y14.5M, 1982.
2. CONTROLLING DIMENSION: INCH.
3. DIMENSION Z DEFINES A ZONE WHERE ALL BODY AND LEAD IRREGULARITIES ARE ALLOWED.

DIM	INCHES		MILLIMETERS	
	MIN	MAX	MIN	MAX
A	0.570	0.620	14.48	15.75
B	0.380	0.405	9.66	10.28
C	0.160	0.190	4.07	4.82
D	0.025	0.035	0.64	0.88
F	0.142	0.147	3.61	3.73
G	0.095	0.105	2.42	2.66
H	0.110	0.155	2.80	3.93
J	0.018	0.025	0.46	0.64
K	0.500	0.562	12.70	14.27
L	0.045	0.060	1.15	1.52
N	0.190	0.210	4.89	5.33
Q	0.100	0.120	2.54	3.04
R	0.080	0.110	2.04	2.79
S	0.045	0.055	1.15	1.39
T	0.235	0.255	5.97	6.47
U	0.000	0.050	0.00	1.27
V	0.045	---	1.15	---
Z	---	0.080	---	2.04

STYLE 9:

- PIN 1. GATE
- COLLECTOR
- EMITTER
- COLLECTOR

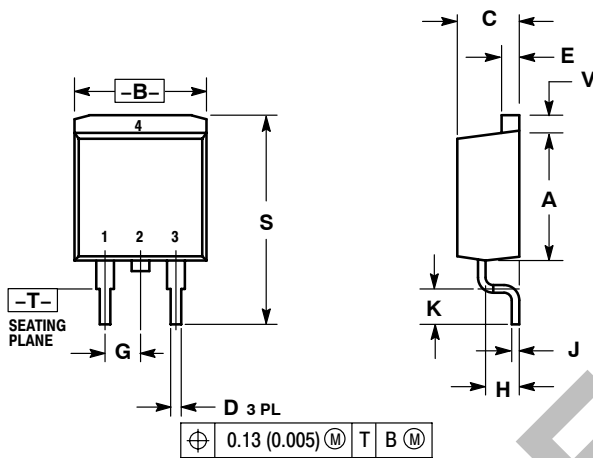
OBSOLETE

THIS DEVICE IS OBSOLETE  
 PLEASE CONTACT YOUR ON SEMICONDUCTOR  
 REPRESENTATIVE FOR INFORMATION

# MGP15N35CL, MGB15N35CL

## PACKAGE DIMENSIONS

D<sup>2</sup>PAK  
CASE 418B-03  
ISSUE D



- NOTES:  
1. DIMENSIONING AND TOLERANCING PER ANSI Y14.5M, 1982.  
2. CONTROLLING DIMENSION: INCH.

DIM	INCHES		MILLIMETERS	
	MIN	MAX	MIN	MAX
A	0.340	0.380	8.64	9.65
B	0.380	0.405	9.65	10.29
C	0.160	0.190	4.06	4.83
D	0.020	0.035	0.51	0.89
E	0.045	0.055	1.14	1.40
G	0.100 BSC		2.54 BSC	
H	0.080	0.110	2.03	2.79
J	0.018	0.025	0.46	0.64
K	0.090	0.110	2.29	2.79
S	0.575	0.625	14.60	15.88
V	0.045	0.055	1.14	1.40

- STYLE 4:  
PIN 1. GATE  
2. COLLECTOR  
3. EMITTER  
4. COLLECTOR

ON Semiconductor and are registered trademarks of Semiconductor Components Industries, LLC (SCILLC). SCILLC reserves the right to make changes without further notice to any products herein. SCILLC makes no warranty, representation or guarantee regarding the suitability of its products for any particular purpose, nor does SCILLC assume any liability arising out of the application or use of any product or circuit, and specifically disclaims any and all liability, including without limitation special, consequential or incidental damages. "Typical" parameters which may be provided in SCILLC data sheets and/or specifications can and do vary in different applications and actual performance may vary over time. All operating parameters, including "Typicals" must be validated for each customer application by customer's technical experts. SCILLC does not convey any license under its patent rights nor the rights of others. SCILLC products are not designed, intended, or authorized for use as components in systems intended for surgical implant into the body, or other applications intended to support or sustain life, or for any other application in which the failure of the SCILLC product could create a situation where personal injury or death may occur. Should Buyer purchase or use SCILLC products for any such unintended or unauthorized application, Buyer shall indemnify and hold SCILLC and its officers, employees, subsidiaries, affiliates, and distributors harmless against all claims, costs, damages, and expenses, and reasonable attorney fees arising out of, directly or indirectly, any claim of personal injury or death associated with such unintended or unauthorized use, even if such claim alleges that SCILLC was negligent regarding the design or manufacture of the part. SCILLC is an Equal Opportunity/Affirmative Action Employer. This literature is subject to all applicable copyright laws and is not for resale in any manner.

### PUBLICATION ORDERING INFORMATION

**LITERATURE FULFILLMENT:**  
Literature Distribution Center for ON Semiconductor  
P.O. Box 5163, Denver, Colorado 80217 USA  
**Phone:** 303-675-2175 or 800-344-3860 Toll Free USA/Canada  
**Fax:** 303-675-2176 or 800-344-3867 Toll Free USA/Canada  
**Email:** orderlit@onsemi.com

**N. American Technical Support:** 800-282-9855 Toll Free  
USA/Canada  
**Europe, Middle East and Africa Technical Support:**  
Phone: 421 33 790 2910  
**Japan Customer Focus Center**  
Phone: 81-3-5773-3850

**ON Semiconductor Website:** [www.onsemi.com](http://www.onsemi.com)  
**Order Literature:** <http://www.onsemi.com/orderlit>

For additional information, please contact your local Sales Representative