

## 1A, 1.2 MHz PWM Boost Converter

### Features

- 2.5V to 10V Input Voltage Range
- Output Voltage Adjustable to 34V
- Over 1A Switch Current
- 1.2 MHz PWM Operation
- Stable with Ceramic Capacitors
- <1% Line and Load Regulation
- Low Output Voltage Ripple
- <1  $\mu$ A Shutdown Current
- Undervoltage Lockout
- Output Overvoltage Protection (MIC2288YML)
- Overtemperature Shutdown
- Thin SOT23-5 Package Option
- 2 mm x 2 mm leadless VDFN-8 Package Option
- $-40^{\circ}\text{C}$  to  $+125^{\circ}\text{C}$  Junction Temperature Range

### Applications

- Organic EL Power Supply
- TFT-LCD Bias Supply
- 12V Supply for DSL Applications
- Multi-Output DC/DC Converters
- Positive and Negative Output Regulators
- SEPIC Converters

### General Description

The MIC2288 is a 1.2 MHz PWM, DC/DC boost switching regulator available in low-profile Thin SOT23 and 2 mm x 2 mm VDFN package options. High power density is achieved with the MIC2288's internal 34V/1A switch, allowing it to power large loads in a tiny footprint.

The MIC2288 implements a constant frequency, 1.2 MHz PWM, current mode control scheme with internal compensation that offers excellent transient response and output regulation performance. The high frequency operation saves board space by allowing small, low-profile, external components. The fixed frequency PWM topology also reduces spurious switching noise and ripple to the input power source.

The MIC2288 is available in a low-profile Thin SOT23-5 package and a 2 mm x 2 mm VDFN-8 leadless package. The DFN package option has an output overvoltage protection feature.

The MIC2288 has a junction temperature range of  $-40^{\circ}\text{C}$  to  $+125^{\circ}\text{C}$ .

### Package Types

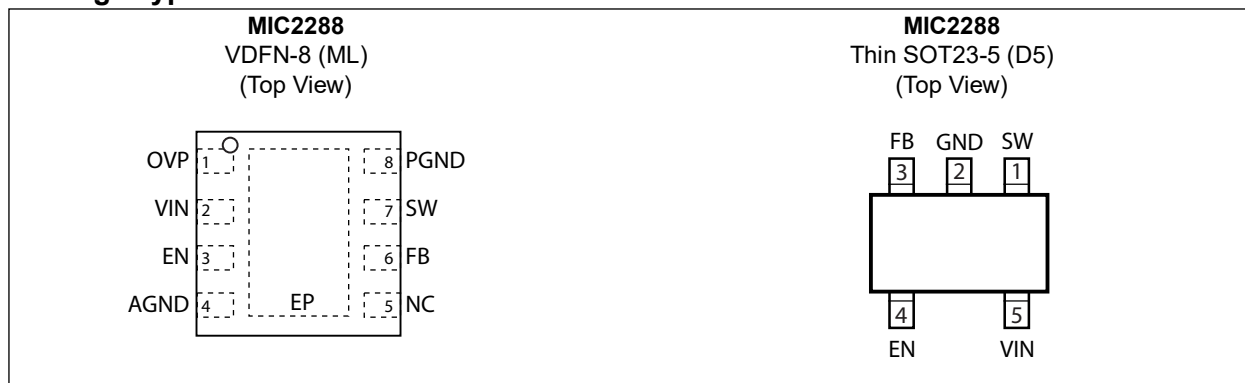

# MIC2288

## Typical Application Circuit

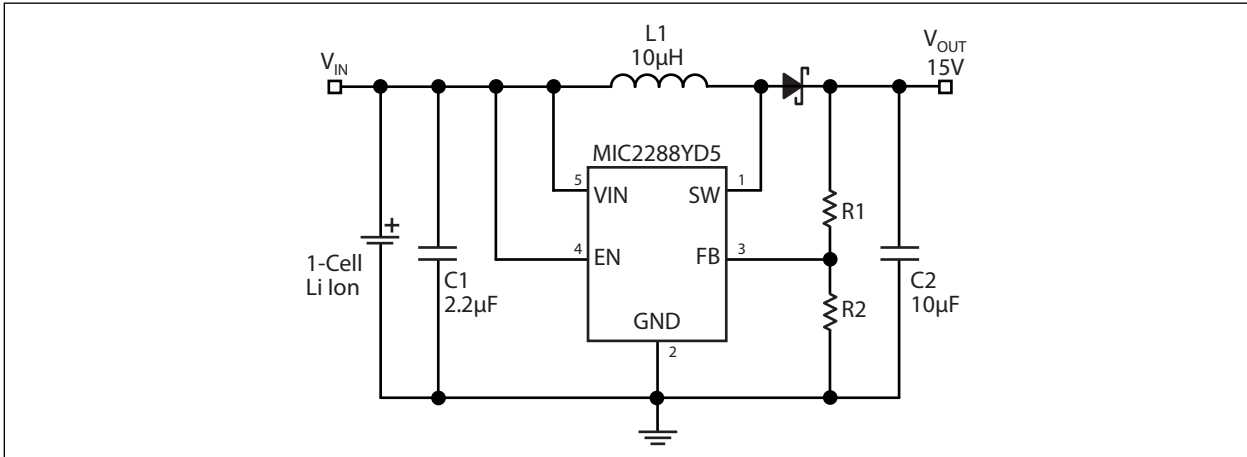

## Functional Block Diagram

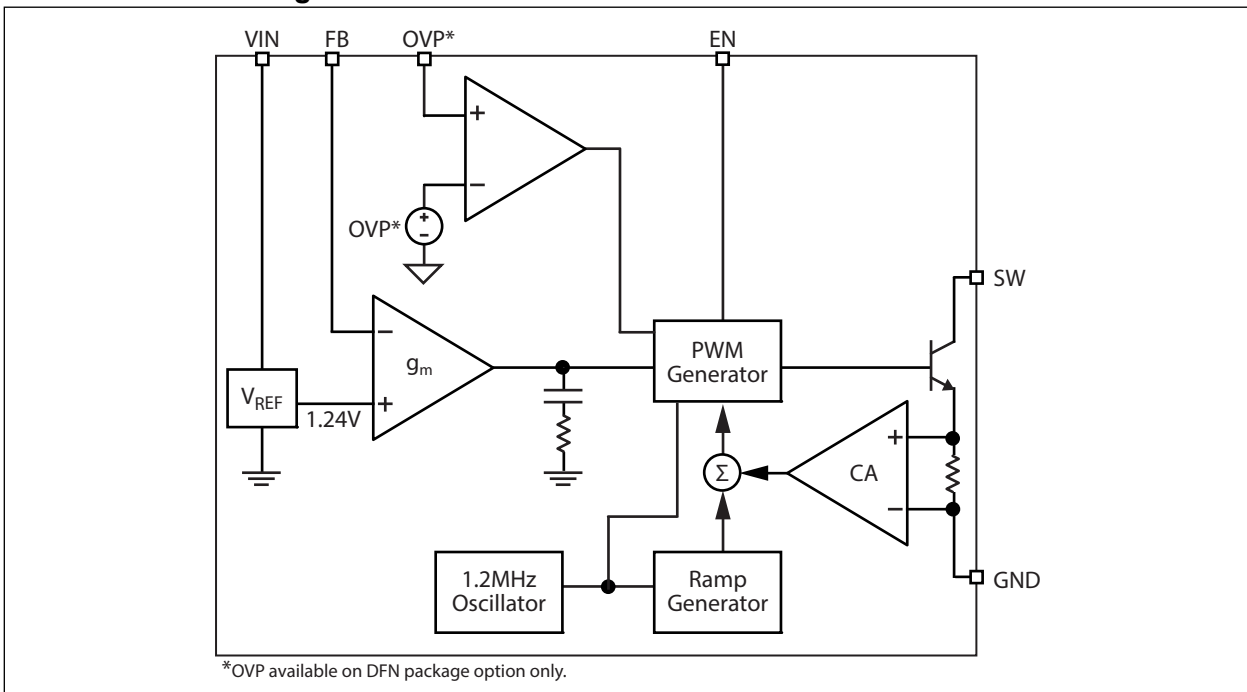

## 1.0 ELECTRICAL CHARACTERISTICS

### Absolute Maximum Ratings †

Supply Voltage ( $V_{IN}$ ) .....	+12V
Switch Voltage ( $V_{SW}$ ) .....	-0.3V to +34V
Enable Pin Voltage ( $V_{EN}$ ) .....	-0.3V to $V_{IN}$
FB Voltage ( $V_{FB}$ ) .....	+6.0V
Switch Current ( $I_{SW}$ ) .....	2A
ESD Rating (Note 1) .....	+2 kV

### Operating Ratings ††

Supply Voltage ( $V_{IN}$ ) .....	+2.5V to +10V
-----------------------------------	---------------

**† Notice:** Stresses above those listed under “Absolute Maximum Ratings” may cause permanent damage to the device. This is a stress rating only and functional operation of the device at those or any other conditions above those indicated in the operational sections of this specification is not intended. Exposure to maximum rating conditions for extended periods may affect device reliability.

**†† Notice:** The device is not guaranteed to function outside its operating ratings.

**Note 1:** Devices are ESD sensitive. Handling precautions are recommended. Human body model, 1.5 k $\Omega$  in series with 100 pF.

# MIC2288

## ELECTRICAL CHARACTERISTICS

**Electrical Characteristics:**  $T_A = +25^\circ\text{C}$ ,  $V_{IN} = V_{EN} = 3.6\text{V}$ ,  $V_{OUT} = 10\text{V}$ ,  $I_{OUT} = 20\text{ mA}$ , unless otherwise noted. **Bold** values valid for  $-40^\circ\text{C} \leq T_J \leq \pm 125^\circ\text{C}$ . [Note 1](#)

Parameter	Sym.	Min.	Typ.	Max.	Units	Conditions
Supply Voltage Range	$V_{IN}$	<b>2.5</b>	—	<b>10</b>	V	—
Undervoltage Lockout	$V_{UVLO}$	1.8	2.1	2.4	V	—
Quiescent Current	$I_{VIN}$	—	2.8	5	mA	$V_{FB} = 2\text{V}$ , not switching
Shutdown Current	$I_{SD}$	—	0.1	1	$\mu\text{A}$	$V_{EN} = 0\text{V}$ , <a href="#">Note 2</a>
Feedback Voltage	$V_{FB}$	1.227	1.24	1.252	V	$\pm 1\%$
		<b>1.215</b>	—	<b>1.265</b>		$\pm 2\%$ , over temperature
Feedback Input Current	$I_{FB}$	—	-450	—	nA	$V_{FB} = 1.24\text{V}$
Line Regulation	—	—	0.1	1	%	$3\text{V} \leq V_{IN} \leq 5\text{V}$
Load Regulation	—	—	0.2	—	%	$5\text{ mA} \leq I_{OUT} \leq 40\text{ mA}$
Maximum Duty Cycle	$D_{MAX}$	<b>85</b>	90	—	%	—
Switch Current Limit	$I_{SW}$	—	1.2	—	A	—
Switch Saturation Voltage	$V_{SW}$	—	550	—	mV	$I_{SW} = 1\text{A}$
Switch Leakage Current	$I_{SW}$	—	0.01	<b>5</b>	$\mu\text{A}$	$V_{EN} = 0\text{V}$ , $V_{SW} = 10\text{V}$
Enable Threshold	$V_{EN}$	<b>1.5</b>	—	—	V	Turn on
		—	—	<b>0.4</b>		Turn off
Enable Pin Current	$I_{EN}$	—	20	40	$\mu\text{A}$	$V_{EN} = 10\text{V}$
Oscillator Frequency	$f_{SW}$	1.05	1.2	1.35	MHz	—
Output Overvoltage Protection	$V_{OVP}$	30	32	34	V	VDFN package option only
Overtemperature Threshold Shutdown	$T_J$	—	150	—	$^\circ\text{C}$	—
		—	10	—		Hysteresis

**Note 1:** Specification for packaged product only.

**2:**  $I_{SD} = I_{VIN}$ .

## TEMPERATURE SPECIFICATIONS

Parameters	Sym.	Min.	Typ.	Max.	Units	Conditions
<b>Temperature Ranges</b>						
Junction Operating Temperature	$T_J$	-40	—	+125	°C	—
Storage Temperature Range	$T_S$	-65	—	+150	°C	—
<b>Package Thermal Resistances</b>						
Thermal Resistance, 2x2 VDFN 8-Ld	$\theta_{JA}$	—	93	—	°C/W	—
Thermal Resistance, TSOT23-5	$\theta_{JA}$	—	256	—	°C/W	—

**Note 1:** The maximum allowable power dissipation is a function of ambient temperature, the maximum allowable junction temperature and the thermal resistance from junction to air (i.e.,  $T_A$ ,  $T_J$ ,  $\theta_{JA}$ ). Exceeding the maximum allowable power dissipation will cause the device operating junction temperature to exceed the maximum +125°C rating. Sustained junction temperatures above +125°C can impact the device reliability.

# MIC2288

## 2.0 TYPICAL PERFORMANCE CURVES

**Note:** The graphs and tables provided following this note are a statistical summary based on a limited number of samples and are provided for informational purposes only. The performance characteristics listed herein are not tested or guaranteed. In some graphs or tables, the data presented may be outside the specified operating range (e.g., outside specified power supply range) and therefore outside the warranted range.

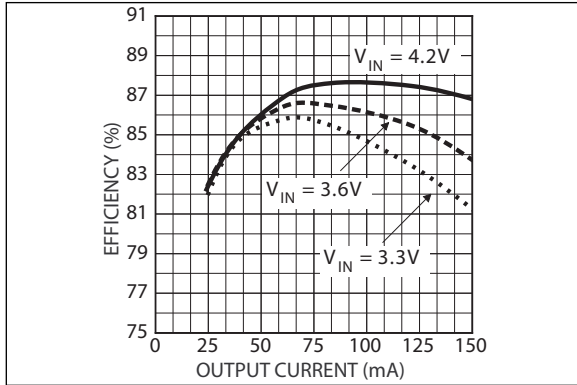

**FIGURE 2-1:** Efficiency at  $V_{OUT} = 12V$ .

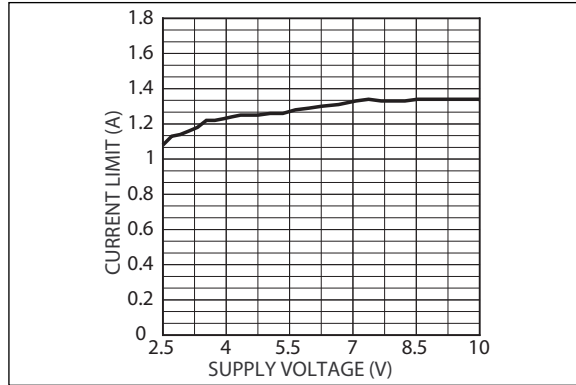

**FIGURE 2-4:** Current-Limit vs. Supply Voltage.

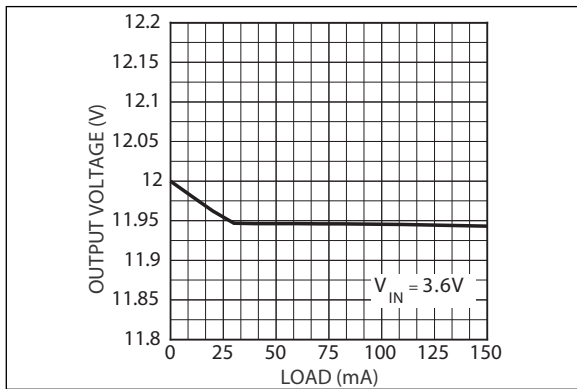

**FIGURE 2-2:** Load Regulation.

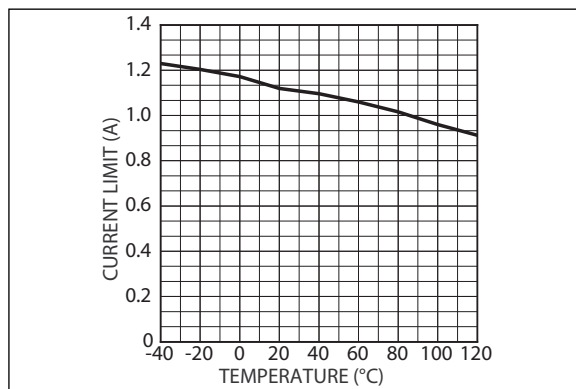

**FIGURE 2-5:** Current-Limit vs. Temperature.

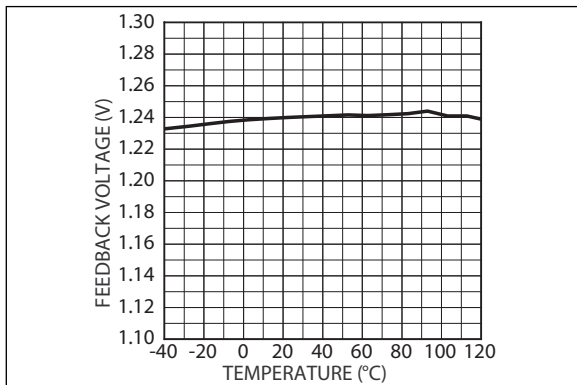

**FIGURE 2-3:** Feedback Voltage vs. Temperature.

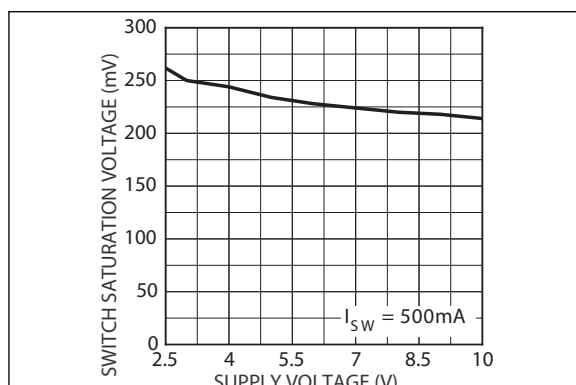

**FIGURE 2-6:** Switch Saturation vs. Supply Voltage.

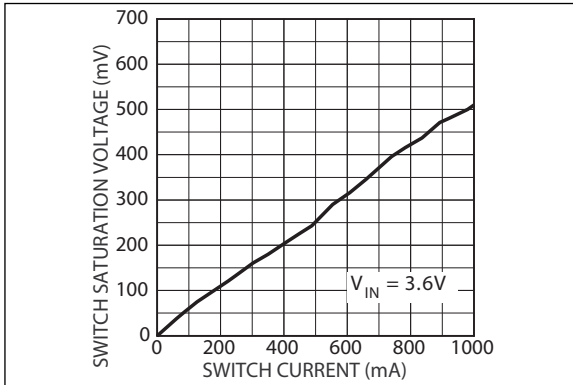

**FIGURE 2-7:** Switch Saturation vs. Switch Current.

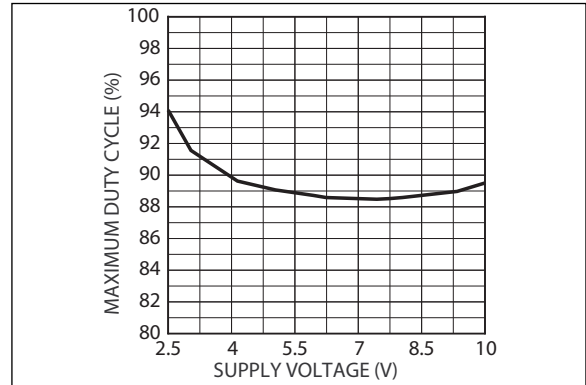

**FIGURE 2-10:** Maximum Duty Cycle vs. Supply Voltage.

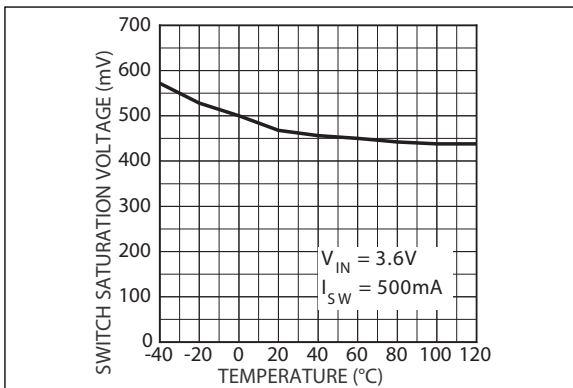

**FIGURE 2-8:** Switch Saturation vs. Temperature.

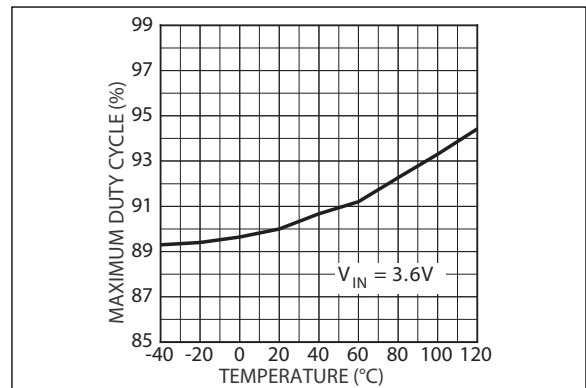

**FIGURE 2-11:** Maximum Duty Cycle vs. Temperature.

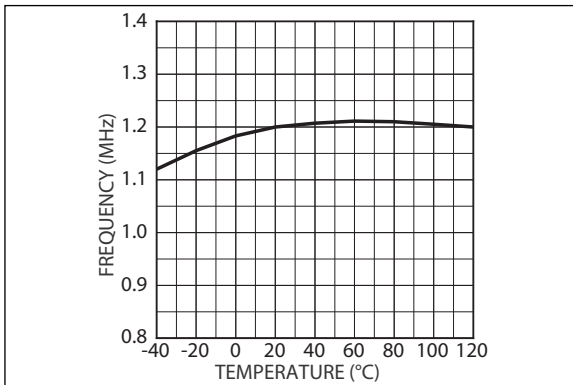

**FIGURE 2-9:** Frequency vs. Temperature.

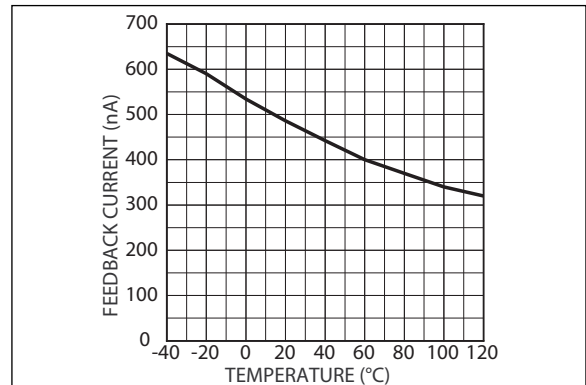

**FIGURE 2-12:** FB Pin Current vs. Temperature.

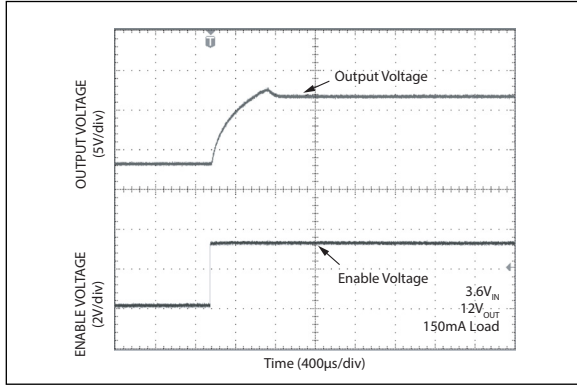

**FIGURE 2-13:** Enable Characteristics.

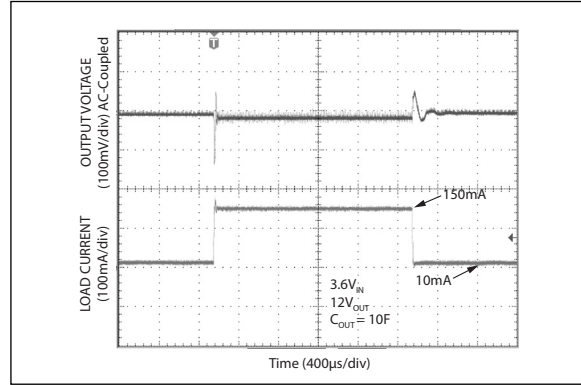

**FIGURE 2-15:** Load Transient Response.

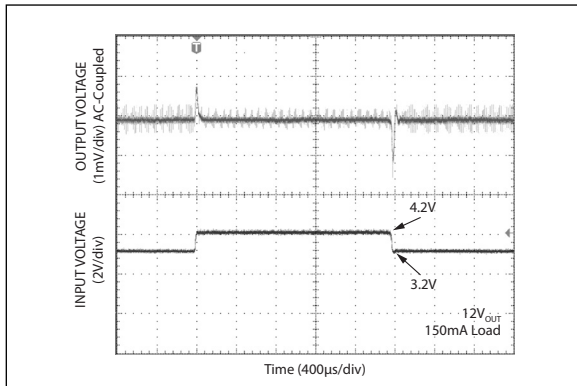

**FIGURE 2-14:** Line Transient Response.

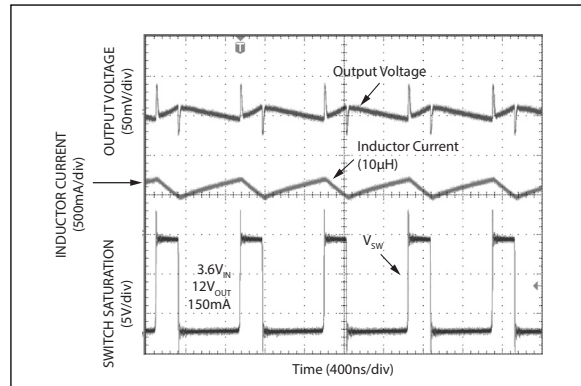

**FIGURE 2-16:** Output Voltage Ripple and Switching Waveforms.



## 3.0 PIN DESCRIPTIONS

The descriptions of the pins are listed in [Table 3-1](#).

**TABLE 3-1: PIN FUNCTION TABLE**

Pin Number TSOT23-5	Pin Number VDFN-8	Pin Name	Description
1	7	SW	Switch Node (Input): Internal power bipolar collector.
2	—	GND	Ground (Return): Ground.
3	6	FB	Feedback (Input): 1.24V output voltage sense node.
4	3	EN	Enable (input): Logic-high enables regulator. Logic-low shuts down regulator. Do not leave floating.
5	2	VIN	Supply (Input): 2.5V to 10V input voltage.
—	1	OVP	Output Overvoltage Protection (Input): Tie this pin to VOUT to clamp the output voltage to 34V maximum in fault conditions. Tie this pin to ground if OVP function is not required.
—	5	NC	No Connect: No internal connection to die.
—	4	AGND	Analog ground.
—	8	PGND	Power ground.
—	EP	GND	Exposed backside pad.

# MIC2288

---

## 4.0 FUNCTIONAL DESCRIPTION

The MIC2288 is a constant frequency, PWM current mode boost regulator. See the [Functional Block Diagram](#). The MIC2288 is composed of an oscillator, slope compensation ramp generator, current amplifier,  $g_m$  error amplifier, PWM generator, and a 1A bipolar output transistor. The oscillator generates a 1.2 MHz clock. The clock's two functions are to trigger the PWM generator that turns on the output transistor and to reset the slope compensation ramp generator. The current amplifier is used to measure the switch current by amplifying the voltage signal from the internal sense resistor. The output of the current amplifier is summed with the output of the slope compensation ramp generator. This summed current-loop signal is fed to one of the inputs of the PWM generator.

The  $g_m$  error amplifier measures the feedback voltage through the external feedback resistors and amplifies the error between the detected signal and the 1.24V reference voltage. The output of the  $g_m$  error amplifier provides the voltage-loop signal that is fed to the other input of the PWM generator. When the current-loop signal exceeds the voltage-loop signal, the PWM generator turns off the bipolar output transistor. The next clock period initiates the next switching cycle, maintaining the constant frequency current-mode PWM control.

## 5.0 APPLICATION INFORMATION

### 5.1 DC/DC PWM Boost Conversion

The MIC2288 is a constant-frequency boost converter. It operates by taking a DC input voltage and regulating a higher DC output voltage. Figure 5-1 shows a typical circuit. Boost regulation is achieved by turning on an internal switch, which draws current through the inductor (L1). When the switch turns off, the inductor's magnetic field collapses, causing the current to be discharged into the output capacitor through an external Schottky diode (D1). Voltage regulation is achieved by modulating the pulse width or pulse-width modulation (PWM).

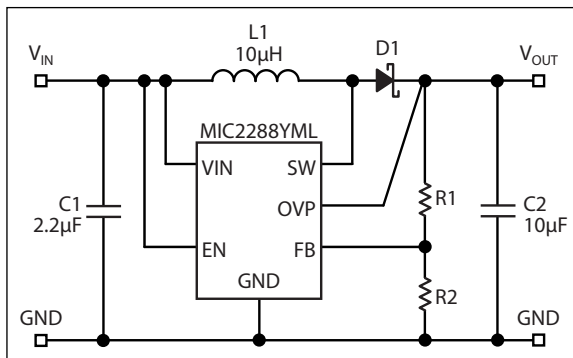

FIGURE 5-1: Typical Application Circuit.

### 5.2 Duty Cycle Considerations

Duty cycle refers to the switch on-to-off time ratio and can be calculated as follows for a boost regulator:

#### EQUATION 5-1:

$$D = 1 - \frac{V_{IN}}{V_{OUT}}$$

The duty cycle required for voltage conversion should be less than the maximum duty cycle of 85%. Also, in light load conditions where the input voltage is close to the output voltage, the minimum duty cycle can cause pulse skipping. This is due to the energy stored in the inductor causing the output to overshoot slightly over the regulated output voltage. During the next cycle, the error amplifier detects the output as being high and skips the following pulse. This effect can be reduced by increasing the minimum load or by increasing the inductor value. Increasing the inductor value reduces peak current, which in turn reduces energy transfer in each cycle.

### 5.3 Overvoltage Protection

For the VDFN package option, there is an overvoltage protection function. If the feedback resistors are disconnected from the circuit or the feedback pin is shorted to ground, the feedback pin will fall to ground potential. This will cause the MIC2288 to switch at full duty cycle in an attempt to maintain the feedback voltage. As a result, the output voltage will climb out of control. This may cause the switch node voltage to exceed its maximum voltage rating, possibly damaging the IC and the external components. To ensure the highest level of protection, the MIC2288 OVP pin will shut the switch off when an overvoltage condition is detected, saving the regulator and other sensitive circuitry downstream.

### 5.4 Component Selection

#### 5.4.1 INDUCTOR

Inductor selection is a balance between efficiency, stability, cost, size, and rated current. For most applications, 10 µH is the recommended inductor value. It is usually a good balance between these considerations.

Larger inductance values reduce the peak-to-peak ripple current, affecting efficiency. This has the effect of reducing both the DC losses and the transition losses. There is also a secondary effect of an inductor's DC resistance (DCR). The DCR of an inductor will be higher for more inductance in the same package size. This is due to the longer windings required for an increase in inductance. Because the majority of input current (minus the MIC2288 operating current) is passed through the inductor, higher DCR inductors will reduce efficiency.

To maintain stability, increasing the inductor value will have to be associated with an increase in output capacitance. This is due to the unavoidable "right half plane zero" effect for the continuous current boost converter topology. The frequency at which the right half plane zero occurs can be calculated as follows:

#### EQUATION 5-2:

$$f_{RHPZ} = \frac{V_{IN}^2}{V_{OUT} \times L \times I_{OUT} \times 2\pi}$$

The right half plane zero has the undesirable effect of increasing gain, while decreasing phase. This requires that the loop gain is rolled off before this has significant effect on the total loop response. This can be accomplished by either reducing inductance (increasing RHPZ frequency) or increasing the output capacitor value (decreasing loop gain).

# MIC2288

---

## 5.4.2 OUTPUT CAPACITOR

Output capacitor selection is also a trade-off between performance, size, and cost. Increasing output capacitance will lead to an improved transient response, but also an increase in size and cost. X5R or X7R dielectric ceramic capacitors are recommended for designs with the MIC2288. Y5V values may be used but to compensate their drift over temperature, more capacitance is required. The following table shows the recommended ceramic (X5R) output capacitor value vs. output voltage.

**TABLE 5-1: OUTPUT CAPACITOR SELECTION**

Output Voltage	Recommended Output Capacitance
<6V	22 $\mu$ F
<16V	10 $\mu$ F
<34V	4.7 $\mu$ F

## 5.4.3 DIODE SELECTION

The MIC2288 requires an external diode for operation. A Schottky diode is recommended for most applications due to their lower forward voltage drop and reverse recovery time. Ensure the diode selected can deliver the peak inductor current and the maximum reverse voltage is rated greater than the output voltage.

## 5.4.4 INPUT CAPACITOR

A minimum 1  $\mu$ F ceramic capacitor is recommended for designing with the MIC2288. Increasing input capacitance will improve performance and greater noise immunity on the source. The input capacitor should be as close as possible to the inductor and the MIC2288, with short traces for good noise performance.

## 5.4.5 FEEDBACK RESISTORS

The MIC2288 utilizes a feedback pin to compare the output to an internal reference. The output voltage is adjusted by selecting the appropriate feedback resistor network values. The R2 resistor value must be less than or equal to 5 k $\Omega$  ( $R2 \leq 5 \text{ k}\Omega$ ). The desired output voltage can be calculated as follows:

**EQUATION 5-3:**

$$V_{OUT} = V_{REF} \times \left( \frac{R1}{R2} + 1 \right)$$

Where:

$$V_{REF} = 1.24\text{V}$$

## 6.0 APPLICATION CIRCUITS

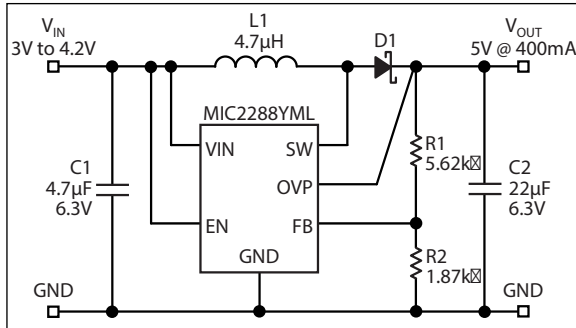

**FIGURE 6-1:** 3.0V to 4.2V  $V_{IN}$  to 5V $_{OUT}$  @ 400 mA.

Ref	Description	Part Number	Vendor
C1	4.7 $\mu$ F, 6.3V, 0805 X5R Cer Cap	08056D475MAT	AVX
C2	22 $\mu$ F, 6.3V, 0805 X5R Cer Cap	12066D226MAT	AVX
D1	1A, 40V Schottky Diode	MBRM140T3	On Semi.
L1	4.7 $\mu$ H, 650 mA Inductor	LQH32CN4R7M11	Murata

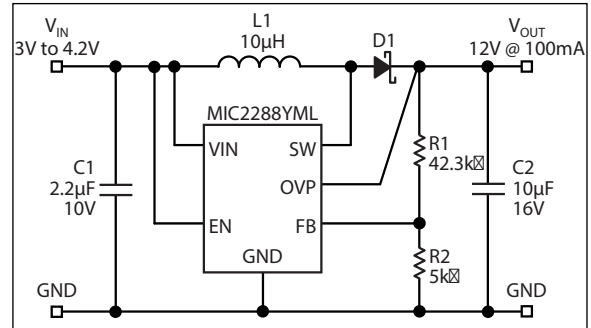

**FIGURE 6-3:** 3.0V to 4.2V  $V_{IN}$  to 12V $_{OUT}$  @ 100 mA.

Ref	Description	Part Number	Vendor
C1	4.7 $\mu$ F, 6.3V, 0805 X5R Cer Cap	08056D475MAT	AVX
C2	10 $\mu$ F, 16V, 1206 X5R Cer Cap	1206YD106MAT	AVX
D1	1A, 40V Schottky Diode	MBRM140T3	On Semi.
L1	4.7 $\mu$ H, 650 mA Inductor	LQH32CN4R7M11	Murata

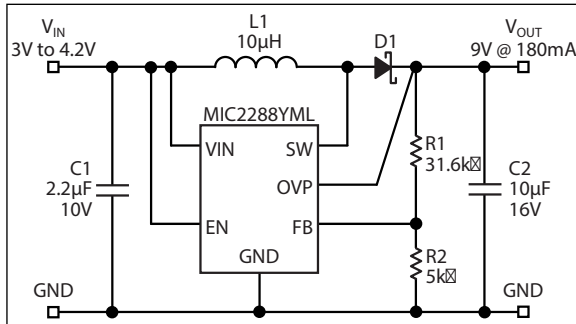

**FIGURE 6-2:** 3.0V to 4.2V  $V_{IN}$  to 9V $_{OUT}$  @ 180 mA.

Ref	Description	Part Number	Vendor
C1	2.2 $\mu$ F, 10V, 0805 X5R Cer Cap	08052D225KAT	AVX
C2	10 $\mu$ F, 16V, 1206 X5R Cer Cap	1206YD106MAT	AVX
D1	1A, 40V Schottky Diode	MBRM140T3	On Semi.
L1	10 $\mu$ H, 650 mA Inductor	LQH43CN100K03	Murata

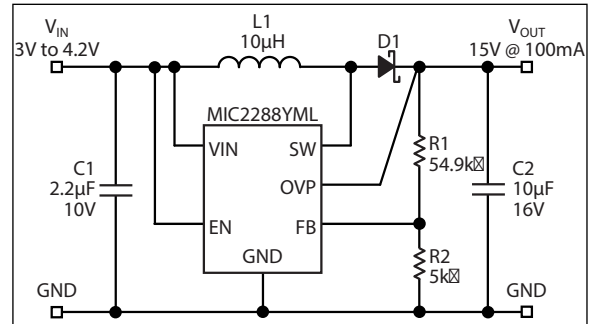

**FIGURE 6-4:** 3.0V to 4.2V  $V_{IN}$  to 15V $_{OUT}$  @ 100 mA.

Ref	Description	Part Number	Vendor
C1	2.2 $\mu$ F, 10V, 0805 X5R Cer Cap	08052D225KAT	AVX
C2	10 $\mu$ F, 16V, 1206 X5R Cer Cap	1206YD106MAT	AVX
D1	1A, 40V Schottky Diode	MBRM140T3	On Semi.
L1	10 $\mu$ H, 650 mA Inductor	LQH43CN100K03	Murata

# MIC2288

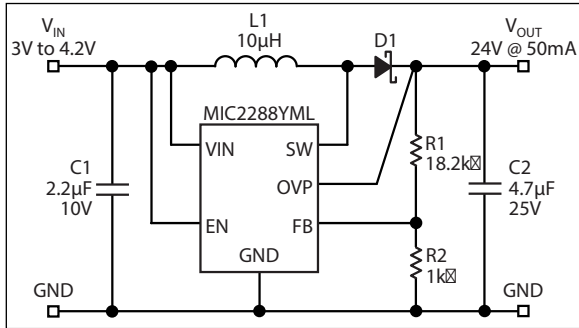

**FIGURE 6-5:** 3.0V to 4.2V  $V_{IN}$  to 24V  $V_{OUT}$  @ 50 mA.

Ref	Description	Part Number	Vendor
<b>C1</b>	2.2 $\mu$ F, 10V, 0805 X5R Cer Cap	08052D225KAT	AVX
<b>C2</b>	4.7 $\mu$ F, 25V, 1206 X5R Cer Cap	12063D475MAT	AVX
<b>D1</b>	1A, 40V Schottky Diode	MBRM140T3	On Semi.
<b>L1</b>	10 $\mu$ H, 650 mA Inductor	LQH43CN100K03	Murata

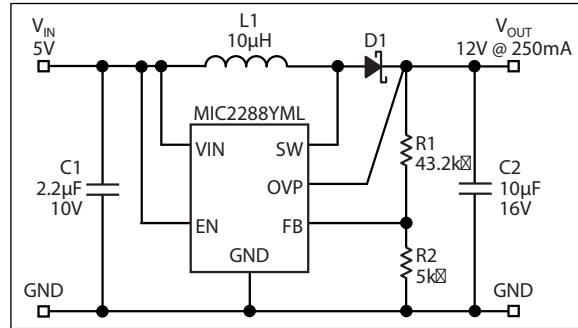

**FIGURE 6-7:** 5V  $V_{IN}$  to 12V  $V_{OUT}$  @ 250 mA.

Ref	Description	Part Number	Vendor
<b>C1</b>	2.2 $\mu$ F, 10V, 0805 X5R Cer Cap	08052D225KAT	AVX
<b>C2</b>	10 $\mu$ F, 16V, 1206 X5R Cer Cap	1206YD106MAT	AVX
<b>D1</b>	1A, 40V Schottky Diode	MBRM140T3	On Semi.
<b>L1</b>	10 $\mu$ H, 650 mA Inductor	LQH43CN100K03	Murata

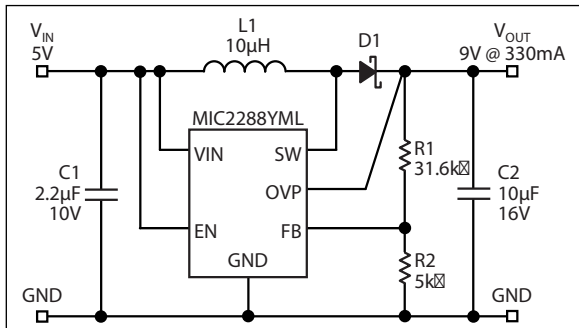

**FIGURE 6-6:** 5V  $V_{IN}$  to 9V  $V_{OUT}$  @ 330 mA.

Ref	Description	Part Number	Vendor
<b>C1</b>	2.2 $\mu$ F, 10V, 0805 X5R Cer Cap	08052D225KAT	AVX
<b>C2</b>	10 $\mu$ F, 16V, 1206 X5R Cer Cap	1206YD106MAT	AVX
<b>D1</b>	1A, 40V Schottky Diode	MBRM140T3	On Semi.
<b>L1</b>	10 $\mu$ H, 650 mA Inductor	LQH43CN100K03	Murata

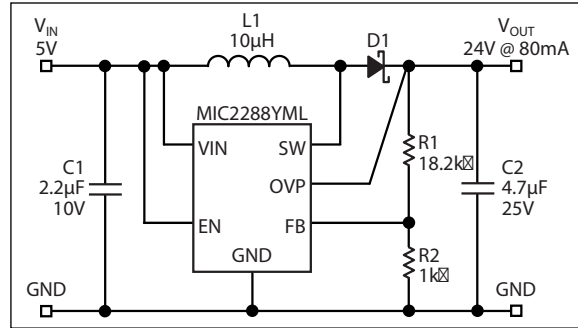

**FIGURE 6-8:** 5V  $V_{IN}$  to 24V  $V_{OUT}$  @ 80 mA.

Ref	Description	Part Number	Vendor
<b>C1</b>	2.2 $\mu$ F, 10V, 0805 X5R Cer Cap	08052D225KAT	AVX
<b>C2</b>	4.7 $\mu$ F, 25V, 1206 X5R Cer Cap	12066D475MAT	AVX
<b>D1</b>	1A, 40V Schottky Diode	MBRM140T3	On Semi.
<b>L1</b>	10 $\mu$ H, 650 mA Inductor	LQH43CN100K03	Murata

## 7.0 PACKAGING INFORMATION

### 7.1 Package Marking Information

5-Lead TSOT23\*  
(Front)

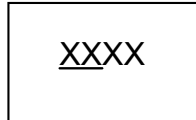

Example

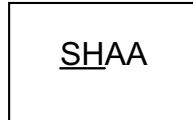

5-Lead TSOT23\*  
(Back)

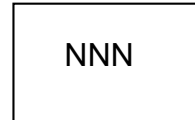

Example

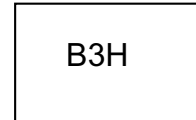

8-Lead VDFN\*

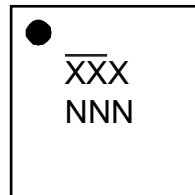

Example

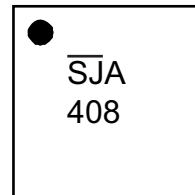

<b>Legend:</b>	XX...X	Product code or customer-specific information
	Y	Year code (last digit of calendar year)
	YY	Year code (last 2 digits of calendar year)
	WW	Week code (week of January 1 is week '01')
	NNN	Alphanumeric traceability code
	(e3)	Pb-free JEDEC® designator for Matte Tin (Sn)
	*	This package is Pb-free. The Pb-free JEDEC designator ((e3)) can be found on the outer packaging for this package.
	●, ▲, ▼	Pin one index is identified by a dot, delta up, or delta down (triangle mark).
<b>Note:</b>	In the event the full Microchip part number cannot be marked on one line, it will be carried over to the next line, thus limiting the number of available characters for customer-specific information. Package may or may not include the corporate logo.	
	Underbar (¯) and/or Overbar (¯) symbol may not be to scale.	

**Note:** If the full seven-character YYWWNNN code cannot fit on the package, the following truncated codes are used based on the available marking space:

6 Characters = YWWNNN; 5 Characters = WWNNN; 4 Characters = WNNN; 3 Characters = NNN;  
2 Characters = NN; 1 Character = N

## 5-Lead Plastic Thin Small Outline Transistor (D5A) [TSOT] Micrel Legacy Package TSOT-5LD-PL-1

**Note:** For the most current package drawings, please see the Microchip Packaging Specification located at <http://www.microchip.com/packaging>

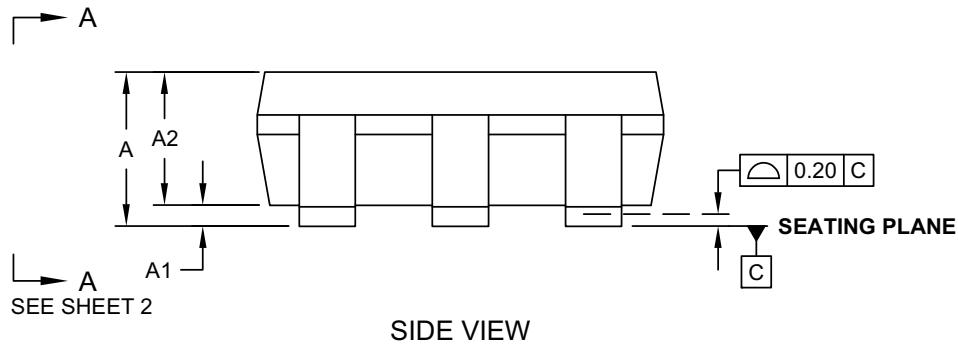
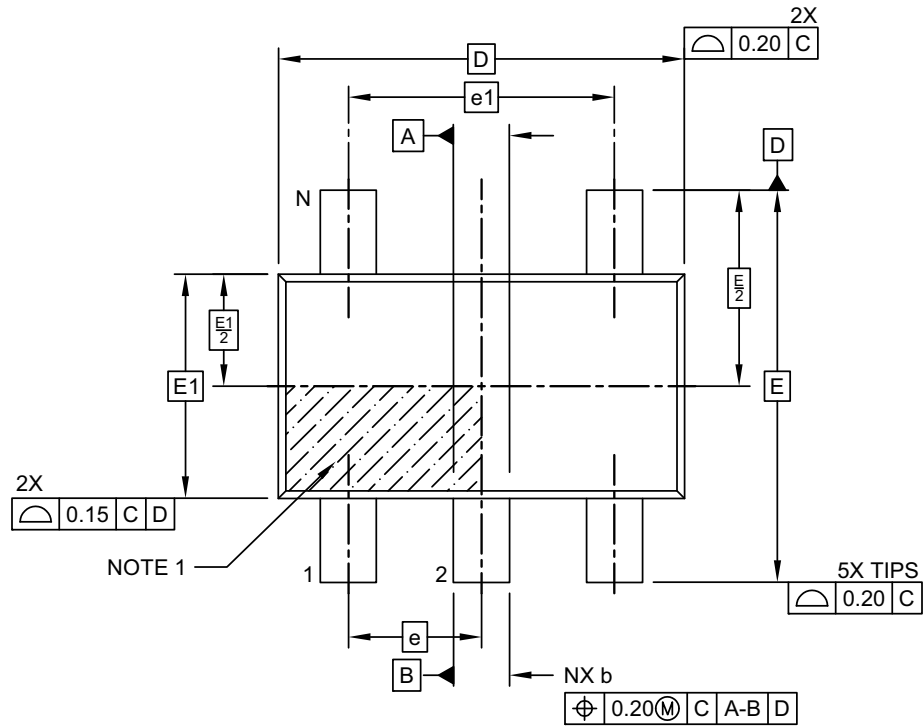

Microchip Technology Drawing C04-1179 Rev A Sheet 1 of 2



## 5-Lead Plastic Thin Small Outline Transistor (D5A) [TSOT] Micrel Legacy Package TSOT-5LD-PL-1

**Note:** For the most current package drawings, please see the Microchip Packaging Specification located at <http://www.microchip.com/packaging>

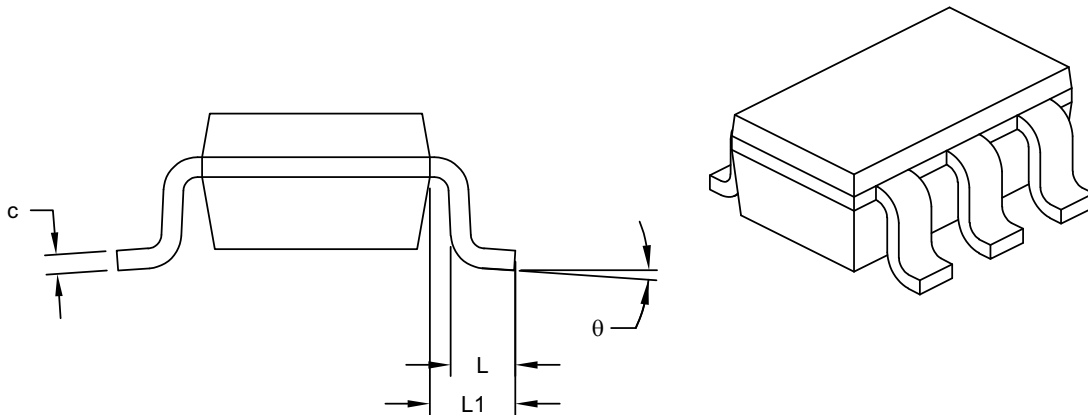

VIEW A-A  
SHEET 1

Dimension Limits	Units	MILLIMETERS		
		MIN	NOM	MAX
Number of Leads	N	5		
Pitch	e	0.95 BSC		
Outside lead pitch	e1	1.90 BSC		
Overall Height	A	-	-	1.00
Molded Package Thickness	A2	0.84	0.87	0.90
Standoff	A1	0.00	-	0.10
Overall Width	E	2.80 BSC		
Molded Package Width	E1	1.60 BSC		
Overall Length	D	2.90 BSC		
Foot Length	L	0.30	0.40	0.50
Footprint	L1	0.60 REF		
Foot Angle	φ	0°	-	4°
Lead Thickness	c	0.127 REF		
Lead Width	b	0.30	-	0.50

**Notes:**

- Dimensions D and E1 do not include mold flash or protrusions. Mold flash or protrusions shall not exceed 0.25mm per side.
- Dimensioning and tolerancing per ASME Y14.5M  
BSC: Basic Dimension. Theoretically exact value shown without tolerances.  
REF: Reference Dimension, usually without tolerance, for information purposes only.

Microchip Technology Drawing C04-1179 Rev A Sheet 1 of 2

## 5-Lead Plastic Thin Small Outline Transistor (D5A) [TSOT] Micrel Legacy Package TSOT-5LD-PL-1

**Note:** For the most current package drawings, please see the Microchip Packaging Specification located at <http://www.microchip.com/packaging>

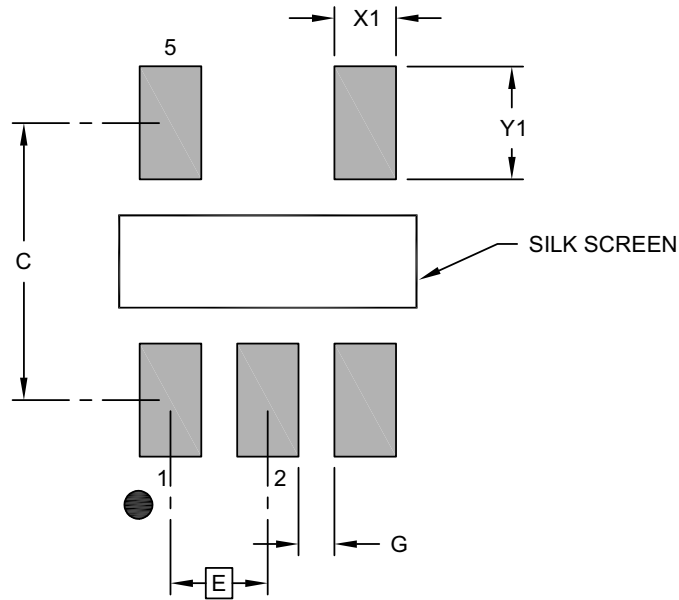

### RECOMMENDED LAND PATTERN

Dimension Limits	Units	MILLIMETERS		
		MIN	NOM	MAX
Contact Pitch	E	0.95 BSC		
Contact Pad Spacing	C		2.60	
Contact Pad Width (X5)	X1			0.60
Contact Pad Length (X5)	Y1			1.10
Contact Pad to Center Pad (X2)	G	0.20		

**Notes:**

1. Dimensioning and tolerancing per ASME Y14.5M  
BSC: Basic Dimension. Theoretically exact value shown without tolerances.

Microchip Technology Drawing C04-3179 Rev A

## 8-Lead Very Thin Plastic Dual Flat, No Lead Package (H2A) - 2x2x0.9 mm Body [VDFN] With 1.20x0.6 mm Exposed Pad

**Note:** For the most current package drawings, please see the Microchip Packaging Specification located at <http://www.microchip.com/packaging>

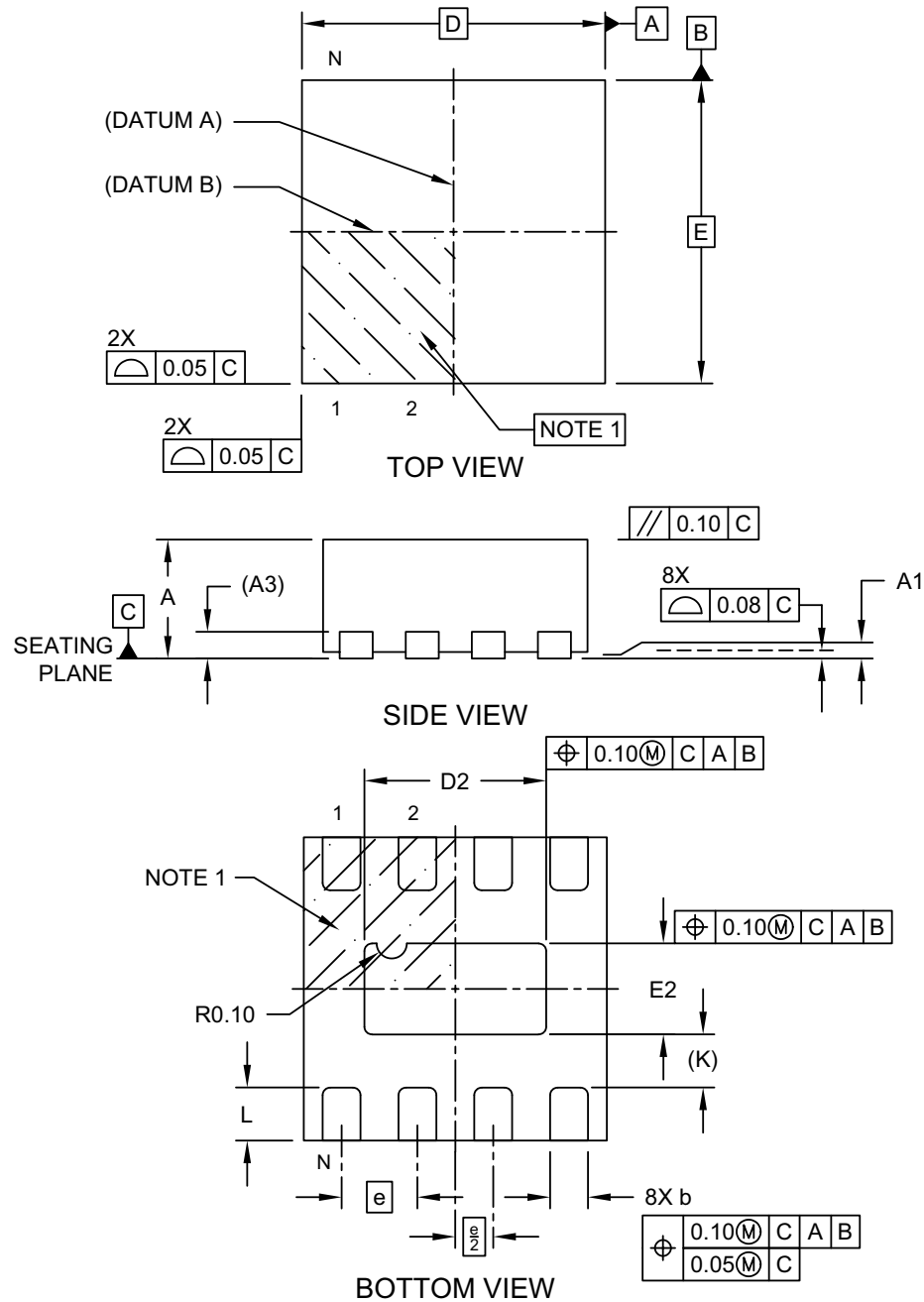

Microchip Technology Drawing C04-1247 Rev A Sheet 1 of 2

# MIC2288

## 8-Lead Very Thin Plastic Dual Flat, No Lead Package (H2A) - 2x2x.9 mm Body [VDFN] With 1.20x0.6 mm Exposed Pad

**Note:** For the most current package drawings, please see the Microchip Packaging Specification located at <http://www.microchip.com/packaging>

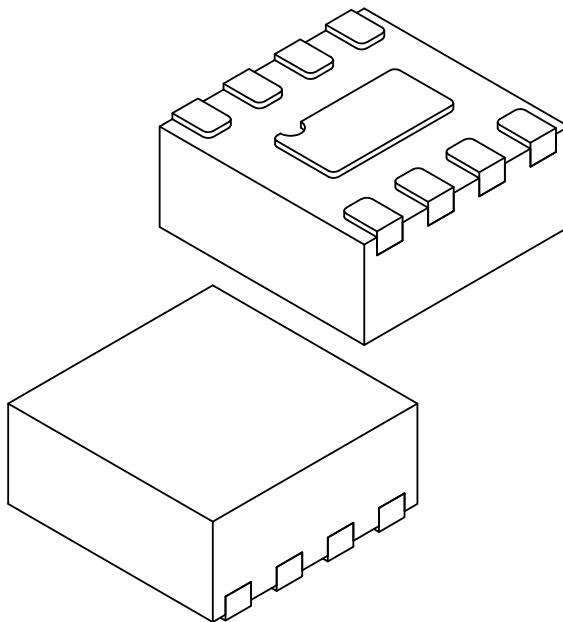

Dimension Limits	Units	MILLIMETERS		
		MIN	NOM	MAX
Number of Terminals	N	8		
Pitch	e	0.50 BSC		
Overall Height	A	0.80	0.85	0.90
Standoff	A1	0.00	0.02	0.05
Terminal Thickness	A3	0.203 REF		
Overall Length	D	2.00 BSC		
Exposed Pad Length	D2	1.10	1.20	1.30
Overall Width	E	2.00 BSC		
Exposed Pad Width	E2	0.50	0.60	0.70
Terminal Width	b	0.20	0.25	0.30
Terminal Length	L	0.30	0.35	0.40
Terminal-to-Exposed-Pad	K	0.35 REF		

**Notes:**

1. Pin 1 visual index feature may vary, but must be located within the hatched area.
2. Package is saw singulated
3. Dimensioning and tolerancing per ASME Y14.5M  
BSC: Basic Dimension. Theoretically exact value shown without tolerances.  
REF: Reference Dimension, usually without tolerance, for information purposes only.

Microchip Technology Drawing C04-1247 Rev A Sheet 2 of 2

## 8-Lead Very Thin Plastic Dual Flat, No Lead Package (H2A) - 2x2 mm Body [VDFN] Micrel Legacy Package

**Note:** For the most current package drawings, please see the Microchip Packaging Specification located at <http://www.microchip.com/packaging>

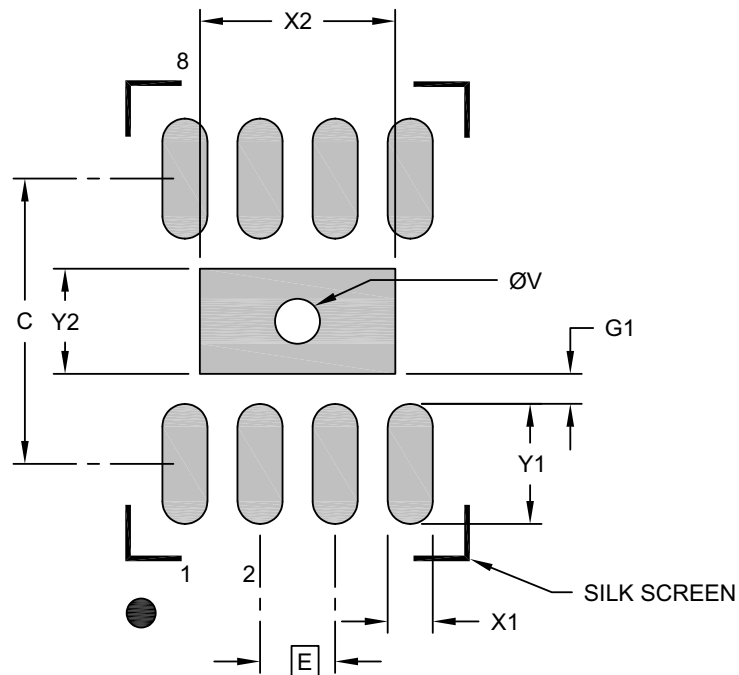

RECOMMENDED LAND PATTERN

Dimension Limits	Units	MILLIMETERS		
		MIN	NOM	MAX
Contact Pitch	E	0.50 BSC		
Optional Center Pad Width	X2			0.70
Optional Center Pad Length	Y2			1.30
Contact Pad Spacing	C		1.90	
Contact Pad Width (X8)	X1			0.30
Contact Pad Length (X8)	Y1			0.80
Contact Pad to Center Pad (X8)	G1	0.20		
Thermal Via Diameter	V		0.30	

**Notes:**

1. Dimensioning and tolerancing per ASME Y14.5M  
BSC: Basic Dimension. Theoretically exact value shown without tolerances.
2. For best soldering results, thermal vias, if used, should be filled or tented to avoid solder loss during reflow process

Microchip Technology Drawing C04-3247 Rev. A

# MIC2288

---

NOTES:

## APPENDIX A: REVISION HISTORY

### Revision A (May 2018)

- Converted Micrel document MIC2288 to Microchip data sheet template DS20006034A.
- Minor grammatical text changes throughout.
- Updated Low Output Voltage Ripple in [Features](#).
- Added clarification to EN description in [Table 3-1](#).
- Updated drawing for EN in [Figure 5-1](#).
- Updated drawings and figure captions for each entry in [Section 6.0 “Application Circuits”](#).

### Revision B (September 2018)

- Updated values for C2 in the table beneath [Figure 6-3](#).

### Revision C (July 2023)

- Corrected the part number for L1 in the table beneath [Figure 6-8](#).
- Updated both Package Outline Drawings with the most current Microchip versions.

# MIC2288

---

NOTES:



## PRODUCT IDENTIFICATION SYSTEM

To order or obtain information, e.g., on pricing or delivery, contact your local Microchip representative or sales office.

Device	<u>X</u>	<u>XX</u>	<u>-XX</u>	Examples:
Part No.	Junction Temp. Range	Package	Media Type	
<b>Device:</b>	MIC2288:	1A, 1.2 MHz PWM Boost Converter		a) MIC2288YD5-TX: MIC2288, -40°C to +125°C Temperature Range, 5-Lead TSOT23, 3,000/Reel (Reverse T/R)
<b>Junction Temperature Range:</b>	Y =	-40°C to +125°C, RoHS-Compliant		b) MIC2288YD5-TR: MIC2288, -40°C to +125°C Temperature Range, 5-Lead TSOT, 3,000/Reel
<b>Package:</b>	D5 =	5-Lead Thin SOT23		c) MIC2288YML-TR: MIC2288, -40°C to +125°C Temperature Range, 8-Lead VDFN, 5,000/Reel
	ML =	8-Lead 2 mm x 2 mm VDFN		<b>Note 1:</b> Tape and Reel identifier only appears in the catalog part number description. This identifier is used for ordering purposes and is not printed on the device package. Check with your Microchip Sales Office for package availability with the Tape and Reel option.
<b>Media Type:</b>	TX =	3,000/Reel (Reverse T/R, TSOT only)		
	TR =	3,000/Reel (TSOT only)		
	TR =	5,000/Reel (VDFN only)		

# MIC2288

---

NOTES:

---

---

**Note the following details of the code protection feature on Microchip products:**

- Microchip products meet the specifications contained in their particular Microchip Data Sheet.
- Microchip believes that its family of products is secure when used in the intended manner, within operating specifications, and under normal conditions.
- Microchip values and aggressively protects its intellectual property rights. Attempts to breach the code protection features of Microchip product is strictly prohibited and may violate the Digital Millennium Copyright Act.
- Neither Microchip nor any other semiconductor manufacturer can guarantee the security of its code. Code protection does not mean that we are guaranteeing the product is "unbreakable" Code protection is constantly evolving. Microchip is committed to continuously improving the code protection features of our products.

---

This publication and the information herein may be used only with Microchip products, including to design, test, and integrate Microchip products with your application. Use of this information in any other manner violates these terms. Information regarding device applications is provided only for your convenience and may be superseded by updates. It is your responsibility to ensure that your application meets with your specifications. Contact your local Microchip sales office for additional support or, obtain additional support at <https://www.microchip.com/en-us/support/design-help/client-support-services>.

THIS INFORMATION IS PROVIDED BY MICROCHIP "AS IS". MICROCHIP MAKES NO REPRESENTATIONS OR WARRANTIES OF ANY KIND WHETHER EXPRESS OR IMPLIED, WRITTEN OR ORAL, STATUTORY OR OTHERWISE, RELATED TO THE INFORMATION INCLUDING BUT NOT LIMITED TO ANY IMPLIED WARRANTIES OF NON-INFRINGEMENT, MERCHANTABILITY, AND FITNESS FOR A PARTICULAR PURPOSE, OR WARRANTIES RELATED TO ITS CONDITION, QUALITY, OR PERFORMANCE.

IN NO EVENT WILL MICROCHIP BE LIABLE FOR ANY INDIRECT, SPECIAL, PUNITIVE, INCIDENTAL, OR CONSEQUENTIAL LOSS, DAMAGE, COST, OR EXPENSE OF ANY KIND WHATSOEVER RELATED TO THE INFORMATION OR ITS USE, HOWEVER CAUSED, EVEN IF MICROCHIP HAS BEEN ADVISED OF THE POSSIBILITY OR THE DAMAGES ARE FORESEEABLE. TO THE FULLEST EXTENT ALLOWED BY LAW, MICROCHIP'S TOTAL LIABILITY ON ALL CLAIMS IN ANY WAY RELATED TO THE INFORMATION OR ITS USE WILL NOT EXCEED THE AMOUNT OF FEES, IF ANY, THAT YOU HAVE PAID DIRECTLY TO MICROCHIP FOR THE INFORMATION.

Use of Microchip devices in life support and/or safety applications is entirely at the buyer's risk, and the buyer agrees to defend, indemnify and hold harmless Microchip from any and all damages, claims, suits, or expenses resulting from such use. No licenses are conveyed, implicitly or otherwise, under any Microchip intellectual property rights unless otherwise stated.

For information regarding Microchip's Quality Management Systems, please visit [www.microchip.com/quality](http://www.microchip.com/quality).

**Trademarks**

The Microchip name and logo, the Microchip logo, Adaptec, AVR, AVR logo, AVR Freaks, BesTime, BitCloud, CryptoMemory, CryptoRF, dsPIC, flexPWR, HELDO, IGLoo, JukeBlox, KeeLoq, Klear, LANCheck, LinkMD, maXStylus, maXTouch, MediaLB, megaAVR, Microsemi, Microsemi logo, MOST, MOST logo, MPLAB, OptoLyzer, PIC, picoPower, PICSTART, PIC32 logo, PolarFire, Prochip Designer, QTouch, SAM-BA, SenGenuity, SpyNIC, SST, SST Logo, SuperFlash, Symmetricom, SyncServer, Tachyon, TimeSource, tinyAVR, UNI/O, Vectron, and XMEGA are registered trademarks of Microchip Technology Incorporated in the U.S.A. and other countries.

AgileSwitch, APT, ClockWorks, The Embedded Control Solutions Company, EtherSynch, Flashtec, Hyper Speed Control, HyperLight Load, Libero, motorBench, mTouch, Powermite 3, Precision Edge, ProASIC, ProASIC Plus, ProASIC Plus logo, Quiet-Wire, SmartFusion, SyncWorld, Temux, TimeCesium, TimeHub, TimePictra, TimeProvider, TrueTime, and ZL are registered trademarks of Microchip Technology Incorporated in the U.S.A.

Adjacent Key Suppression, AKS, Analog-for-the-Digital Age, Any Capacitor, AnyIn, AnyOut, Augmented Switching, BlueSky, BodyCom, Clockstudio, CodeGuard, CryptoAuthentication, CryptoAutomotive, CryptoCompanion, CryptoController, dsPICDEM, dsPICDEM.net, Dynamic Average Matching, DAM, ECAN, Espresso T1S, EtherGREEN, GridTime, IdealBridge, In-Circuit Serial Programming, ICSP, INICnet, Intelligent Paralleling, IntelliMOS, Inter-Chip Connectivity, JitterBlocker, Knob-on-Display, KoD, maxCrypto, maxView, memBrain, Mindi, MiWi, MPASM, MPF, MPLAB Certified logo, MPLIB, MPLINK, MultiTRAK, NetDetach, Omniscient Code Generation, PICDEM, PICDEM.net, PICkit, PICtail, PowerSmart, PureSilicon, QMatrix, REAL ICE, Ripple Blocker, RTAX, RTG4, SAM-ICE, Serial Quad I/O, simpleMAP, SimpliPHY, SmartBuffer, SmartHLS, SMART-I.S., storClad, SQI, SuperSwitcher, SuperSwitcher II, Switchtec, SynchroPHY, Total Endurance, Trusted Time, TSHARC, USBCheck, VariSense, VectorBlox, VeriPHY, ViewSpan, WiperLock, XpressConnect, and ZENA are trademarks of Microchip Technology Incorporated in the U.S.A. and other countries.

SQTP is a service mark of Microchip Technology Incorporated in the U.S.A.

The Adaptec logo, Frequency on Demand, Silicon Storage Technology, and Symmcom are registered trademarks of Microchip Technology Inc. in other countries.

GestIC is a registered trademark of Microchip Technology Germany II GmbH & Co. KG, a subsidiary of Microchip Technology Inc., in other countries.

All other trademarks mentioned herein are property of their respective companies.

© 2018 - 2023, Microchip Technology Incorporated and its subsidiaries.

All Rights Reserved.

ISBN: 978-1-6683-2844-6



# MICROCHIP

## Worldwide Sales and Service

### AMERICAS

**Corporate Office**  
2355 West Chandler Blvd.  
Chandler, AZ 85224-6199  
Tel: 480-792-7200  
Fax: 480-792-7277  
Technical Support:  
<http://www.microchip.com/support>  
Web Address:  
[www.microchip.com](http://www.microchip.com)

**Atlanta**  
Duluth, GA  
Tel: 678-957-9614  
Fax: 678-957-1455

**Austin, TX**  
Tel: 512-257-3370

**Boston**  
Westborough, MA  
Tel: 774-760-0087  
Fax: 774-760-0088

**Chicago**  
Itasca, IL  
Tel: 630-285-0071  
Fax: 630-285-0075

**Dallas**  
Addison, TX  
Tel: 972-818-7423  
Fax: 972-818-2924

**Detroit**  
Novi, MI  
Tel: 248-848-4000

**Houston, TX**  
Tel: 281-894-5983

**Indianapolis**  
Noblesville, IN  
Tel: 317-773-8323  
Fax: 317-773-5453  
Tel: 317-536-2380

**Los Angeles**  
Mission Viejo, CA  
Tel: 949-462-9523  
Fax: 949-462-9608  
Tel: 951-273-7800

**Raleigh, NC**  
Tel: 919-844-7510

**New York, NY**  
Tel: 631-435-6000

**San Jose, CA**  
Tel: 408-735-9110  
Tel: 408-436-4270

**Canada - Toronto**  
Tel: 905-695-1980  
Fax: 905-695-2078

### ASIA/PACIFIC

**Australia - Sydney**  
Tel: 61-2-9868-6733

**China - Beijing**  
Tel: 86-10-8569-7000

**China - Chengdu**  
Tel: 86-28-8665-5511

**China - Chongqing**  
Tel: 86-23-8980-9588

**China - Dongguan**  
Tel: 86-769-8702-9880

**China - Guangzhou**  
Tel: 86-20-8755-8029

**China - Hangzhou**  
Tel: 86-571-8792-8115

**China - Hong Kong SAR**  
Tel: 852-2943-5100

**China - Nanjing**  
Tel: 86-25-8473-2460

**China - Qingdao**  
Tel: 86-532-8502-7355

**China - Shanghai**  
Tel: 86-21-3326-8000

**China - Shenyang**  
Tel: 86-24-2334-2829

**China - Shenzhen**  
Tel: 86-755-8864-2200

**China - Suzhou**  
Tel: 86-186-6233-1526

**China - Wuhan**  
Tel: 86-27-5980-5300

**China - Xian**  
Tel: 86-29-8833-7252

**China - Xiamen**  
Tel: 86-592-2388138

**China - Zhuhai**  
Tel: 86-756-3210040

### ASIA/PACIFIC

**India - Bangalore**  
Tel: 91-80-3090-4444

**India - New Delhi**  
Tel: 91-11-4160-8631

**India - Pune**  
Tel: 91-20-4121-0141

**Japan - Osaka**  
Tel: 81-6-6152-7160

**Japan - Tokyo**  
Tel: 81-3-6880-3770

**Korea - Daegu**  
Tel: 82-53-744-4301

**Korea - Seoul**  
Tel: 82-2-554-7200

**Malaysia - Kuala Lumpur**  
Tel: 60-3-7651-7906

**Malaysia - Penang**  
Tel: 60-4-227-8870

**Philippines - Manila**  
Tel: 63-2-634-9065

**Singapore**  
Tel: 65-6334-8870

**Taiwan - Hsin Chu**  
Tel: 886-3-577-8366

**Taiwan - Kaohsiung**  
Tel: 886-7-213-7830

**Taiwan - Taipei**  
Tel: 886-2-2508-8600

**Thailand - Bangkok**  
Tel: 66-2-694-1351

**Vietnam - Ho Chi Minh**  
Tel: 84-28-5448-2100

### EUROPE

**Austria - Wels**  
Tel: 43-7242-2244-39  
Fax: 43-7242-2244-393

**Denmark - Copenhagen**  
Tel: 45-4485-5910  
Fax: 45-4485-2829

**Finland - Espoo**  
Tel: 358-9-4520-820

**France - Paris**  
Tel: 33-1-69-53-63-20  
Fax: 33-1-69-30-90-79

**Germany - Garching**  
Tel: 49-8931-9700

**Germany - Haan**  
Tel: 49-2129-3766400

**Germany - Heilbronn**  
Tel: 49-7131-72400

**Germany - Karlsruhe**  
Tel: 49-721-625370

**Germany - Munich**  
Tel: 49-89-627-144-0  
Fax: 49-89-627-144-44

**Germany - Rosenheim**  
Tel: 49-8031-354-560

**Israel - Ra'anana**  
Tel: 972-9-744-7705

**Italy - Milan**  
Tel: 39-0331-742611  
Fax: 39-0331-466781

**Italy - Padova**  
Tel: 39-049-7625286

**Netherlands - Drunen**  
Tel: 31-416-690399  
Fax: 31-416-690340

**Norway - Trondheim**  
Tel: 47-7288-4388

**Poland - Warsaw**  
Tel: 48-22-3325737

**Romania - Bucharest**  
Tel: 40-21-407-87-50

**Spain - Madrid**  
Tel: 34-91-708-08-90  
Fax: 34-91-708-08-91

**Sweden - Gothenberg**  
Tel: 46-31-704-60-40

**Sweden - Stockholm**  
Tel: 46-8-5090-4654

**UK - Wokingham**  
Tel: 44-118-921-5800  
Fax: 44-118-921-5820