

3A, Pin Strapping Power Module with HyperLight Load[®] Mode and Output Voltage Select

Features

- 2.4V to 5.5V Input Voltage Range
- 3A Output Current
- Pin Strapping Voltage Selection:
 - Three-state pins (nine voltage combinations)
 - 0.6V, 0.8V, 0.9V, 1.0V, 1.2V, 1.5V, 1.8V, 2.5V or 3.3V output voltage
- Passes Automotive AEC-Q104 Reliability Testing
- Reduced Component Count (no feedback resistors)
- High Efficiency (up to 95%)
- Output Discharge when Disabled
- Constant On-Time Control with High Switching Frequency:
 - 1.2 MHz typical at 1.0V output voltage
- $\pm 1.5\%$ Output Voltage Accuracy Over Line/Load/Temperature Range
- 0.8 ms/V Soft Start Speed
- Supports Safe Start-up with Pre-Biased Output
- Typical 1.5 μ A Shutdown Supply Current
- Low Dropout Operation (100% duty cycle)
- Ultra Fast Transient Response
- Latch-Off Thermal Shutdown Protection
- Latch-Off Current Limit Protection
- Power Good (PG) Open-Drain Output
- Meets **CISPR32 Class B** Radiated EMI
- Meets **CISPR 25 Class 5** Radiated EMI
- Package: 3.0 mm \times 4.5 mm \times 1.8 mm, 24-Lead QFN

Applications

- Solid State Drives (SSD)
- Tablets, Netbooks and Ultrabooks
- FPGAs, DSP and Low-Voltage ASIC Power

General Description

The MIC33M350 device is a pin-selectable output voltage, high-efficiency, low-voltage input, 3A current, synchronous step-down regulator power module with integrated inductor. The Constant On-Time (COT) control architecture with HyperLight Load provides very high efficiency at light loads, while maintaining an ultra-fast transient response.

The MIC33M350 output voltage is set by two V_{SEL} (Voltage Selection) pins, between nine different values. This method eliminates the need for an external feedback resistor divider and improves the output voltage setting accuracy.

The 2.4V to 5.5V input voltage range, low shutdown and quiescent currents make the MIC33M350 device ideal for single cell Li-Ion battery-powered applications. The 100% duty cycle capability provides Low Dropout operation, extending operating range in portable systems.

The MIC33M350 pinout is compatible with the MIC33M356 I²C-based programmable regulator version, such that applications can be easily converted. An open-drain Power Good output is provided to indicate when the output voltage is within 9% of regulation and facilitates the interface with an MCU. If set in shutdown (EN = GND), the MIC33M350 typically draws 1.5 μ A, while the output is discharged through 10 Ω pull-down.

MIC33M350 is available in a thermally efficient package: 24-Lead 3.0 mm \times 4.5 mm \times 1.8 mm QFN package, with an operating junction temperature range from -40°C to +125°C.

MIC33M350 passes Automotive AEC-Q104 Reliability Testing.

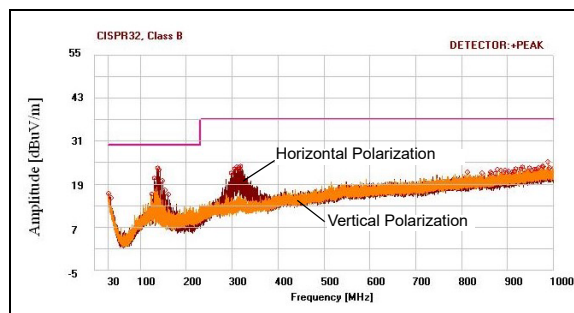

FIGURE 1: Radiated Emissions, CISPR32, Class B ($V_{IN} = 5V$, $V_{OUT} = 1V$, $I_{OUT} = 3A$).

MIC33M350

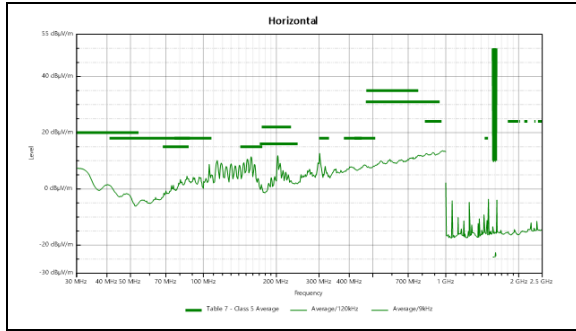

FIGURE 2: Radiated Emissions, Horizontal Polarization Average, CISPR25, Class 5 ($V_{IN} = 5V$, $V_{OUT} = 1V$, $I_{OUT} = 3A$).

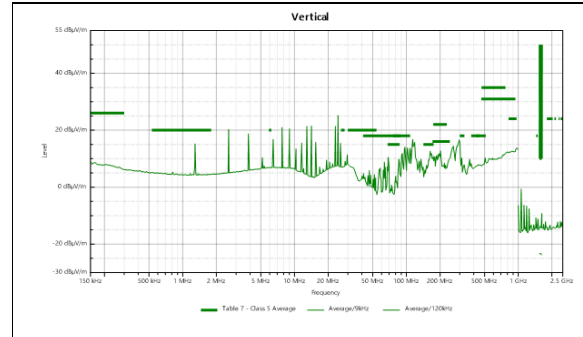
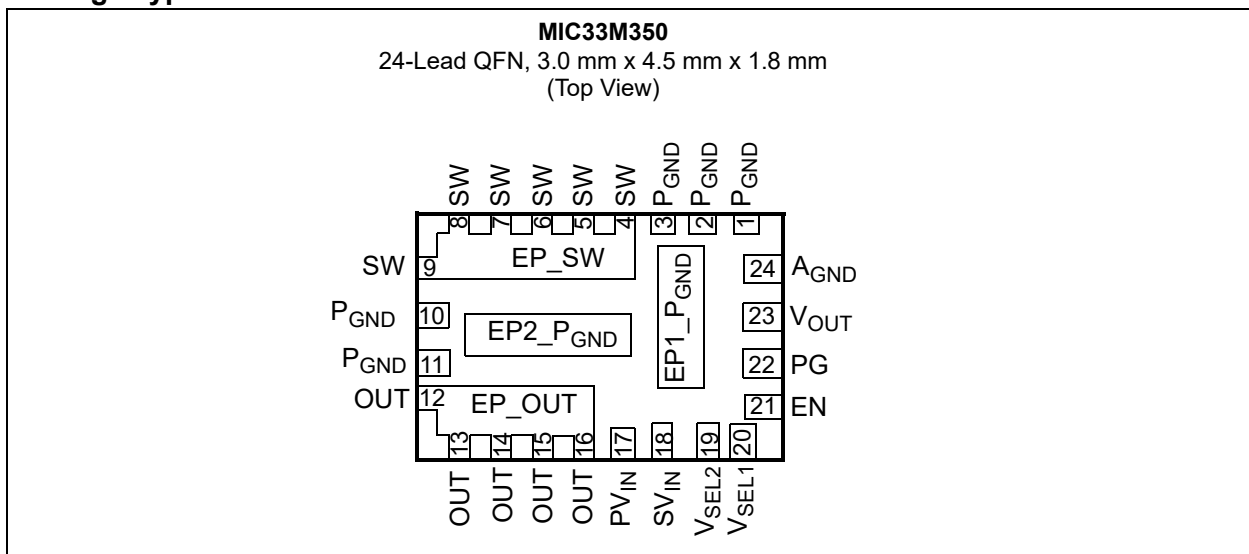
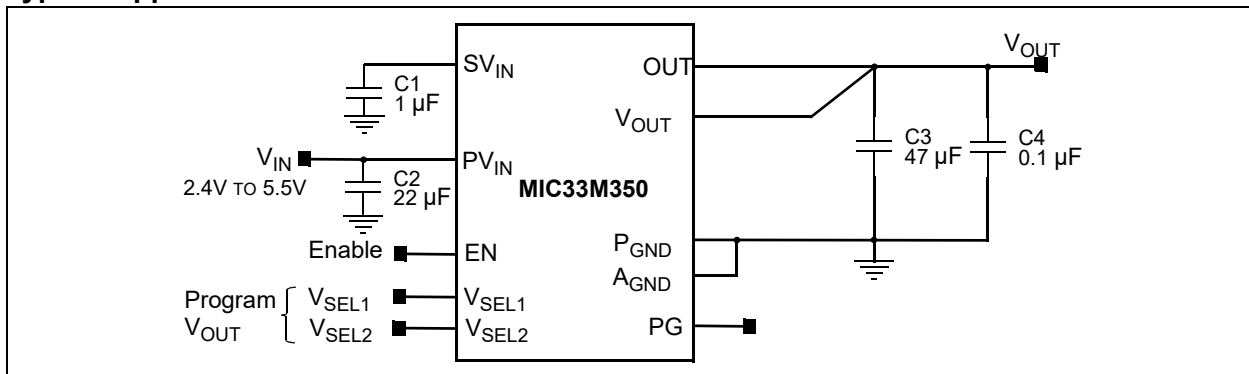

FIGURE 3: Radiated Emissions, Vertical Polarization Average, CISPR25, Class 5 ($V_{IN} = 5V$, $V_{OUT} = 1V$, $I_{OUT} = 3A$).

Package Type



Typical Application



Functional Block Diagram

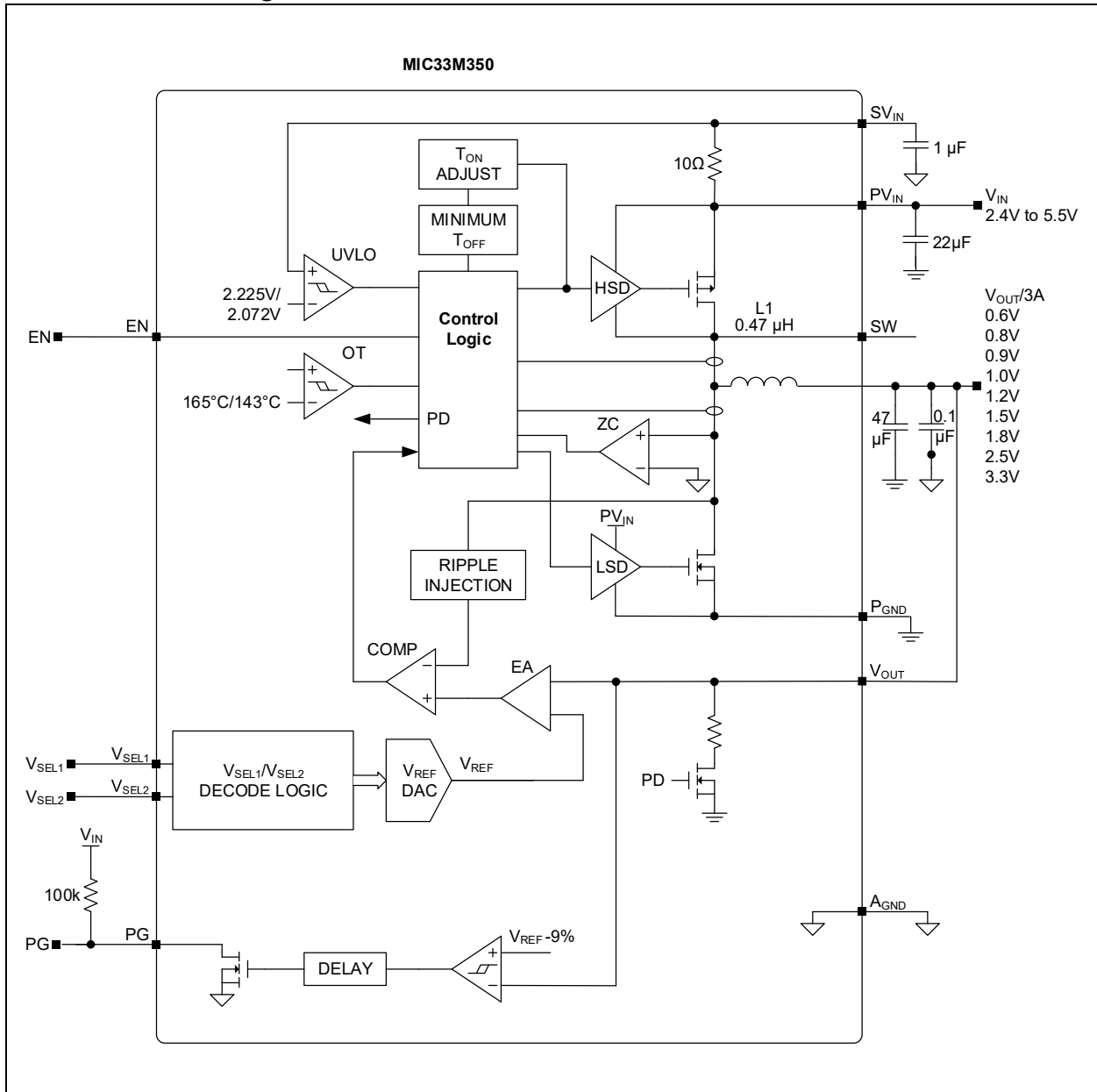

MIC33M350

NOTES:

1.0 ELECTRICAL CHARACTERISTICS

Absolute Maximum Ratings†

S_{VIN} , P_{VIN} to A_{GND}	-0.3V to +6V
V_{SW} to A_{GND}	-0.3V to +6V
V_{EN} to A_{GND}	-0.3V to P_{VIN}
V_{PG} to A_{GND}	-0.3V to P_{VIN}
V_{VSEL1} , V_{VSEL2} to A_{GND}	-0.3V to P_{VIN}
P_{VIN} to S_{VIN}	-0.3V to +0.3V
A_{GND} to P_{GND}	-0.3V to +0.3V
Junction Temperature	+150°C
Storage Temperature (T_S)	-65°C to +150°C
Lead Temperature (soldering, 10s)	+260°C
ESD Rating ⁽¹⁾	
HBM	2000V
CDM	1500V

† **Notice:** Stresses above those listed under “Maximum Ratings” may cause permanent damage to the device. This is a stress rating only and functional operation of the device at those or any other conditions above those indicated in the operational sections of this specification is not intended. Exposure to maximum rating conditions for extended periods may affect device reliability.

Note 1: Devices are ESD-sensitive. Handling precautions recommended. Human body model, 1.5 k Ω in series with 100 pF.

Operating Ratings⁽¹⁾

Supply Voltage (P_{VIN})	2.4V to 5.5V
Enable Voltage (V_{EN})	0V to P_{VIN}
Power Good (PG) Pull-up Voltage (V_{PU_PG})	0V to 5.5V
Maximum Output Current	3A
Junction Temperature (T_J)	-40°C to +125°C

Note 1: The device is not ensured to function outside the operating range.

MIC33M350

ELECTRICAL CHARACTERISTICS (1)

Electrical Specifications: Unless otherwise specified, $PV_{IN} = 5V$; $V_{OUT} = 1.0V$, $C_{OUT} = 47 \mu F$, $T_A = +25^\circ C$. Boldface values indicate $-40^\circ C \leq T_J \leq +125^\circ C$.						
Parameter	Symbol	Min.	Typ.	Max.	Units	Test Conditions
V_{IN} Supply						
Input Range	PV_{IN}	2.4	—	5.5	V	
Undervoltage Lockout Threshold	UVLO	2.15	2.225	2.35	V	SV_{IN} rising
Undervoltage Lockout Hysteresis	UVLO_H	—	153	—	V	SV_{IN} falling (Note 3)
Operating Supply Current	I_{IN0}	—	60	100	μA	$V_{FB} = 1.2V$, non-switching
Shutdown Current	I_{SHDN}	—	1.5	10	μA	$V_{EN} = 0V$, $PV_{IN} = SV_{IN} = 5.5V$, $-40^\circ C \leq T_J \leq +105^\circ C$
				20	μA	$V_{EN} = 0V$, $PV_{IN} = SV_{IN} = 5.5V$, $-40^\circ C \leq T_J \leq +125^\circ C$
Output Voltage						
Output Accuracy	V_{OUT_ACC}	0.5910	0.6	0.6090	V	$V_{SEL2} = 0$; $V_{SEL1} = 0$
		0.7880	0.8	0.8120	V	$V_{SEL2} = 0$; $V_{SEL1} = Z$
		0.8865	0.9	0.9135	V	$V_{SEL2} = 0$; $V_{SEL1} = 1$
		0.9850	1	1.0150	V	$V_{SEL2} = Z$; $V_{SEL1} = 0$
		1.1820	1.2	1.2180	V	$V_{SEL2} = Z$; $V_{SEL1} = Z$
		1.4775	1.5	1.5225	V	$V_{SEL2} = Z$; $V_{SEL1} = 1$
		1.7730	1.8	1.8270	V	$V_{SEL2} = 1$; $V_{SEL1} = 0$
		2.4625	2.5	2.5375	V	$V_{SEL2} = 1$; $V_{SEL1} = Z$
		3.2505	3.3	3.3495	V	$V_{SEL2} = 1$; $V_{SEL1} = 1$
Line Regulation		—	0.03	—	%	$V_{OUT} = 1.0V$, $V_{IN} = 2.5V$ to $5.5V$, $I_{OUT} = 300 mA$ (Note 3)
Load Regulation		—	0.1	—	%	$V_{OUT} = 1.0V$, $I_{OUT} = 0A$ to $3A$ (Note 3)
Enable Control						
EN Logic Level High	V_{EN_H}	1.2	—	—	V	V_{EN} rising, regulator enabled
EN Logic Level Low	V_{EN_L}	—	—	0.4	V	V_{EN} falling, regulator shutdown
EN Low Input Current	I_{EN_L}	—	0.01	500	nA	$V_{EN} = 0V$
EN High Input Current	I_{EN_H}	—	0.01	500	nA	$V_{EN} = 5.5V$
Enable Lockout Delay		0.15	0.25	0.4	ms	
V_{SEL} Logic Level Control						
$V_{SEL1,2}$ Logic Level High	V_{SEL_H}	1.2	—	—	V	$V_{SEL1,2}$ rising, regulator enabled
$V_{SEL1,2}$ Logic Level Low	V_{SEL_L}	—	—	0.4	V	$V_{SEL1,2}$ falling, regulator shutdown
$V_{SEL1,2}$ Logic Level Open	V_{SEL_O}	—	0.8	—	V	$V_{SEL1,2}$ falling, regulator shutdown (Note 3)
$V_{SEL1,2}$ Low Input Current	I_{VSEL_L}	-1	0.01	1	μA	$V_{SEL1,2} = 0V$
$V_{SEL1,2}$ High Input Current	I_{VSEL_H}	-1	0.01	1	μA	$V_{SEL1,2} = 5.5V$

Note 1: Specification for packaged product only.

2: Tested in open loop. The closed-loop current limit is affected by the inductance value.

3: Not production tested, data from bench characterization only

ELECTRICAL CHARACTERISTICS ⁽¹⁾ (CONTINUED)

Electrical Specifications: Unless otherwise specified, $PV_{IN} = 5V$; $V_{OUT} = 1.0V$, $C_{OUT} = 47 \mu F$, $T_A = +25^\circ C$.
Boldface values indicate $-40^\circ C \leq T_J \leq +125^\circ C$.

Parameter	Symbol	Min.	Typ.	Max.	Units	Test Conditions
T_{ON} Control/Switching Frequency						
Switching ON Time	T _{ON}	—	180	—	ns	V _{IN} = 5V, V _{OUT} = 1V
Switching Frequency	FREQ	—	1.2	—	MHz	V _{OUT} = 1.0V, I _{OUT} = 3A (Note 3)
		—	1.1	—		V _{OUT} = 3.3V, I _{OUT} = 3A
Maximum Duty Cycle	DCMAX	—	—	100	%	Note 3
Short Circuit Protection						
High-Side MOSFET Forward Current Limit	I _{LIM_HS}	4	5	6.5	A	Note 2
Low-Side MOSFET Forward Current Limit	I _{LIM_LS}	—	4.2	—	A	Note 2, Note 3
Low-Side MOSFET Negative Current Limit	I _{LIM_NEG}	-2	-3	-4	A	Note 2
N-Channel Zero-Crossing Threshold	I _{ZC_TH}	—	0.9	—	A	Note 3
Current Limit Pulses Before Hiccup	HICCUP	—	8	—	Cycles	Note 3
Hiccup Period Before Restart	—	—	1	—	ms	Note 3
Internal MOSFETS						
High-Side On Resistance	R _{DS-ON-HS}	—	30	60	mΩ	I _{SW} = 1A
Low-Side On Resistance	R _{DS-ON-LS}	—	16	40	mΩ	I _{SW} = -1A
Output Discharge Resistance	R _{DS-ON-DSC}	—	10	50	Ω	V _{EN} = 0V, V _{SW} = 5.5V, from V _{OUT} to P _{GND}
SW Leakage Current	I _{LEAK_SW}	—	1	10	μA	P _{VIN} = 5.5V, V _{SW} = 0V, V _{EN} = 0V, current flowing out of SW pin
Power-Good (PG)						
Power Good Threshold	PG_TH	87	91	95	%V _{OUT}	V _{OUT} rising (good)
Power Good Hysteresis	PG_HYS	—	4	—	%V _{OUT}	V _{OUT} falling (Note 3)
Power Good Blanking Time	PG_BLANK	—	65	—	μs	Note 3
PG Output Leakage Current	PG_LEAK	—	30	300	nA	V _{OUT} = V _{OUT} (NOM), V _{PG} = 5.5V
Power Good Sink Low Voltage	PG_SINKV	—	—	200	mV	V _{OUT} = 0V; I _{PG} = 10 mA
Thermal Shutdown						
Thermal Shutdown	T _{SHDN}	—	165	—	°C	T _J rising (Note 3)
Thermal Shutdown Hysteresis	T _{SHDN_HYST}	—	22	—	°C	T _J falling (Note 3)
Thermal Latch-Off Soft Start Cycles	TH_LATCH	—	4	—	—	Note 3

Note 1: Specification for packaged product only.

2: Tested in open loop. The closed-loop current limit is affected by the inductance value.

3: Not production tested, data from bench characterization only

MIC33M350

TEMPERATURE SPECIFICATIONS

Electrical Specifications: unless otherwise specified, $S_{VIN} = P_{VIN} = 5V$; $V_{OUT} = 1.0V$, $C_{OUT} = 47 \mu F$, $T_A = +25^\circ C$.
Boldface values indicate $-40^\circ C \leq T_J \leq +125^\circ C$.

Parameters	Sym.	Min.	Typ.	Max.	Units	Conditions
Temperature Ranges						
Junction Temperature	T_J	-40	—	125	$^\circ C$	
Storage Temperature Range	T_A	-65	—	150	$^\circ C$	
Package Thermal Resistances						
Thermal Resistance, 24-Lead, 3 mm x 4.5 mm QFN	θ_{JA}	—	+36	—	$^\circ C/W$	

2.0 TYPICAL CHARACTERISTIC CURVES

Note: The graphs and tables provided following this note are a statistical summary based on a limited number of samples and are provided for informational purposes only. The performance characteristics listed herein are not tested or guaranteed. In some graphs or tables, the data presented may be outside the specified operating range (e.g., outside specified power supply range) and therefore outside the warranted range.

Note: Unless otherwise indicated, $PV_{IN} = 5V$, $V_{OUT} = 1V$, $C_{OUT} = 47 \mu F$, $T_A = +25^\circ C$.

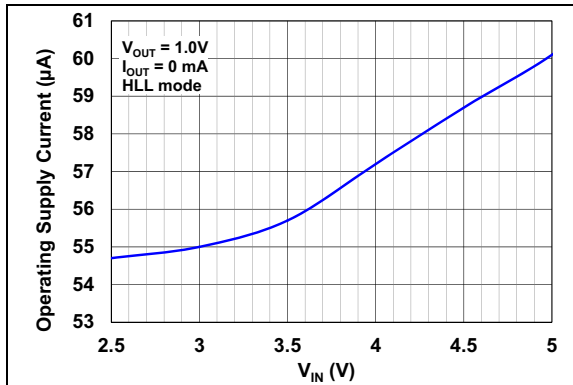

FIGURE 2-1: Operating Supply Current vs. Input Voltage, Switching.

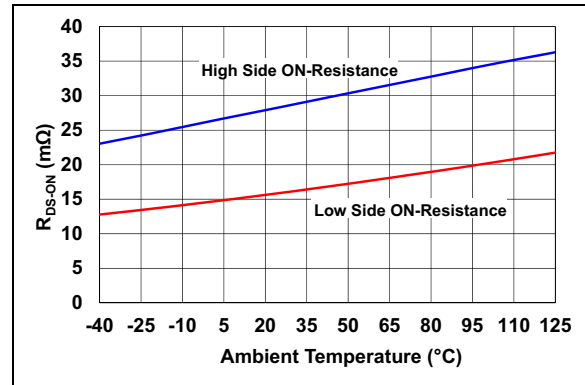

FIGURE 2-4: $R_{DS(on)}$ vs. Temperature.

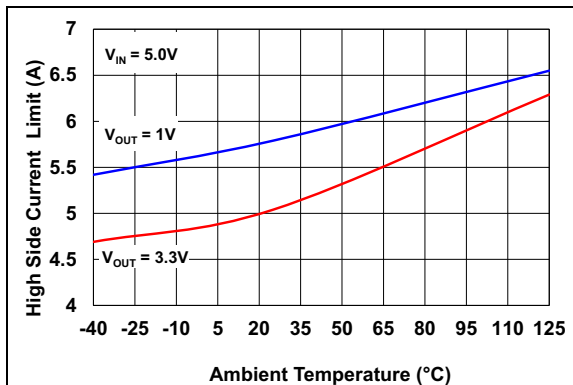

FIGURE 2-2: High-Side Current Limits vs. Temperature.

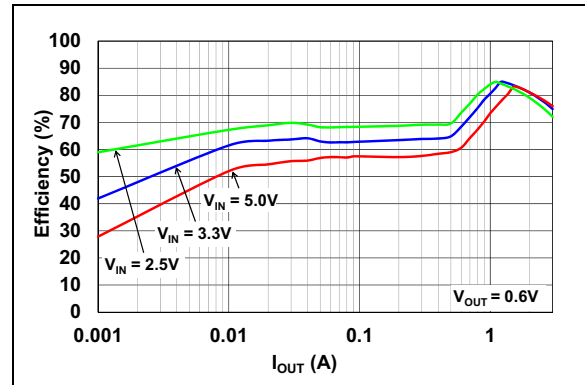

FIGURE 2-5: Efficiency vs. Load Current ($V_{OUT} = 0.6V$).

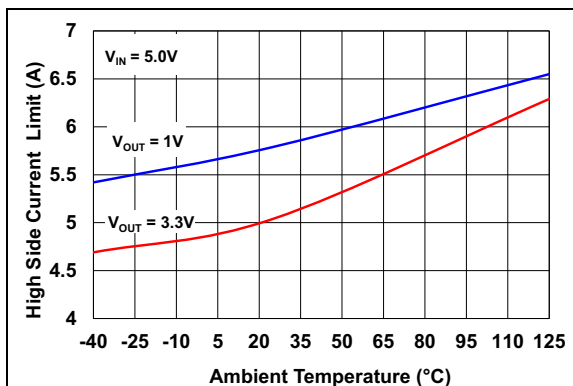

FIGURE 2-3: Operating Supply Current vs. Temperature, Switching.

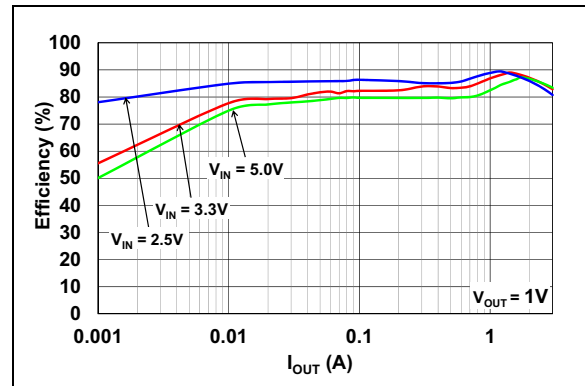

FIGURE 2-6: Efficiency vs. Load Current ($V_{OUT} = 1V$).

MIC33M350

Note: Unless otherwise indicated, $PV_{IN} = 5V$, $V_{OUT} = 1V$, $C_{OUT} = 47 \mu F$, $T_A = +25^\circ C$.

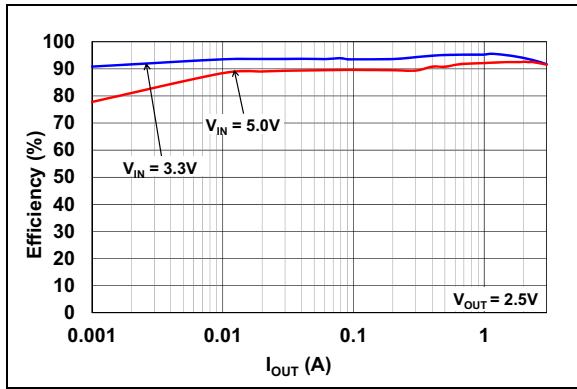

FIGURE 2-7: Efficiency vs. Load Current ($V_{OUT} = 2.5V$).

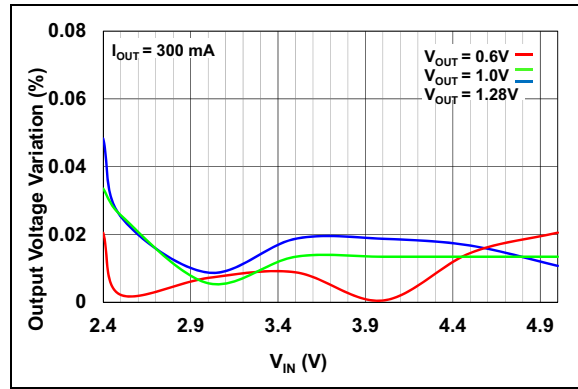

FIGURE 2-10: Output Voltage Variation vs. Input Voltage.

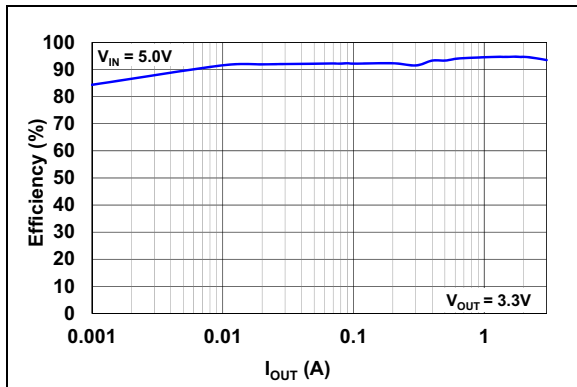

FIGURE 2-8: Efficiency vs. Load Current ($V_{OUT} = 3.3V$).

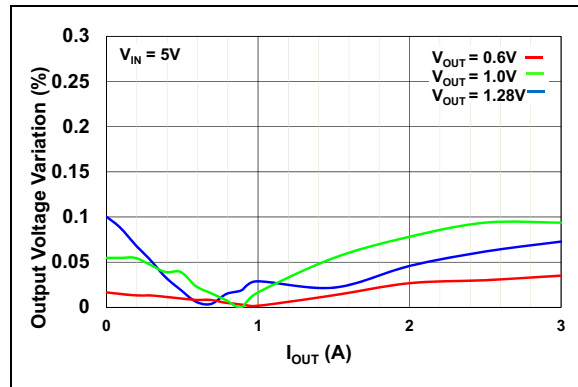

FIGURE 2-11: V_{OUT} Voltage vs. I_{OUT} .

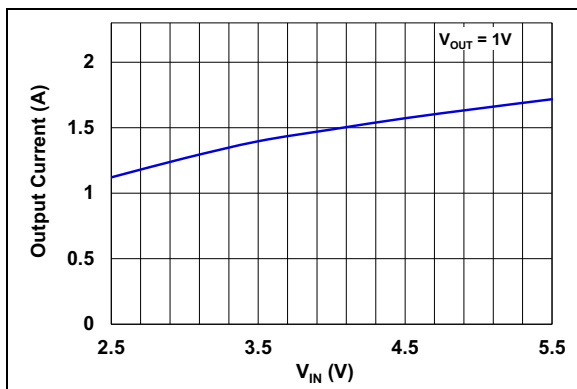

FIGURE 2-9: DCM/FPWM I_{OUT} Threshold vs. V_{IN} .

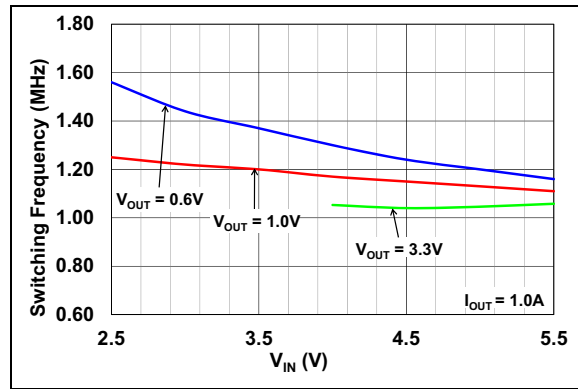

FIGURE 2-12: Switching Frequency vs. Input Voltage.

Note: Unless otherwise indicated, $PV_{IN} = 5V$, $V_{OUT} = 1V$, $C_{OUT} = 47 \mu F$, $T_A = +25^\circ C$

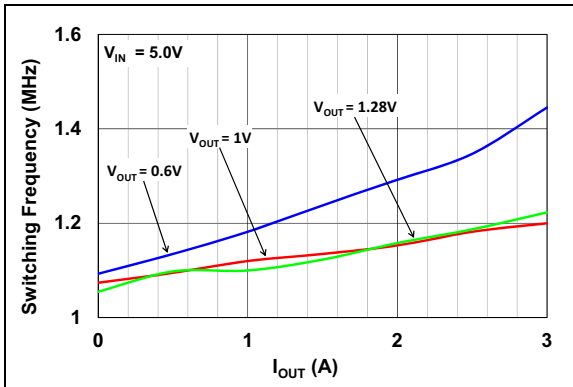

FIGURE 2-13: Switching Frequency vs. Output Current.

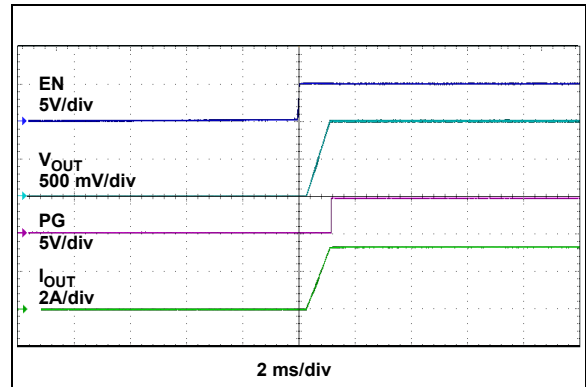

FIGURE 2-16: EN Turn-On, $R_{LOAD} = 0.3\Omega$.

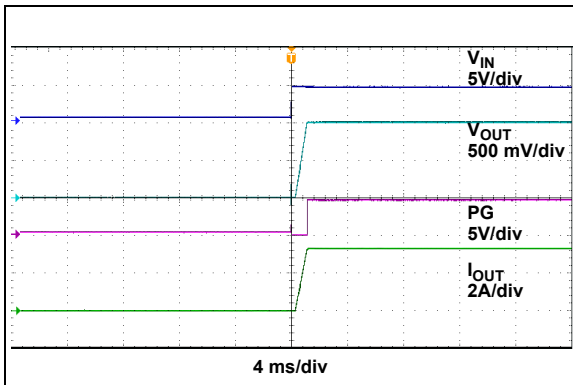

FIGURE 2-14: V_{IN} Turn-On ($EN = PV_{IN}$).

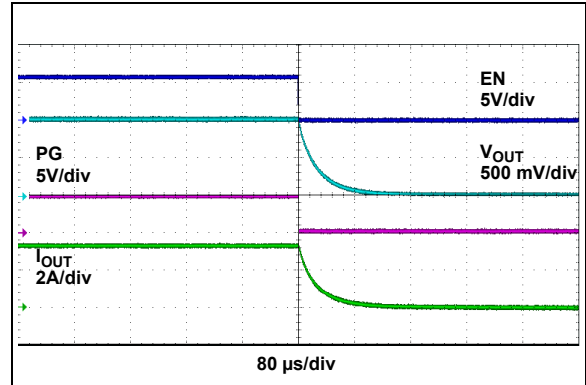

FIGURE 2-17: EN Turn-Off, $R_{LOAD} = 0.3\Omega$.

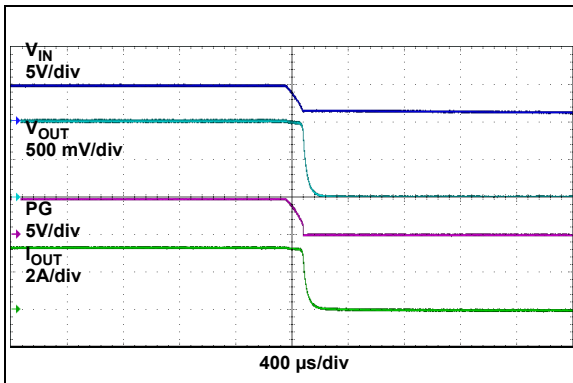

FIGURE 2-15: V_{IN} Turn-Off ($EN = PV_{IN}$), $R_{LOAD} = 0.3\Omega$.

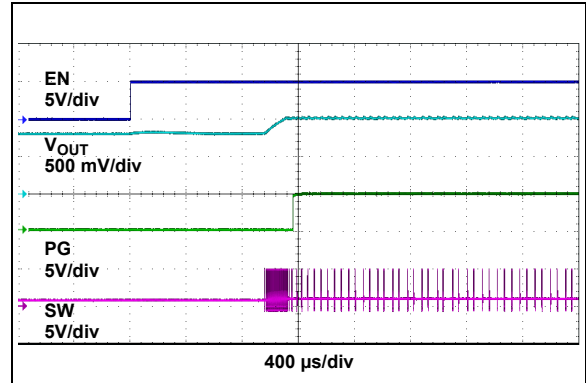

FIGURE 2-18: EN Turn-On Into Pre-Biased Output ($V_{pre-bias} = 0.8V$).

MIC33M350

Note: Unless otherwise indicated, $PV_{IN} = 5V$, $V_{OUT} = 1V$, $C_{OUT} = 47 \mu F$, $T_A = +25^\circ C$.

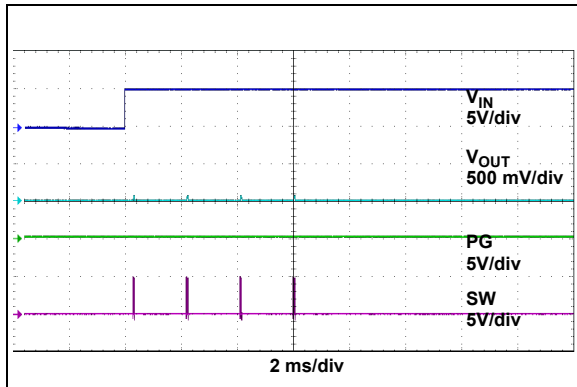

FIGURE 2-19: Power-Up Into Short Circuit.

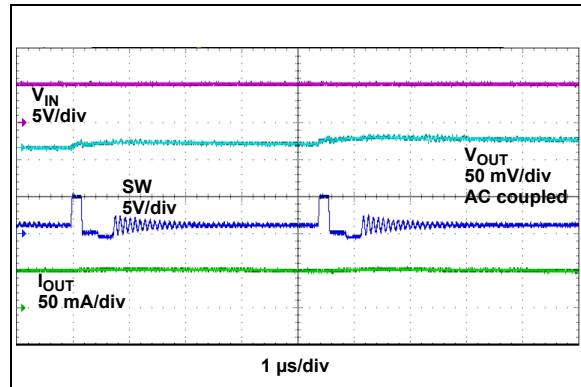

FIGURE 2-22: Switching Waveforms - $I_{OUT} = 50 \text{ mA}$, HLL Mode.

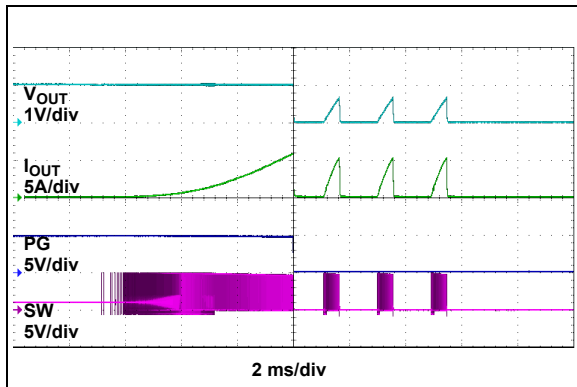

FIGURE 2-20: Output Current Limit Threshold.

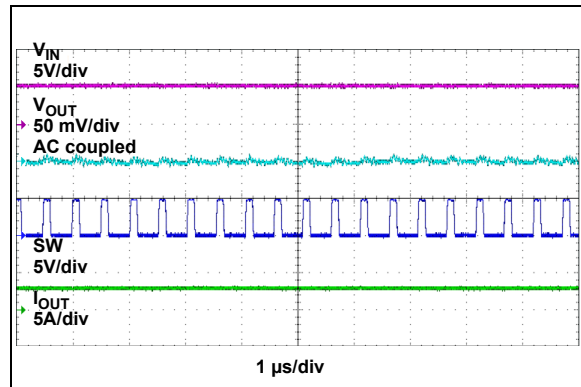

FIGURE 2-23: Switching Waveforms - $I_{OUT} = 3A$.

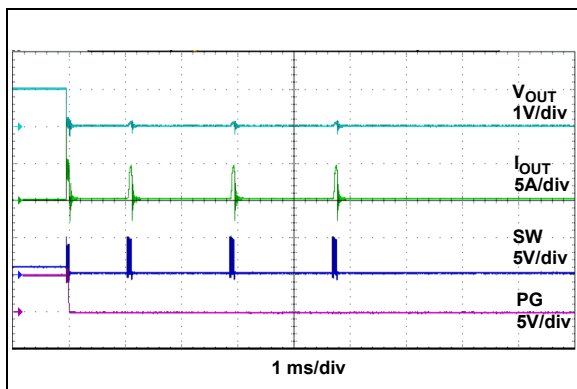

FIGURE 2-21: Hiccup Mode Short Circuit Current Limit Response.

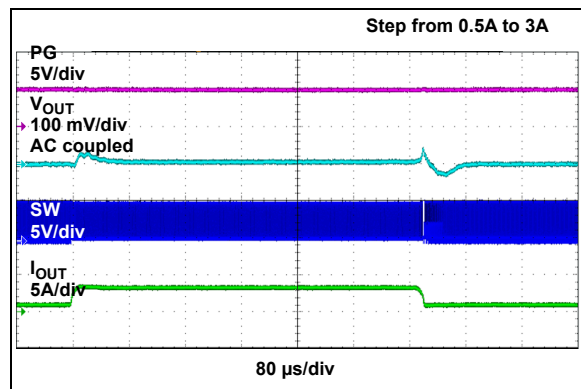

FIGURE 2-24: Load Transient Response.

Note: Unless otherwise indicated, $PV_{IN} = 5V$, $V_{OUT} = 1V$, $C_{OUT} = 47 \mu F$, $T_A = +25^\circ C$.

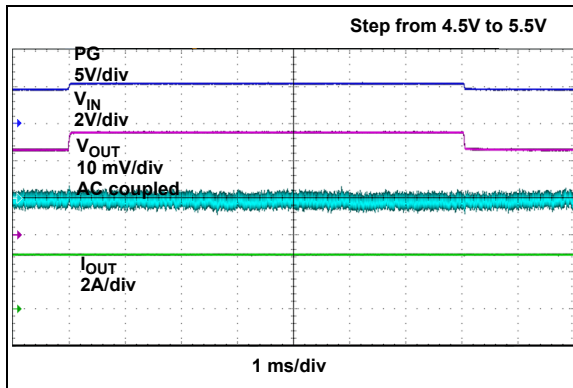

FIGURE 2-25: Line Transient Response.

MIC33M350

NOTES:

3.0 PIN DESCRIPTION

The descriptions of the pins are listed in [Table 3-1](#).

TABLE 3-1: PIN FUNCTION TABLE

MIC33M350	Symbol	Pin Function
1, 2, 3, 10, 11	P _{GND}	Power Ground Pin: P _{GND} is the ground path for the MIC33M350 buck converter power stage.
4, 5, 6, 7, 8, 9	SW	Switch Node Pin
17	PV _{IN}	Power Supply Voltage Pin
18	SV _{IN}	Analog Voltage Input Pin. The power to the internal reference and control sections of the MIC33M350 device. A 1.0 μF ceramic capacitor from SV _{IN} to GND must be used. Internally connected to PV _{IN} through a 10Ω resistor.
19	V _{SEL2}	Output Voltage Selection Control Pin 2 (Input): The Logic state of the V _{SEL1} and V _{SEL2} selects the register that sets the output voltage. This input has three Digital states: High, Low and Floating.
20	V _{SEL1}	Output Voltage Selection Control Pin 1 (Input): The Logic state of the V _{SEL1} and V _{SEL2} selects the register that sets the output voltage. This input has three Digital states: High, Low and Floating.
21	EN	Enable Pin (Input): Logic high enables operation of the regulator. The EN pin should not be left open.
22	PG	Power Good Pin (Output): This is an open-drain output that indicates when the output voltage is lower than the 91% limit.
23	V _{OUT}	Output Voltage Sense Pin (Input): This pin is used to remote sense the output voltage. Connect V _{OUT} as close to the output capacitor as possible to sense output voltage. Also provides the path to discharge the output through an internal 10Ω resistor when disabled.
12, 13, 14, 15, 16	OUT	Power Output Side Connection Pins
24	A _{GND}	Analog Ground: Internal signal ground for all low-power circuits
25	EP1_P _{GND}	Exposed Thermal Pad Pin: Internally connected to P _{GND}
26	EP2_P _{GND}	Exposed Thermal Pad Pin: Internally connected to P _{GND}
27	EP_SW	Exposed Thermal Pad Pin: Internally connected to SW Node
28	EP_OUT	Exposed Thermal Pad Pin: Internally connected to Output side

MIC33M350

3.1 Power Ground Pin (P_{GND})

P_{GND} is the ground path for the MIC33M350 buck converter power stage. The P_{GND} pin connects to the sources of the low-side N-Channel MOSFETs, the negative terminals of input capacitors and the negative terminals of output capacitors. The loop for the Power Ground should be as small as possible and separate from the Analog Ground (A_{GND}) loop.

3.2 Switch Node Pin (SW)

The SW pin connects directly to the switch node. The Switching Node output pin is connected to the internal MOSFETs and inductor. Due to the high-speed switching on this pin, the SW pin should be routed away from sensitive nodes. The SW pin also senses the current by monitoring the voltage across the low-side MOSFET during off-time.

3.3 Input Voltage Pin (PV_{IN})

This is an input supply to the source of the internal high-side P-channel MOSFET. The PV_{IN} operating voltage range is from 2.4V to 5.5V. An input capacitor between PV_{IN} and the Power Ground (P_{GND}) pin is required and placed as close as possible to the IC.

3.4 Analog Voltage Input Pin (SV_{IN})

The power to the internal reference and control sections of the MIC33M350. A 1.0 μ F ceramic capacitor from SV_{IN} to ground must be used. Internally connected to PV_{IN} through a 10 Ω resistor.

3.5 Output Voltage Selection Control Pin 2 (V_{SEL2})

The Logic state of the V_{SEL1} and V_{SEL2} selects the output voltage. This input has three Digital states: High, Low and Floating. See [Table 4-1](#).

3.6 Output Voltage Selection Control Pin 1 (V_{SEL1})

The Logic state of the V_{SEL1} and V_{SEL2} selects the output voltage. This input has three Digital states: High, Low and Floating. See [Table 4-1](#).

3.7 Enable Pin (EN)

Logic high enables operation of the regulator. Logic low shuts down the device. In the OFF state, the supply current to the device is greatly reduced (typically 1.5 μ A). The EN pin should not be left open.

3.8 Power Good Pin (PG)

This is an open-drain output that indicates when the output voltage is higher than the 91% limit. There is a 4% hysteresis, therefore, PG will return to low when the falling output voltage falls below 87% of the target regulation voltage.

3.9 Output Voltage Sense Pin (V_{OUT})

This pin is used to remotely sense the output voltage. Connect it to V_{OUT} as close to the output capacitor as possible to sense output voltage. This pin also provides the path to discharge the output through an internal 10 Ω resistor when it is disabled.

3.10 Analog Ground Pin (A_{GND})

This is an internal signal ground for all low-power circuits. Connect it to ground plane. For the best load regulation, the connection path from A_{GND} to the output capacitor ground terminal should be free from parasitic voltage drops.

3.11 EP1_ P_{GND} , EP2_ P_{GND}

These pins electrically connected to the P_{GND} pins. They must be connected with thermal vias to the ground plane to ensure adequate heat sinking.

3.12 EP_SW Exposed Pad (SW)

This pin is electrically connected to the SW node.

3.13 OUT Exposed Pad (OUT)

This pin is electrically connected to the OUT pins. It must be externally connected to the output power connection.

4.0 DETAILED DESCRIPTION

4.1 Device Overview

The MIC33M350 device is a high-efficiency, 3A current, synchronous buck regulator power module with integrated inductor. The COT control architecture with automatic HyperLight Load mode provides very high efficiency at light loads and ultra-fast transient response.

The MIC33M350 output voltage is set by two V_{SEL} three-state logic pins that can set the output voltage to nine different values (see Table 4-1).

The 2.4V to 5.5V input voltage operating range makes the device ideal for single cell Li-ion battery-powered applications. The 100% duty cycle capability provides Low Dropout operation, extending battery life in portable systems. The automatic HyperLight Load mode provides very high efficiency at light loads.

These devices focus on high output voltage accuracy. Total output error is less than 1.5% over line, load and temperature.

MIC33M350 focuses on high output voltage accuracy.

The MIC33M350 buck regulator uses an adaptive Constant On-Time control method. The adaptive on-time control scheme is employed to obtain a nearly constant switching frequency and to simplify the control compensation. Overcurrent protection is implemented without the use of an external sense resistor. The MIC33M350 device includes an internal soft start function which reduces the power supply input surge current at start-up by controlling the output voltage rise time.

4.2 HyperLight Load[®] Mode (HLL)

HLL is a power-saving mode. In HLL, the switching frequency is not constant over the operation current range. At light loads, the minimum duty cycle is limited, which causes the switching frequency to decrease at light loads, this reduces switching and drive losses, and increases efficiency.

4.3 Enable (EN)

When the EN pin is pulled low, the IC is in a Shutdown state, with all internal circuits disabled and with the Power Good output low. During shutdown, the MIC33M350 part typically consumes 1.5 μ A. When the EN pin is pulled high, the start-up sequence is initiated.

4.4 Power Good (PG)

The Power Good output is generally used for power sequencing, where the PG output is tied to the Enable output of another regulator. This technique avoids all the regulators powering up at the same time, which causes large inrush current.

PG is an open-drain output that indicates that the output is above 87% of its voltage set value. During start-up, when the output voltage is rising, the Power Good output goes high when the output voltage reaches 91% of its set value. The Power Good threshold has 4% hysteresis, so the Power Good output stays high until the output voltage falls below 87% of the set value. A built-in 65 μ s blanking time is incorporated to prevent nuisance tripping.

A pull-up resistor can be connected to V_{IN} , V_{OUT} , or an external source that is less than or equal to V_{IN} . The PG pin can be connected to another regulator's enable pin for sequencing of the outputs. The PG output is deasserted as soon as the Enable pin is pulled low or an input undervoltage condition, or any other Fault is detected.

4.5 Resistive Discharge (Soft Discharge)

To ensure a known output condition when the output is turned off, then back on again (i.e. in a brown output condition), the output is actively discharged to ground by means of an internal 10 Ω resistor if the output is disabled.

MIC33M350

4.6 Output Voltage Setting

The MIC33M350 device has two pins, V_{SEL1} and V_{SEL2} , which are used for choosing between nine predefined voltage settings: 0.6V, 0.8V, 0.9V, 1.0V, 1.2V, 1.5V, 1.8V, 2.5V, 3.3V. These pins can be tied to V_{IN} , GND or left floating. The relationship between V_{SEL1}/V_{SEL2} and the output voltage is shown in Table 4-1.

TABLE 4-1: OUTPUT VOLTAGE SETTINGS

V_{SEL2}	V_{SEL1}	V_{OUT}
GND	GND	0.6V
GND	OPEN	0.8V
GND	V_{IN}	0.9V
OPEN	GND	1.0V
OPEN	OPEN	1.2V
OPEN	V_{IN}	1.5V
V_{IN}	GND	1.8V
V_{IN}	OPEN	2.5V
V_{IN}	V_{IN}	3.3V

V_{OUT} should be connected exactly to the desired Point-of-Load (POL) regulation, avoiding parasitic resistive drops. It is possible to fine-tune the desired output voltage by adding a series resistor on the V_{OUT} pin. This allows slightly higher output value programming, but should not exceed 5% deviation from the V_{SEL} selected value.

EQUATION 4-1:

$$R_{VOUT} = 8.2 \text{ k}\Omega \times TRIM$$

Where:

$$R_{VOUT} = V_{OUT} \text{ series resistance needed for a } TRIM\% \text{ output voltage increase}$$

4.7 Converter Stability/Output Capacitor

The MIC33M350 device utilizes an internal compensation network and is designed to provide stable operation with output capacitors, from 47 μF to 1000 μF . This greatly simplifies the design, where you can add supplementary output capacitance without having to worry about stability.

4.8 Soft Start

Excess bulk capacitance on the output can cause excessive input inrush current. The MIC33M350 soft start feature forces the output voltage to rise gradually, keeping the inrush current at reasonable levels. This is particularly important in battery-powered applications. When the Enable pin goes high, the output voltage starts to rise. Once the soft start period has finished, the Power Good comparator is enabled and the Power Good output goes high.

The output voltage soft start time is determined by the soft start equation below. The Soft Start Time, t_{SS} can be calculated by Equation 4-2.

EQUATION 4-2:

$$t_{SS} = V_{OUT} \times t_{RAMP}$$
$$t_{SS} = 1.0V \times (800 \mu\text{s})/V$$
$$t_{SS} = 800 \mu\text{s} = 0.8 \text{ ms}$$

Where:

$$V_{OUT} = 1.0V$$
$$t_{RAMP} = 800 \mu\text{s}/V$$

4.9 Dropout Operation

As the input voltage approaches the output voltage, the minimum on-time limits the maximum duty cycle. To achieve 100% duty cycle, the high-side switch is latched when the duty cycle reaches around 92% and stays latched until the output voltage falls 4% below its regulated value. In dropout, the output voltage is determined by the input voltage minus the voltage drop across the high-side MOSFET.

4.10 Switching Frequency

The switching frequency of the MIC33M350 is determined by the internal On-Time (T_{ON}) calculation. For an input voltage of 5V and an output voltage of 1V, the typical value of T_{ON} is 180 ns. The resulting switching frequency can be estimated by [Equation 4-3](#).

EQUATION 4-3:

$$f_{SW} = V_{OUT} / (V_{IN} \times T_{ON})$$

[Equation 4-3](#) is only valid in continuous conduction mode and for a lossless converter. In practice, losses cause an increase of the switching frequency compared to the ideal case. As the load current increases, losses increase too and so does the switching frequency.

The on-time calculation is adaptive, in that the T_{ON} value is modulated based on the input voltage and on the target output voltage to stabilize the switching frequency against their variations. Losses are not accounted for.

V_{IN} (V)	V_{OUT} (V)	T_{ON}
5	0.6	110
	1	180
	1.8	340
	2.5	490
	3.3	610
3.3	1	270

4.11 Undervoltage Protection (UVLO)

Undervoltage protection ensures that the IC has enough voltage to bias the internal circuitry properly and provide sufficient gate drive for the power MOSFETs. When the input voltage starts to rise, both power MOSFETs are off and the power good output is pulled low. The IC starts at approximately 2.225V and has a nominal 153 mV of hysteresis to prevent chattering between the UVLO high and low states.

4.12 Overtemperature Fault

The MIC33M350 monitors the die junction temperature to keep the IC operating properly. If the IC junction temperature exceeds +165°C, both power MOSFETs are immediately turned off. The IC is allowed to restart when the die temperature falls below +143°C.

During recovery from a thermal shutdown event, if the regulator hits another thermal shutdown event or a current limit event causing hiccup before Power Good can be achieved, the controller resets again. If this happens more than four times in a row, then the part enters the Latch-Off state, which turns off both MOSFETs permanently. The MIC33M350 part does not restart again unless the input power is cycled. This Latch-Off feature eliminates the thermal stress on the MIC33M350 during a persistent Fault event.

4.13 Safe Start-up Into a Pre-Biased Output

The MIC33M350 is designed for safe start-up into a pre-biased output in forced PWM. This feature prevents high negative inductor current flow in a pre-bias condition, which can damage the IC. This is achieved by not allowing forced PWM until the control loop commands eight switching cycles. After eight cycles, the low-side negative current limit is switched from 0A to -3A. The cycle counter is reset to zero if the enable pin is pulled low, or an input undervoltage condition or any other Fault is detected.

4.14 Current Limiting

The MIC33M350 regulator uses both high-side and low-side current sense for current limiting. When the high-side current sense threshold is reached, the high-side MOSFET is turned off and the low-side MOSFET is turned on. The low-side MOSFET stays on until the current falls to 80% of the high-side current threshold value, then the high side can be turned on again. If the overload condition lasts for more than four cycles, the MIC33M350 enters hiccup current limiting and both MOSFETs are turned off. There is a 1 ms cool-off period before the MOSFETs are allowed to be turned on. If the regulator has another hiccup event before it reaches the Power Good threshold on restart, turn both MOSFETs off again and wait for 1 ms. If this happens more than three times in a row, then the part enters the Latch-Off state, which turns off both MOSFETs permanently, unless the part is reset by cycling the input power.

4.15 Thermal Considerations

Although the MIC33M350 is capable of delivering up to 3A under load, the package thermal resistance and the device internal power dissipation may dictate some limitations to the continuous output current.

If operated above the rated junction temperature, electrical parameters may drift beyond characterized specifications. The MIC33M350 is protected under all circumstances by thermal shutdown.

MIC33M350

NOTES:

5.0 APPLICATION INFORMATION

5.1 Output Voltage Sensing

To achieve accurate output voltage regulation, the V_{OUT} pin (internal feedback divider top terminal) should be Kelvin-connected as close as possible to the point of regulation top terminal. Since both the internal reference and the internal feedback divider's bottom terminal refer to A_{GND} , it is important to minimize voltage drops between the A_{GND} and the point of regulation return terminal (typically the ground terminal of the output capacitor which is closest to the load).

5.2 Output Capacitor Selection

The type of the output capacitor is usually determined by its Equivalent Series Resistance (ESR). Voltage and RMS current capability are two other important factors for selecting the output capacitor. Recommended capacitor types are ceramic, low-ESR aluminum electrolytic, OS-CON, and POSCAP. The output capacitor's ESR is usually the main cause of the output ripple. The output capacitor ESR also affects the control loop from a stability point of view. The maximum value of ESR is calculated using [Equation 5-1](#).

EQUATION 5-1:

$$ESR_{C_{OUT}} \leq \frac{\Delta V_{OUT(PP)}}{\Delta I_{L(PP)}}$$

Where:

$V_{OUT(PP)}$	Peak-to-peak output voltage ripple
$I_{L(PP)}$	Peak-to-peak inductor current ripple

The peak-to-peak inductor current ripple can be calculated with the formula in [Equation 5-2](#).

EQUATION 5-2:

$$\Delta I_{L(PP)} = \frac{V_{OUT} \times (V_{IN(MAX)} - V_{OUT})}{V_{IN(MAX)} \times f_{SW} \times L}$$

Where:

$L = 0.47 \mu\text{H}$

The total output ripple is a combination of the ESR and output capacitance. The total ripple is calculated in [Equation 5-3](#).

EQUATION 5-3:

$$\Delta V_{OUT(PP)} = \sqrt{\left(\frac{\Delta I_{L(PP)}}{C_{OUT} \times f_{SW} \times 8}\right)^2 + \left(\Delta I_{L(PP)} \times ESR_{C_{OUT}}\right)^2}$$

Where:

C_{OUT}	Output Capacitance Value
f_{SW}	Switching Frequency

The output capacitor RMS current is calculated in [Equation 5-4](#).

EQUATION 5-4:

$$I_{C_{OUT}(RMS)} = \frac{\Delta I_{L(PP)}}{\sqrt{12}}$$

The power dissipated in the output capacitor is:

EQUATION 5-5:

$$P_{DISS(C_{OUT})} = I_{C_{OUT}(RMS)}^2 \times ESR_{C_{OUT}}$$

5.3 Input Capacitor Selection

The input capacitor for the power stage input V_{IN} should be selected for ripple current rating and voltage rating. Tantalum input capacitors can fail when subjected to high inrush currents, caused by turning on the input supply. A tantalum input capacitor's voltage rating should be at least two times the maximum input voltage, to maximize reliability. Aluminum electrolytic, OS-CON, and multilayer polymer film capacitors can handle the higher inrush currents without voltage derating. The input voltage ripple depends on the input capacitor's ESR. The peak input current is equal to the peak inductor current, as shown in [Equation 5-6](#).

EQUATION 5-6:

$$\Delta V_{IN} = I_{L(PK)} \times C_{ESR}$$

The input capacitor must be rated for the input current ripple. The RMS value of input capacitor current is determined at the maximum output current. Assuming the peak-to-peak inductor current ripple is low:

EQUATION 5-7:

$$I_{CIN(RMS)} \approx I_{OUT(MAX)} \times \sqrt{D \times (1-D)}$$

The power dissipated in the input capacitor is calculated in [Equation 5-8](#).

EQUATION 5-8:

$$P_{DISS(CIN)} = I_{CIN(RMS)}^2 \times C_{ESR}$$

MIC33M350

NOTES:

6.0 PACKAGE MARKING INFORMATION

MIC33M350

24-Lead QFN, 3.0 mm x 4.5 mm x 1.8 mm

Example

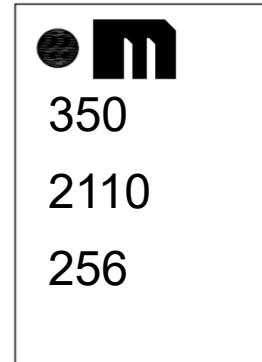

Legend:	XX...X	Customer-specific information
	Y	Year code (last digit of calendar year)
	YY	Year code (last 2 digits of calendar year)
	WW	Week code (week of January 1 is week '01')
	NNN	Alphanumeric traceability code
	(e3)	Pb-free JEDEC designator for Matte Tin (Sn)
	*	This package is Pb-free. The Pb-free JEDEC designator (e3) can be found on the outer packaging for this package.

Note: In the event the full Microchip part number cannot be marked on one line, it will be carried over to the next line, thus limiting the number of available characters for customer-specific information.

24-Lead Plastic Quad Flat, No Lead Package (N6A) - 3x4.5 mm Body [QFN]

Note: For the most current package drawings, please see the Microchip Packaging Specification located at <http://www.microchip.com/packaging>

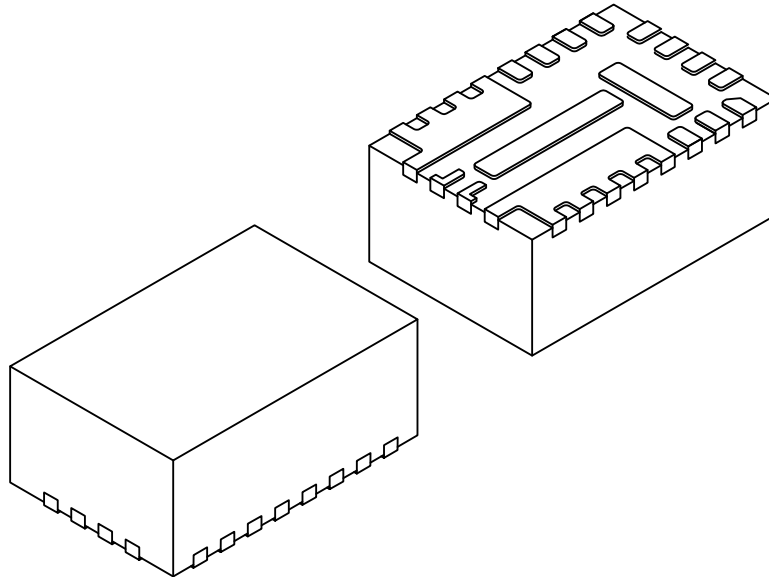

		Units	MILLIMETERS		
Dimension Limits			MIN	NOM	MAX
Number of Terminals	N		24		
Pitch	e		0.50 BSC		
Overall Height	A	1.80	1.85	1.90	
Standoff	A1	0.00	0.02	0.05	
Terminal Thickness	A3	0.203 REF			
Overall Length	D	3.00 BSC			
Exposed Pad Length	D2	0.338	0.388	0.438	
Exposed Pad Length	D3	1.344	1.394	1.444	
Overall Width	E	4.50 BSC			
Exposed Pad Width	E2	2.35	2.40	2.45	
Exposed Pad Width	E3	0.326	0.376	0.426	
Terminal Width	b	0.20	0.25	0.30	
Terminal Width	b2	0.08	0.13	0.18	
Terminal Length	L	0.35	0.40	0.45	
Terminal Length	L2	0.20	0.25	0.30	
Terminal to Exposed Pad	K1	0.20	-	-	
Terminal to Exposed Pad	K2	0.20	-	-	

Notes:

1. Pin 1 visual index feature may vary, but must be located within the hatched area.
2. Package is saw singulated
3. Dimensioning and tolerancing per ASME Y14.5M

BSC: Basic Dimension. Theoretically exact value shown without tolerances.

REF: Reference Dimension, usually without tolerance, for information purposes only.

Microchip Technology Drawing C04-1220A Sheet 2 of 2

MIC33M350

24-Lead Plastic Quad Flat, No Lead Package (N6A) - 3x4.5 mm Body [QFN]

Note: For the most current package drawings, please see the Microchip Packaging Specification located at <http://www.microchip.com/packaging>

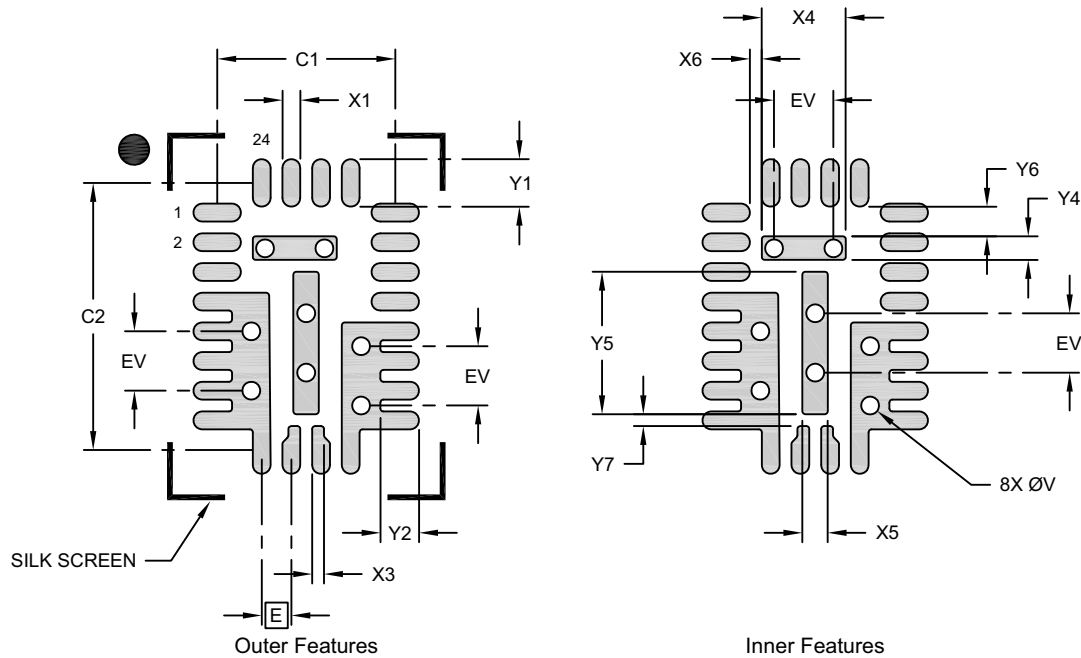

RECOMMENDED LAND PATTERN

Dimension Limits	Units	MILLIMETERS		
		MIN	NOM	MAX
Contact Pitch	E	0.50 BSC		
Contact Pad Spacing	C1			3.00
Contact Pad Spacing	C2			4.50
Contact Pad Width (X24)	X1		0.30	
Contact Pad Length (X24)	Y1		0.80	
Contact Pad Length (X7)	Y2		0.65	
Contact Pad Width	X3		0.20	
Exposed Pad Length	X4			1.41
Exposed Pad Width	Y4			0.40
Exposed Pad Width	X5			0.43
Exposed Pad Length	Y5			2.40
Terminal to Exposed Pad	X6	0.20		
Terminal to Exposed Pad	Y6	0.50		
Terminal to Exposed Pad	Y7	0.20		
Thermal Via Diameter	V		0.30	
Thermal Via Pitch	EV		1.00	

Notes:

1. Dimensioning and tolerancing per ASME Y14.5M
BSC: Basic Dimension. Theoretically exact value shown without tolerances.
2. For best soldering results, thermal vias, if used, should be filled or tented to avoid solder loss during reflow process

Microchip Technology Drawing C04-3220 Rev A

APPENDIX A: REVISION HISTORY

Revision B (March 2021)

The following is the list of modifications:

1. Added edits to incorporate the AEC-Q104 qualification.

Revision A (May 2020)

- Initial release of this document.

NOTES:

PRODUCT IDENTIFICATION SYSTEM

To order or obtain information, e.g., on pricing or delivery, refer to the factory or the listed sales office.

<u>PART NO.</u>	<u>X</u>	<u>XX</u>	<u>— XX</u>	<u>XXX</u>	Examples:
Device	Junction Temperature Range	Package	Tape and Reel Option ⁽¹⁾	Qualification	
Device: MIC33M350	Junction Temperature Range: Y = -40°C to +125°C (Extended)	Package: MP = QFN (Plastic Quad Flat, No Lead Package)	Tape and Reel Option: Blank = Tube TR = Tape and Reel	Qualification: Blank = Tube VAO = AEC-Q104 Automotive Qualification Vxx = AEC-Q104 Automotive Qualification; custom device, additional terms or conditions may apply.	<p>a) MIC33M350YMP-TR: Extended Temperature, 24-Lead QFN package, Tape and Reel</p> <p>b) MIC33M350YMP-VAO: Extended Temperature 24-Lead QFN package, Tape and Reel, Automotive Qualified</p> <p>c) MIC33M350YMP-TRVAO: Extended Temperature, 24-Lead QFN package, Tape and Reel, Automotive Qualified</p>
					Note 1: Tape and Reel identifier only appears in the catalog part number description. This identifier is used for ordering purposes and is not printed on the device package. Check with your Microchip Sales Office for package availability with the Tape and Reel option.

MIC33M350

NOTES:

Note the following details of the code protection feature on Microchip devices:

- Microchip products meet the specifications contained in their particular Microchip Data Sheet.
- Microchip believes that its family of products is secure when used in the intended manner and under normal conditions.
- There are dishonest and possibly illegal methods being used in attempts to breach the code protection features of the Microchip devices. We believe that these methods require using the Microchip products in a manner outside the operating specifications contained in Microchip's Data Sheets. Attempts to breach these code protection features, most likely, cannot be accomplished without violating Microchip's intellectual property rights.
- Microchip is willing to work with any customer who is concerned about the integrity of its code.
- Neither Microchip nor any other semiconductor manufacturer can guarantee the security of its code. Code protection does not mean that we are guaranteeing the product is "unbreakable." Code protection is constantly evolving. We at Microchip are committed to continuously improving the code protection features of our products. Attempts to break Microchip's code protection feature may be a violation of the Digital Millennium Copyright Act. If such acts allow unauthorized access to your software or other copyrighted work, you may have a right to sue for relief under that Act.

Information contained in this publication is provided for the sole purpose of designing with and using Microchip products. Information regarding device applications and the like is provided only for your convenience and may be superseded by updates. It is your responsibility to ensure that your application meets with your specifications.

THIS INFORMATION IS PROVIDED BY MICROCHIP "AS IS". MICROCHIP MAKES NO REPRESENTATIONS OR WARRANTIES OF ANY KIND WHETHER EXPRESS OR IMPLIED, WRITTEN OR ORAL, STATUTORY OR OTHERWISE, RELATED TO THE INFORMATION INCLUDING BUT NOT LIMITED TO ANY IMPLIED WARRANTIES OF NON-INFRINGEMENT, MERCHANTABILITY, AND FITNESS FOR A PARTICULAR PURPOSE OR WARRANTIES RELATED TO ITS CONDITION, QUALITY, OR PERFORMANCE.

IN NO EVENT WILL MICROCHIP BE LIABLE FOR ANY INDIRECT, SPECIAL, PUNITIVE, INCIDENTAL OR CONSEQUENTIAL LOSS, DAMAGE, COST OR EXPENSE OF ANY KIND WHATSOEVER RELATED TO THE INFORMATION OR ITS USE, HOWEVER CAUSED, EVEN IF MICROCHIP HAS BEEN ADVISED OF THE POSSIBILITY OR THE DAMAGES ARE FORESEEABLE. TO THE FULLEST EXTENT ALLOWED BY LAW, MICROCHIP'S TOTAL LIABILITY ON ALL CLAIMS IN ANY WAY RELATED TO THE INFORMATION OR ITS USE WILL NOT EXCEED THE AMOUNT OF FEES, IF ANY, THAT YOU HAVE PAID DIRECTLY TO MICROCHIP FOR THE INFORMATION. Use of Microchip devices in life support and/or safety applications is entirely at the buyer's risk, and the buyer agrees to defend, indemnify and hold harmless Microchip from any and all damages, claims, suits, or expenses resulting from such use. No licenses are conveyed, implicitly or otherwise, under any Microchip intellectual property rights unless otherwise stated.

Trademarks

The Microchip name and logo, the Microchip logo, Adaptec, AnyRate, AVR, AVR logo, AVR Freaks, BesTime, BitCloud, chipKIT, chipKIT logo, CryptoMemory, CryptoRF, dsPIC, FlashFlex, flexPWR, HELDO, IGL00, JukeBlox, KeeLoq, Kleer, LANCheck, LinkMD, maXStylus, maXTouch, MediaLB, megaAVR, Microsemi, Microsemi logo, MOST, MOST logo, MPLAB, OptoLyzer, PackeTime, PIC, picoPower, PICSTART, PIC32 logo, PolarFire, Prochip Designer, QTouch, SAM-BA, SenGenuity, SpyNIC, SST, SST Logo, SuperFlash, Symmetricom, SyncServer, Tachyon, TimeSource, tinyAVR, UNI/O, Vectron, and XMEGA are registered trademarks of Microchip Technology Incorporated in the U.S.A. and other countries.

AgileSwitch, APT, ClockWorks, The Embedded Control Solutions Company, EtherSynch, FlashTec, Hyper Speed Control, HyperLight Load, IntelliMOS, Libero, motorBench, mTouch, Powermite 3, Precision Edge, ProASIC, ProASIC Plus, ProASIC Plus logo, Quiet-Wire, SmartFusion, SyncWorld, Temux, TimeCesium, TimeHub, TimePictra, TimeProvider, WinPath, and ZL are registered trademarks of Microchip Technology Incorporated in the U.S.A.

Adjacent Key Suppression, AKS, Analog-for-the-Digital Age, Any Capacitor, AnyIn, AnyOut, Augmented Switching, BlueSky, BodyCom, CodeGuard, CryptoAuthentication, CryptoAutomotive, CryptoCompanion, CryptoController, dsPICDEM, dsPICDEM.net, Dynamic Average Matching, DAM, ECAN, Espresso T1S, EtherGREEN, IdealBridge, In-Circuit Serial Programming, ICSP, INICnet, Intelligent Paralleling, Inter-Chip Connectivity, JitterBlocker, maxCrypto, maxView, memBrain, Mindi, MiWi, MPASM, MPF, MPLAB Certified logo, MPLIB, MPLINK, MultiTRAK, NetDetach, Omniscient Code Generation, PICDEM, PICDEM.net, PICkit, PICtail, PowerSmart, PureSilicon, QMatrix, REAL ICE, Ripple Blocker, RTAX, RTG4, SAM-ICE, Serial Quad I/O, simpleMAP, SimpliPHY, SmartBuffer, SMART-I.S., storClad, SQI, SuperSwitcher, SuperSwitcher II, Switchtec, SynchroPHY, Total Endurance, TSHARC, USBCheck, VariSense, VectorBlox, VeriPHY, ViewSpan, WiperLock, XpressConnect, and ZENA are trademarks of Microchip Technology Incorporated in the U.S.A. and other countries.

SQTP is a service mark of Microchip Technology Incorporated in the U.S.A.

The Adaptec logo, Frequency on Demand, Silicon Storage Technology, and Symmcom are registered trademarks of Microchip Technology Inc. in other countries.

GestIC is a registered trademark of Microchip Technology Germany II GmbH & Co. KG, a subsidiary of Microchip Technology Inc., in other countries.

All other trademarks mentioned herein are property of their respective companies.

© 2020-2021, Microchip Technology Incorporated, All Rights Reserved.

ISBN: 978-1-5224-7800-3

For information regarding Microchip's Quality Management Systems, please visit www.microchip.com/quality.



MICROCHIP

Worldwide Sales and Service

AMERICAS

Corporate Office
2355 West Chandler Blvd.
Chandler, AZ 85224-6199
Tel: 480-792-7200
Fax: 480-792-7277
Technical Support:
<http://www.microchip.com/support>
Web Address:
www.microchip.com

Atlanta

Duluth, GA
Tel: 678-957-9614
Fax: 678-957-1455

Austin, TX

Tel: 512-257-3370

Boston

Westborough, MA
Tel: 774-760-0087
Fax: 774-760-0088

Chicago

Itasca, IL
Tel: 630-285-0071
Fax: 630-285-0075

Dallas

Addison, TX
Tel: 972-818-7423
Fax: 972-818-2924

Detroit

Novi, MI
Tel: 248-848-4000

Houston, TX

Tel: 281-894-5983

Indianapolis

Noblesville, IN
Tel: 317-773-8323
Fax: 317-773-5453
Tel: 317-536-2380

Los Angeles

Mission Viejo, CA
Tel: 949-462-9523
Fax: 949-462-9608
Tel: 951-273-7800

Raleigh, NC

Tel: 919-844-7510

New York, NY

Tel: 631-435-6000

San Jose, CA

Tel: 408-735-9110
Tel: 408-436-4270

Canada - Toronto

Tel: 905-695-1980
Fax: 905-695-2078

ASIA/PACIFIC

Australia - Sydney
Tel: 61-2-9868-6733

China - Beijing
Tel: 86-10-8569-7000

China - Chengdu
Tel: 86-28-8665-5511

China - Chongqing
Tel: 86-23-8980-9588

China - Dongguan
Tel: 86-769-8702-9880

China - Guangzhou
Tel: 86-20-8755-8029

China - Hangzhou
Tel: 86-571-8792-8115

China - Hong Kong SAR
Tel: 852-2943-5100

China - Nanjing
Tel: 86-25-8473-2460

China - Qingdao
Tel: 86-532-8502-7355

China - Shanghai
Tel: 86-21-3326-8000

China - Shenyang
Tel: 86-24-2334-2829

China - Shenzhen
Tel: 86-755-8864-2200

China - Suzhou
Tel: 86-186-6233-1526

China - Wuhan
Tel: 86-27-5980-5300

China - Xian
Tel: 86-29-8833-7252

China - Xiamen
Tel: 86-592-2388138

China - Zhuhai
Tel: 86-756-3210040

ASIA/PACIFIC

India - Bangalore
Tel: 91-80-3090-4444

India - New Delhi
Tel: 91-11-4160-8631

India - Pune
Tel: 91-20-4121-0141

Japan - Osaka
Tel: 81-6-6152-7160

Japan - Tokyo
Tel: 81-3-6880-3770

Korea - Daegu
Tel: 82-53-744-4301

Korea - Seoul
Tel: 82-2-554-7200

Malaysia - Kuala Lumpur
Tel: 60-3-7651-7906

Malaysia - Penang
Tel: 60-4-227-8870

Philippines - Manila
Tel: 63-2-634-9065

Singapore
Tel: 65-6334-8870

Taiwan - Hsin Chu
Tel: 886-3-577-8366

Taiwan - Kaohsiung
Tel: 886-7-213-7830

Taiwan - Taipei
Tel: 886-2-2508-8600

Thailand - Bangkok
Tel: 66-2-694-1351

Vietnam - Ho Chi Minh
Tel: 84-28-5448-2100

EUROPE

Austria - Wels
Tel: 43-7242-2244-39
Fax: 43-7242-2244-393

Denmark - Copenhagen
Tel: 45-4485-5910
Fax: 45-4485-2829

Finland - Espoo
Tel: 358-9-4520-820

France - Paris
Tel: 33-1-69-53-63-20
Fax: 33-1-69-30-90-79

Germany - Garching
Tel: 49-8931-9700

Germany - Haan
Tel: 49-2129-3766400

Germany - Heilbronn
Tel: 49-7131-72400

Germany - Karlsruhe
Tel: 49-721-625370

Germany - Munich
Tel: 49-89-627-144-0
Fax: 49-89-627-144-44

Germany - Rosenheim
Tel: 49-8031-354-560

Israel - Ra'anana
Tel: 972-9-744-7705

Italy - Milan
Tel: 39-0331-742611
Fax: 39-0331-466781

Italy - Padova
Tel: 39-049-7625286

Netherlands - Drunen
Tel: 31-416-690399
Fax: 31-416-690340

Norway - Trondheim
Tel: 47-7288-4388

Poland - Warsaw
Tel: 48-22-3325737

Romania - Bucharest
Tel: 40-21-407-87-50

Spain - Madrid
Tel: 34-91-708-08-90
Fax: 34-91-708-08-91

Sweden - Gothenberg
Tel: 46-31-704-60-40

Sweden - Stockholm
Tel: 46-8-5090-4654

UK - Wokingham
Tel: 44-118-921-5800
Fax: 44-118-921-5820