

1.SCOPE

SHOULDER's SAW filter series have broad line up products meeting all broadcast standard including NTSC,PAL and SECAM systems. These filters are composed of two interdigital transducers on a single-crystal, piezoelectrical chip. they are used in electronic equipments such as TV and so on.

2.Construction

2.1 Dimension and materials

Manufacturer's name : SHOULDER ELECTRONICS LIMITED

Type : MIF38A1M

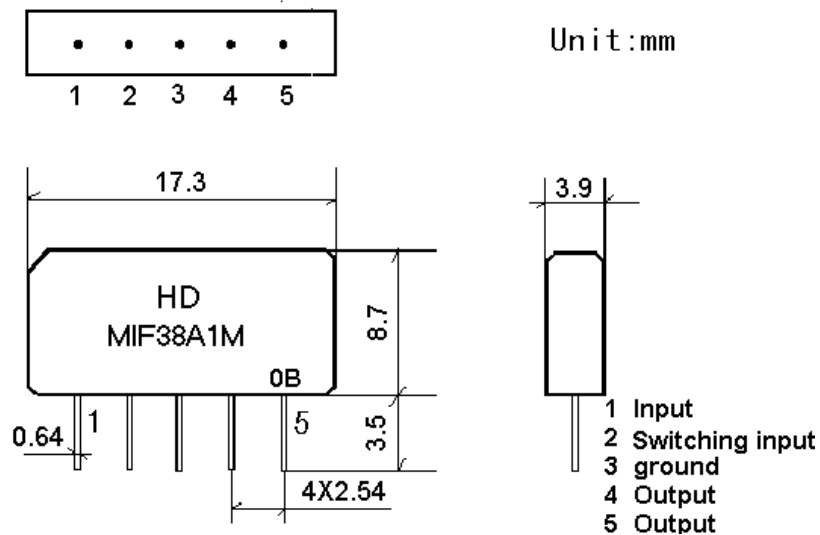

0: year(0,1,2,3,4,5,6,7,8,9)

B:product in this quarter(A:1~3,B:4~6,C:7~9,D:10~12)

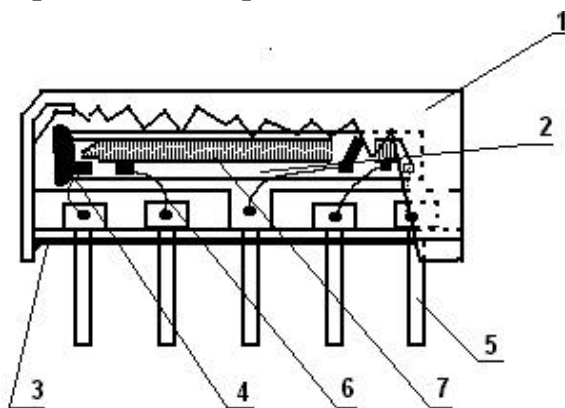

Components	Materials
1.Outer casing	PPS
2.Substrate	Lithium niobate
3.Base	Epoxy resin
4.Absorber	Epoxy resin
5.Lead	Cu alloy+Au plate
6.Bonding wire	AlSi alloy
7.Electrode	Al

2.2. Circuit construction, measurement circuit

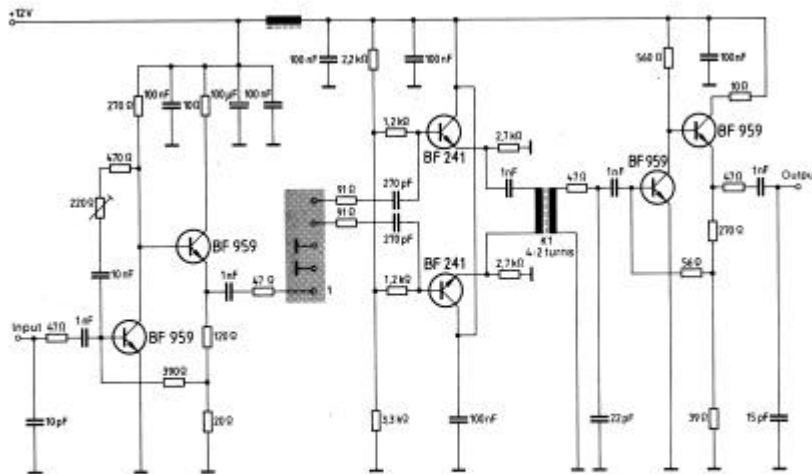

Test circuit for SIP-5 filter
Input impedance of the symmetrical post-amplifier: 2 kΩ in parallel with 3 pF

3.Characteristics

Standard atmospheric conditions

Unless otherwise specified , the standard rang of atmospheric conditions for making measurements and tests is as follows;

- Ambient temperature : 15 to 35
- Relative humidity : 25% to 85%
- Air pressure : 86kPa to 106kPa

Operating temperature rang

Operating temperature rang is the rang of ambient temperatures in which the filter can be

operated continuously. -10 ~ +60

Storage temperature rang

Storage temperature rang is the rang of ambient temperatures at which the filter can be stored

without damage.

Conditions are as specified elsewhere in these specifications. -40 ~ +70

Reference temperature +25

3.1 Maximum Rating

DC voltage	VDC	12	V	Between any terminals
AC voltage	Vpp	10	V	Between any terminals

3.2 Electrical Characteristics**Characteristics in BG/I/DK,M/N mode (switching input pin 2 connected to ground pin****3)**

Source impedance

 $Z_s=50$

Load impedance

 $Z_L=2k //3pF$ $T_A=25$

Item	Freq	min	typ	max	
Insertion attenuation Reference level	36.50MHz	15.7	17.7	19.7	dB
Relative attenuation	38.00MHz	4.2	5.7	7.2	dB
	33.57MHz	-0.3	1.2	2.7	dB
	31.50MHz	18.0	20.0	22.0	dB
	32.50MHz	17.6	19.6	-	dB
	30.00MHz	40.0	50.0	-	dB
	31.00MHz	37.0	54.0	-	dB
	39.50MHz	40.0	45.0	-	dB
Sidelobe	25.00~30.00MHz	35.0	44.0		dB
	39.50~45.00MHz	32.0	39.0		dB
Reflected wave signal suppression 1.3 us ... 6.0 us after main pulse (test pulse 250 ns , carrier frequency 36.50 MHz)		40.0	50.0		dB
Feedthrough signal suppression 1.2 us ... 6.0 us after main pulse (test pulse 250 ns , carrier frequency 36.50 MHz)		42.0	52.0		dB
Temperature coefficient			-72		ppm/k

Characteristics in M/N mode (switching input pin 2 connected to input pin 1)

Source impedance

 $Z_s=50$

Load impedance

 $Z_L=2k //3pF$ $T_A=25$

Item	Freq	min	Typ	max	
Insertion attenuation Reference level	36.50MHz	15.5	17.5	19.5	dB
Relative attenuation	38.00MHz	4.7	6.2	7.7	dB
	34.42MHz	2.3	3.8	5.3	dB
	33.50MHz	17.8	19.8	21.8	dB
	32.00MHz	37.0	45.0	-	dB
	39.50MHz	35.0	43.0	-	dB
Sidelobe	25.00~32.00MHz	35.0	41.0		dB
	39.50~45.00MHz	30.0	37.0		dB
Reflected wave signal suppression 1.3 us ... 6.0 us after main pulse (test pulse 250 ns , carrier frequency 36.50 MHz)		40.0	50.0		dB
Feedthrough signal suppression 1.2 us ... 6.0 us after main pulse (test pulse 250 ns , carrier frequency 36.50 MHz)		42.0	48.0		dB

Temperature coefficient	-72	ppm/k
-------------------------	-----	-------

3.3 Environmental Performance Characteristics

Item Test condition	Allowable change of absolute Level at center frequency(dB)
High temperature test 70 1000H	< 1.0
Low temperature test -40 1000H	< 1.0
Humidity test 40 90-95% 1000H	< 1.0
Thermal shock -20 ==25 ==80 20 cycle 30M 10M 30M	< 1.0
Solder temperature test Sold temp.260 for 10 sec.	< 1.0
Soldering Immerse the pins melt solder at 260 +5/-0 for 5 sec.	More then 95% of total area of the pins should be covered with solder

3.4 Mechanical Test

Item Test condition	Allowable change of absolute Level at center frequency(dB)
Vibration test 600-3300rpm amplitude 1.5mm 3 directions 2 H each	<1.0
Drop test On maple plate from 1 m high 3 times	<1.0
Lead pull test Pull with 1 kg force for 30 seconds	<1.0
Lead bend test 90° bending with 500g weigh 2 times	<1.0

3.5 Voltage Discharge Test

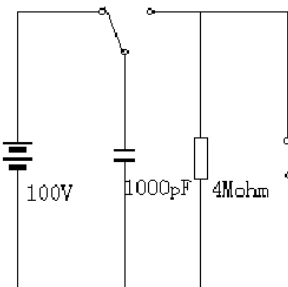
Item Test condition	Allowable change of absolute Level at center frequency(dB)
Surge test Between any two electrode 	<1.0

