

種別/Type	シリコン MOS形集積回路/Silicon MOSFET type Integrated Circuit						
用途/Application	スイッチング電源制御用/For Switching Power Supply Control						
構造/Structure	CMOS形/CMOS type						
等価回路/Equivalent Circuit	添付図/See Figure. 6						
外形/Out Line	DIP7-A1-B		マーク記号/マーキング/Marking			MIP2F4	
A. 絶対最大定格/ABSOLUTE MAXIMUM RATINGS (Ta=25°C±3°C)							
NO.	項目/Item	記号/Symbol	定格/Ratings	単位/Unit	備考/Note		
1	ドレイン電圧 DRAIN Voltage	VD	-0.3 ~ 700	V	※1: 下記パルス幅以内での保証とする (It is guaranteed within the pulse as below.) オン時ブランキング幅 + 過電流保護遅れ時間 Leading Edge Blanking Pulse + Current Limit Delay ton(BLK) + td(OCL)		
2	VCC電圧 VCC Voltage	VCC	-0.3 ~ 45	V			
3	VDD電圧 VDD Voltage	VDD	-0.3 ~ 8	V			
4	フィードバック電圧 FEEDBACK Voltage	VFB	-0.3 ~ 8	V			
5	フィードバック電流 FEEDBACK Current	IFB	500	uA			
6	CL端子電圧 CL Voltage	VCL	-0.3 ~ 8	V			
7	CL端子電流 CL Current	ICL	150	uA			
8	出力ピーク電流 Output Peak Current	IDP	1.5 (※1)	A			
9	チャネル部温度 Channel Temperature	Tch	150	°C			
10	保存温度 Storage Temperature	Tstg	-55 ~ +150	°C			
B. 電気的特性/ELECTRICAL CHARACTERISTICS							
			測定条件/Measure condition (TC=25°C±2°C)				
No.	項目/Item	記号/Symbol	測定条件/Measure Condition (測定図-1 参照/See Figure 1)	Typ.	Limit		Unit
					Min	Max	
【コントロール機能/CONTROL FUNCTIONS】							
1	出力周波数 Output Frequency	fosc	VCC=15 V, VD=5 V, IFB=20 uA, ICL=50 uA	100	90	110	kHz
		fosc(L)	VCC=15 V, VD=5 V, IFB:OPEN, ICL<ICL1	12	9	15	kHz
2	最大デューティサイクル Maximum Duty Cycle	MAXDC	VCC=15 V, VD=5 V, IFB=20 uA, ICL=50 uA	47.5	45	50	%
3	VDD基準電圧 VDD Voltage	VDD	VCC=15 V, VD=5 V, IFB=20 uA, ICL=50 uA	5.9	5.4	6.4	V
4	VDD停止電圧 UV Lockout Threshold Voltage	VUV	VD=5 V, IFB=20 uA, ICL=50 uA	5.1	4.6	5.6	V

No.	項目/Item	記号/ Symbol	測定条件/Measure Condition (測定図-1 参照/See Figure 1)	Typ.	Limit		Unit
					Min	Max	
【コントロール機能/CONTROL FUNCTIONS】							
5	VCC起動電圧 VCC Start Voltage	VCC(ON)	VD=5 V, IFB=20 μ A, ICL=50 μ A	7.5	6.5	8.5	V
6	VCC充電停止電圧 VCC Charge Stop Threshold Voltage	VCC1	VD=40 V, FB:OPEN, CL:OPEN	12	11	13	V
7	フィードバック電流 Feedback Threshold Current	IFB1	ON \rightarrow OFF VCC=15 V, VD=5 V, ICL=50 μ A	80	50	110	μ A
8	フィードバック電流ヒステリシス Feedback Hysteresis Current	IFBHYS	VCC=15 V, VD=5 V, ICL=50 μ A	6			μ A
9	重負荷時FB端子電流 FB Pin Current at Heavy Load	IFB0	ICC0 \rightarrow ICC VCC=15 V, VD=5 V, ICL=50 μ A	11	7	15	μ A
10	FB端子電圧 FB Pin Voltage	VFB	VCC=15 V, VD=5 V, IFB=20 μ A, ICL=50 μ A	1.0	0.7	1.3	V
11	回路消費電流 Supply Current	ICC	VCC=15 V, VD=5 V, IFB=20 μ A, ICL=50 μ A	0.45	0.25	0.55	mA
12	軽負荷時回路消費電流 Supply Current at Light Load	ICC(OFF)	VCC=15 V, VD=5 V IFB=IFB1+5 μ A, ICL=50 μ A	0.27	0.2	0.35	mA
13	重負荷時回路消費電流 Supply Current at Heavy Load	ICC0	VCC=15 V, VD=5 V, IFB=OPEN, ICL=50 μ A	0.63	0.48	0.78	mA
14	VDD充電電流 VDD Charging Current	Ich1	VDD=0 V, VD=40 V, FB:OPEN, CL:OPEN	7	5	9	mA
		Ich2	VDD=4 V, VD=40 V, FB:OPEN, CL:OPEN	2.3	1	3.6	mA
15	CL端子電圧 CL Pin Voltage	VCL	VCC=15 V, VD=5 V, FB:OPEN, ICL=15 μ A	2.3	2.0	2.6	V
16	fosc 低下時CL端子電流 Dropped fosc CL Pin Current	ICL1	fosc \rightarrow fosc(L) ※Figure 3 VCC=15 V, VD=5 V, FB:OPEN	12	9	15	μ A
17	fosc 低下時CL端子電流ヒステリシス CL Pin Hysteresis Current	ICLHYS	※Figure 3 VCC=15 V, VD=5 V, FB:OPEN	1.0			μ A
【保護機能/CIRCUIT PROTECTIONS: *は設計保証項目/Design Guarantee Item】							
18	過電流保護検出 Self Protection Current Limit	ILIMIT	※Figure 2/Figure 4 VCC=15 V, FB:OPEN, ICL=50 μ A, DUTY=30%	0.70	0.63	0.77	A
19	ILIMIT 補正係数 ILIMIT modified coefficient	R_slope	※Figure 2/Figure 4 VCC=15 V, FB:OPEN, ICL=50 μ A	40			mA/us
20	最小ILIMIT Minimum ILIMIT	ILIMITmin	Ton=3 μ sec VCC=15 V, FB:OPEN, ICL=0 μ A	170	90	250	mA
*	軽負荷時ドレイン電流 Drain Current at Light Load	ID(OFF)	Ton=3 μ sec VCC=15 V, IFB=IFB1+IFBHYS, ICL=50 μ A	140	50	230	mA
*	オン時ブランキング幅 Leading Edge Blanking Delay	ton(BLK)	VCC=15 V, FB:OPEN, ICL=50 μ A	240	170	310	ns
*	過電流保護遅れ時間 Current Limit Delay	td(OCL)		150	100	200	ns
24	過電圧保護検出 Over Voltage Protection	VCC(OV)	VDD=5 V, FB:OPEN, ICL=50 μ A	24	21	27	V
*	過熱保護温度 Thermal Shutdown Temperature	TOTP		140	130	150	$^{\circ}$ C

No.	項目/Item	記号/ Symbol	測定条件/Measure Condition (測定図-1 参照/See Figure 1)	Typ.	Limit		Unit
					Min	Max	
【出力/OUTPUT】							
26	ラッチリセット電圧 Power-up Reset Threshold Voltage	VDDreset		2.6	1.8	3.5	V
27	オン抵抗 ON-State Resistance	RDS(ON)	ID=100 mA	7		9.5	Ω
28	オフ時ドレイン端子リーク電流 OFF-State Current	IDSS	VCC=27 V, VD=650 V, FB:OPEN, CL:OPEN	10		20	μA
29	ドレイン耐圧 Breakdown Voltage	VDSS	VCC=27 V, ID=100 μA, FB:OPEN, CL:OPEN		700		V
30	立ち上がり時間 Rise Time	tr	※Figure 5 VCC=15 V, VD=5 V, FB:OPEN, ICL=50 μA	100			ns
31	立ち下がり時間 Fall Time	tf	※Figure 5 VCC=15 V, VD=5 V, FB:OPEN, ICL=50 μA	50			ns
【電源電圧/SUPPLY】							
32	最小ドレイン電圧 Drain Supply Voltage	VD(MIN)	VCC:OPEN, FB:OPEN, CL:OPEN		50		V

【Fig. 1 : 測定回路図/Measure Circuit】

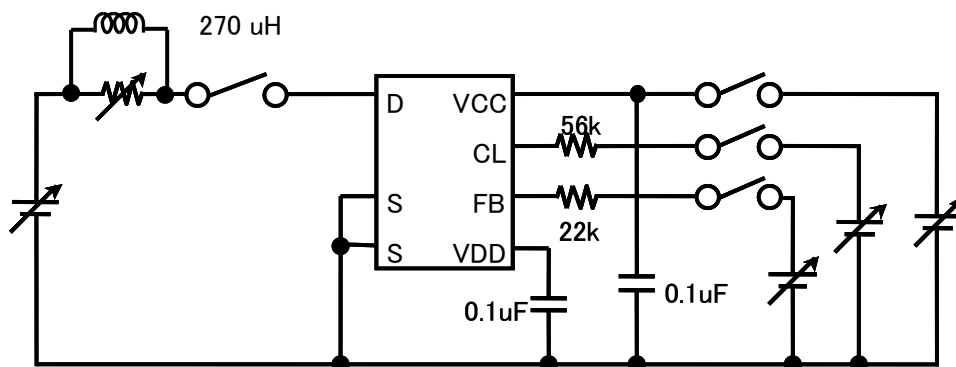

【Fig. 2: ILIMIT vs. ICL Typical Characteristic】

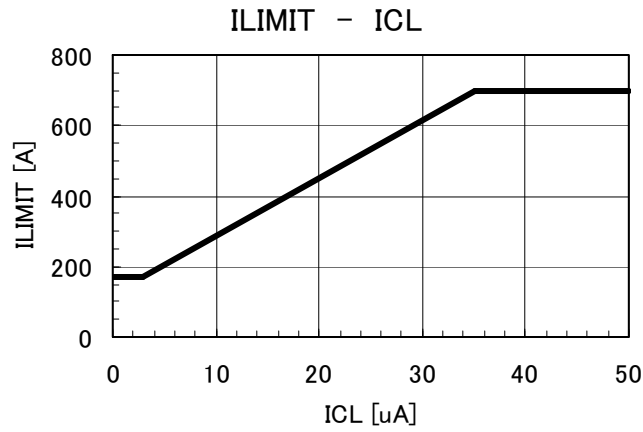

【Fig. 3: fosc vs. ICL Typical Characteristic】

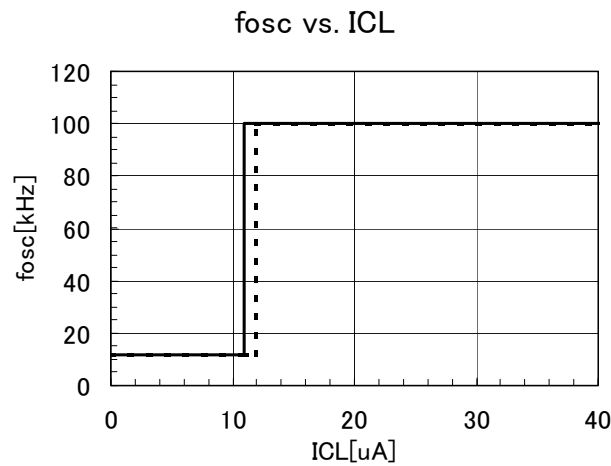

【Fig. 4: ILIMIT Measurement】

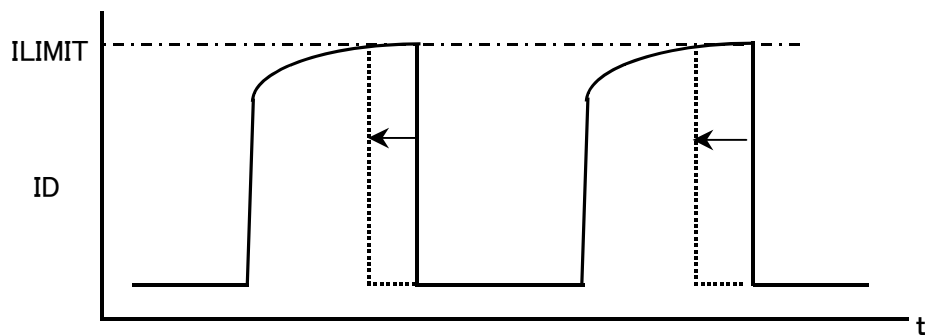

$$R_slope ; \{ (ILIMIT \text{ at Duty}=30\%) - (ILIMIT \text{ at Duty}=10\%) \} / \{ (Ton \text{ at Duty}=30\%) - (Ton \text{ at Duty}=10\%) \}$$

【Fig. 5 : tr, tf Measurement】

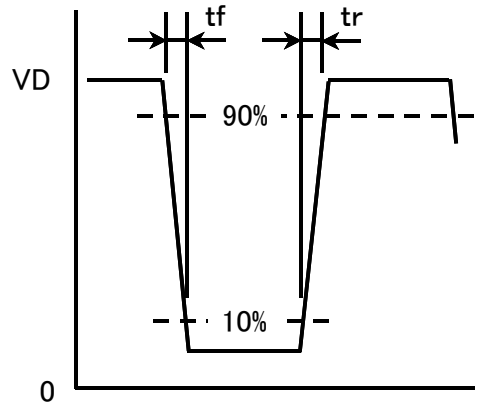

【Fig. 6 : Block Diagram】

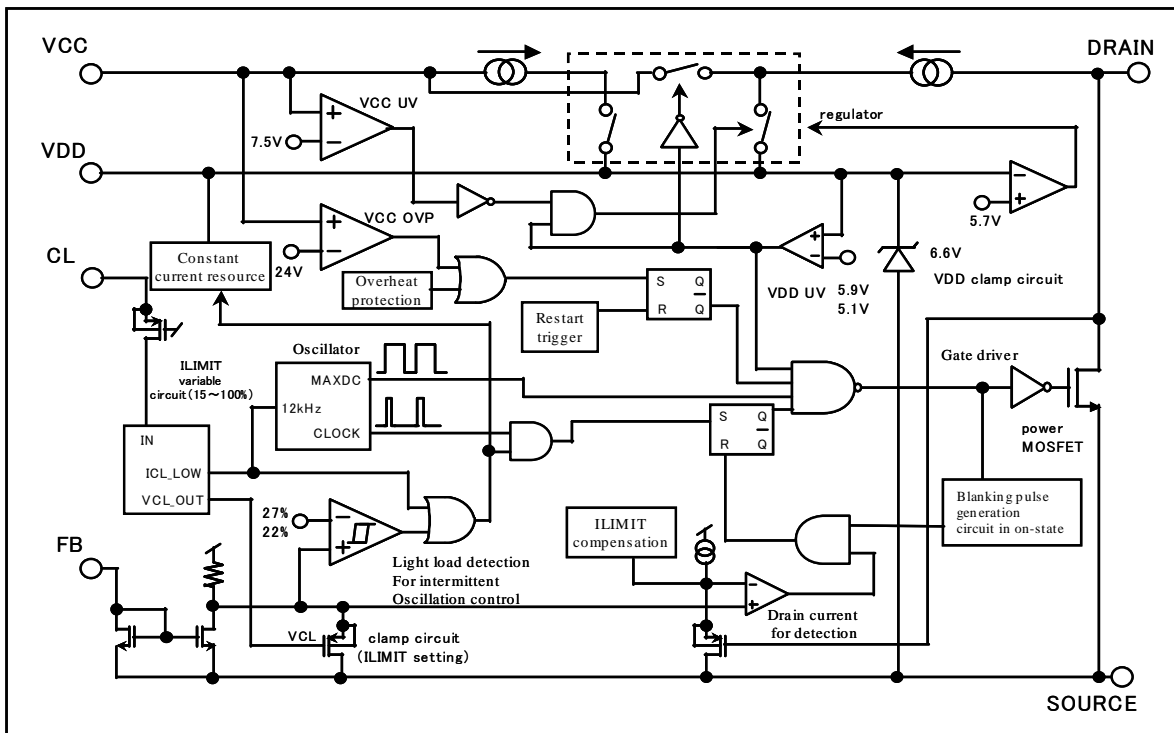

【Fig. 7: 端子配置図／Pin Layout】

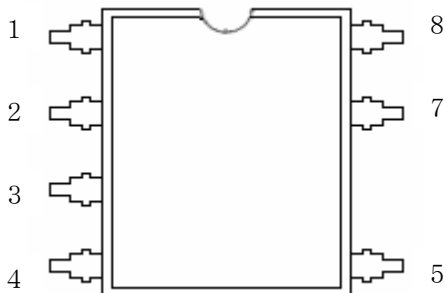

Pin No.	端子名／Terminal Name
1	VDD
2	FB
3	CL
4	VCC
5	Drain
6	—
7	Source
8	Source

【使用上の注意1／Precautions for Use 1】

VDD 端子—GND間には、0.1 μ Fのセラミックコンデンサを使用してください。
Connect a 0.1 μ F ceramic capacitor between VDD pin and GND.

【使用上の注意2／Precautions for Use 2】

以下のような条件では破損し、場合によっては破裂、発煙の可能性があります。以下の使用は避けてください。
The IPD has risks for break-down or burst or giving off smoke in following conditions. Avoid the following use.

- (1) DRAIN 端子と VDD 端子を逆にして、電源基板へ挿入する。
Reverse the DRAIN pin and VDD pin connection to the power supply board.
- (2) DRAIN 端子と VDD 端子をショートする。
DRAIN pin short to VDD pin.
- (3) DRIN端子と FB 端子をショートする。
DRAIN pin short to FB pin.
- (4) DRIN端子とCL端子をショートする。
DRAIN pin short to CL pin.
- (5) DRIN端子と VCC 端子をショートする。
DRAIN pin short to VCC pin.
- (6) VCC 端子と VDD 端子をショートする。
VCC pin short to VDD pin.
- (7) VCC 端子と FB 端子をショートする。
VCC pin short to FB pin.
- (8) VCC 端子と CL 端子をショートする。
VCC pin short to CL pin.

Request for your special attention and precautions in using the technical information and semiconductors described in this book

- (1) If any of the products or technical information described in this book is to be exported or provided to non-residents, the laws and regulations of the exporting country, especially, those with regard to security export control, must be observed.
- (2) The technical information described in this book is intended only to show the main characteristics and application circuit examples of the products. No license is granted in and to any intellectual property right or other right owned by Panasonic Corporation or any other company. Therefore, no responsibility is assumed by our company as to the infringement upon any such right owned by any other company which may arise as a result of the use of technical information described in this book.
- (3) The products described in this book are intended to be used for general applications (such as office equipment, communications equipment, measuring instruments and household appliances), or for specific applications as expressly stated in this book.
Consult our sales staff in advance for information on the following applications:
 - Special applications (such as for airplanes, aerospace, automotive equipment, traffic signaling equipment, combustion equipment, life support systems and safety devices) in which exceptional quality and reliability are required, or if the failure or malfunction of the products may directly jeopardize life or harm the human body.
 It is to be understood that our company shall not be held responsible for any damage incurred as a result of or in connection with your using the products described in this book for any special application, unless our company agrees to your using the products in this book for any special application.
- (4) The products and product specifications described in this book are subject to change without notice for modification and/or improvement. At the final stage of your design, purchasing, or use of the products, therefore, ask for the most up-to-date Product Standards in advance to make sure that the latest specifications satisfy your requirements.
- (5) When designing your equipment, comply with the range of absolute maximum rating and the guaranteed operating conditions (operating power supply voltage and operating environment etc.). Especially, please be careful not to exceed the range of absolute maximum rating on the transient state, such as power-on, power-off and mode-switching. Otherwise, we will not be liable for any defect which may arise later in your equipment.
Even when the products are used within the guaranteed values, take into the consideration of incidence of break down and failure mode, possible to occur to semiconductor products. Measures on the systems such as redundant design, arresting the spread of fire or preventing glitch are recommended in order to prevent physical injury, fire, social damages, for example, by using the products.
- (6) Comply with the instructions for use in order to prevent breakdown and characteristics change due to external factors (ESD, EOS, thermal stress and mechanical stress) at the time of handling, mounting or at customer's process. When using products for which damp-proof packing is required, satisfy the conditions, such as shelf life and the elapsed time since first opening the packages.
- (7) This book may be not reprinted or reproduced whether wholly or partially, without the prior written permission of our company.

Precautions on the Sales of IPDs

- 1) The sale and/or the export of IPD products to customers located in certain countries is restricted by the Agreement made and executed by and between Power Integrations, Inc. and Panasonic Corporation. For details, refer to the following Attached table "IPD availability by customer."
- 2) IPD products purchased from our company, or its authorized agents, hereinafter referred to as our company, shall be used only for production purposes by those parties who have duly purchased IPD products. Those who have purchased IPD products shall not use such IPD products in unmodified form for re-sale, loan, or sample shipment for evaluation purposes to any other parties.
- 3) If a party who has duly purchased IPD products subcontracts its production to any other parties, including its subsidiaries or any other third parties inside and/or out of Japan, and the IPD products are consigned to such subcontracting parties thereat, such party is obligated to monitor and control the quantity of IPD products to prevent any of the aforementioned re-sale, loan or sample shipments from taking place.
- 4) In the event that any actual or threatened breach or violation of any of the above mentioned 2) or 3) has occurred or is about to occur, our company will hold all shipments of IPD products and may request the customer to disclose necessary documentation describing the status of our end-users and/or distribution channels.

Note) The products of MIP50**, MIP51**, and MIP7** are excluded from above-mentioned precautions, 1) to 3).

Attached table "IPD availability by customer"

Parts No.			Companies/areas to which products can be sold	Companies/areas to which products cannot be sold	Application
MIP01** MIP2** MIP9A**	MIP02** MIP3** MIP9L**	MIP1** MIP4**	<ul style="list-style-type: none"> · Japanese companies in Japan · Japanese companies in Asia (50% or more owned) 	<ul style="list-style-type: none"> · Companies in European and American countries · Asian companies in Asia · Other local companies 	<ul style="list-style-type: none"> · For power supply · For DC-DC converter
MIP00** MIP55** MIP803/804	MIP52** MIP56** MIP816/826	MIP53** MIP5S** MIP9E**	<ul style="list-style-type: none"> · Japanese companies in Japan · Japanese companies in Asia (50% or more owned) · Asian companies in Asia 	<ul style="list-style-type: none"> · Companies in European and American countries · Other local companies 	<ul style="list-style-type: none"> · For power supply · For EL driver · For LED lighting driver
MIP50**	MIP51**	MIP7**	<ul style="list-style-type: none"> · No restrictions in terms of contract 	<ul style="list-style-type: none"> · No restrictions in terms of contract 	<ul style="list-style-type: none"> · For lamp driver/ car electronics accessories

Note) For details, contact our sales division.