

Type	Silicon MOSFET type Integrated Circuit		
Application	For Switching Power Supply Control		
Structure	CMOS type		
Circuit Block Diagram	Figure 8		
Out Line	DIP7-A1-B	Marking	MIP2M2

**A. ABSOLUTE MAXIMUM RATINGS (Ta=25°C±3°C)**

NO.	Item	Symbol	Ratings	Unit	Note
1	DRAIN Voltage	VD	-0.3 ~ 700	V	VFB is guaranteed at VDD=6 V. VSO is guaranteed at VSO=VDD.  ※ 1: IDP is guaranteed at the pulse width narrower than ton(BLK) + td(OCL)
2	VCC Voltage	VCC	-0.3 ~ 45	V	
3	VDD Voltage	VDD	-0.3 ~ 9	V	
4	FB Voltage	VFB	-0.3 ~ 6.4	V	
5	FB Current	IFB	-500	μA	
6	LS Voltage	VLS	-0.3 ~ 10	V	
7	SO Voltage	VSO	-0.3 ~ 9	V	
8	Output Peak Current	IDP	0.76(※1)	A	
9	Recommended Operating Temperature	Tj	-30 ~ +125	°C	
10	Channel Temperature	Tch	150	°C	
11	Storage Temperature	Tstg	-55 ~ +150	°C	

**B. ELECTRICAL CHARACTERISTICS** Measure condition (TC=25°C±3°C)

No.	Item	Symbol	Measure Condition (Figure 1)	Typ	Min	Max	Unit
-----	------	--------	------------------------------	-----	-----	-----	------

**[CONTROL FUNCTIONS] \*Design guaranteed item**

1	Output Frequency	fosc	※ Figure 7 V4=15 V, V3=2 V, I2=-20 μA, V5=5 V	67	60.3	73.7	kHz
2	Jitter Frequency Deviation	d_fosc	※ Figure 7 V4=15 V, V3=2 V, I2=-20 μA, V5=5 V	5.0	2.4	7.6	kHz
*3	Jitter Frequency Modulation Rate	fM	※ Figure 7 V4=15 V, V3=2 V, I2=-20 μA, V5=5 V	360	-	-	Hz
4	Maximum Duty Cycle	MAXDC	V4=15 V, V3=2 V, I2=-20 μA, V5=5 V	54	50	58	%
5	VDD Voltage	VDD	V4=15 V, V3=6 V, I2=-20 μA, V5=5 V, V6=1 V	5.9	5.4	6.4	V
6	VCC Start Voltage	VCC(ON)	V3=6 V, I2=-20 μA, V5=5 V, V6=1 V	12	11	13	V

7	VCC Stop Voltage	VCC(OFF)	V3=6 V, I2=-20 $\mu$ A, V5=5 V, V6=1 V	8.2	7.45	8.95	V
8	VCC start/stop Hysteresis	VCC(HYS)	VCC(ON) - VCC(OFF)	3.8	3.1	4.5	V
9	Feedback Threshold Current	IFB1	ON→OFF V4=15 V, V3=6 V, V5=5 V, V6=1 V	-57	-81	-34	$\mu$ A
10	Feedback Current Hysteresis	IFB(HYS)	OFF→ON V4=15 V, V3=6 V, V5=5 V, V6=1 V	1.5	-	-	$\mu$ A
11	FB Pin Voltage	VFB1	V4=15 V, V3=6 V, I2= IFB1, V5=5 V, V6=1 V	1.9	1.6	2.2	V
12	Circuit Current before start	ICC(SB)	V4=6.5 V, V3=6 V, I2=-20 $\mu$ A, V5=5 V, V6=1 V	0.25	0.20	0.30	mA
13	Circuit Current	ICC	V4=15 V, V3=6 V, I2=-20 $\mu$ A, V5=5 V, V6=1 V	0.36	0.23	0.49	mA
14	VDD Charging Current	Ich1	V1=0 V, V5=40 V	-2.2	-3.3	-1.1	mA
		Ich2	V1=4 V, V5=40 V	-1.3	-2.1	-0.6	mA
15	LS start voltage	VLSH	V4=VCC(OFF)→VCC(ON), V3=6 V, I2=-20 $\mu$ A, V5=5 V	540	486	594	mV
16	LS stop voltage	VLSL	V4=15 V, V3=6 V, I2=-20 $\mu$ A, V5=5 V	395	355	435	mV
17	LS detect Hysteresis	VLSHYS	VLSH - VLSL	145	-	-	mV
18	LS start/stop mode filter time	TLStop	V4=15 V, V3=6 V, I2=-20 $\mu$ A, V5=5 V V6=VLSH→VLSL	5.85	4.2	7.5	ms
19	LS detect SO signal mode filter time	TLSSO	V4=15 V, V3=6 V, I2=-20 $\mu$ A, V5=5 V	3.15	1.85	4.45	ms
20	SO output voltage	VSO	V4=15 V, I2=-20 $\mu$ A, V5=5 V V6=VLSH→VLSL	4.2	3.2	5.2	V
No.	Item	Symbol	Measure Condition (Figure 1)	Typ	Min	Max	Unit
21	SO output current	ISO	V4=15 V, V3=1V, I2=-20 $\mu$ A, V5=5 V V6=0 V	-0.8	-1.2	-0.4	mA
22	SO Disable Threshold	VSOTH	V4=15 V, I2=-20 $\mu$ A, V5=5 V, V6=0 V	5.2	4.6	5.8	V
23	SO Disable Threshold difference	D_VSO	VSOTH-VSO	1.0	0.7	1.3	V
24	SO pull down current	ISO_down	V4=15 V, V3=1 V, I2=-20 $\mu$ A, V5=5 V V6=0 V	0.7	0.3	1.1	$\mu$ A
25	Soft start time	Tsoft	V4=VCC(OFF)→VCC(ON) I2=-20 $\mu$ A, V5=5 V, V6=1 V	8.5	5	12	ms

**[CIRCUIT PROTECTIONS]**

26	Self Protection Current Limit	ILIMIT	※Figure 5 Duty=30 % V4=15 V, V3=2 V, V2=2.6 V, V5=adjusted	0.35	0.315	0.385	A
27	ILIMIT modified coefficient	R_slope	※Figure 5 Duty=10 % V4=15 V, V3=2 V, V2=2.6 V, V5=adjusted	10	-	-	mA/ $\mu$ s
*28	Drain Current at Light Load	ID(OFF)	Ton=4.5 $\mu$ sec, V4=15 V, V3=2 V, I2=IFB1+IFB(HYS)+2 $\mu$ A, V5=adjusted	100	40	160	mA
29	FB current at heavy load	IFBOLP	V5=ILIMIT condition V4=15 V, V3=2 V, V2=3 V, V6=1 V	-10	-13	-7	$\mu$ A
30	FB Over Load Protection detect voltage	VFBOLP	V5=ILIMIT condition V4=15 V, V3=2 V, V6=1 V	3.85	3.5	4.2	V

31	FB Over Load Protection Hysteresis	HYSVFBOLP		0.65	-	-	V
32	FB discharge current at timer intermittent	IFBOLPP	V5=ILIMIT condition, V4=VCC(OFF) V3=2 V, V2=25 V, V6=1 V	1.0	0.6	1.4	mA
33	FB current at MAXDC detect	IFBMAXDC	V4=15 V, V3=6 V, V2=3 V, V5=5 V, V6=1 V	-	-	0.2	μA
34	Timer intermittent function	TIMER	※Figure 3 V4=VCC(ON)⇔VCC(OFF), V5=ILIMIT condition, V3=6 V, I2=-20 μA, V6=1 V	4			
35	Timer intermittent function disabled at MAXDC	TIMER2	※Figure 4 V4=VCC(ON)⇔VCC(OFF), V5=ILIMIT condition, V3=6 V, I2=-20 μA, V6=1 V	1			
*36	Leading Edge Blanking Delay	ton(BLK)		290	230	350	ns
*37	Current Limit Delay	td(OCL)		150	100	200	ns
38	VCC Over Voltage Protection	VCC(OV)	V3=6 V, I2=-20 μA, V5=5 V, V6=1 V	29	26	32	V
39	VDD Over Voltage Protection	VDD(OV)	V4=15 V, I1=IDD(OV), V3=0 V, I2=-20 μA, V5=5 V, V6=6 V	7.0	6.40	7.50	V
40	VDD current at VDD Over Voltage Protection	IDD(OV)	V4=15 V, V3=0 V, I2=-20 μA, V5=5 V, V6=6 V	3.5	2.4	4.6	mA
41	VDD(OV) difference	D_VDDOV	VDD(OV)-VDD	0.9	0.4	1.5	V

No.	Item	Symbol	Measure Condition (Figure 1)	Typ	Min	Max	Unit
*42	Thermal Shutdown Temperature	TOTP		140	130	150	°C
43	Latch Reset VDD Threshold	VDDreset		2.7	1.8	3.5	V

**[OUTPUT]**

No.	Item	Symbol	Measure Condition (Figure 1)	Typ	Min	Max	Unit
44	ON-State Resistance	RDS(ON)	V4=15 V, V3=2 V I5=100 mA, I2=-20 μA, V6=1 V	16	-	21	Ω
45	OFF-State leakage Current	IDSS	V4=35 V, I2=-20 μA, V3=6 V, V5=650 V, V6=1 V	10	-	20	μA
46	Breakdown Voltage	VDSS	V4=35 V, I2=-20 μA, V3=6 V, I5=100 μA, V6=1 V	-	700	-	V
*47	Rise Time	tr	※Figure 6 V4=15 V, V3=1 V, I2=-20 μA, V5=5 V	70	-	-	ns
*48	Fall Time	tf	※Figure 6 V4=15 V, V3=1 V, I2=-20 μA, V5=5 V	35	-	-	ns

**[SUPPLY VOLTAGE]**

49	Drain Supply Voltage	VD(MIN)	V1, V2, V3, V4, V6 OPEN	-	50	-	V
----	----------------------	---------	-------------------------	---	----	---	---

【Figure 1: Measure circuit】

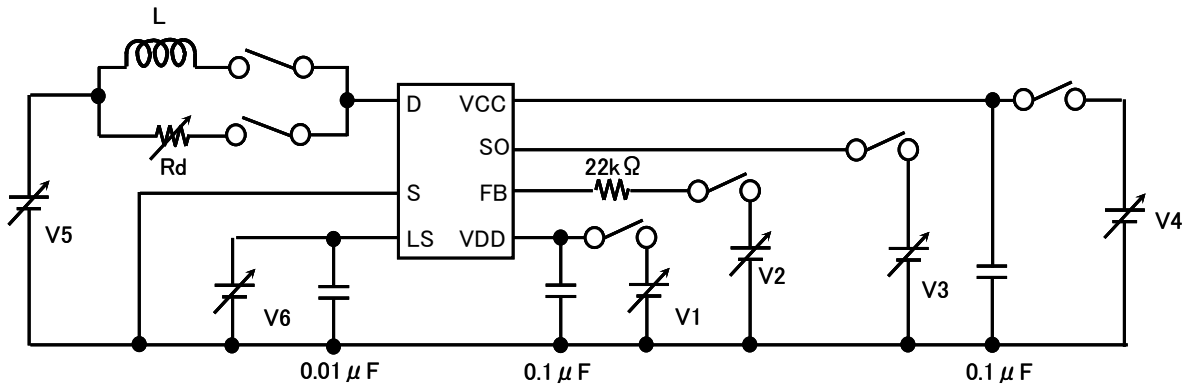

【Figure 2: Start up and Stop diagram】

(A) Usual start and stop of LS start/stop mode (SO is connected to VDD)

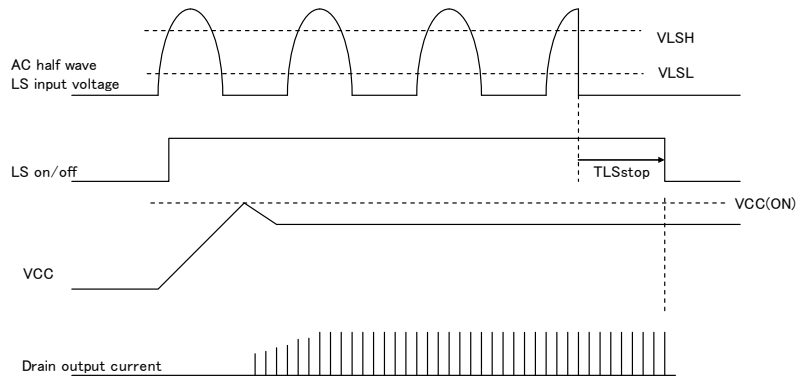

(B) Slow start and stop of LS start/stop mode (SO is connected to VDD)

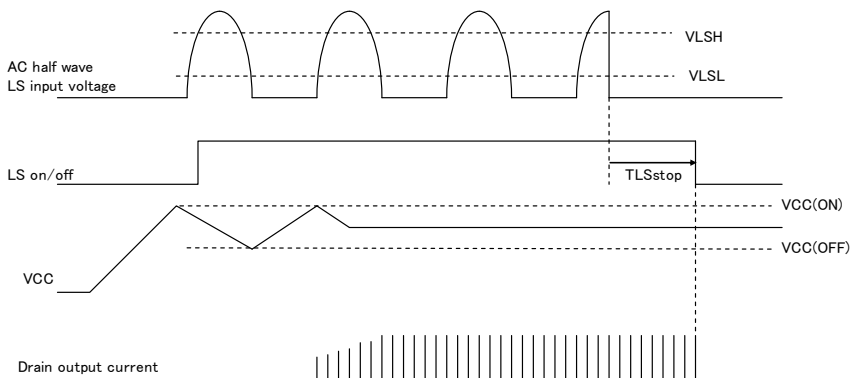

(C) Usual start and stop of LS detect SO signal mode (SO is connected to external parts)

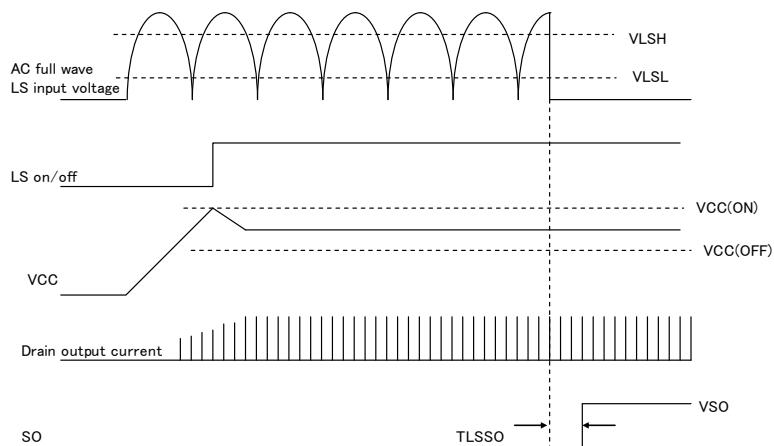

【Figure 3: Timer intermittent Over load protection diagram】

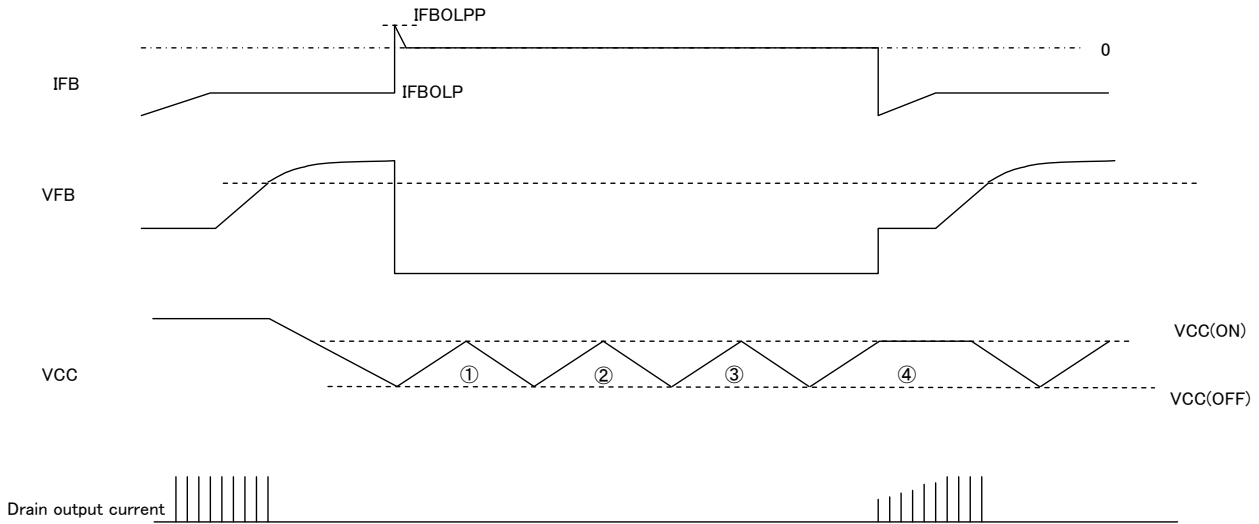

【Figure 4: OLP is disabled when MAXDC operation】

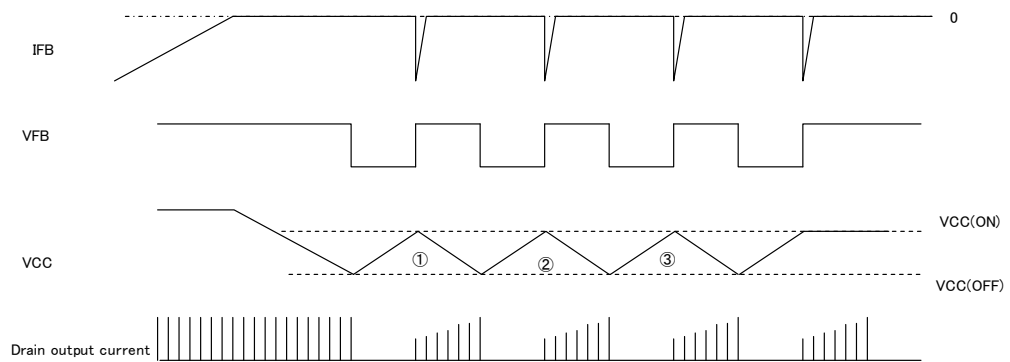

【Figure 5: I<sub>LIMIT</sub>, R\_Slope measurement】

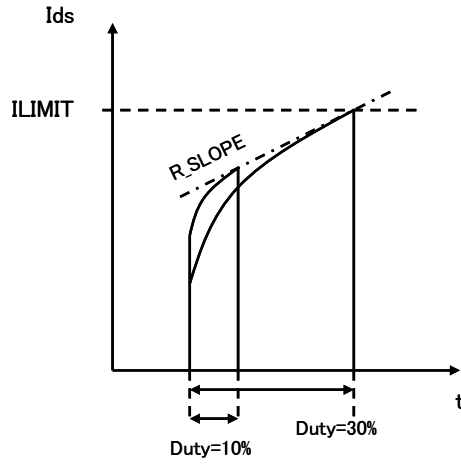

$$R_{slope} ; \{ (I_{LIMIT} \text{ at Duty}=30\%) - (I_{LIMIT} \text{ at Duty}=10\%) \} / \{ (T_{on} \text{ at Duty}=30\%) - (T_{on} \text{ at Duty}=10\%) \}$$

【Figure 6:  $t_r$ ,  $t_f$  measurement】

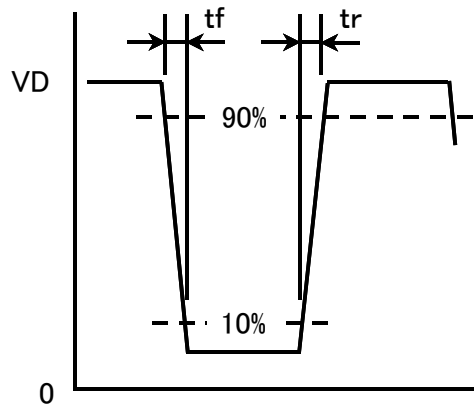

【Figure 7:  $d_{fosc}$ ,  $f_M$  measurement】

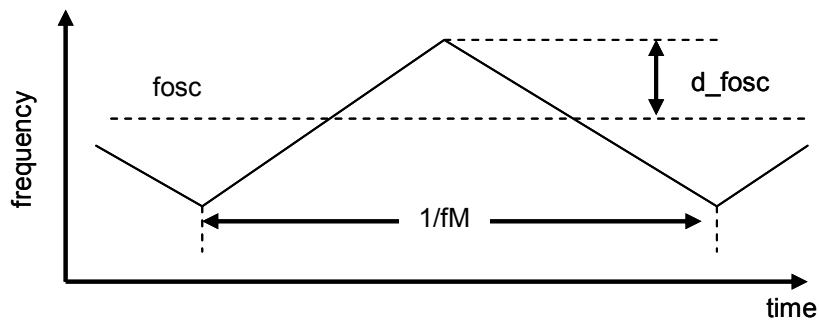

[Figure 8: Circuit Block Diagram]

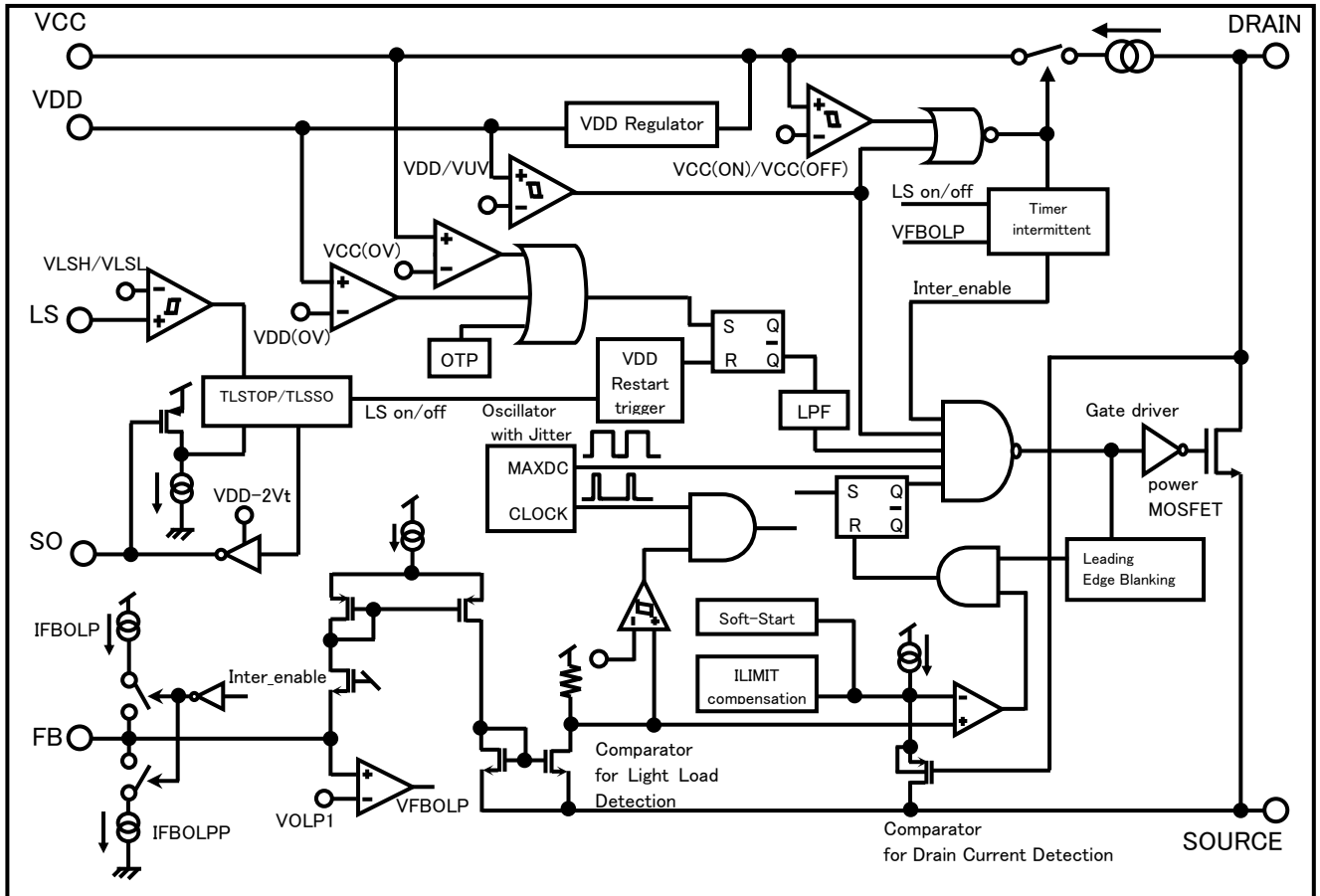

2010.02.17

[Figure 9: Pin Layout]

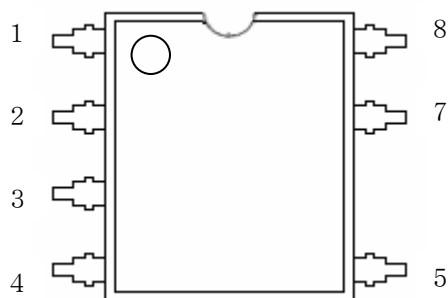

Pin No.	Terminal Name
1	VDD
2	FB
3	SO
4	VCC
5	Drain
6	—
7	Source
8	LS



### 【Precautions for Use 1】

Connect a ceramic capacitor with value  $>0.1 \mu F$  between VDD pin and GND.

### 【Precautions for Use 2】

The IPD has risks for break-down or burst or giving off smoke in following conditions. Avoid the following use.

Fuse should be added at the input side or connect zener diode between control pin and GND, etc as a countermeasure to pass regulatory Safety Standard. Concrete countermeasure could be provided individually. However, customer should make the final judgment.

- (1) Reverse the DRAIN pin and VDD pin connection to the power supply board.
- (2) DRAIN pin short to VDD pin.
- (3) DRAIN pin short to FB pin.
- (4) DRAIN pin short to SO pin.
- (5) DRAIN pin short to VCC pin.
- (6) DRAIN pin short to LS pin.
- (7) VCC pin short to VDD pin.
- (8) VCC pin short to FB pin.
- (9) VCC pin short to SO pin.

## Request for your special attention and precautions in using the technical information and semiconductors described in this book

- (1) If any of the products or technical information described in this book is to be exported or provided to non-residents, the laws and regulations of the exporting country, especially, those with regard to security export control, must be observed.
- (2) The technical information described in this book is intended only to show the main characteristics and application circuit examples of the products. No license is granted in and to any intellectual property right or other right owned by Panasonic Corporation or any other company. Therefore, no responsibility is assumed by our company as to the infringement upon any such right owned by any other company which may arise as a result of the use of technical information described in this book.
- (3) The products described in this book are intended to be used for general applications (such as office equipment, communications equipment, measuring instruments and household appliances), or for specific applications as expressly stated in this book.  
Consult our sales staff in advance for information on the following applications:
  - Special applications (such as for airplanes, aerospace, automotive equipment, traffic signaling equipment, combustion equipment, life support systems and safety devices) in which exceptional quality and reliability are required, or if the failure or malfunction of the products may directly jeopardize life or harm the human body.
 It is to be understood that our company shall not be held responsible for any damage incurred as a result of or in connection with your using the products described in this book for any special application, unless our company agrees to your using the products in this book for any special application.
- (4) The products and product specifications described in this book are subject to change without notice for modification and/or improvement. At the final stage of your design, purchasing, or use of the products, therefore, ask for the most up-to-date Product Standards in advance to make sure that the latest specifications satisfy your requirements.
- (5) When designing your equipment, comply with the range of absolute maximum rating and the guaranteed operating conditions (operating power supply voltage and operating environment etc.). Especially, please be careful not to exceed the range of absolute maximum rating on the transient state, such as power-on, power-off and mode-switching. Otherwise, we will not be liable for any defect which may arise later in your equipment.  
Even when the products are used within the guaranteed values, take into the consideration of incidence of break down and failure mode, possible to occur to semiconductor products. Measures on the systems such as redundant design, arresting the spread of fire or preventing glitch are recommended in order to prevent physical injury, fire, social damages, for example, by using the products.
- (6) Comply with the instructions for use in order to prevent breakdown and characteristics change due to external factors (ESD, EOS, thermal stress and mechanical stress) at the time of handling, mounting or at customer's process. When using products for which damp-proof packing is required, satisfy the conditions, such as shelf life and the elapsed time since first opening the packages.
- (7) This book may be not reprinted or reproduced whether wholly or partially, without the prior written permission of our company.

### Precautions on the Sales of IPDs

- 1) The sale and/or the export of IPD products to customers located in certain countries is restricted by the Agreement made and executed by and between Power Integrations, Inc. and Panasonic Corporation. For details, refer to the following Attached table "IPD availability by customer."
- 2) IPD products purchased from our company, or its authorized agents, hereinafter referred to as our company, shall be used only for production purposes by those parties who have duly purchased IPD products. Those who have purchased IPD products shall not use such IPD products in unmodified form for re-sale, loan, or sample shipment for evaluation purposes to any other parties.
- 3) If a party who has duly purchased IPD products subcontracts its production to any other parties, including its subsidiaries or any other third parties inside and/or out of Japan, and the IPD products are consigned to such subcontracting parties thereat, such party is obligated to monitor and control the quantity of IPD products to prevent any of the aforementioned re-sale, loan or sample shipments from taking place.
- 4) In the event that any actual or threatened breach or violation of any of the above mentioned 2) or 3) has occurred or is about to occur, our company will hold all shipments of IPD products and may request the customer to disclose necessary documentation describing the status of our end-users and/or distribution channels.

Note) The products of MIP50\*\*, MIP51\*\*, and MIP7\*\* are excluded from above-mentioned precautions, 1) to 3).

Attached table "IPD availability by customer"

Parts No.			Companies/areas to which products can be sold	Companies/areas to which products cannot be sold	Application
MIP01** MIP2** MIP9A**	MIP02** MIP3** MIP9L**	MIP1** MIP4**	<ul style="list-style-type: none"> <li>· Japanese companies in Japan</li> <li>· Japanese companies in Asia (50% or more owned)</li> </ul>	<ul style="list-style-type: none"> <li>· Companies in European and American countries</li> <li>· Asian companies in Asia</li> <li>· Other local companies</li> </ul>	<ul style="list-style-type: none"> <li>· For power supply</li> <li>· For DC-DC converter</li> </ul>
MIP00** MIP55** MIP803/804	MIP52** MIP56** MIP816/826	MIP53** MIP5S** MIP9E**	<ul style="list-style-type: none"> <li>· Japanese companies in Japan</li> <li>· Japanese companies in Asia (50% or more owned)</li> <li>· Asian companies in Asia</li> </ul>	<ul style="list-style-type: none"> <li>· Companies in European and American countries</li> <li>· Other local companies</li> </ul>	<ul style="list-style-type: none"> <li>· For power supply</li> <li>· For EL driver</li> <li>· For LED lighting driver</li> </ul>
MIP50**	MIP51**	MIP7**	<ul style="list-style-type: none"> <li>· No restrictions in terms of contract</li> </ul>	<ul style="list-style-type: none"> <li>· No restrictions in terms of contract</li> </ul>	<ul style="list-style-type: none"> <li>· For lamp driver/ car electronics accessories</li> </ul>

Note) For details, contact our sales division.