

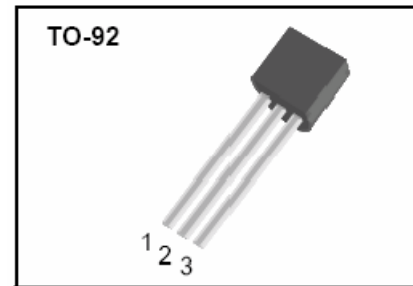
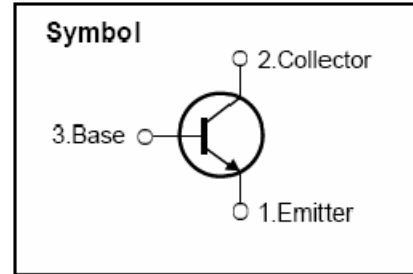
## High Voltage Fast-Switching NPN Power Transistor

### Features

- ◆ Very High Switching Speed
- ◆ High Voltage Capability
- ◆ Wide Reverse Bias SOA

### General Description

This Device is designed for high voltage, High speed switching characteristics required such as lighting system, switching mode power supply.



### Absolute Maximum Ratings

Symbol	Parameter	Test Conditions	Value	Units
$V_{CES}$	Collector-Emitter Voltage	$V_{BE} = 0$	600	V
$V_{CEO}$	Collector-Emitter Voltage	$I_B = 0$	400	V
$V_{EBO}$	Emitter-Base Voltage	$I_C = 0$	9.0	V
$I_C$	Collector Current		1.25	A
$I_{CP}$	Collector pulse Current		2.5	A
$I_B$	Base Current		-	A
$I_{BM}$	Base Peak Current	$t_p = 5ms$	-	A
$P_C$	Total Dissipation at $T_c = 25^\circ C$		12	W
	Total Dissipation at $T_a = 25^\circ C$		0.8	
$T_J$	Operation Junction Temperature		- 40 ~ 150	$^\circ C$
$T_{STG}$	Storage Temperature		- 40 ~ 150	$^\circ C$

$T_c$ : Case temperature (good cooling)

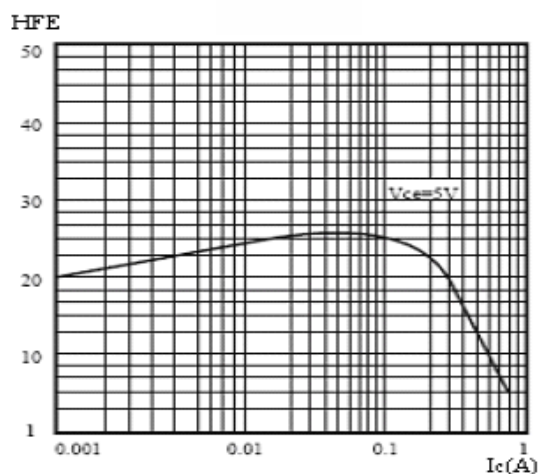
$T_a$ : Ambient temperature (without heat sink)

**Electrical Characteristics** ( $T_c=25^\circ\text{C}$  unless otherwise noted)

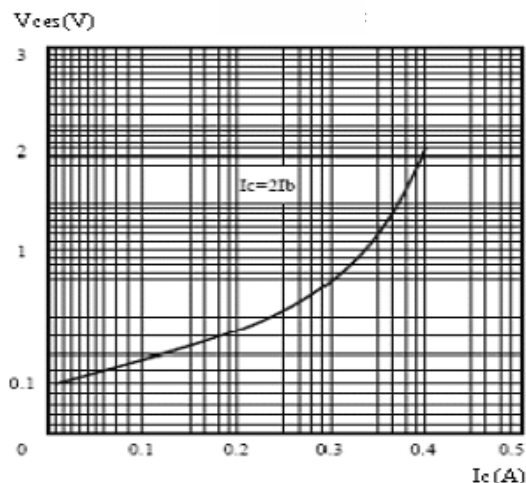
Symbol	Parameter	Test Conditions	Value			Units
			Min	Typ	Max	
$BV_{CBO}$	Collector-Base Breakdown Voltage	$I_c=0.5\text{mA}, I_e=0$	600			V
$BV_{CEO}$	Collector-Emitter Breakdown Voltage	$I_c=10\text{mA}, I_b=0$	400	-	-	V
$V_{CE(sat)}$	Collector-Emitter Saturation Voltage	$I_c=200\text{mA}, I_b=100\text{mA}$	-	-	1.6	V
$V_{BE(sat)}$	Base-Emitter Saturation Voltage	$I_c=200\text{mA}, I_b=100\text{mA}$	-	-	1.2	V
$I_{CBO}$	Collector-Base Cutoff Current	$V_{cb}=550\text{V}, I_e=0\text{mA}$	-	-	10	$\mu\text{A}$
$I_{CEO}$	Collector-Emitter Cutoff Current	$V_{ce}=400\text{V}, I_b=0\text{mA}$	-	-	20	$\mu\text{A}$
$I_{EBO}$	Emitter- Base Cutoff Current	$V_{eb}=9\text{V}, I_c=0\text{mA}$	-	-	20	$\mu\text{A}$
$h_{FE}$	DC Current Gain	$V_{ce}=20\text{V}, I_c=20\text{mA}$ $V_{ce}=5\text{V}, I_c=1\text{mA}$	10 9		40	
$t_s$	Storage Time	$V_{CC}=250\text{V}$	2	-	-	$\mu\text{s}$
$t_f$	Fall Time	$I_C=5 I_B$ $I_{B1}=- I_{B2}=0.04\text{A}$	-	-	0.8	

**Note:**

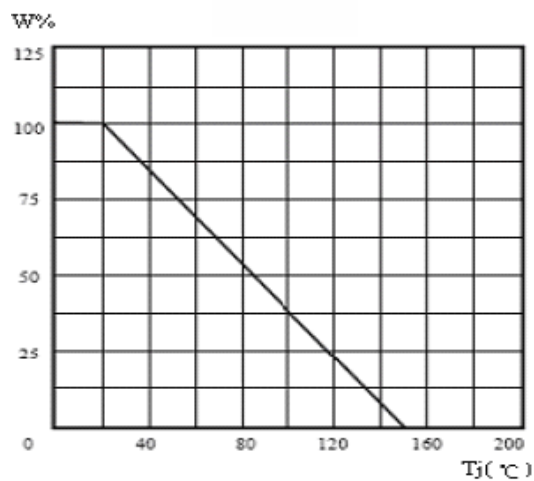
Pulse Test : Pulse width 300, Duty cycle 2%



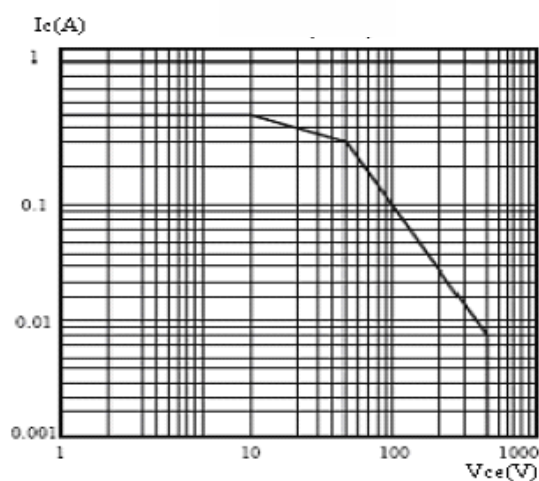
**Fig. 1 DC Current Gain**



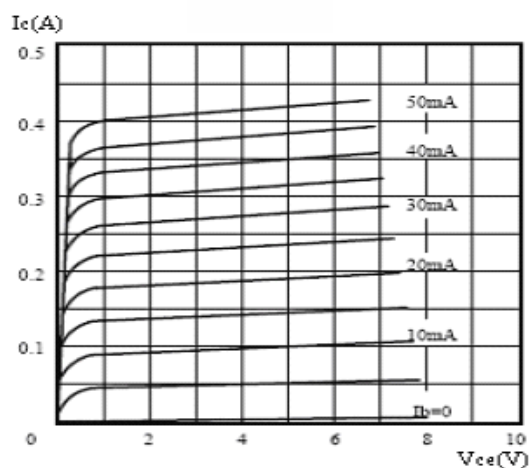
**Fig. 2 Saturation Voltage**



**Fig. 3 Power Derating**

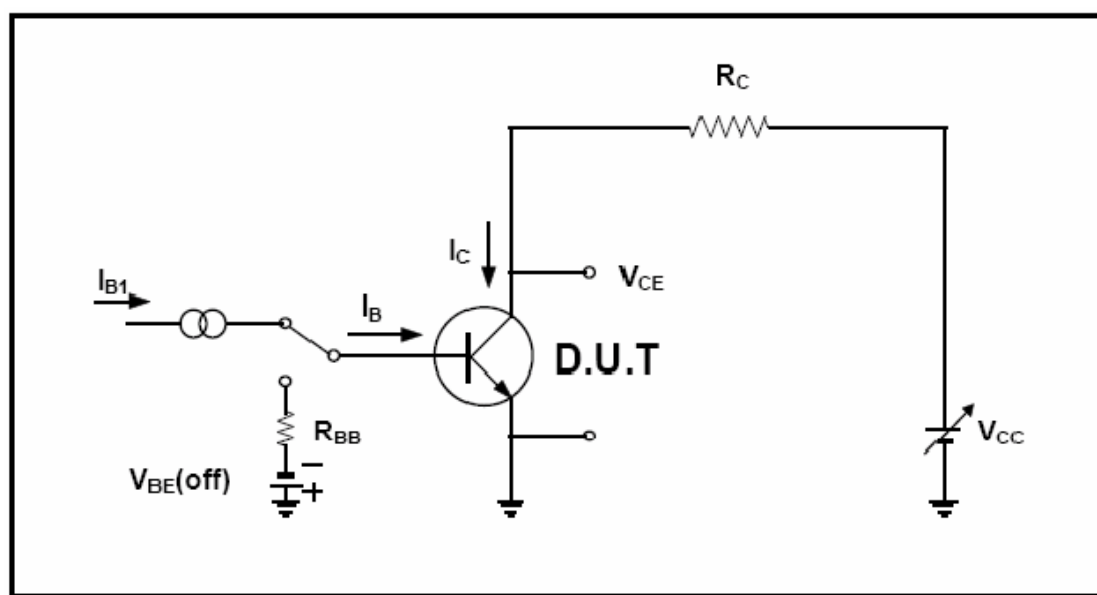


**Fig. 4 Safe Operation Area**

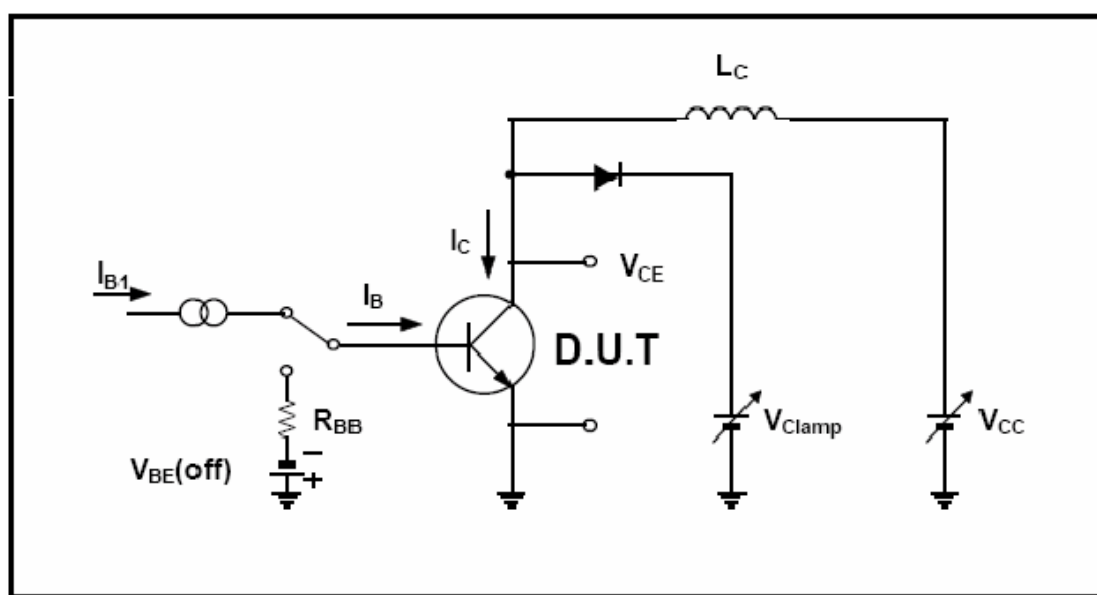


**Fig. 5 Static Characteristics**

### Resistive Load Switching Test Circuit

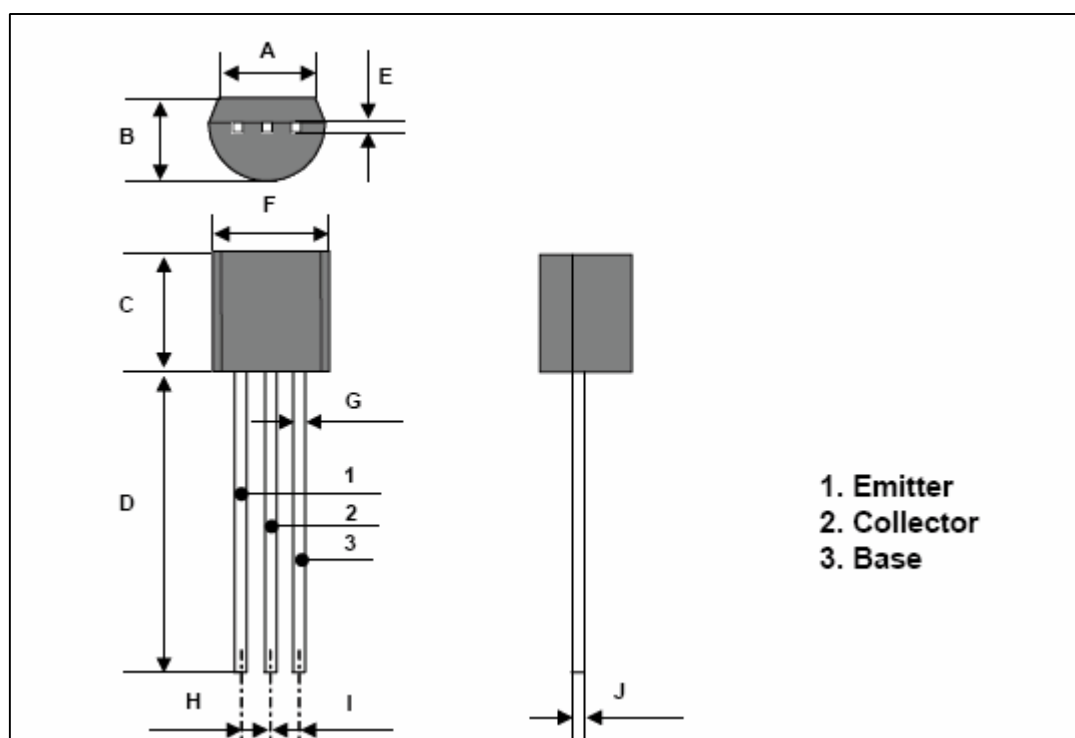


### Inductive Load Switching & RBSOA Test Circuit



## TO-92 Package Dimension

Dim.	mm			Inch		
	Min.	Typ.	Max.	Min.	Typ.	Max.
A		4.2			0.165	
B			3.7			0.146
C	4.43		4.83	0.174		0.190
D	14.07		14.87	0.554		0.585
E			0.4			0.016
F	4.43		4.83	0.174		0.190
G			0.45			0.017
H		1.27			0.050	
I		1.27			0.050	
J	0.33		0.48	0.013		0.019



## CONTACT US

### Headquarters

A Building Caohejing I&E Park  
Pujiang Minhang Shanghai  
China

### Web

<http://www.semiwill.com>

### By Telephone

General: 86-21-34637654  
Sales: 86-21-34637458  
Customer Service: 86-21-34637172

### By Email

Sales: [sales@semiwill.com](mailto:sales@semiwill.com)  
Customer Service: [cs@semiwill.com](mailto:cs@semiwill.com)  
Technical Support: [fae@semiwill.com](mailto:fae@semiwill.com)

### By Fax

General: 86-21-34637173  
Sales: 86-21-39650654

COPYRIGHT ©SEMIWILL 2009 - This literature is subject to all applicable copyright laws and is not for resale in any manner.

SPECIFICATIONS: SEMIWILL reserves the right to change the electrical and or mechanical characteristics described herein without notice.

DESIGN CHANGES: SEMIWILL reserves the right to discontinue product lines without notice and that the final judgement concerning selection and specifications is the buyer's and that in furnishing engineering and technical assistance. SEMIWILL assumes no responsibility with respect to the selection or specifications of such products. SEMIWILL makes no warranty, representation or guarantee regarding the suitability of its products for any particular purpose, nor does SEMIWILL assume any liability arising out of the application or use of any product or circuit and specifically disclaims any and all liability without limitation special, consequential or incidental damages.

LIFE SUPPORT POLICY: SEMIWILL products are not authorized for use in life support systems without written consent from the factory.