



NPN POWER TRANSISTORS

MJE13006

300 VOLTS
8 AMP, 80 WATTS

Designed for switching regulator, DC-DC converter, AC-DC inverter, high voltage, high speed switching applications.

Features:

- $V_{CE0(sus)} = 300V$ (Min).
- $V_{CEV} = 600V$ blocking capability
- Excellent switching time: $t_r = 1.5 \mu s$ (Max.),
 $t_f = 0.7 \mu s$ (Max.)

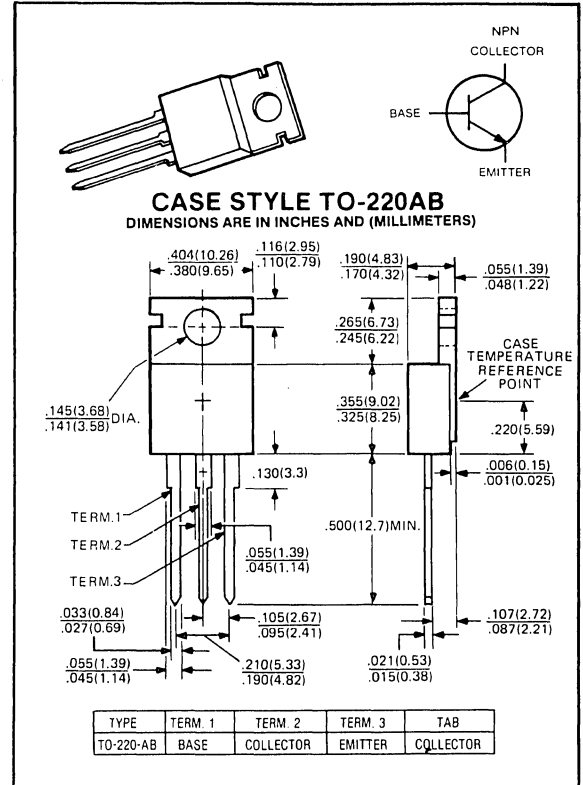

maximum ratings ($T_A = 25^\circ C$) (unless otherwise specified)

RATING	SYMBOL	MJE13006	UNITS
Collector-Emitter Voltage	V_{CE0}	300	Volts
Collector-Emitter Voltage	V_{CEV}	600	Volts
Emitter Base Voltage	V_{EBO}	9	Volts
Collector Current — Continuous	I_C	8	A
Collector Current — Pulse	I_{CP}	16	A
Base Current — Continuous	I_B	4	A
Base Current — Pulse	I_{BP}	8	A
Emitter Current — Continuous	I_E	12	A
Emitter Current — Pulse	I_{EP}	24	A
Collector Power Dissipation Derate above 25°C	P_C	2 16	Watts mW/°C
Collector Power Dissipation Derate above 25°C	P_C	80 640	Watts mW/°C
Operating and Storage Junction Temperature Range	T_J, T_{STG}	-65 to +150	°C

thermal characteristics

Thermal Resistance, Junction to Case	$R_{\theta JC}$	1.56	$^{\circ}\text{C/W}$
Thermal Resistance, Junction to Ambient	$R_{\theta JA}$	62.5	$^{\circ}\text{C/W}$
Maximum Lead Temperature for Soldering Purpose: $\frac{1}{8}$ " from Case for 5 Seconds	T_L	275	$^{\circ}\text{C}$

electrical characteristics ($T_C = 25^{\circ}\text{C}$) (unless otherwise specified)

CHARACTERISTIC	SYMBOL	MIN	TYP	MAX	UNIT
----------------	--------	-----	-----	-----	------

off characteristics⁽¹⁾

Collector-Emitter Voltage ($I_C = 10\text{mA}$, $I_B = 0$)	$V_{CEO(sus)}$	300	—	—	Volts
Collector Cutoff Current ($V_{CE} = 600\text{V}$, $V_{BE} = -1.5\text{V}$) ($V_{CE} = 600\text{V}$, $V_{BE} = -1.5\text{V}$, $T_C = 100^{\circ}\text{C}$)	I_{CEV}	—	—	1 5	mA
Emitter Cutoff Current ($V_{EB} = 9\text{V}$, $I_C = 0$)	I_{EBO}	—	—	1	mA

second breakdown

Second Breakdown with Base Forward Biased	FBSOA	SEE FIGURE 1
Clamped Inductive SOA with Base Reversed Bias	RBSOA	SEE FIGURE 2

on characteristics⁽¹⁾

DC Current Gain ($I_C = 2\text{A}$, $V_{CE} = 5\text{V}$) ($I_C = 5\text{A}$, $V_{CE} = 5\text{V}$)	h_{FE}	8 5	— —	60 30	—
Collector-Emitter Saturation Voltage ($I_C = 2\text{A}$, $I_B = 0.4\text{A}$) ($I_C = 5\text{A}$, $I_B = 1\text{A}$) ($I_C = 8\text{A}$, $I_B = 2\text{A}$) ($I_C = 5\text{A}$, $I_B = 1\text{A}$, $T_C = 100^{\circ}\text{C}$)	$V_{CE(sat)}$	— — — —	— — — —	1 2 3 3	V
Base-Emitter Saturation Voltage ($I_C = 2\text{A}$, $I_B = 0.4\text{A}$) ($I_C = 5\text{A}$, $I_B = 1\text{A}$) ($I_C = 5\text{A}$, $I_B = 1\text{A}$, $T_C = 100^{\circ}\text{C}$)	$V_{BE(sat)}$	— — —	— — —	1.2 1.6 1.5	V

dynamic characteristics

Output Capacitance ($V_{CB} = 10\text{V}$, $I_E = 0$, $f = 0.1\text{MHz}$)	C_{ob}	—	90	—	pF
Current Gain — Bandwidth Product ($I_C = 500\text{mA}$, $V_{CE} = 10\text{V}$, $f_{test} = 1.0\text{MHz}$)	f_T	4	—	—	MHz

switching characteristics

Resistive Load						
Delay Time	$(V_{CC} = 125\text{V}$, $I_C = 5\text{A}$ $I_{B1} = -I_{B2} = 1\text{A}$, $t_p = 25\mu\text{s}$ Duty Cycle < 1%)	t_d	—	—	0.1	μs
Rise Time		t_r	—	—	1.5	
Storage Time		t_s	—	—	3	
Fall Time		t_f	—	—	0.7	
Inductive Load, Clamped						
Storage Time	Inductive Load ($I_C = 5\text{A}$, $V_{clamp} = 300\text{V}$, $I_{B1} = 1\text{A}$, $V_{BE(off)} = -5\text{V}$, $T_C = 100^{\circ}\text{C}$)	t_{sv}	—	—	2.3	μs
Crossover Time		t_c	—	—	0.7	

(1) Pulse Test: Pulse Width - $300\mu\text{s}$ Duty Cycle $\leq 2\%$.

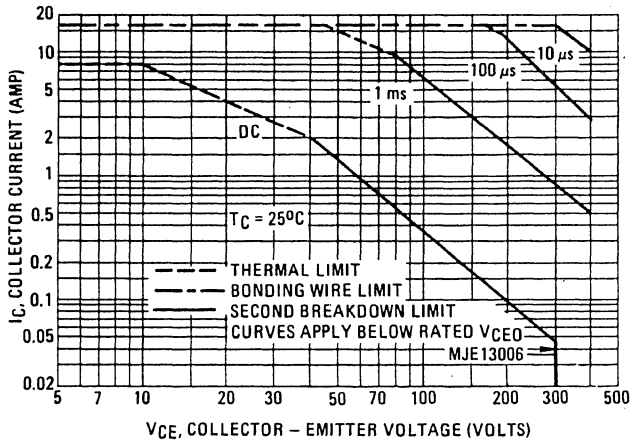

FIGURE 1 – FORWARD BIAS SAFE OPERATING AREA

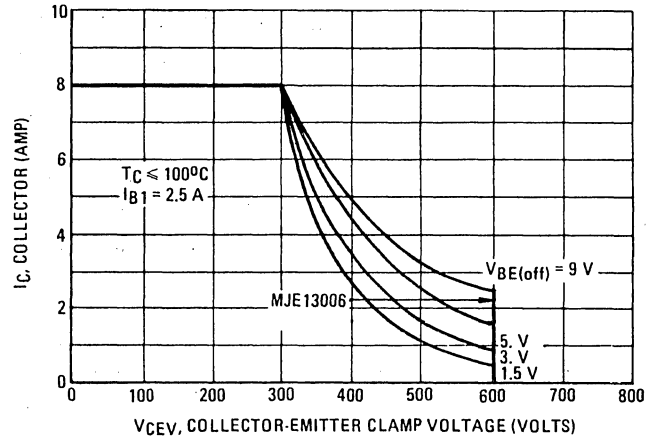

FIGURE 2 – REVERSE BIAS SWITCHING SAFE OPERATING AREA

The Safe Operating Area figures shown in Figures 1 and 2 are specified ratings for these devices under the test conditions shown.

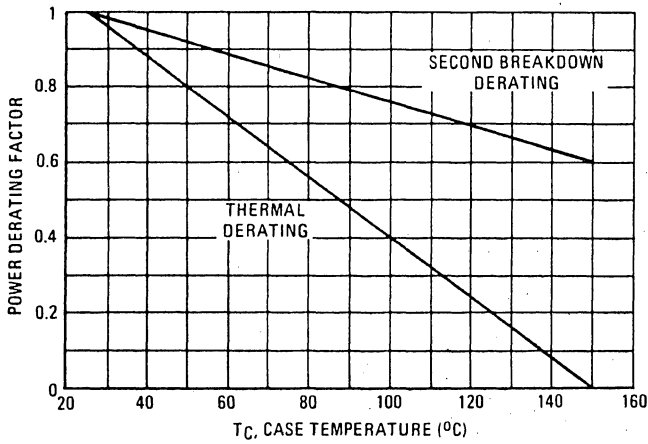

FIGURE 3 – FORWARD BIAS POWER DERATING

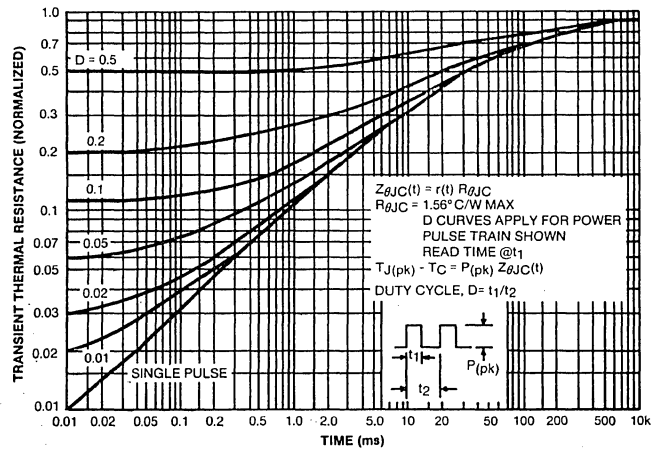

FIGURE 4 TYPICAL THERMAL RESPONSE $[(Z_{\theta JC}(t))]$

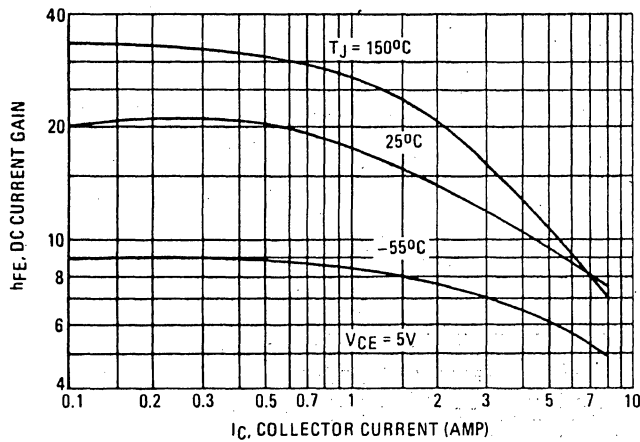

FIGURE 5 – DC CURRENT GAIN

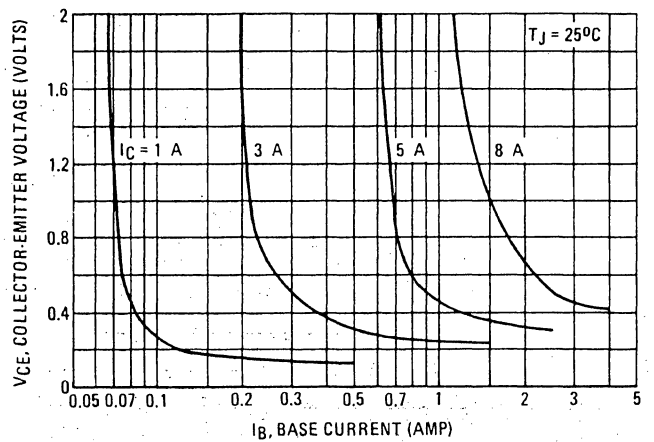

FIGURE 6 – COLLECTOR SATURATION REGION

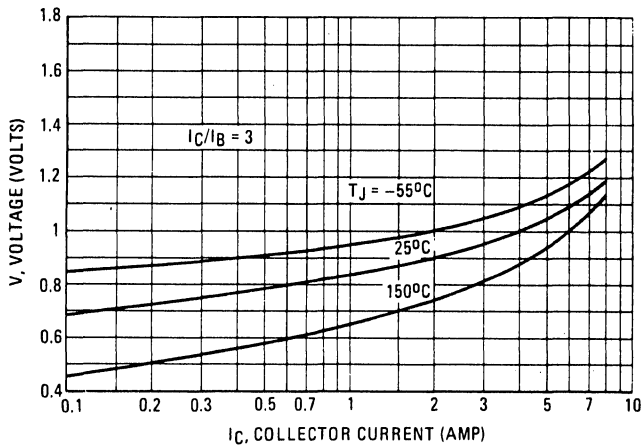

FIGURE 7 – BASE-EMITTER SATURATION VOLTAGE

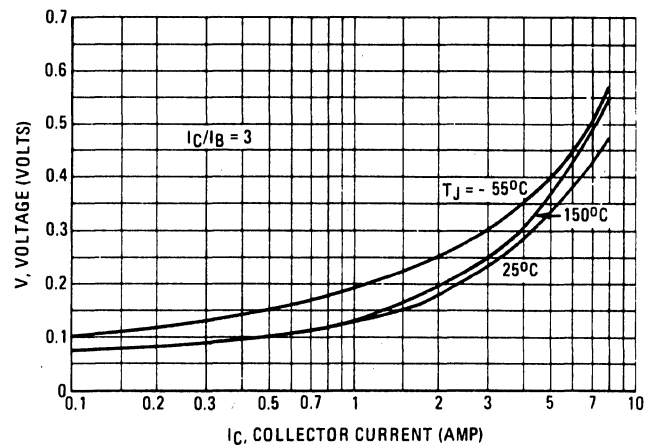

FIGURE 8 – COLLECTOR-EMITTER SATURATION VOLTAGE

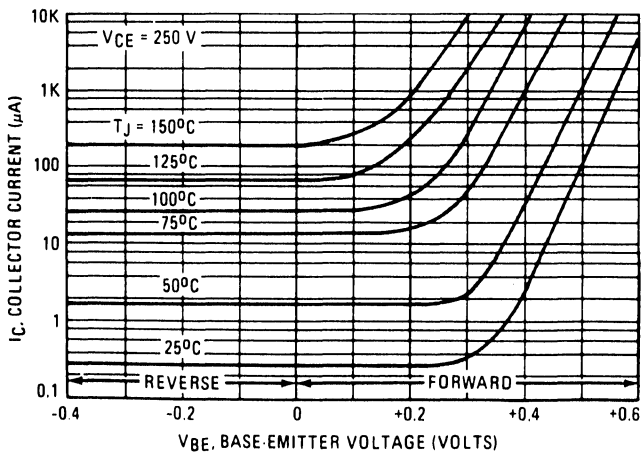

FIGURE 9 – COLLECTOR CUTOFF REGION

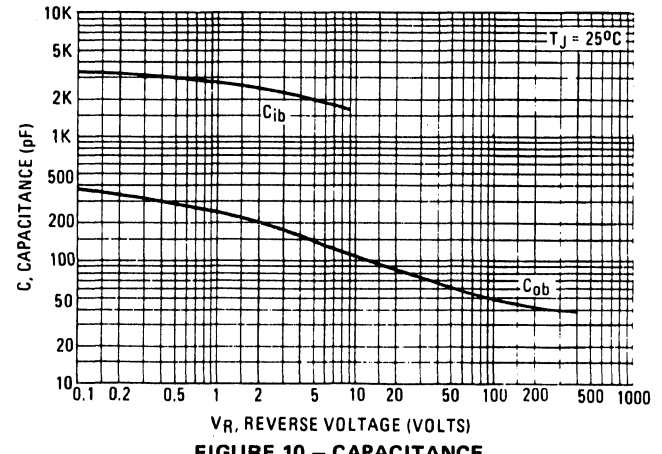

FIGURE 10 – CAPACITANCE

RESISTIVE SWITCHING PERFORMANCE

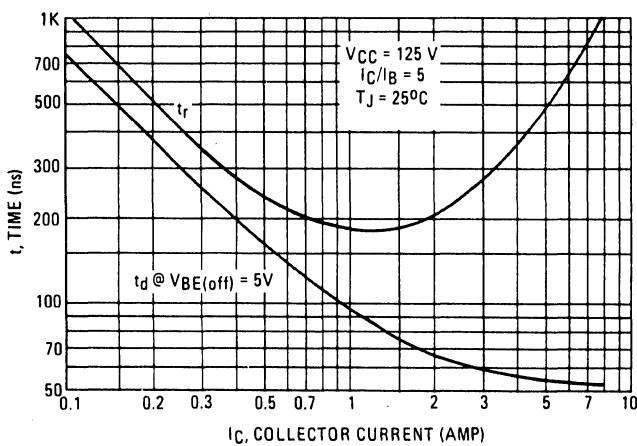

FIGURE 11 – TURN-ON TIME

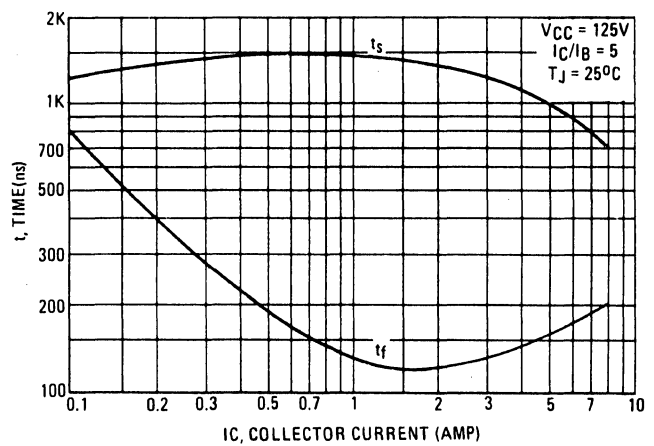

FIGURE 12 – TURN-OFF TIME

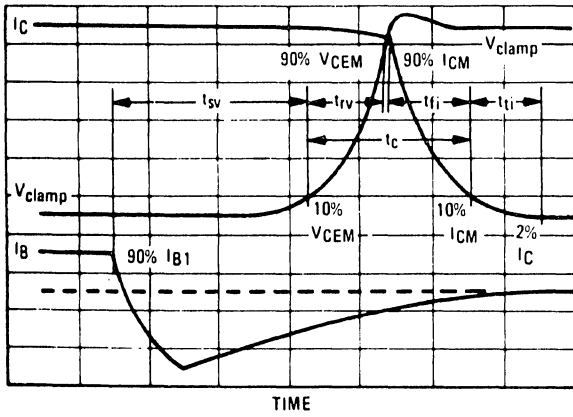

FIGURE 13 – INDUCTIVE SWITCHING MEASUREMENTS

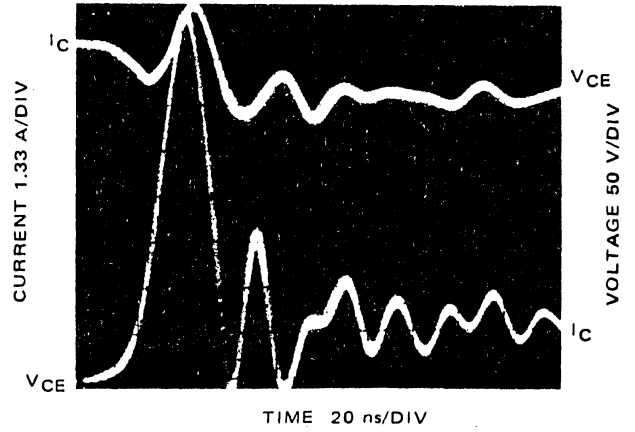

FIGURE 14 – TYPICAL INDUCTIVE SWITCHING WAVEFORMS
(at 300 V and 8A with $I_{B1} = 1.6A$ and $V_{BE(off)} = 5 V$)