

Silicon NPN Power Transistors

MJE1320

DESCRIPTION

www.datasheet4u.com

- With TO-220 package
- High voltage
- Low collector saturation voltage

APPLICATIONS

- For high-voltage ,power switching in inductive circuits and line operated switchmode applications

PINNING

PIN	DESCRIPTION
1	Base
2	Collector
3	Emitter

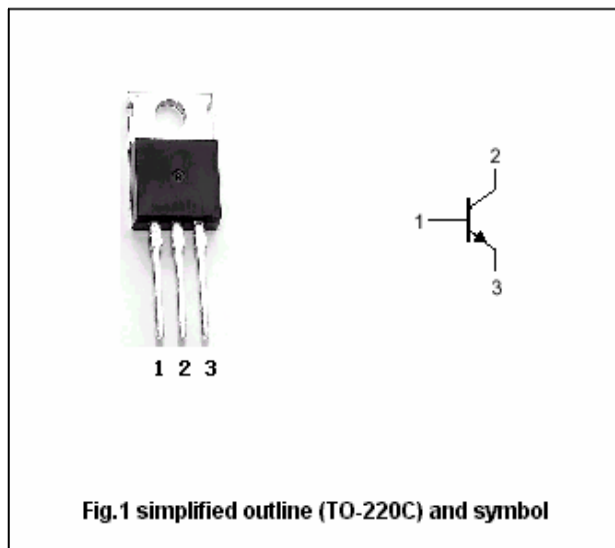
Absolute maximum ratings($T_c=25^\circ\text{C}$)

SYMBOL	PARAMETER	CONDITIONS	VALUE	UNIT
V_{CBO}	Collector-base voltage	Open emitter	1800	V
V_{CEO}	Collector-emitter voltage	Open base	900	V
V_{EBO}	Emitter-base voltage	Open collector	9	V
I_C	Collector current		2	A
I_{CM}	Collector current-Peak		5	A
I_B	Base current		1.5	A
I_{BM}	Base current-Peak		2.5	A
P_D	Total power dissipation	$T_c=25^\circ\text{C}$ $T_c=100^\circ\text{C}$	80 32	W
T_j	Junction temperature		-65~150	$^\circ\text{C}$
T_{stg}	Storage temperature		-65~150	$^\circ\text{C}$

THERMAL CHARACTERISTICS

SYMBOL	PARAMETER	MAX	UNIT
R_{thj-c}	Thermal resistance junction to case	1.56	$^\circ\text{C}/\text{W}$

Silicon NPN Power Transistors

MJE1320

CHARACTERISTICS

T_j=25°C unless otherwise specified

www.datasheet4u.com

SYMBOL	PARAMETER	CONDITIONS	MIN	TYP.	MAX	UNIT
V _{CE0(SUS)}	Collector-emitter sustaining voltage	I _C =50mA; I _B =0.	900			V
V _{CE(sat)-1}	Collector-emitter saturation voltage	I _C =1A; I _B =0.5A T _C =100°C		0.18 0.3	1.0 1.5	V
V _{CE(sat)-2}	Collector-emitter saturation voltage	I _C =2A; I _B =1A		0.3	2.5	V
V _{BE(sat)-1}	Base-emitter saturation voltage	I _C =1A; I _B =0.5A T _C =100°C		0.2 0.15	1.5 1.5	V
V _{BE(sat)-2}	Base-emitter saturation voltage	I _C =2A; I _B =1A		0.9	2.8	V
I _{CEV}	Collector cut-off current	V _{CEV} =RatedV _{alue} ; V _{BE(off)} =1.5V T _C =100°C			0.25 2.5	mA
I _{EBO}	Emitter cut-off current	V _{EB} =9V; I _C =0			0.25	mA
h _{FE-1}	DC current gain	I _C =2A; V _{CE} =5V	2.5			
h _{FE-2}	DC current gain	I _C =1A; V _{CE} =5V	3			
C _{OB}	Collector outoput capacitance	I _E =0; V _{CB} =10V; f=1.0MHz		80		pF

Switching times resistive load, Duty Cycle ≤ 2%, t_p=25μs

t _d	Delay time	V _{CC} =250V; I _C =1A I _{B1} =I _{B2} =0.5A		0.1		μs
t _r	Rise time			0.8		μs
t _s	Storage time			4.0		μs
t _f	Fall time			0.8		μs

PACKAGE OUTLINE

www.datasheet4u.com

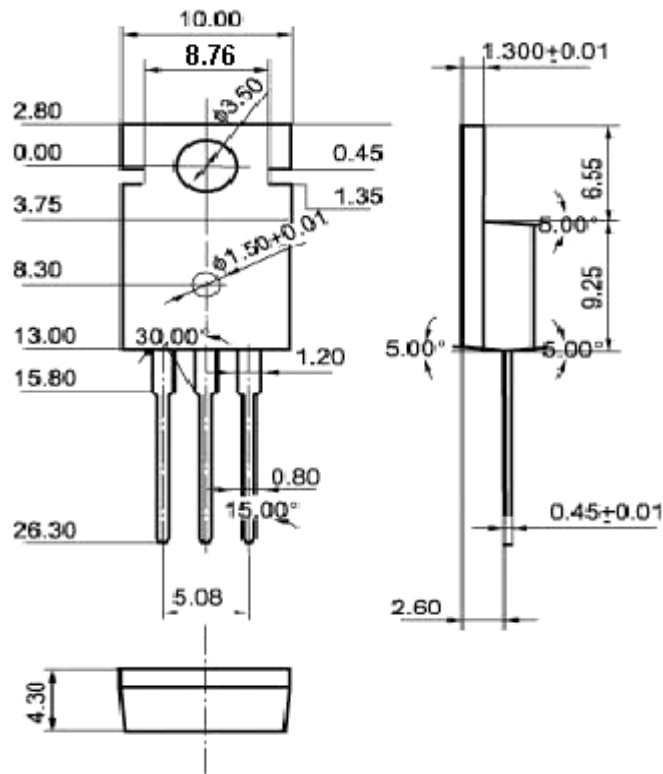

Fig.2 Outline dimensions (unindicated tolerance: ± 0.10 mm)