

Silicon NPN Power Transistors

MJF18004

DESCRIPTION

With TO-220F package

High voltage ,high speed

APPLICATIONS

Designed for use in 220V line-operated
switchmode power supplies and electronic
light ballasts

PINNING

PIN	DESCRIPTION
1	Base
2	Collector
3	Emitter

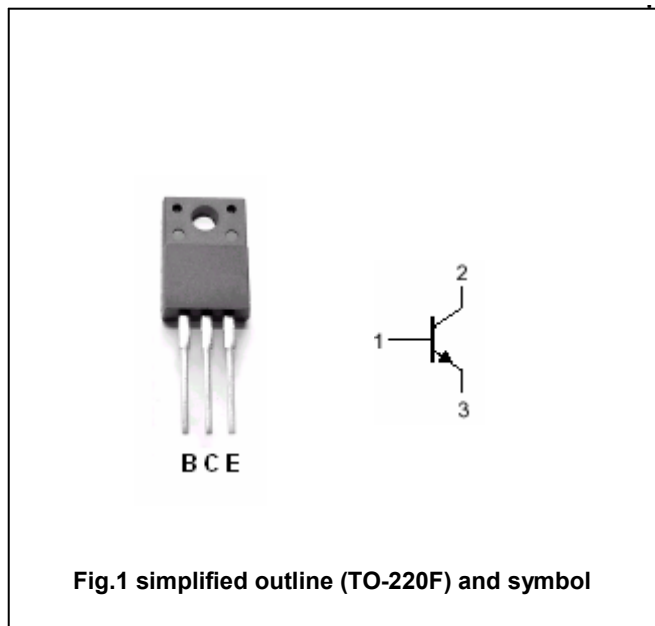
ABSOLUTE MAXIMUM RATINGS($T_c=25^\circ\text{C}$)

SYMBOL	PARAMETER	CONDITIONS	VALUE	UNIT
V_{CBO}	Collector-base voltage	Open emitter	1000	V
V_{CEO}	Collector-emitter voltage	Open base	450	V
V_{EBO}	Emitter-base voltage	Open collector	9	V
I_C	Collector current (DC)		5	A
I_{CM}	Collector current-Peak		10	A
I_B	Base current		2	A
I_{BM}	Base current-Peak		4	A
P_D	Total power dissipation	$T_c=25^\circ\text{C}$	40	W
T_j	Junction temperature		150	$^\circ\text{C}$
T_{stg}	Storage temperature		-65~150	$^\circ\text{C}$

THERMAL CHARACTERISTICS

SYMBOL	PARAMETER	MAX	UNIT
$R_{th\ j-C}$	Thermal resistance junction to case	3.12	$^\circ\text{C}/\text{W}$
$R_{th\ j-A}$	Thermal resistance junction to ambient	62.5	$^\circ\text{C}/\text{W}$

Silicon NPN Power Transistors

MJF18004

CHARACTERISTICS

T_j=25°C unless otherwise specified

www.datasheet4u.com

SYMBOL	PARAMETER	CONDITIONS	MIN	TYP.	MAX	UNIT
V _{CEQ(SUS)}	Collector-emitter sustaining voltage	I _C =0.1A; L=25mH	450			V
V _{CE(sat)-1}	Collector-emitter saturation voltage	I _C =1A; I _B =0.1A T _C =125°C			0.5 0.6	V
V _{CE(sat)-2}	Collector-emitter saturation voltage	I _C =2A; I _B =0.4A T _C =125°C			0.45 0.8	V
V _{CE(sat)-3}	Collector-emitter saturation voltage	I _C =2.5A; I _B =0.5A			0.75	V
V _{BE(sat)-1}	Base-emitter saturation voltage	I _C =1A; I _B =0.1A			1.1	V
V _{BE(sat)-2}	Base-emitter saturation voltage	I _C =2A; I _B =0.4A			1.25	V
V _{BE(sat)-3}	Base-emitter saturation voltage	I _C =2.5A; I _B =0.5A			1.3	V
I _{CES}	Collector cut-off current	V _{CE} =RatedV _{CE} ; V _{EB} =0	T _C =125°C		0.1	mA
					0.5	
		V _{CE} =800V			0.1	
I _{CEO}	Collector cut-off current	V _{CE} =RatedV _{CE} ; I _B =0			0.1	mA
I _{EBO}	Emitter cut-off current	V _{EB} =9V; I _C =0			0.1	mA
h _{FE-1}	DC current gain	I _C =1A; V _{CE} =2.5V	12			
h _{FE-2}	DC current gain	I _C =1A; V _{CE} =5V	14		36	
h _{FE-3}	DC current gain	I _C =2A; V _{CE} =1V	6			
h _{FE-4}	DC current gain	I _C =5mA; V _{CE} =5V	10			
f _T	Transition frequency	I _C =0.5A; V _{CE} =10V; f=1.0MHz		13		MHz
C _{OB}	Collector output capacitance	I _E =0; V _{CB} =10V; f=1.0MHz		45		pF

Switching times resistive load, Duty Cycle≤10%, Pulse Width=20μs

t _{on}	Turn-on time	V _{CC} =250V, I _C =2.5A I _{B1} =0.5A; I _{B2} =0.5A			0.6	μs
t _s	Storage time				3.0	μs
t _f	Fall time				0.4	μs

Silicon NPN Power Transistors

MJF18004

PACKAGE OUTLINE

www.datasheet4u.com

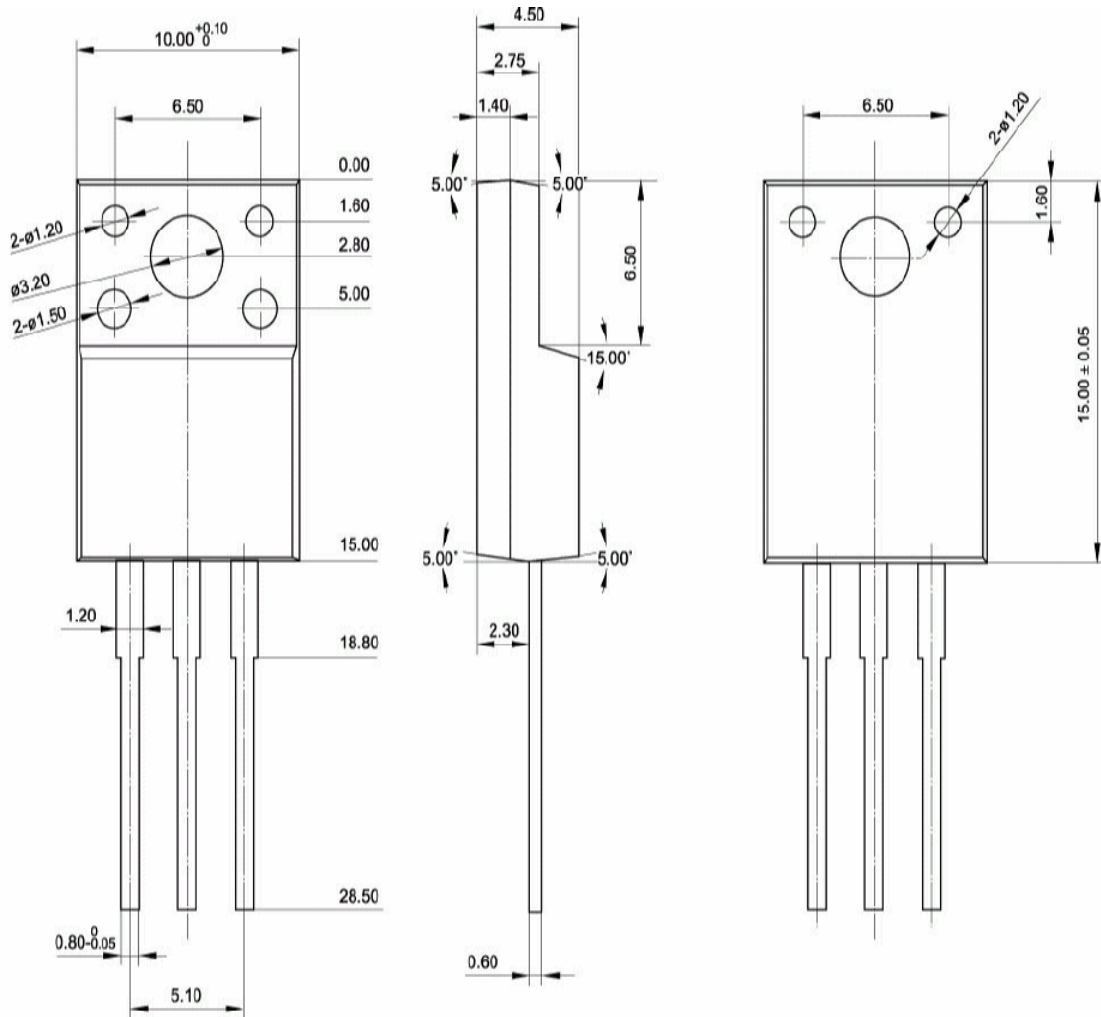

Fig.2 Outline dimensions