

SYNCHRONOUS RECTIFICATION SWITCHER SUPPORTING CCM

1. Description

The MK1283 is a compact secondary side synchronous rectification switcher which integrated controller and MOSFET for high performance flyback converters. It is compatible with CCM, DCM and QR operations.

The MK1283 can generate its own supply voltage while with high-side rectification; this eliminates the need of auxiliary winding of the transformer, which is usually required to produce supply voltage.

The extremely low 10ns turn-off propagation delay time and high sink current (~4A) capability of the driver improve SR VDS stress at CCM mode.

2. Typical Applications

- AC/DC Adapters for Mobile Phone and Notebook
- High Power density AC/DC Power Supplies
- Battery Powered System

4. Simplified Application

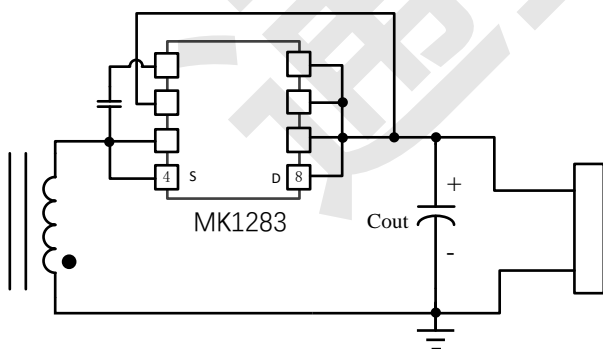

Used in high side rectification

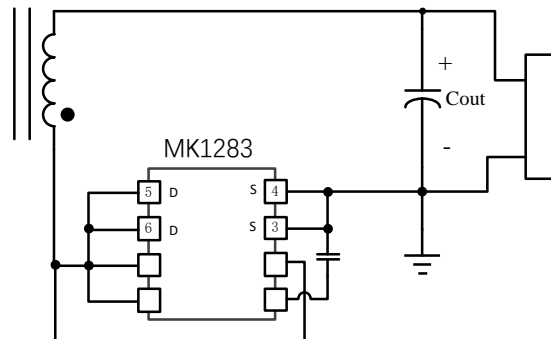

Used in low side rectification

3. Features

- Integrated 15mΩ 85V Power MOSFET
- Operates in a wide output voltage range down to 3V voltage (self-supply)
- Self-supply for operations with low-side rectification and high-side rectification without an auxiliary winding
- 10ns Fast Turn-off and 25ns Turn-on Delay
- VG Clamping Circuit Works Well when VCC is Below 2V
- Supports CCM, DCM and QR Operations
- Precise 0V turn off for maximum efficiency
- Designed for <200kHz working frequency
- Available in SOP-8 Package

5. Ordering Information

Ordering No.	Description	Material
MK1283CAB	SOP-8, MSL-3, 4000 pcs/reel	Halogen free

6. Package Reference

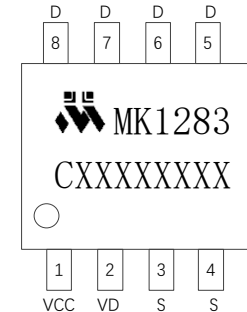

XXXXXXXX: Lot code
 MK1283CAB
 SOP-8

6.1. Absolute Maximum Ratings ⁽¹⁾

VCC to S.....	-0.3V to +20V
D to S.....	-0.7V to 85V
VD to S.....	-1V to 115V
VD to S.....	-3V to 120V ⁽²⁾
Continuous drain current I _D	7A ⁽³⁾
Pulsed drain current I _{DM}	26A ⁽⁴⁾
Continuous Power Dissipation.2.5W (T _A = +25°C) ⁽⁵⁾	
Junction Temperature.....	150°C

6.2. Recommended Operation Conditions

VCC to S.....	.5V to 9.5V
D to S.....	-0.7V to 80V
Maximum Junction Temp. (T _J).....	+125°C

6.3. Thermal Resistance ⁽⁶⁾

	θ_{JA}	θ_{JC}
SOP-8.....	80	35 °C/W

Notes:

- (1) Exceeding these ratings may damage the device.
- (2) Repetitive pulse < 200ns
- (3) T_A=25°C; Calculated continuous current based on maximum allowable junction temperature
- (4) Repetitive rating: pulse width limited by maximum junction temperature
- (5) The maximum allowable power dissipation is a function of the maximum junction temperature T_J(MAX), the junction-to-ambient thermal resistance θ_{JA} , and the ambient temperature T_A. The maximum allowable continuous power dissipation at any ambient temperature is calculated by P_D(MAX)=(T_J(MAX)-T_A)/ θ_{JA} . Exceeding the maximum allowable power dissipation will cause excessive die temperature.
- (6) Measured on JESDSD51-7, 4 layers PCB

7. Electrical Characteristics

$T_A=25^{\circ}\text{C}$, unless otherwise noted.

Parameter	Symbol	Conditions	Min	Typ	Max	Units
INTERNAL MOS SECTION						
Internal MOS R_{dson}	R_{dson}	$V_{CC}=9.5\text{V}$, $I_d=1\text{A}$		15	20	$\text{m}\Omega$
Drain to Source Breakdown	$V_{DSS(BR)}$	$V_{CC}=V_D=0\text{V}$, $I_d=250\mu\text{A}$	85			V
SUPPLY MANAGEMENT SECTION						
VCC UVLO Rising	V_{CC_ON}		4.3	4.6	4.9	V
VCC UVLO Falling	V_{CC_OFF}		3.8	4	4.3	V
VCC UVLO Hysteresis	V_{CC_HYST}		0.25	0.6	0.75	V
VCC Regulation Voltage	V_{CC_REG}	$V_D=14\text{V}$	8.2	9.1	10	V
Operating Current	$I_{CC}^{(1)}$	$V_{CC}=6\text{V}$, $F_{sw}=100\text{kHz}$,	1.5	2.0	2.5	mA
Quiescent Current	$I_{q(VCC)}$	$V_{CC}=6.4\text{V}$, $F_{sw}=0\text{Hz}$		350	550	μA
MOSFET VOLTAGE SENSING						
V_D-V_{SS} Adjusting Voltage	V_{DS_REG}		-55	-40	-25	mV
Turn-On Threshold (V_D-V_{SS})	V_{ON_th}		-350	-300	-50	mV
Turn Off Threshold (V_D-V_{SS})	V_{OFF_th}			0	10	mV
Turn-On Propagation Delay	T_{D_on}			25	40	ns
Turn-Off Propagation Delay	T_{D_off}			10	15	ns
Turn On Blanking Time	T_{B_ON}	$C_{LOAD} = 2.2\text{nF}$	0.75	1.0	1.3	μs
Turn Off Blanking V_{DS} Threshold in T_{B_ON}	V_{B_OFF}			2		V
Turn Off Blanking Time	T_{OFF}		250	300	350	ns
GATE DRIVER						
V_G (Low)	V_{G_LOW}	$V_{CC}=6.4\text{V}$, $I_{LOAD}=0.1\text{A}$	0	0.2	0.4	V
V_G (High)	V_{G_HIGH}	$V_{CC}=6.4\text{V}$, $I_{LOAD}=0.1\text{A}$	$V_{CC}-0.6$	$V_{CC}-0.3$	V_{CC}	V

Note:

- (1) I_{CC} in the table is the current consumed by the internal controller when 2.2nF load capacitance and 100kHz operating frequency.

8. Pin Functions

Pin #	Name	Description
1	VCC	Inner Regulator Output, supply MK1283
2	VD	FET drain voltage sense; HV pulse LDO input
3,4	S	Ground
5,6,7,8	D	FET drain

9. Block Diagram

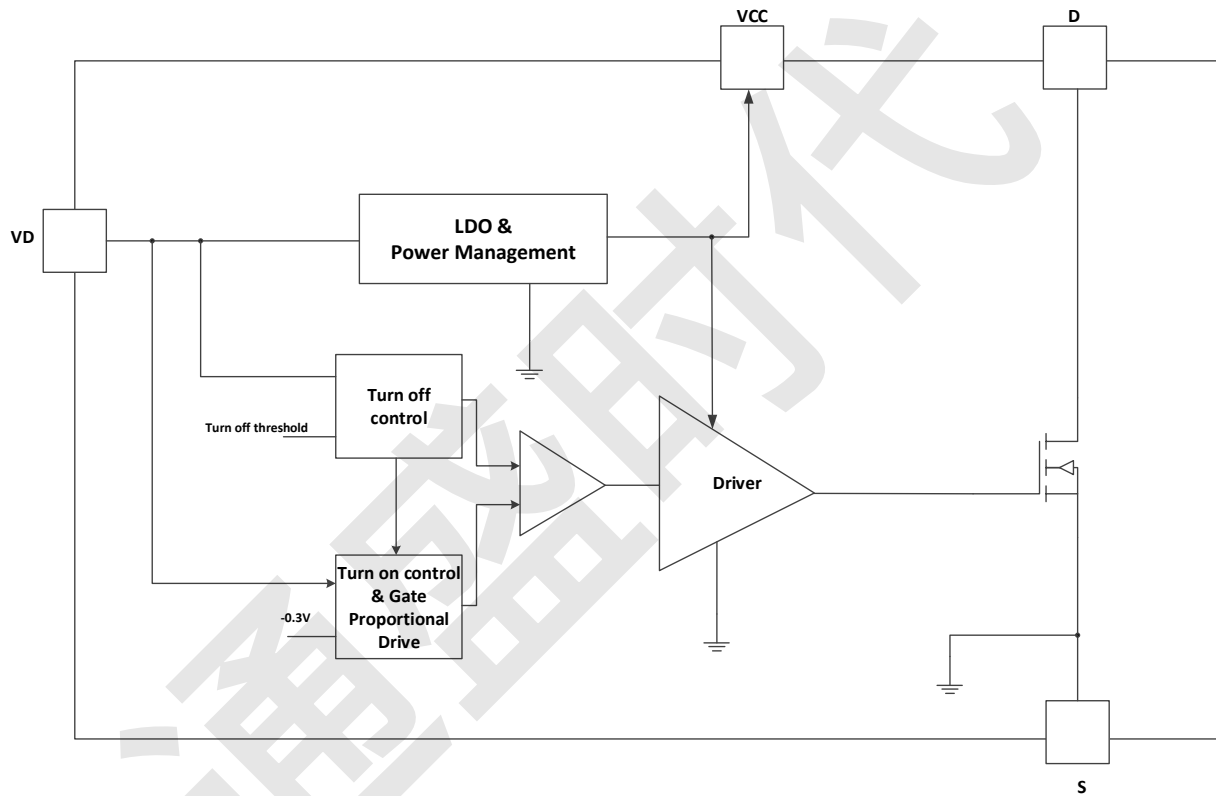

Figure 1. Functional Block Diagram

10. Operation Descriptions

MK1283 is a high-performance synchronous rectifier which can replace the Schottky diode rectification in the flyback converter to improve efficiency, which supports DCM, CCM and QR operations. A great flexibility for system designing is brought by Self-supply which supports operations with both low-side rectification and high-side rectification without an auxiliary winding.

10.1 Conduction Phase

After SR VG turns on, a minimum blanking time TB_ON is required to prevent the parasitic ringing from falsely turning off SR VG. The minimum turn-on blanking time is around 1.0 μ s for MK1283, during which the turn off threshold is increased to 2V. Right before TB_ON timer expires, MK1283 starts monitoring VDS against a -40mV value to determine if internal VG needs to be slowly discharged. This operation adjusts VDS of SR MOSFET to be around -40mV until the current through SR MOSFET drops to zero.

10.2 Turn Off Phase

MK1283's turn-off threshold is different at different time. Within the minimum turn-on blanking time TB_ON, VDS turn-off threshold is 2V which is the same as VB_OFF. After the minimum turn-on blanking time TB_ON, the turn-off threshold is around 0V, that combines with extremely fast 10ns turn-off propagation delay and 4A VG pull-down (sinking) current, synchronous rectifier is able to be turned off not too early which causes more SR FET body diode conduction time and more negative turn-off ringing, or not too late which creates risk of shoot through between primary side and SR side.

11. Typical Implementations

MK1283 supports both high side rectification and low side rectification to replace Schottky diode without the need of auxiliary winding as shown in Figure 2 and Figure 3. VCC is powered from pin VD and regulated at ~9V even when Vout is much lower than 5V. A 0.1 uF bypass capacitor is suggested to regulate the bias voltage and reduce noise coupling from switching.

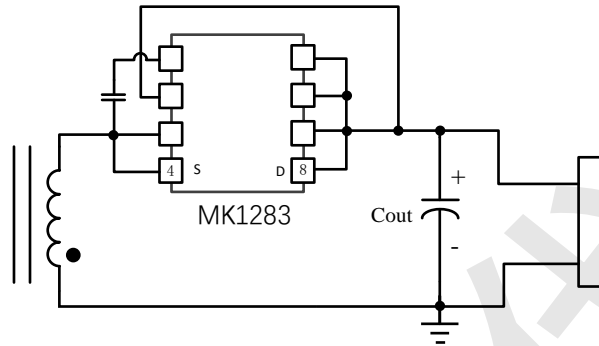

Figure 2. The High side rectification

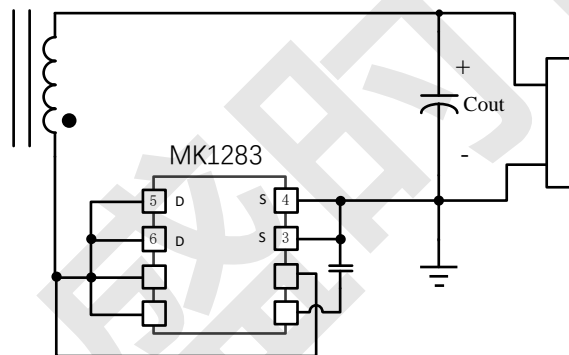
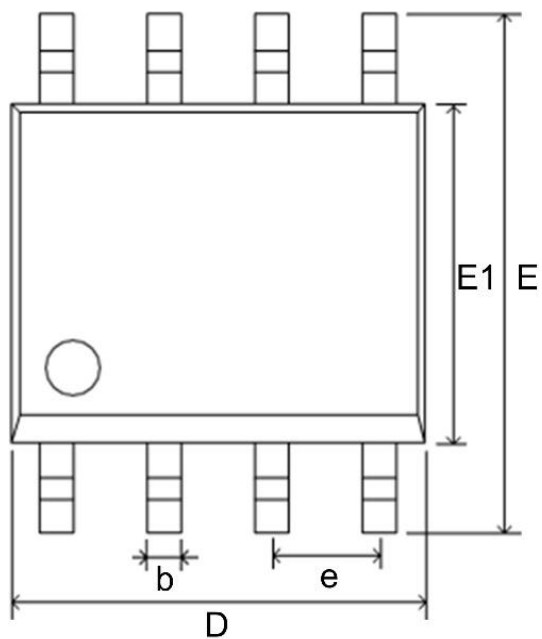
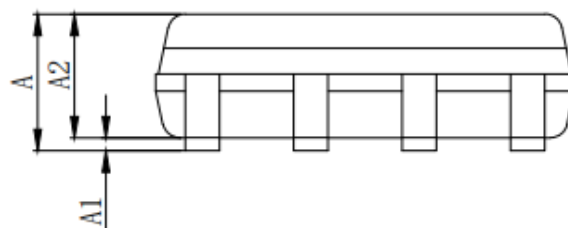

Figure 3. The low side rectification

12. Package Information (SOP-8)

TOP VIEW

FRONT VIEW

SIDE VIEW

Symbol	Dimensions In Millimeters	
	MIN	MAX
A	1.3	1.75
A1	0.05	0.25
A2	1.25	1.65
b	0.33	0.51
c	0.2	0.25
D	4.7	5.1
E	5.8	6.2
E1	3.8	4.0
e	1.270(BSC)	
L	0.4	1.27
θ	0°	8°