

ML0308 Backlight LED Boost Converter

The ML0308 is a step-up DC-DC converter specifically designed to drive up to four white LEDs in series from a single lithium-ion cell. The device provides regulated and inherently matched current to the LEDs with additional functions: automatic soft-start, output overvoltage protection, ON/OFF and dimming control. The ML0308 switches at 1.0 MHz, featuring the use of tiny external components.

PACKAGE INFORMATION

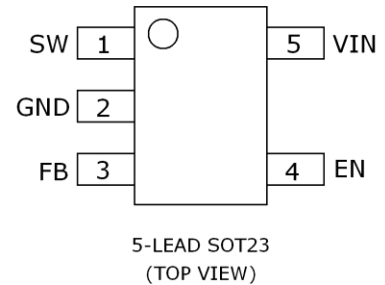

Features

- Inherently-matched LED current
- Drives up to four white LEDs from 3.6V supply
- Automatic soft-start
- Output overvoltage protection
- High efficiency

Applications

- LED backlighting with dimming control
- High efficiency step-up converter

MARKING DIAGRAM

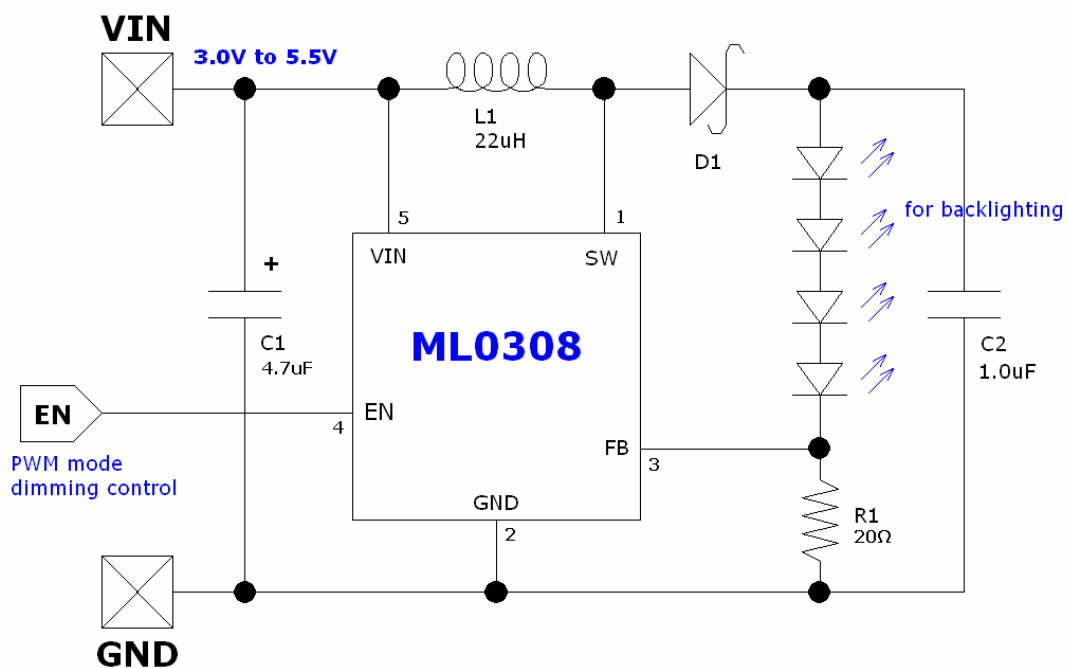

Figure 1: Typical application circuit

ABSOLUTE MAXIMUM RATINGS

Rating	Pin	Value	Unit
Input voltage	VIN	6.0	V
Output voltage	SW	18	V
	EN	10	V
	FB	VIN+0.3	V
Operating temperature		-30 to 80	°C
Storage temperature		-40 to 125	°C

ELECTICAL CHARACTERISTICS All specifications apply under the condition $V_{IN} = 3.0V$ and $T_A = 25^\circ C$ unless specified.
 The • donates the specifications which apply over the full operating temperature range

PARAMETER	CONDITIONS	MIN	TYP	MAX	UNITS
Minimum Operating Voltage		3.0			V
Maximum Operating Voltage				5.5	V
Feedback Voltage	0°C to 85°C	185	200	215	mV
Supply Current Switching EN Pin = 0V			100	150 0.1	uA uA
EN Pin HIGH Threshold				1.2	V
EN Pin LOW Threshold		0.5			V
Switch Frequency		0.7	1.0	1.53	MHz
Duty Ratio		• 73	75	77	%
MOSFET Current Limit		• 180	250		mA
MOSFET ON Resistance	$V_{IN} = 3.0V, I_{DS} = 100mA$				Ω
MOSFET Leakage Current	$V_{IN} = 5.5V$			1.0	uA
Overshoot Limit			16.7	17.5	V
Soft-start Time			200		us

PIN FUNCTION DESCRIPTION

Pin	Description
SW (Pin 1)	This pin is the power side of the external inductor and must be connected to the external Schottky diode. It provides the output current to the load. Since the boost converter operates in a current loop mode, the output voltage can range up to 16V but shall not exceed this limit.
GND (Pin 2)	This pin is the system ground for the ML0308 and carries both the power and the analog signals. High quality ground must be provided to avoid spikes and/or uncontrolled operation. Care must be observed to avoid high-density current flow in a limited PCB copper track so a robust ground plane connection is recommended.
FB (Pin 3)	This pin provides the output current range adjustment by means of a sense resistor connected to the internal analog control circuitry.
EN (Pin 4)	This pin is the chip-enable Pin. Ground this pin to shutdown the chip. Apply a clock with different duty ratio to control brightness of the LEDs.
VIN (Pin 5)	The external voltage supply is connected to this pin. A high quality reservoir capacitor must be connected across pin 5 and Ground to achieve the specified output voltage parameters. A 4.7uF/6.3 V, low ESR capacitor must be connected as close as possible across pin 5 and ground pin 2.

INTERNAL BLOCK DIAGRAM

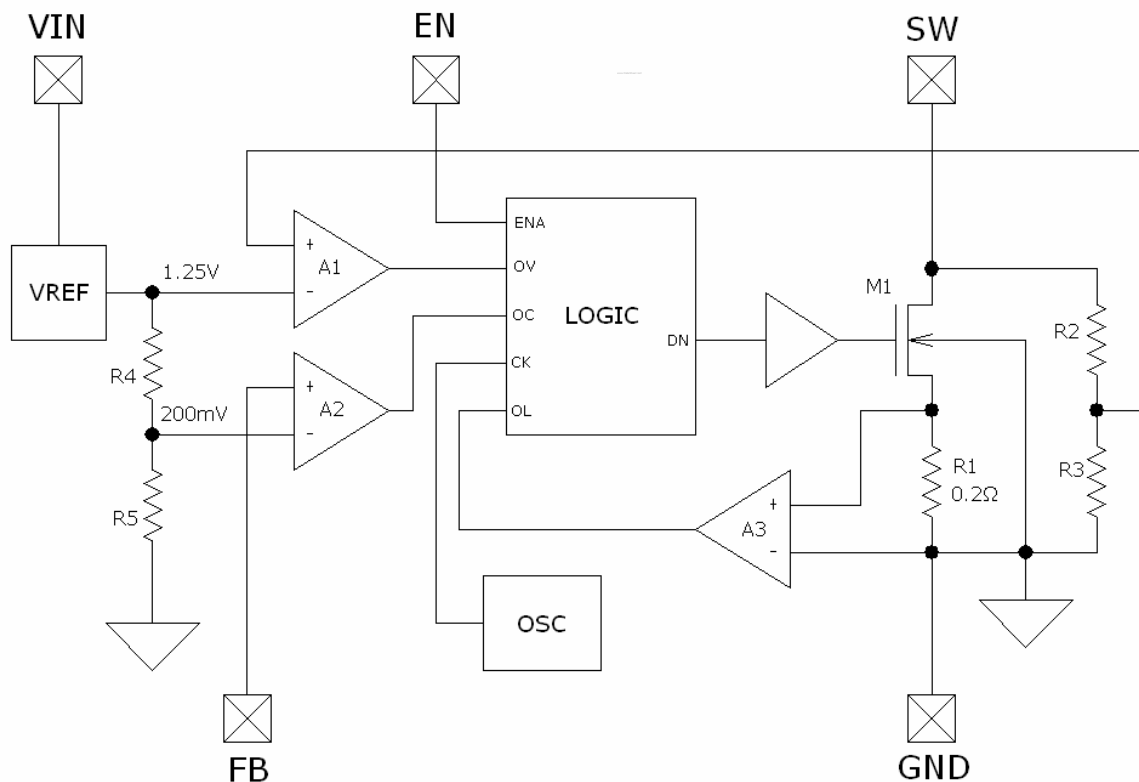

Figure 2: Internal block diagram

THEORY OF OPERATION

The ML0308 uses a PFM, current mode control scheme to provide excellent line and load regulation. Its operation can be best explained with reference to figure 2 and figure 1. The oscillator generates a clock of 1.0MHz with 75% duty ratio for the main control logic. When EN pin goes HIGH, the power MOSFET switches at 1.0 MHz to drive the LED current up to the target level. When the inductor current reaches the limit, comparator A3 will toggle and the MOSFET will stop charging the inductor until the inductor current falls below the limit. Therefore, soft-start is achieved and potential hazards from explosive startup are avoided. When LED current reaches and rises over the regulation point, feedback voltage at FB pin will raise over 200mV and comparator A2 toggles. The chip will then stop switching the MOSFET until LED current falls below the threshold. Therefore, LED current is regulated and the threshold.

HISTORY OF REVISION

REV	DESCRIPTION	DATE
PRE0	Preliminary Release	12/03/2004
PRE1	Preliminary Release1	18/08/2004

DISCLAIMER:

The information presented in this document does not form part of any quotation or contract, is believed to be accurate and reliable and may be changed without notice. No liability will be accepted by the publisher for any consequence of its use.