

**Legacy Device:** Motorola MC145403, MC145404, MC145405, MC145408

These devices are silicon gate CMOS ICs that combine both the transmitter and receiver to fulfill the electrical specifications of EIA Standard 232-E and CCITT V.28. The drivers feature true TTL input compatibility, slew rate limiting outputs, 300  $\Omega$  power-off source impedance, and output typically switching to within 25% of the supply rails. The receivers can handle up to  $\pm 25$  V while presenting 3 to 7 k $\Omega$  impedance. Hysteresis in the receivers aid in the reception of noisy signals. By combining both drivers and receivers in a single CMOS chip, these devices provide efficient, low-power solutions for both EIA-232-E and V.28 applications.

These devices offer the following performance features:

- Operating Temperature Range  $T_A = -40^\circ$  to  $+85^\circ\text{C}$

#### Drivers

- $\pm 5$  to  $\pm 12$  V Supply Range
- 300  $\Omega$  Power-Off Source Impedance
- Output Current Limiting
- TTL and CMOS Compatible Inputs
- Driver Slew Rate Range Limited to 30 V/ $\mu\text{s}$  Maximum

#### Receivers

- $\pm 25$  V Input Range
- 3 to 7 k $\Omega$  Input Impedance
- 0.8 V of Hysteresis for Enhanced Noise Immunity
- TTL and CMOS Compatible Outputs

#### Available Driver/Receiver Combinations

Device	Drivers	Receivers	Figure	No. of Pins
ML145403	3	5	1	20
ML145404	4	4	2	20
ML145405	5	3	3	20
ML145408	5	5	4	24

Alternative EIA-232 devices to consider are:

#### Three Supply

ML145406 (3 x 3)

#### Single Supply

ML145407 (3 x 3)

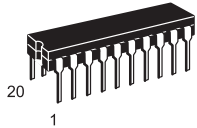

**P DIP 20 = RP**  
PLASTIC DIP  
CASE 738

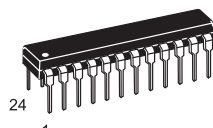

**P DIP 24 = LP**  
PLASTIC DIP  
CASE 724

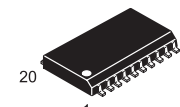

**SO 20W = -6P**  
SOG PACKAGE  
CASE 751D

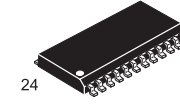

**SO 24W = -6P**  
SOG PACKAGE  
CASE 751E

**CROSS REFERENCE/ORDERING INFORMATION**

<u>PACKAGE</u>	<u>MOTOROLA</u>	<u>LANSDALE</u>
P DIP 20	MC145403P	ML145403RP
SO 20W	MC145403DW	ML145403-6P
P DIP 20	MC145404P	ML145404RP
SO 20W	MC145404DW	ML145404-6P
P DIP 20	MC145405P	ML145405RP
SO 20W	MC145405DW	ML145405-6P
P DIP 24N	MC145408P	ML145408LP
SO 24W	MC145408DW	ML145408-6P

**Note:** Lansdale lead free (**Pb**) product, as it becomes available, will be identified by a part number prefix change from **ML** to **MLE**.

**PIN ASSIGNMENTS  
(DIP AND SOG)**

**ML145403  
3 DRIVERS/5 RECEIVERS**

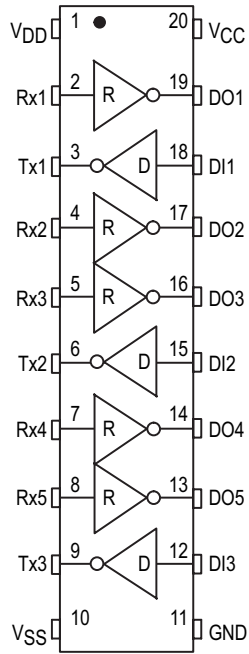

**ML145404  
4 DRIVERS/4 RECEIVERS**

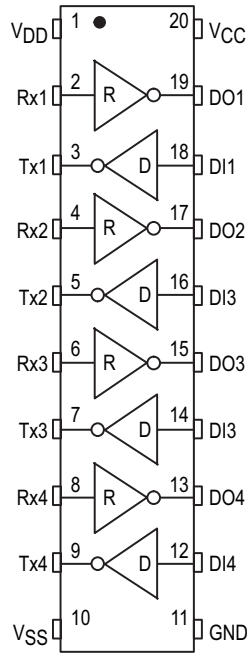

**ML145405  
5 DRIVERS/3 RECEIVERS**

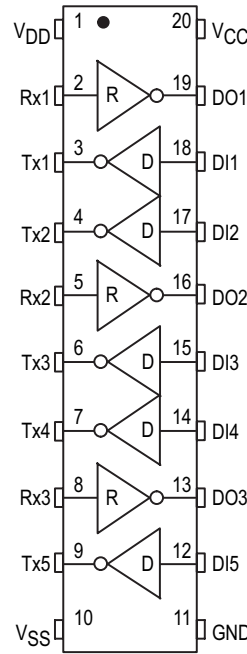

**ML145408  
5 DRIVERS/5 RECEIVERS**

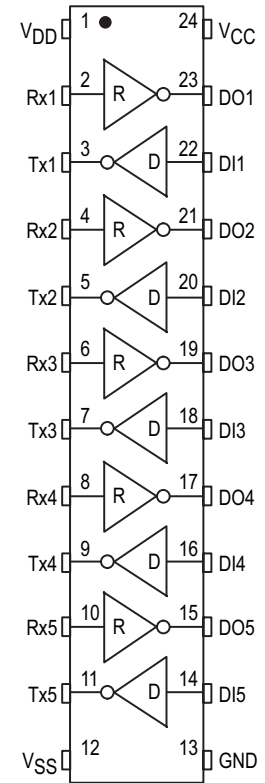

**FUNCTIONAL DIAGRAM**

**RECEIVER**

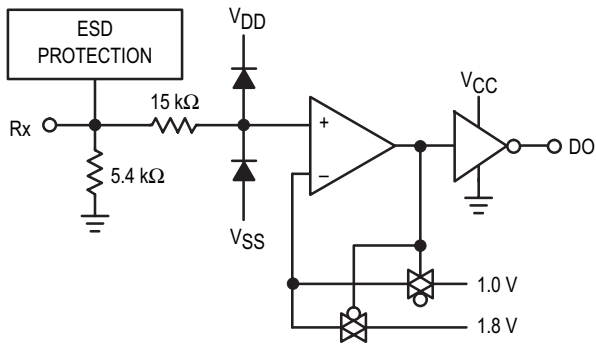

**DRIVER**

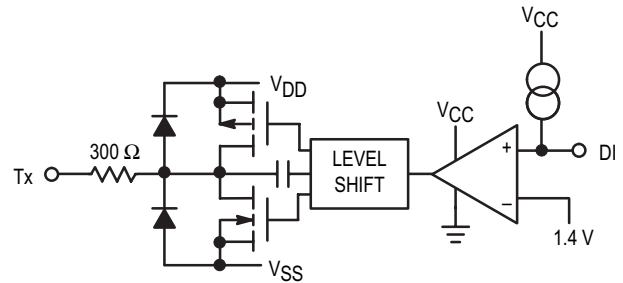

### ABSOLUTE MAXIMUM RATINGS

(Voltages referenced to GND, except where noted)

Rating	Symbol	Value	Unit
DC Supply Voltage ( $V_{DD} \geq V_{CC}$ )	$V_{DD}$ $V_{SS}$ $V_{CC}$	- 0.5 to + 13.5 + 0.5 to - 13.5 - 0.5 to + 6.0	V
Input Voltage Range Rx1 – Rxn DI1 – DIN	$V_{IR}$	$V_{SS} - 15$ to $V_{DD} + 15$ 0.5 to $V_{CC} + 15$	V
DC Current Drain per Pin	I	± 00	mA
Power Dissipation	$P_D$	1	W
Operating Temperature Range	$T_A$	- 40 to + 85	°C
Storage Temperature Range	$T_{stg}$	- 85 to + 150	°C

This device contains circuitry to protect the inputs and outputs against damage due to high static voltages or electric fields; however, it is advised that normal precautions be taken to avoid applications of any voltage higher than maximum rated voltages to this high impedance circuit.

For proper operation it is recommended that  $V_{out}$  and  $V_{in}$  be constrained to the ranges described as follows:

Digital I/O: Driver Inputs (DI):

( $GND \leq V_{DI} \leq V_{CC}$ ).

Receiver Outputs (DO):

( $GND \leq V_{DO} \leq V_{CC}$ ).

EIA-232 I/O: Driver Outputs (Tx):

( $V_{SS} \leq V_{Tx1} - Txn \leq V_{DD}$ ).

Receiver Inputs (Rx):

$V_{SS} - 15 V \leq V_{Rx1} - Rxn \leq V_{DD} + 15 V$ .

Reliability of operation is enhanced if unused outputs are tied off to an appropriate logic voltage level (e.g., either GND or  $V_{CC}$  for DI, and GND for Rx).

### DC ELECTRICAL CHARACTERISTICS (All polarities referenced to GND = 0 V, $T_A = -40$ to + 85°C)

Parameter	Symbol	Min	Typ	Max	Unit	
DC Supply Voltage	$V_{DD}$ $V_{SS}$ $V_{CC}$	4.5 - 4.5 4.5	5 to 12 - 5 to - 12 5	13.2 - 13.2 5.5	V	
Quiescent Supply Current (Outputs Unloaded, Inputs Low)	$V_{DD} = + 12 V$ $V_{SS} = - 12 V$ $V_{CC} = + 5 V$	$I_{DD}$ $I_{SS}$ $I_{CC}$	— — —	425 - 400 110	635 - 600 200	μA

### RECEIVER ELECTRICAL SPECIFICATIONS

(Voltage polarities referenced to GND = 0 V,  $V_{DD} = + 12 V$ ,  $V_{SS} = - 12 V$ ,  $T_A = - 40$  to + 85°C,  $V_{CC} = + 5 V$ , ± 10%)

Characteristic	Symbol	Min	Typ	Max	Unit
Input Turn-On Threshold $V_{DO} = V_{OL}$	Rx1 – Rxn $V_{on}$	1.35	1.8	2.35	V
Input Turn-Off Threshold $V_{DO} = V_{OH}$	Rx1 – Rxn $V_{off}$	0.75	1	1.25	V
Input Threshold Hysteresis $\Delta = V_{on} - V_{off}$	$V_{hys}$	0.6	0.8	—	V
Input Resistance ( $V_{SS} - 15 V \leq V_{Rx1} - Rxn \leq (V_{DD} + 15 V)$ )	$R_{in}$	3	5.4	7	kΩ
High Level Output Voltage $V_{Rx} = - 3$ to $- 25 V^*$ (DO1 – DON)	$I_{out} = - 20 \mu A$ $I_{out} = - 1.0 mA$ $V_{OH}$	4.9 3.8	4.9 4.3	— —	V
Low Level Output Voltage $V_{Rx} = + 3$ to + 25 V* (DO1 – DON)	$I_{out} = + 2 mA$ $I_{out} = + 4 mA$ $V_{OL}$	— —	0.02 0.5	0.5 0.7	V

\* This is the range of input voltages as specified by EIA-232-E to cause a receiver to be in the high or low.

**DRIVER ELECTRICAL SPECIFICATIONS**

(Voltage Polarities Referenced to GND = 0 V, V<sub>DD</sub> = + 12 V, V<sub>SS</sub> = - 12 V, T<sub>A</sub> = - 40 to + 85°C, V<sub>CC</sub> = + 5 V, ± 10%)

Characteristic	Symbol	Min	Typ	Max	Unit
Digital Input Voltage Logic 0 Logic 1	DI1 – DI <i>n</i>  V <sub>IL</sub> V <sub>IH</sub>	— 2	— —	0.8 —	V
Input Current V <sub>DI</sub> = GND V <sub>DI</sub> = V <sub>CC</sub>	DI1 – DI <i>n</i>  I <sub>IL</sub> I <sub>IH</sub>	— —	7 —	— ± 1.0	μA
Output High Voltage V <sub>DI</sub> = Logic 0, R <sub>L</sub> = 3 kΩ V <sub>DD</sub> = + 5.0 V, V <sub>SS</sub> = - 5.0 V V <sub>DD</sub> = + 6.0 V, V <sub>SS</sub> = - 6.0 V V <sub>DD</sub> = + 12.0 V, V <sub>SS</sub> = - 12.0 V	Tx1 – Tx <i>n</i>  V <sub>OH</sub>	3.5 4.3 9.2	3.9 4.7 9.5	— — —	V
Output Low Voltage* V <sub>DI</sub> = Logic 1, R <sub>L</sub> = 3 kΩ V <sub>DD</sub> = + 5.0 V, V <sub>SS</sub> = - 5.0 V V <sub>DD</sub> = + 6.0 V, V <sub>SS</sub> = - 6.0 V V <sub>DD</sub> = + 12.0 V, V <sub>SS</sub> = - 12.0 V	Tx1 – Tx <i>n</i>  V <sub>OL</sub>	- 4 - 4.5 - 10	- 4.3 - 5.2 - 10.3	— — —	V
Input Current (Figure 5)	Tx1 – Tx <i>n</i>  Z <sub>off</sub>	300	—	—	Ω
Output Short Circuit Current V <sub>DD</sub> = + 12 V, V <sub>SS</sub> = - 12 V Tx Shorted to GND** Tx Shorted to ± 15 V***	Tx1 – Tx <i>n</i>  I <sub>SC</sub>	— —	± 22 ± 60	± 60 ± 100	mA

\* Voltage specifications are in terms of absolute values.

\*\* Specification is for one Tx output pin to be shorted at a time. Should all three driver outputs be shorted simultaneously, device power dissipation limits will be exceeded.

\*\*\* This condition could exceed package limitations.

**SWITCHING CHARACTERISTICS** (V<sub>CC</sub> = + 5 V, ± 10%, V<sub>DD</sub> = + 12 V, V<sub>SS</sub> = - 12 V, T<sub>A</sub> = - 40 to + 85°C; See Figures 2 and 3)

Characteristic	Symbol	Min	Typ	Max	Unit
<b>Drivers</b>					
Propagation Delay Time Tx Low-to-High R <sub>L</sub> = 3 kΩ, C <sub>L</sub> = 50 pF  High-to-Low R <sub>L</sub> = 3 kΩ, C <sub>L</sub> = 50 pF	t <sub>PLH</sub>	—	500	1000	ns
	t <sub>PHL</sub>	—	700	1000	
Output Slew Rate Minimum Load R <sub>L</sub> = 7 kΩ, C <sub>L</sub> = 0 pF (V <sub>DD</sub> = 6 to 12 V, V <sub>SS</sub> = - 6 to - 12 V)  Maximum Load R <sub>L</sub> = 3 kΩ, C <sub>L</sub> = 2500 pF (V <sub>DD</sub> = 12 V, V <sub>SS</sub> = - 12 V, V <sub>CC</sub> = 5 V)	SR	—	± 6	± 30	V/μs
		4	—	—	
<b>Receivers</b> (C <sub>L</sub> = 50 pF)					
Propagation Delay Time Low-to-High  High-to-Low	t <sub>PLH</sub>	—	360	610	ns
	t <sub>PHL</sub>	—	130	610	
Output Rise Time	t <sub>r</sub>	—	250	400	ns
Output Fall Time	t <sub>f</sub>	—	40	100	ns

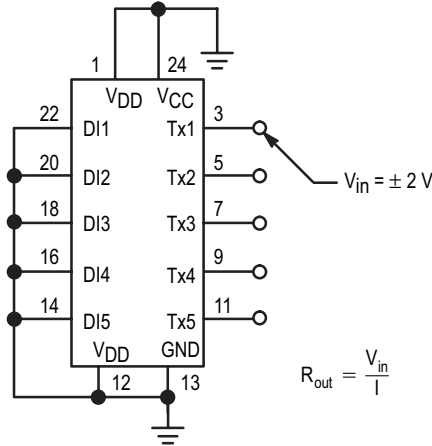

Figure 1. Power-Off Source Resistance Illustrated for ML145408

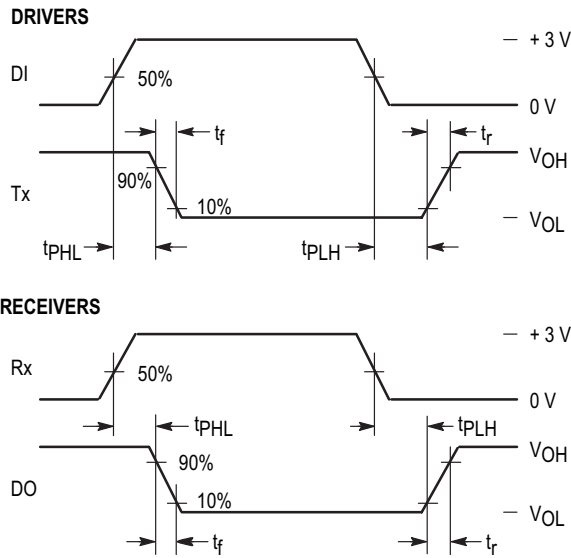

Figure 2. Switching Characteristics

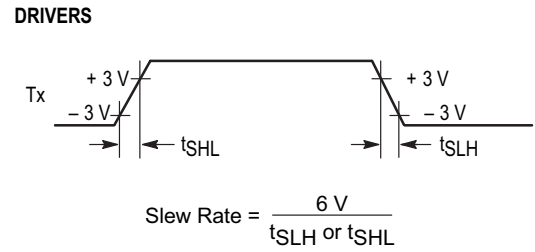

Figure 3. Slew Rate Characteristics

**PIN DESCRIPTIONS**

**VCC**  
**Digital Power Supply**

The digital supply pin, which is connected to the logic power supply (+ 5.5 V maximum).

**GND**  
**Ground**

Ground return pin is typically connected to the signal ground pin of the EIA-232-E connector (Pin 7) as well as to the logic power supply ground.

**VDD**  
**Most Positive Device Pin**

The most positive power supply pin, which is typically + 5 to + 12 V.

**VSS**  
**Most Negative Device Pin**

The most negative power supply pin, which is typically - 5 to - 12 V.

**Rx1 – Rxn**  
**Receive Data Input Pins**

These are the EIA-232-E receive signal inputs. A voltage between + 3 and + 25 V is decoded as a space, and causes the corresponding DO pin to swing to ground (0 V). A voltage between - 3 and - 25 V is decoded as a mark, and causes the corresponding DO pin to swing to VCC.

**DO1 – DOn**  
**Data Output Pins**

These are the receiver digital output pins which swing from VCC to GND. Each output pin is capable of driving one LSTTL input load.

**DI1 – DI<sub>n</sub>**  
**Data Input Pins**

These are the high impedance digital input pins to the drivers. Input voltage levels on these pins are LSTTL compatible and must be between V<sub>CC</sub> and GND. A weak pull-up on each input sets all unused DI pins to V<sub>CC</sub>, causing the corresponding unused driver outputs to be at V<sub>SS</sub>.

**Tx1 – Tx<sub>n</sub>**  
**Transmit Data Output Pins**

These are the EIA-232-E transmit signal output pins, which swing from V<sub>DD</sub> to V<sub>SS</sub>. A logic 1 at the DI input causes the corresponding Tx output to swing to V<sub>SS</sub>. A logic 0 at the DI input causes the corresponding Tx out to swing to V<sub>DD</sub>. The actual levels and slew rate achieved will depend on the output loading (R<sub>L</sub>//C<sub>L</sub>).

**LEGACY APPLICATION INFORMATION**

**POWER SUPPLY CONSIDERATIONS**

Figure 4 shows a technique to guard against excessive device current.

The diode D1 prevents excessive current from flowing through an internal diode from the V<sub>CC</sub> pin to the V<sub>DD</sub> pin when V<sub>DD</sub> < V<sub>CC</sub> by approximately 0.6 V or greater. This high current condition can exist for a short period of time during power up/down. Additionally, if the + 12 V supply is

switched off while the + 5 V is on and the off supply is a low impedance to ground, the diode D1 will prevent current flow through the internal diode.

The diode D2 is used as a voltage clamp, to prevent V<sub>SS</sub> from drifting positive to V<sub>CC</sub>, in the event that power is removed from V<sub>SS</sub> (Pin 12). If V<sub>SS</sub> power is removed, and the impedance from the V<sub>SS</sub> pin to ground is greater than approximately 3 kΩ, this pin will be pulled to V<sub>CC</sub> by internal circuitry causing excessive current in the V<sub>CC</sub> pin.

If by design, neither of the above conditions are allowed to exist, then the diodes D1 and D2 are not required.

**ESD PROTECTION – CAUTION**

ESD protection on IC devices that have their pins accessible to the outside world is essential. High static voltages applied to the pins when someone touches them either directly or indirectly can cause damage to gate oxides and transistor junctions by coupling a portion of the energy from the I/O pin to the power supply buses of the IC. This coupling will usually occur through the internal ESD protection diodes. The key to protecting the IC is to shunt as much of the energy to ground as possible before it enters the IC. Figure 4 shows a technique which will clamp the ESD voltage at approximately ± 15 V using the MMBZ15VDLT1. Any residual voltage which appears on the supply pins is shunted to ground through the capacitors C1 – C3. This scheme has provided protection to the interface part up to ± 10kV, using the human body model test.

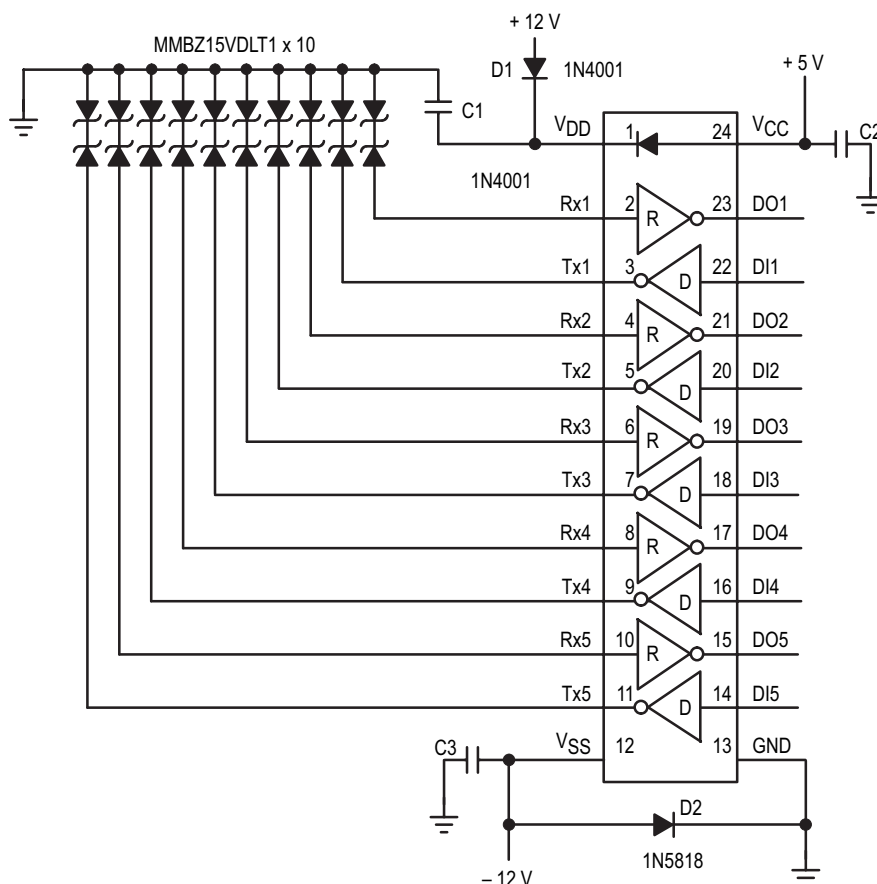
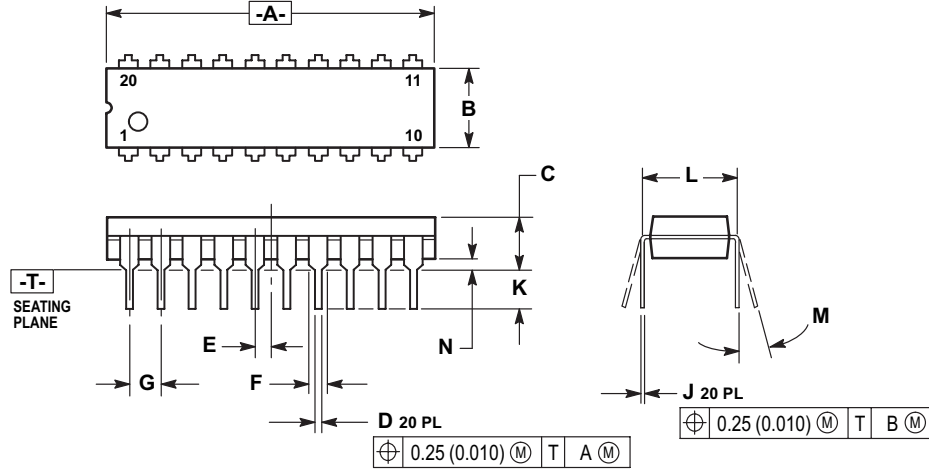

Figure 4.

OUTLINE DIMENSIONS

P DIP 20 = RP  
(ML145403RP, ML145404RP, ML145405RP)  
PLASTIC DIP  
CASE 738-03



- NOTES:
1. DIMENSIONING AND TOLERANCING PER ANSI Y14.5M, 1982.
  2. CONTROLLING DIMENSION: INCH.
  3. DIMENSION L TO CENTER OF LEAD WHEN FORMED PARALLEL.
  4. DIMENSION B DOES NOT INCLUDE MOLD FLASH.

DIM	INCHES		MILLIMETERS	
	MIN	MAX	MIN	MAX
A	1.010	1.070	25.66	27.17
B	0.240	0.260	6.10	6.60
C	0.150	0.180	3.81	4.57
D	0.015	0.022	0.39	0.55
E	0.050 BSC		1.27 BSC	
F	0.050	0.070	1.27	1.77
G	0.100 BSC		2.54 BSC	
J	0.008	0.015	0.21	0.38
K	0.110	0.140	2.80	3.55
L	0.300 BSC		7.62 BSC	
M	0°	15°	0°	15°
N	0.020	0.040	0.51	1.01

P DIP 24 = LP  
(ML145408LP)  
PLASTIC DIP  
CASE 724-03

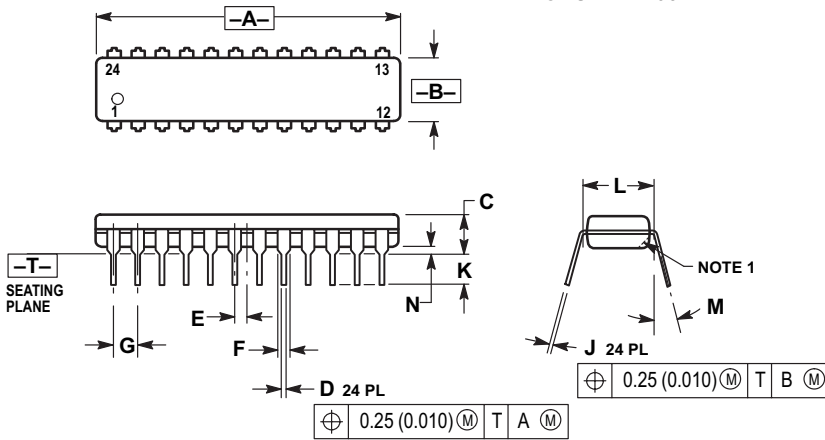

- NOTES:
1. CHAMFERED CONTOUR OPTIONAL.
  2. DIMENSION L TO CENTER OF LEADS WHEN FORMED PARALLEL.
  3. DIMENSIONING AND TOLERANCING PER ANSI Y14.5M, 1982.
  4. CONTROLLING DIMENSION: INCH.

DIM	INCHES		MILLIMETERS	
	MIN	MAX	MIN	MAX
A	1.230	1.265	31.25	32.13
B	0.250	0.270	6.35	6.85
C	0.145	0.175	3.69	4.44
D	0.015	0.020	0.38	0.51
E	0.050 BSC		1.27 BSC	
F	0.040	0.060	1.02	1.52
G	0.100 BSC		2.54 BSC	
J	0.007	0.012	0.18	0.30
K	0.110	0.140	2.80	3.55
L	0.300 BSC		7.62 BSC	
M	0°	15°	0°	15°
N	0.020	0.040	0.51	1.01

### OUTLINE DIMENSIONS

**SO 20W = -6P**  
**(ML145403-6P, ML145404-6P, ML145405-6P)**  
**SOG PACKAGE**  
**CASE 751D-04**

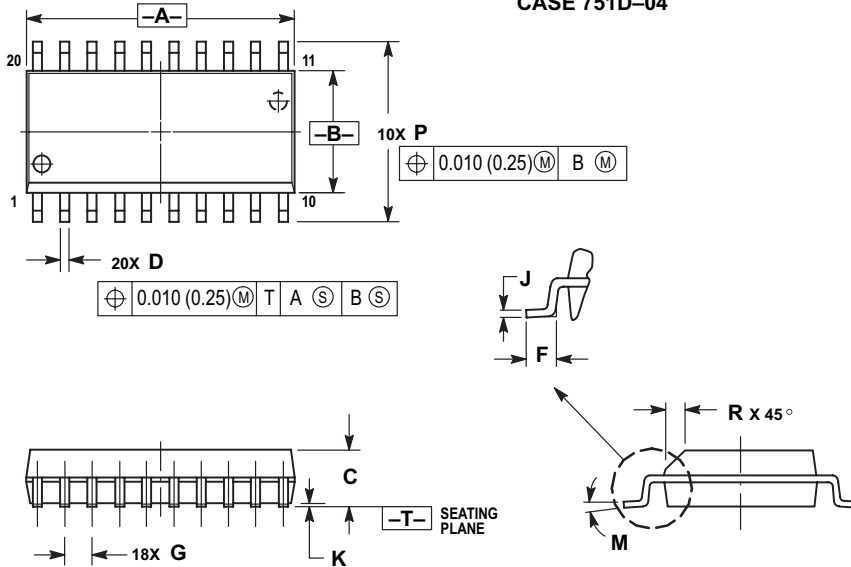

- NOTES:
1. DIMENSIONING AND TOLERANCING PER ANSI Y14.5M, 1982.
  2. CONTROLLING DIMENSION: MILLIMETER.
  3. DIMENSIONS A AND B DO NOT INCLUDE MOLD PROTRUSION.
  4. MAXIMUM MOLD PROTRUSION 0.150 (0.006) PER SIDE.
  5. DIMENSION D DOES NOT INCLUDE DAMBAR PROTRUSION. ALLOWABLE DAMBAR PROTRUSION SHALL BE 0.13 (0.005) TOTAL IN EXCESS OF D DIMENSION AT MAXIMUM MATERIAL CONDITION.

DIM	MILLIMETERS		INCHES	
	MIN	MAX	MIN	MAX
A	12.65	12.95	0.499	0.510
B	7.40	7.60	0.292	0.299
C	2.35	2.65	0.093	0.104
D	0.35	0.49	0.014	0.019
F	0.50	0.90	0.020	0.035
G	1.27 BSC		0.050 BSC	
J	0.25	0.32	0.010	0.012
K	0.10	0.25	0.004	0.009
M	0°	7°	0°	7°
P	10.05	10.55	0.395	0.415
R	0.25	0.75	0.010	0.029

**SO 24W = -6P**  
**(ML145408-6P)**  
**SOG PACKAGE**  
**CASE 751E-04**

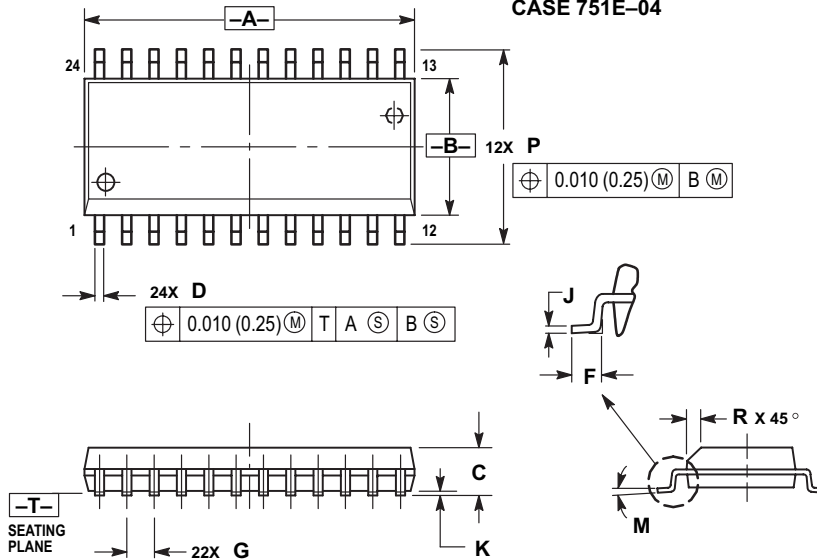

- NOTES:
1. DIMENSIONING AND TOLERANCING PER ANSI Y14.5M, 1982.
  2. CONTROLLING DIMENSION: MILLIMETER.
  3. DIMENSIONS A AND B DO NOT INCLUDE MOLD PROTRUSION.
  4. MAXIMUM MOLD PROTRUSION 0.15 (0.006) PER SIDE.
  5. DIMENSION D DOES NOT INCLUDE DAMBAR PROTRUSION. ALLOWABLE DAMBAR PROTRUSION SHALL BE 0.13 (0.005) TOTAL IN EXCESS OF D DIMENSION AT MAXIMUM MATERIAL CONDITION.

DIM	MILLIMETERS		INCHES	
	MIN	MAX	MIN	MAX
A	15.25	15.54	0.601	0.612
B	7.40	7.60	0.292	0.299
C	2.35	2.65	0.093	0.104
D	0.35	0.49	0.014	0.019
F	0.41	0.90	0.016	0.035
G	1.27 BSC		0.050 BSC	
J	0.23	0.32	0.009	0.013
K	0.13	0.29	0.005	0.011
M	0°	8°	0°	8°
P	10.05	10.55	0.395	0.415
R	0.25	0.75	0.010	0.029

Lansdale Semiconductor reserves the right to make changes without further notice to any products herein to improve reliability, function or design. Lansdale does not assume any liability arising out of the application or use of any product or circuit described herein; neither does it convey any license under its patent rights nor the rights of others. "Typical" parameters which may be provided in Lansdale data sheets and/or specifications can vary in different applications, and actual performance may vary over time. All operating parameters, including "Typicals" must be validated for each customer application by the customer's technical experts. Lansdale Semiconductor is a registered trademark of Lansdale Semiconductor, Inc.