

PFC and Dual Output PWM Controller Combo

GENERAL DESCRIPTION

The ML4826 is a high power controller for power factor corrected, switched mode power supplies. PFC allows the use of smaller, lower cost bulk capacitors, reduces power line loading and stress on the switching FETs, and results in a power supply that fully complies with IEC1000-3-2 specifications. The ML4826 includes circuits for the implementation of a leading edge, average current "boost" type power factor correction and a trailing edge, pulse width modulator (PWM) with dual totem-pole outputs.

The device is available in two versions; the ML4826-1 ($f_{PWM} = f_{PFC}$) and the ML4826-2 ($f_{PWM} = 2 \times f_{PFC}$). Doubling the switching frequency of the PWM allows the user to design with smaller output components while maintaining the optimum operating frequency for the PFC. An over-voltage comparator shuts down the PFC section in the event of a sudden decrease in load. The PFC section also includes peak current limiting and input voltage brown-out protection. The PWM section can be operated in current or voltage mode at up to 250kHz and includes a duty cycle limit to prevent transformer saturation.

FEATURES

- Internally synchronized PFC and PWM in one IC
- Low total harmonic distortion
- Reduced ripple current in the storage capacitor between the PFC and PWM sections
- Average current, continuous boost, leading edge PFC
- High efficiency trailing edge PWM with dual totem-pole outputs
- Average line voltage compensation with brown-out control
- PFC overvoltage comparator eliminates output "runaway" due to load removal
- Current-fed multiplier for improved noise immunity
- Overvoltage protection, UVLO, and soft start

BLOCK DIAGRAM

*** This Part Is End Of Life As Of August 1, 2000**

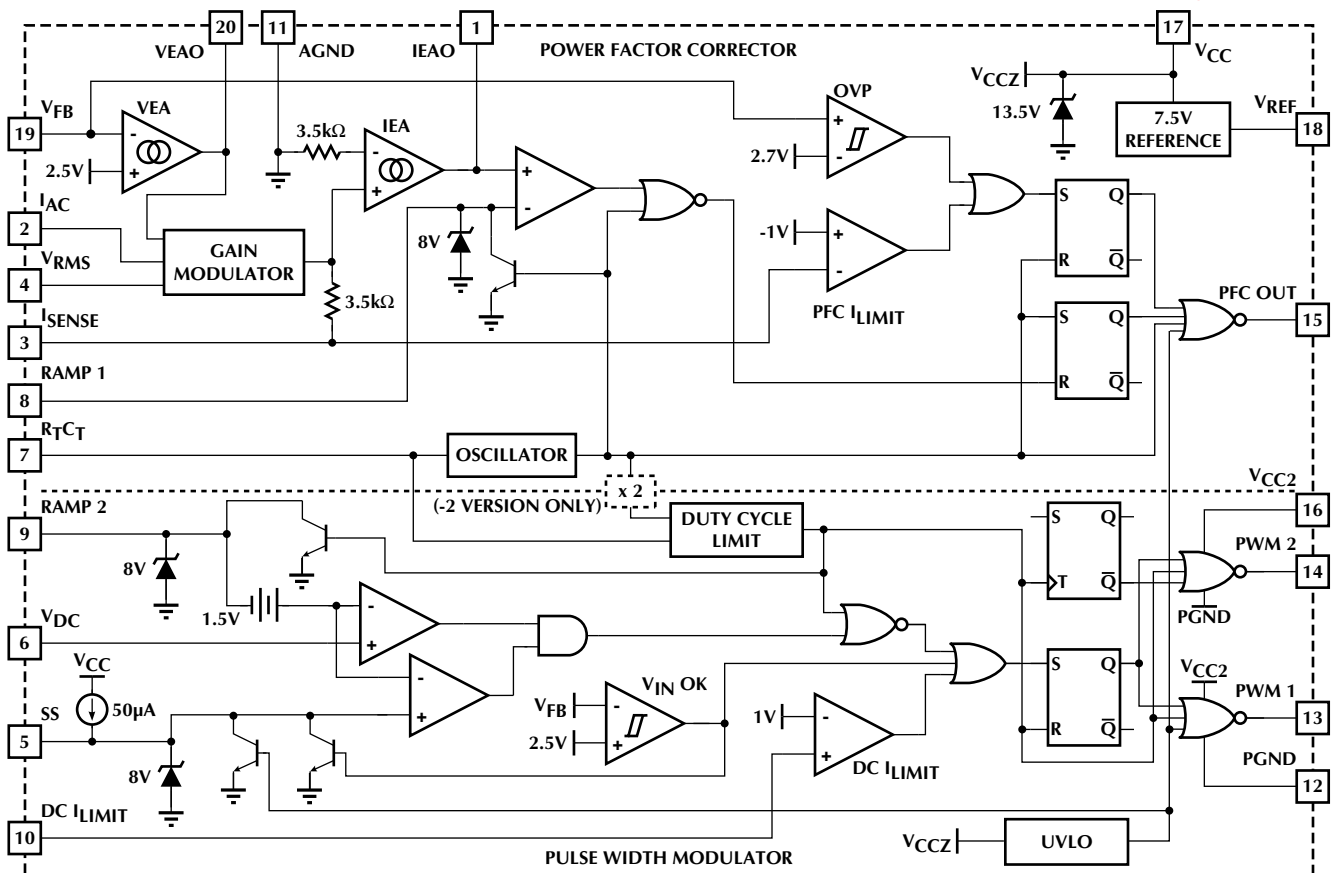

PIN CONFIGURATION

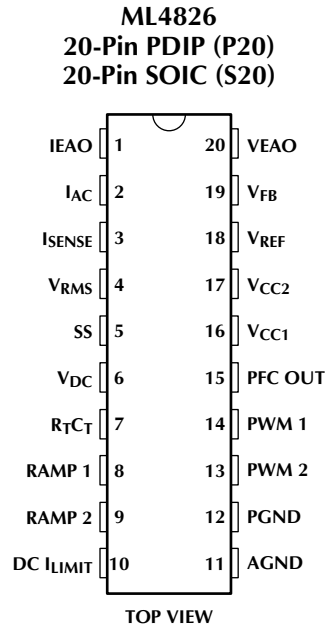

PIN DESCRIPTION

PIN	NAME	FUNCTION	PIN	NAME	FUNCTION
1	IEAO	PFC transconductance current error amplifier output	11	AGND	Analog signal ground
2	I _{AC}	PFC gain control reference input	12	PGND	Return for the PWM totem-pole outputs
3	I _{SENSE}	Current sense input to the PFC current limit comparator	13	PWM 2	PWM driver 2 output
4	V _{RMS}	Input for PFC RMS line voltage compensation	14	PWM 1	PWM drive 1 output
5	SS	Connection point for the PWM soft start capacitor	15	PFC OUT	PFC driver output
6	V _{DC}	PWM voltage feedback input	16	V _{CC2}	Positive supply for the PWM drive outputs
7	R _{TCT}	Connection for oscillator frequency setting components	17	V _{CC1}	Positive supply (connected to an internal shunt regulator).
8	RAMP 1	PFC ramp input	18	V _{REF}	Buffered output for the internal 7.5V reference
9	RAMP 2	When in current mode, this pin functions as the current sense input; when in voltage mode, it is the PWM input from the PFC output (feedforward ramp)	19	V _{FB}	PFC transconductance voltage error amplifier input
10	DC I _{LIMIT}	PWM current limit comparator input	20	VEAO	PFC transconductance voltage error amplifier output

ABSOLUTE MAXIMUM RATINGS

Absolute maximum ratings are those values beyond which the device could be permanently damaged. Absolute maximum ratings are stress ratings only and functional device operation is not implied.

V _{CC} Shunt Regulator Current	55mA
I _{SENSE} Voltage	-3V to 5V
Voltage on Any Other Pin GND - 0.3V to V _{CCZ} + 0.3V	
I _{REF}	20mA
I _{AC} Input Current	10mA
Peak PFC OUT Current, Source or Sink	500mA
Peak PWM OUT Current, Source or Sink	500mA
PFC OUT, PWM 1, PWM 2 Energy Per Cycle	1.5mJ

Junction Temperature	150°C
Storage Temperature Range	-65°C to 150°C
Lead Temperature (Soldering, 10 sec)	260°C
Thermal Resistance (θ_{JA})	
Plastic DIP	67°C/W
Plastic SOIC	95°C/W

OPERATING CONDITIONS

Temperature Range	
ML4826CX	0°C to 70°C
ML4826IX	-40°C to 85°C

ELECTRICAL CHARACTERISTICS

Unless otherwise specified, I_{CC} = 25mA, R_{RAMP1} = R_T = 52.3k Ω , C_{RAMP1} = C_T = 180pF, T_A = Operating Temperature Range (Note 1)

SYMBOL	PARAMETER	CONDITIONS	MIN	TYP	MAX	UNITS
VOLTAGE ERROR AMPLIFIER						
	Input Voltage Range		0		7	V
	Transconductance	V _{NON INV} = V _{INV} , V _{EAO} = 3.75V	50	85	120	μS
	Feedback Reference Voltage		2.4	2.5	2.6	V
	Input Bias Current	Note 2		-0.3	-1.0	μA
	Output High Voltage		6.0	6.7		V
	Output Low Voltage			0.6	1.0	V
	Source Current	$\Delta V_{IN} = \pm 0.5V$, V _{OUT} = 6V	-40	-80		μA
	Sink Current	$\Delta V_{IN} = \pm 0.5V$, V _{OUT} = 1.5V	40	80		μA
	Open Loop Gain		60	75		dB
	Power Supply Rejection Ratio	V _{CCZ} - 3V < V _{CC} < V _{CCZ} - 0.5V	60	75		dB
CURRENT ERROR AMPLIFIER						
	Input Voltage Range		-1.5		2	V
	Transconductance	V _{NON INV} = V _{INV} , V _{EAO} = 3.75V	130	195	310	μS
	Input Offset Voltage			± 3	± 15	mV
	Input Bias Current			-0.5	-1.0	μA
	Output High Voltage		6.0	6.7		V
	Output Low Voltage			0.6	1.0	V
	Source Current	$\Delta V_{IN} = \pm 0.5V$, V _{OUT} = 6V	-40	-90		μA
	Sink Current	$\Delta V_{IN} = \pm 0.5V$, V _{OUT} = 1.5V	40	90		μA
	Open Loop Gain		60	75		dB
	Power Supply Rejection Ratio	V _{CCZ} - 3V < V _{CC} < V _{CCZ} - 0.5V	60	75		dB

ML4826

ELECTRICAL CHARACTERISTICS (Continued)

SYMBOL	PARAMETER	CONDITIONS	MIN	TYP	MAX	UNITS
OVP COMPARATOR						
	Threshold Voltage		2.6	2.7	2.8	V
	Hysteresis		80	115	150	mV
PFC I_{LIMIT} COMPARATOR						
	Threshold Voltage		-0.8	-1.0	-1.15	V
	Δ (PFC I _{LIMIT} - Gain Modulator Output)		100	190		mV
	Delay to Output			150	300	ns
DC I_{LIMIT} COMPARATOR						
	Threshold Voltage		0.9	1.0	1.1	V
	Input Bias Current			± 0.3	± 1	μ A
	Delay to Output			150	300	ns
V_{IN} OK COMPARATOR						
	Threshold Voltage		2.4	2.5	2.6	V
	Hysteresis		0.8	1.0	1.2	V
GAIN MODULATOR						
	Gain (Note 3)	I _{AC} = 100 μ A, V _{RMS} = V _{FB} = 0V	0.36	0.55	0.66	
		I _{AC} = 50 μ A, V _{RMS} = 1.2V, V _{FB} = 0V	1.20	1.80	2.24	
		I _{AC} = 50 μ A, V _{RMS} = 1.8V, V _{FB} = 0V	0.55	0.80	1.01	
		I _{AC} = 100 μ A, V _{RMS} = 3.3V, V _{FB} = 0V	0.14	0.20	0.26	
	Bandwidth	I _{AC} = 100 μ A		10		MHz
	Output Voltage	I _{AC} = 250 μ A, V _{RMS} = 1.15V, V _{FB} = 0V	0.72	0.82	0.95	V
OSCILLATOR						
	Initial Accuracy	T _A = 25°C	180	190	200	kHz
	Voltage Stability	V _{CCZ} - 3V < V _{CC} < V _{CCZ} - 0.5V		1		%
	Temperature Stability			2		%
	Total Variation	Line, Temp	170		210	kHz
	Ramp Valley to Peak Voltage			2.5		V
	Dead Time	PFC Only	-1 Suffix	125	310	ns
			-2 Suffix	250	500	ns
	C _T Discharge Current	V _{RAMP 1} = 0V, V(R _T C _T) = 2.5V	4.5	7.5	9.5	mA
	RAMP 1 Discharge Current			5		mA
REFERENCE						
	Output Voltage	T _A = 25°C, I(V _{REF}) = 1mA	7.4	7.5	7.6	V
	Line Regulation	V _{CCZ} - 3V < V _{CC} < V _{CCZ} - 0.5V		2	10	mV
	Load Regulation	1mA < I(V _{REF}) < 20mA		7	20	mV
	Total Variation	Line, Load, Temp	7.25		7.65	V
	Long Term Stability	T _J = 125°C, 1000 Hours		5	25	mV

ELECTRICAL CHARACTERISTICS (Continued)

SYMBOL	PARAMETER	CONDITIONS	MIN	TYP	MAX	UNITS
PFC						
	Minimum Duty Cycle	ML4826-1, $V_{IEAO} > 4.0V$			0	%
		ML4826-2, $V_{IEAO} > 5.7V$			0	%
	Maximum Duty Cycle	$V_{IEAO} < 1.2V$	90	95		%
	Output Low Voltage	$I_{OUT} = -20mA$		0.4	0.8	V
		$I_{OUT} = -50mA$		0.6	3.0	V
		$I_{OUT} = 10mA, V_{CC} = 8V$		0.7	1.5	V
	Output High Voltage	$I_{OUT} = 20mA$	9.5	10.5		V
		$I_{OUT} = 50mA$	9.0	10		V
	Rise/Fall Time	$C_L = 1000pF$		50		ns
PWM						
	Duty Cycle Range		0-47	0-48	0-50	%
	Output Low Voltage	$I_{OUT} = -20mA$		0.4	0.8	V
		$I_{OUT} = -50mA$		0.6	3.0	V
		$I_{OUT} = 10mA, V_{CC} = 8V$		0.7	1.5	V
	Output High Voltage	$I_{OUT} = 20mA$	9.5	10.5		V
		$I_{OUT} = 50mA$	9.0	10		V
	Rise/Fall Time	$C_L = 1000pF$		50		ns
SUPPLY						
	Shunt Regulator Voltage (V_{CCZ})		12.8	13.5	14.2	V
	V_{CCZ} Load Regulation	$25mA < I_{CC} < 55mA$		± 150	± 300	mV
	V_{CCZ} Total Variation	Load, temp	12.4		14.6	V
	Start-up Current	$V_{CC} = 11.2V, C_L = 0$		0.7	1.1	mA
	Operating Current	$V_{CC} < V_{CCZ} - 0.5V, C_L = 0$		22	28	mA
	Undervoltage Lockout Threshold		12	13	14	V
	Undervoltage Lockout Hysteresis		2.65	3.0	3.35	V

Note 1: Limits are guaranteed by 100% testing, sampling, or correlation with worst-case test conditions.

Note 2: Includes all bias currents to other circuits connected to the V_{FB} pin.

Note 3: Gain = $K \times 5.3V$; $K = (I_{GAINMOD} - I_{OFFSET}) \times I_{AC} \times (V_{EAO} - 1.5V)^{-1}$.

TYPICAL PERFORMANCE CHARACTERISTICS

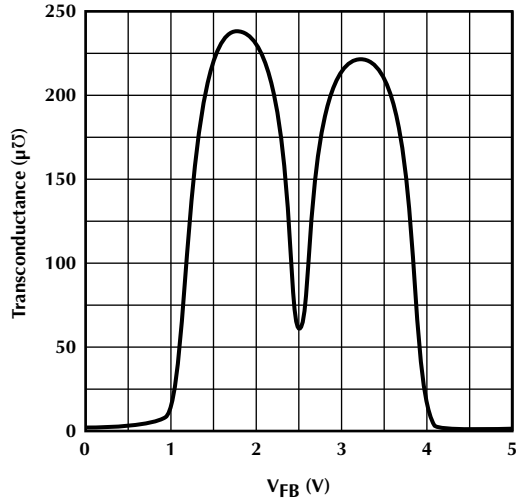

Voltage Error Amplifier (VEA) Transconductance (g_m)

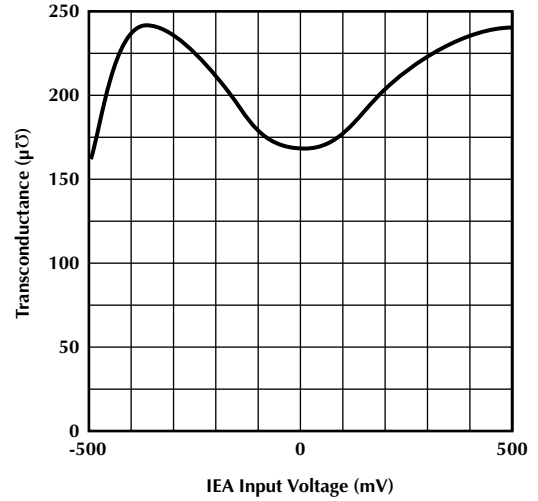

Current Error Amplifier (IEA) Transconductance (g_m)

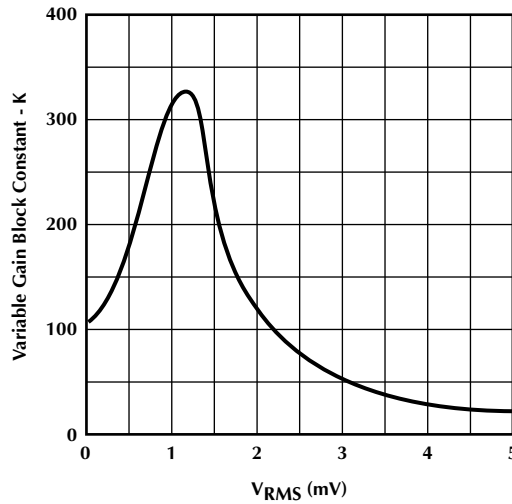

Variable Gain Control Transfer Characteristic

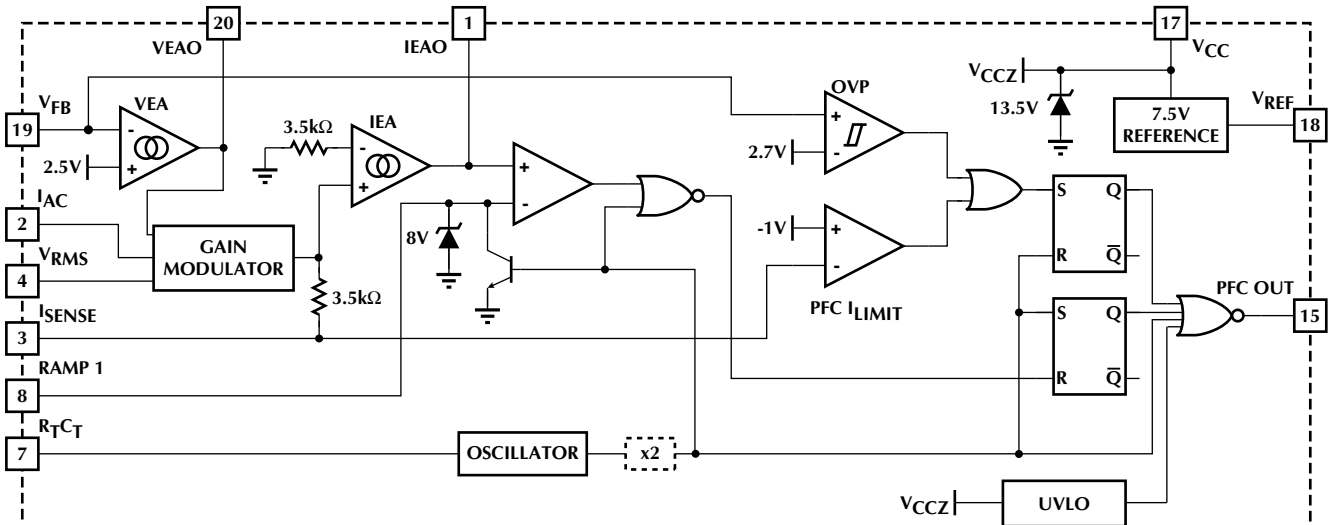

Figure 1. PFC Section Block Diagram.

FUNCTIONAL DESCRIPTION

The ML4826 consists of an average current controlled, continuous boost Power Factor Corrector (PFC) front end and a synchronized Pulse Width Modulator (PWM) back end. The PWM can be used in either current or voltage mode. In voltage mode, feedforward from the PFC output buss can be used to improve the PWM's line regulation. In either mode, the PWM stage uses conventional trailing-edge duty cycle modulation, while the PFC uses leading-edge modulation. This patented leading/trailing edge modulation technique results in a higher useable PFC error amplifier bandwidth, and can significantly reduce the size of the PFC DC buss capacitor.

The synchronization of the PWM with the PFC simplifies the PWM compensation due to the controlled ripple on the PFC output capacitor (the PWM input capacitor). The PWM section of the ML4826-1 runs at the same frequency as the PFC. The PWM section of the ML4826-2 runs at twice the frequency of the PFC, which allows the use of smaller PWM output magnetics and filter capacitors while holding down the losses in the PFC stage power components.

In addition to power factor correction, a number of protection features have been built into the ML4826. These include soft-start, PFC over-voltage protection, peak current limiting, brown-out protection, duty cycle limit, and under-voltage lockout.

POWER FACTOR CORRECTION

Power factor correction makes a non-linear load look like a resistive load to the AC line. For a resistor, the current drawn from the line is in phase with, and proportional to, the line voltage, so the power factor is unity (one). A common class of non-linear load is the input of a most power supplies, which use a bridge rectifier and capacitive input filter fed from the line. The peak-charging effect which occurs on the input filter capacitor in such a supply causes brief high-amplitude pulses of current to flow from the power line, rather than a sinusoidal current in phase with the line voltage. Such a supply presents a power factor to the line of less than one (another way to state this is that it causes significant current harmonics to appear at its input). If the input current drawn by such a supply (or any other non-linear load) can be made to follow the input voltage in instantaneous amplitude, it will appear resistive to the AC line and a unity power factor will be achieved.

To hold the input current draw of a device drawing power from the AC line in phase with, and proportional to, the input voltage, a way must be found to prevent that device from loading the line except in proportion to the instantaneous line voltage. The PFC section of the ML4826 uses a boost-mode DC-DC converter to accomplish this. The input to the converter is the full wave rectified AC line voltage. No filtering is applied following the bridge rectifier, so the input voltage to the boost converter ranges, at twice line frequency, from zero volts to the peak value of the AC input and back to zero. By forcing the boost converter to meet two simultaneous

conditions, it is possible to ensure that the current which the converter draws from the power line agrees with the instantaneous line voltage. One of these conditions is that the output voltage of the boost converter must be set higher than the peak value of the line voltage. A commonly used value is 385VDC, to allow for a high line of 270VAC_{rms}. The other condition is that the current which the converter is allowed to draw from the line at any given instant must be proportional to the line voltage. The first of these requirements is satisfied by establishing a suitable voltage control loop for the converter, which in turn drives a current error amplifier and switching output driver. The second requirement is met by using the rectified AC line voltage to modulate the output of the voltage control loop. Such modulation causes the current error amplifier to command a power stage current which varies directly with the input voltage. In order to prevent ripple which will necessarily appear at the output of the boost circuit (typically about 10VAC on a 385V DC level) from introducing distortion back through the voltage error amplifier, the bandwidth of the voltage loop is deliberately kept low. A final refinement is to adjust the overall gain of the PFC such to be proportional to $1/V_{IN}^2$, which linearizes the transfer function of the system as the AC input voltage varies.

Since the boost converter topology in the ML4826 PFC is of the current-averaging type, no slope compensation is required.

PFC SECTION

Gain Modulator

Figure 1 shows a block diagram of the PFC section of the ML4826. The gain modulator is the heart of the PFC, as it is this circuit block which controls the response of the current loop to line voltage waveform and frequency, rms line voltage, and PFC output voltage. There are three inputs to the gain modulator. These are:

- 1) A current representing the instantaneous input voltage (amplitude and waveshape) to the PFC. The rectified AC input sine wave is converted to a proportional current via a resistor and is then fed into the gain modulator at I_{AC} . Sampling current in this way minimizes ground noise, as is required in high power switching power conversion environments. The gain modulator responds linearly to this current.
- 2) A voltage proportional to the long-term rms AC line voltage, derived from the rectified line voltage after scaling and filtering. This signal is presented to the gain modulator at V_{RMS} . The gain modulator's output is inversely proportional to V_{RMS}^2 (except at unusually low values of V_{RMS} where special gain contouring takes over to limit power dissipation of the circuit components under heavy brown-out conditions). The relationship between V_{RMS} and gain is designated as K , and is illustrated in the Typical Performance Characteristics.

FUNCTIONAL DESCRIPTION (Continued)

3) The output of the voltage error amplifier, VEAO. The gain modulator responds linearly to variations in this voltage.

The output of the gain modulator is a current signal, in the form of a full wave rectified sinusoid at twice the line frequency. This current is applied to the virtual-ground (negative) input of the current error amplifier. In this way the gain modulator forms the reference for the current error loop, and ultimately controls the instantaneous current draw of the PFC from the power line. The general form for the output of the gain modulator is:

$$I_{\text{GAINMOD}} \cong \frac{I_{\text{AC}} \times \text{VEAO}}{V_{\text{RMS}}^2} \times 1\text{V}$$

More exactly, the output current of the gain modulator is given by:

$$I_{\text{GAINMOD}} \cong K \times (\text{VEAO} - 1.5\text{V}) \times I_{\text{AC}} \quad (1)$$

where K is in units of V⁻¹.

Note that the output current of the gain modulator is limited to $\cong 200\mu\text{A}$.

Current Error Amplifier

The current error amplifier's output controls the PFC duty cycle to keep the current through the boost inductor a linear function of the line voltage. At the inverting input to the current error amplifier, the output current of the gain modulator is summed with a current which results from a negative voltage being impressed upon the I_{SENSE} pin (current into I_{SENSE} $\cong V_{\text{SENSE}}/3.5\text{k}\Omega$). The negative voltage on I_{SENSE} represents the sum of all currents flowing in the PFC circuit, and is typically derived from a current sense resistor in series with the negative terminal of the input bridge rectifier. In higher power applications, two current transformers are sometimes used, one to monitor the I_D of the boost MOSFET(s) and one to monitor the I_F of the boost diode. As stated above, the inverting input of the current error amplifier is a virtual ground. Given this fact, and the arrangement of the duty cycle modulator polarities internal to the PFC, an increase in positive current from the gain modulator will cause the output stage to increase its duty cycle until the voltage on I_{SENSE} is adequately negative to cancel this increased current. Similarly, if the gain modulator's output decreases, the output duty cycle will decrease, to achieve a less negative voltage on the I_{SENSE} pin.

There is a modest degree of gain contouring applied to the transfer characteristic of the current error amplifier, to increase its speed of response to current-loop perturbations. However, the boost inductor will usually be

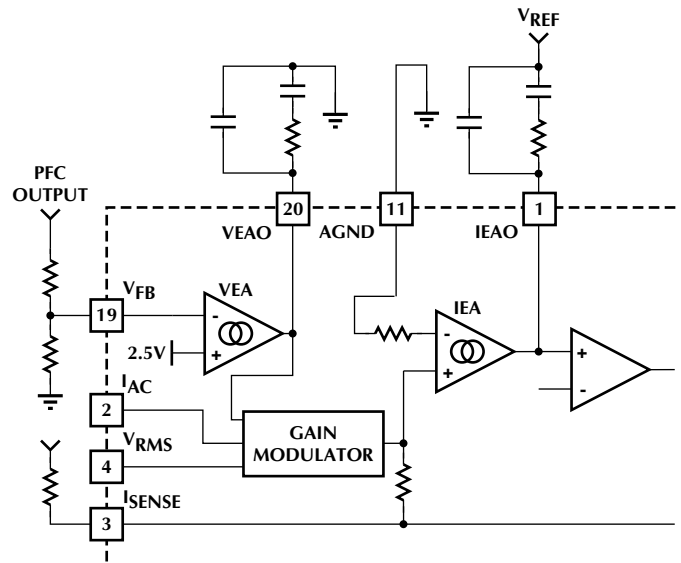

Figure 2. Compensation Network Connections for the Voltage and Current Error Amplifiers

the dominant factor in overall current loop response. Therefore, this contouring is significantly less marked than that of the voltage error amplifier. This is illustrated in the Typical Performance Characteristics.

Cycle-By-Cycle Current Limiter

The I_{SENSE} pin, as well as being a part of the current feedback loop, is a direct input to the cycle-by-cycle current limiter for the PFC section. Should the input voltage at this pin ever be more negative than -1V, the output of the PFC will be disabled until the protection flip-flop is reset by the clock pulse at the start of the next PFC power cycle.

Overvoltage Protection

The OVP comparator serves to protect the power circuit from being subjected to excessive voltages if the load should suddenly change. A resistor divider from the high voltage DC output of the PFC is fed to V_{FB}. When the voltage on V_{FB} exceeds 2.7V, the PFC output driver is shut down. The PWM section will continue to operate. The OVP comparator has 125mV of hysteresis, and the PFC will not restart until the voltage at V_{FB} drops below 2.58V. The V_{FB} should be set at a level where the active and passive external power components and the ML4826 are within their safe operating voltages, but not so low as to interfere with the boost voltage regulation loop.

FUNCTIONAL DESCRIPTION (Continued)

Error Amplifier Compensation

The PWM loading of the PFC can be modeled as a negative resistor; an increase in input voltage to the PWM causes a decrease in the input current. This response dictates the proper compensation of the two transconductance error amplifiers. Figure 3 shows the types of compensation networks most commonly used for the voltage and current error amplifiers, along with their respective return points. The current loop compensation is returned to V_{REF} to produce a soft-start characteristic on the PFC: as the reference voltage comes up from zero volts, it creates a differentiated voltage on IEAO which prevents the PFC from immediately demanding a full duty cycle on its boost converter.

There are two major concerns when compensating the voltage loop error amplifier; stability and transient response. Optimizing interaction between transient response and stability requires that the error amplifier's open-loop crossover frequency should be 1/2 that of the line frequency, or 23Hz for a 47Hz line (lowest anticipated international power frequency). The gain vs. input voltage of the ML4826's voltage error amplifier has a specially shaped nonlinearity such that under steady-state operating conditions the transconductance of the error amplifier is at a local minimum. Rapid perturbations in line or load conditions will cause the input to the voltage error amplifier (V_{FB}) to deviate from its 2.5V (nominal) value. If this happens, the transconductance of the voltage error amplifier will increase significantly, as shown in the Typical Performance Characteristics. This increases the gain-bandwidth product of the voltage loop, resulting in a much more rapid voltage loop response to such perturbations than would occur with a conventional linear gain characteristic.

The current amplifier compensation is similar to that of the voltage error amplifier with the exception of the choice of crossover frequency. The crossover frequency of the current amplifier should be at least 10 times that of the voltage amplifier, to prevent interaction with the voltage loop. It should also be limited to less than 1/6th that of the switching frequency, e.g. 16.7kHz for a 100kHz switching frequency.

For more information on compensating the current and voltage control loops, see Application Notes 33 and 34. Application Note 16 also contains valuable information for the design of this class of PFC.

Main Oscillator ($R_T C_T$)

The oscillator frequency is determined by the values of R_T and C_T , which determine the ramp and off-time of the oscillator output clock:

$$f_{OSC} = \frac{1}{t_{RAMP} + t_{DEADTIME}} \quad (2)$$

The deadtime of the oscillator is derived from the following equation:

$$t_{DEADTIME} = \frac{2.5V}{5.1mA} \times C_T = 490 \times C_T \quad (3)$$

at $V_{REF} = 7.5V$:

$$t_{RAMP} = C_T \times R_T \times 0.51$$

The ramp of the oscillator may be determined using:

$$t_{RAMP} = C_T \times R_T \times \ln\left(\frac{V_{REF} - 1.25}{V_{REF} - 3.75}\right) \quad (4)$$

The deadtime is so small ($t_{RAMP} \gg t_{DEADTIME}$) that the operating frequency can typically be approximated by:

$$f_{OSC} = \frac{1}{t_{RAMP}} \quad (5)$$

For proper reset of internal circuits during dead time, values of 1000pF or greater are suggested for C_T .

EXAMPLE:

For the application circuit shown in the data sheet, with the oscillator running at:

$$f_{OSC} = 200kHz = \frac{1}{t_{RAMP}}$$

$$t_{RAMP} = C_T \times R_T \times 0.51 = 1 \times 10^{-5}$$

Solving for $R_T \times C_T$ yields 2×10^{-4} . Selecting standard components values, $C_T = 1000pF$, and $R_T = 8.63k\Omega$.

The deadtime of the oscillator adds to the Maximum PWM Duty Cycle (it is an input to the Duty Cycle Limiter). With zero oscillator deadtime, the Maximum PWM Duty Cycle is typically 45%. In many applications, care should be taken that C_T not be made so large as to extend the Maximum Duty Cycle beyond 50%.

FUNCTIONAL DESCRIPTION (Continued)

PFC RAMP (RAMP1)

The intersection of RAMP1 and the boost current error amplifier output controls the PFC pulse width. RAMP1 can be generated in a similar fashion to the $R_T C_T$ ramp.

The current error amplifier maximum output voltage has a minimum of 6V. The peak value of RAMP1 should not exceed that voltage. Assuming a maximum voltage of 5V for RAMP1, Equation 6 describes the RAMP1 time. With a 100kHz PFC frequency, the resistor tied to V_{REF} , and a 150pF capacitor, Equation 7 solves for the RAMP1 resistor.

$$t_{RAMP1} = C_{RAMP1} \times R_{RAMP1} \times \ln \left\{ \frac{V_{REF}}{V_{REF} - 5V} \right\} \quad (6)$$

$$= 1.1 \times R_{RAMP1} \times C_{RAMP1}$$

$$R_{RAMP1} = \frac{t_{RAMP1}}{1.1 \times C_{RAMP1}} = \frac{10\mu s}{1.1 \times 150pF} = 60k\Omega \quad (7)$$

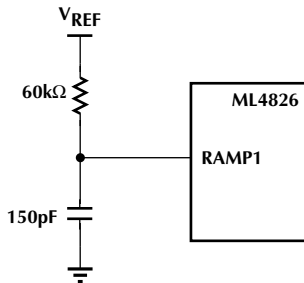

Figure 3.

PMW SECTION

Pulse Width Modulator

The PWM section of the ML4826 is straightforward, but there are several points which should be noted. Foremost among these is its inherent synchronization to the PFC section of the device, from which it also derives its basic timing (at the PFC frequency in the ML4826-1, and at twice the PFC frequency in the ML4826-2). The PWM is capable of current-mode or voltage mode operation. In current-mode applications, the PWM ramp (RAMP2) is usually derived directly from a current sensing resistor or current transformer in the primary of the output stage, and is thereby representative of the current flowing in the converter's output stage. DC I_{LIMIT} , which provides cycle-by-cycle current limiting, is typically connected to RAMP2 in such applications. For voltage-mode operation or certain specialized applications, RAMP2 can be

connected to a separate RC timing network to generate a voltage ramp against which V_{DC} will be compared. Under these conditions, the use of voltage feedforward from the PFC buss can assist in line regulation accuracy and response. As in current mode operation, the DC I_{LIMIT} input would be used for output stage overcurrent protection.

No voltage error amplifier is included in the PWM stage of the ML4826, as this function is generally performed on the output side of the PWM's isolation boundary. To facilitate the design of optocoupler feedback circuitry, an offset has been built into the PWM's RAMP2 input which allows V_{DC} to command a zero percent duty cycle for input voltages below 1.5V.

PWM Current Limit

The DC I_{LIMIT} pin is a direct input to the cycle-by-cycle current limiter for the PWM section. Should the input voltage at this pin ever exceed 1V, the output of the PWM will be disabled until the output flip-flop is reset by the clock pulse at the start of the next PWM power cycle.

V_{IN} OK Comparator

The V_{IN} OK comparator monitors the DC output of the PFC and inhibits the PWM if this voltage on V_{FB} is less than its nominal 2.5V. Once this voltage reaches 2.5V, which corresponds to the PFC output capacitor being charged to its rated boost voltage, the soft-start commences.

RAMP2

The RAMP2 input is compared to the feedback voltage (V_{DC}) to set the PWM pulse width. In voltage mode it can be generated using the same method used for the $R_T C_T$ input. In current mode the primary current sense and slope compensation are fed into the RAMP2 input.

Peak current mode control with duty cycles greater than 50% requires slope compensation for stability. Figure 4 displays the method used for the required slope compensation. The example shown adds the slope compensation signal to the current sense signal. Alternatively, the slope compensation signal can also be subtracted from the feedback signal (V_{DC}).

In setting up the slope compensation first determine the down slope in the output inductor current. To determine the actual signal required at the RAMP2 input, reflect 1/2 of the inductor downslope through the main transformer, current sense transformer to the ramp input.

Internal to the IC is a 1.5V offset in series with the RAMP2 input. In the example show the positive input to the PWM comparator is developed from V_{REF} (7.5V), this limits the RAMP2 input (current sense and slope compensation) to 6

FUNCTIONAL DESCRIPTION (Continued)

Volts peak. The composite waveform feeding the RAMP2 pin for the PWM consists of the reflected output current signal along with the transformer magnetizing current and the slope compensation signal.

Equation 8 describes the composite signal feeding RAMP2, consisting of the primary current of the main transformer and the slope compensation. Equation 9 solves for the required slope compensation peak voltage.

$$V_{\text{RAMP2}} = \left\{ I_{\text{PRI}} + \frac{1}{2} \times \frac{V_{\text{OUT}}}{L} \times \frac{N_s}{N_p} \times T_s \right\} \times \frac{1}{n_{\text{CT}}} \leq V_{\text{FB}} - 1.5\text{V} \quad (8)$$

$$V_{\text{SC}} = \left\{ \frac{1}{2} \times \frac{V_{\text{OUT}}}{L} \times \frac{N_s}{N_p} \right\} \times \frac{R_{\text{SENSE}}}{n_{\text{CT}}} = \frac{1}{2} \times \frac{48\text{V}}{20\mu\text{H}} \times \frac{14}{90} \times 5\mu\text{sec} \times \frac{47\text{k}\Omega}{200} = 2.2\text{V} \quad (9)$$

Soft Start

Start-up of the PWM is controlled by the selection of the external capacitor at SS. A current source of 50 μA supplies the charging current for the capacitor, and start-up of the PWM begins at 1.5V. Start-up delay can be programmed by the following equation:

$$C_{\text{SS}} = t_{\text{DELAY}} \times \frac{50\mu\text{A}}{1.5\text{V}} \quad (10)$$

where C_{SS} is the required soft start capacitance, and t_{DELAY} is the desired start-up delay.

It is important that the time constant of the PWM soft-start allow the PFC time to generate sufficient output power for the PWM section. The PWM start-up delay should be at least 5ms.

Solving for the minimum value of C_{SS} :

$$C_{\text{SS}} = 5\text{ms} \times \frac{50\mu\text{A}}{1.5\text{V}} = 167\text{nF} \quad (11)$$

V_{CC}

The ML4826 is a current-fed part. It has an internal shunt voltage regulator, which is designed to regulate the voltage internal to the part at 13.5V. This allows a low power dissipation while at the same time delivering 10V of gate drive at the PWM OUT and PFC OUT outputs. It is important to limit the current through the part to avoid overheating or destroying the part.

There are a number of different ways to supply V_{CC} to the ML4826. The method suggested in Figure 5, is one which keeps the ML4826 I_{CC} current to a minimum, and allows for a loosely regulated bootstrap winding. By feeding external gate drive components from the base of Q1, the constant current source does not have to account for variations in the gate drive current. This helps to keep the maximum I_{CC} of the ML4826 to a minimum. Also, the current available to charge the bootstrap capacitor from the bootstrap winding is not limited by the constant

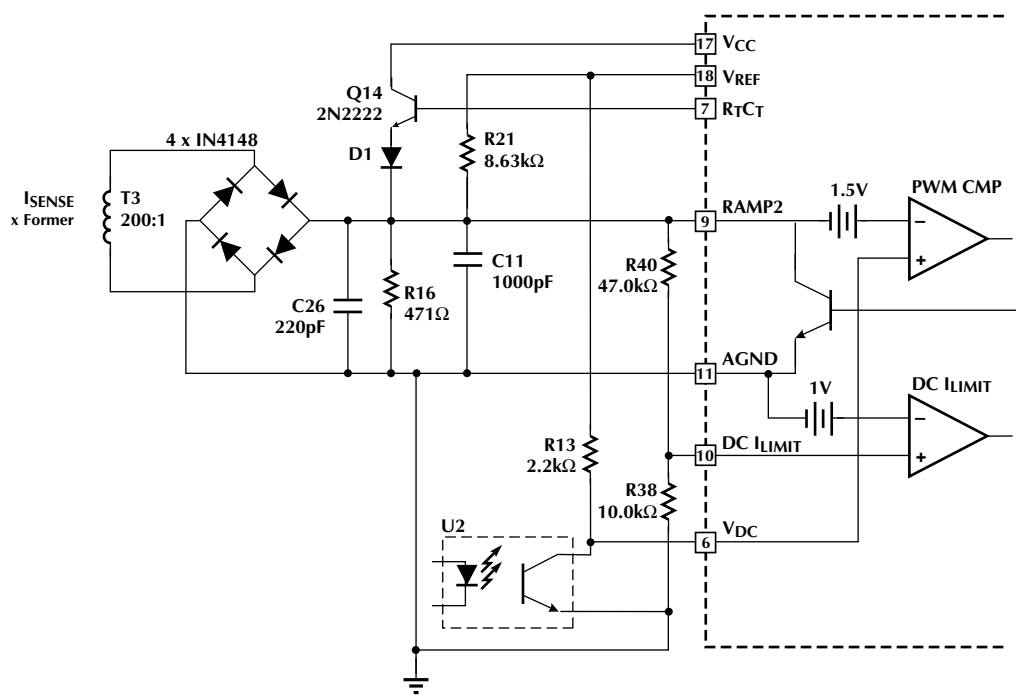

Figure 4. Slope Compensation and Current Sense

FUNCTIONAL DESCRIPTION (Continued)

current source. The circuit guarantees that the maximum operating current is available at all times and minimizes the worst case power dissipation in the IC.

Other methods such as a simple series resistor are possible, but can very easily lead to excessive I_{CC} current in the ML4826. Figures 6 and 7 show other possible methods for feeding V_{CC} .

LEADING/TRAILING MODULATION

Conventional Pulse Width Modulation (PWM) techniques employ trailing edge modulation in which the switch will turn on right after the trailing edge of the system clock. The error amplifier output voltage is then compared with the modulating ramp. When the modulating ramp reaches the level of the error amplifier output voltage, the switch will be turned OFF. When the switch is ON, the inductor current will ramp up. The effective duty cycle of the

trailing edge modulation is determined during the ON time of the switch. Figure 4 shows a typical trailing edge control scheme.

In the case of leading edge modulation, the switch is turned OFF right at the leading edge of the system clock. When the modulating ramp reaches the level of the error amplifier output voltage, the switch will be turned ON. The effective duty-cycle of the leading edge modulation is determined during the OFF time of the switch. Figure 5 shows a leading edge control scheme.

One of the advantages of this control technique is that it requires only one system clock. Switch 1 (SW1) turns off and switch 2 (SW2) turns on at the same instant to minimize the momentary “no-load” period, thus lowering ripple voltage generated by the switching action. With such synchronized switching, the ripple voltage of the first stage is reduced. Calculation and evaluation have shown that the 120Hz component of the PFC’s output ripple voltage can be reduced by as much as 30% using this method.

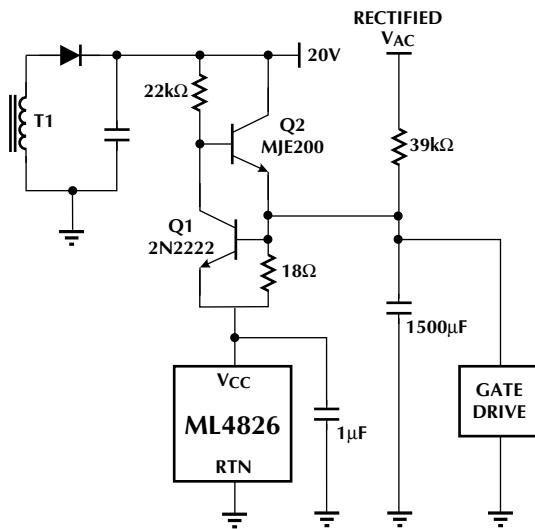

Figure 5. V_{CC} Bias Circuitry

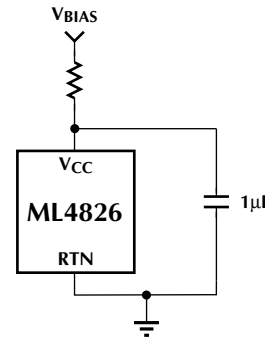

Figure 6.

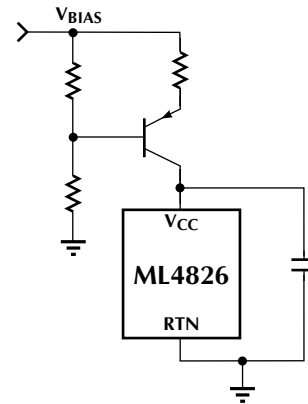

Figure 7.

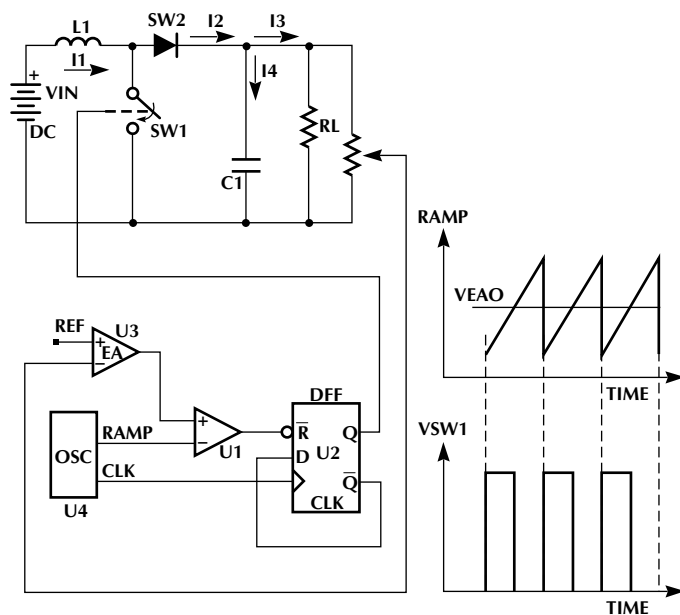

Figure 8. Typical Trailing Edge Control Scheme.

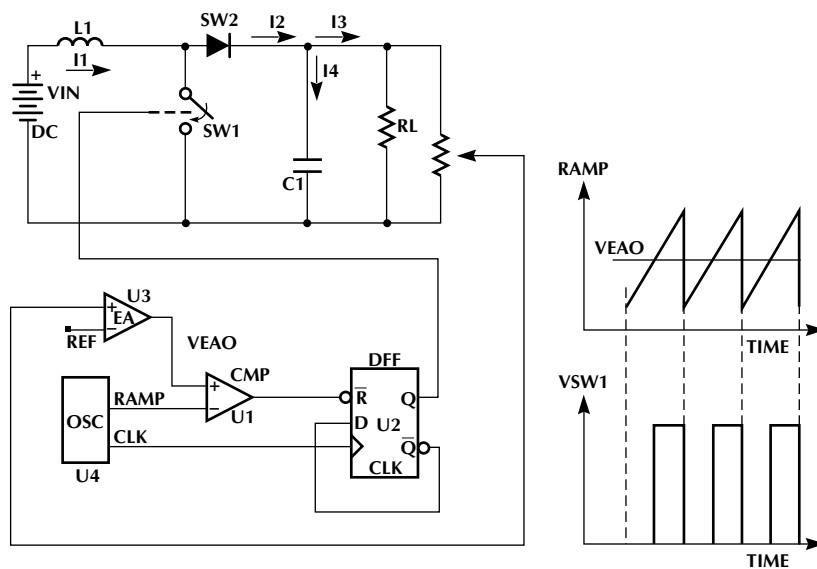

Figure 8. Typical Leading Edge Control Scheme.

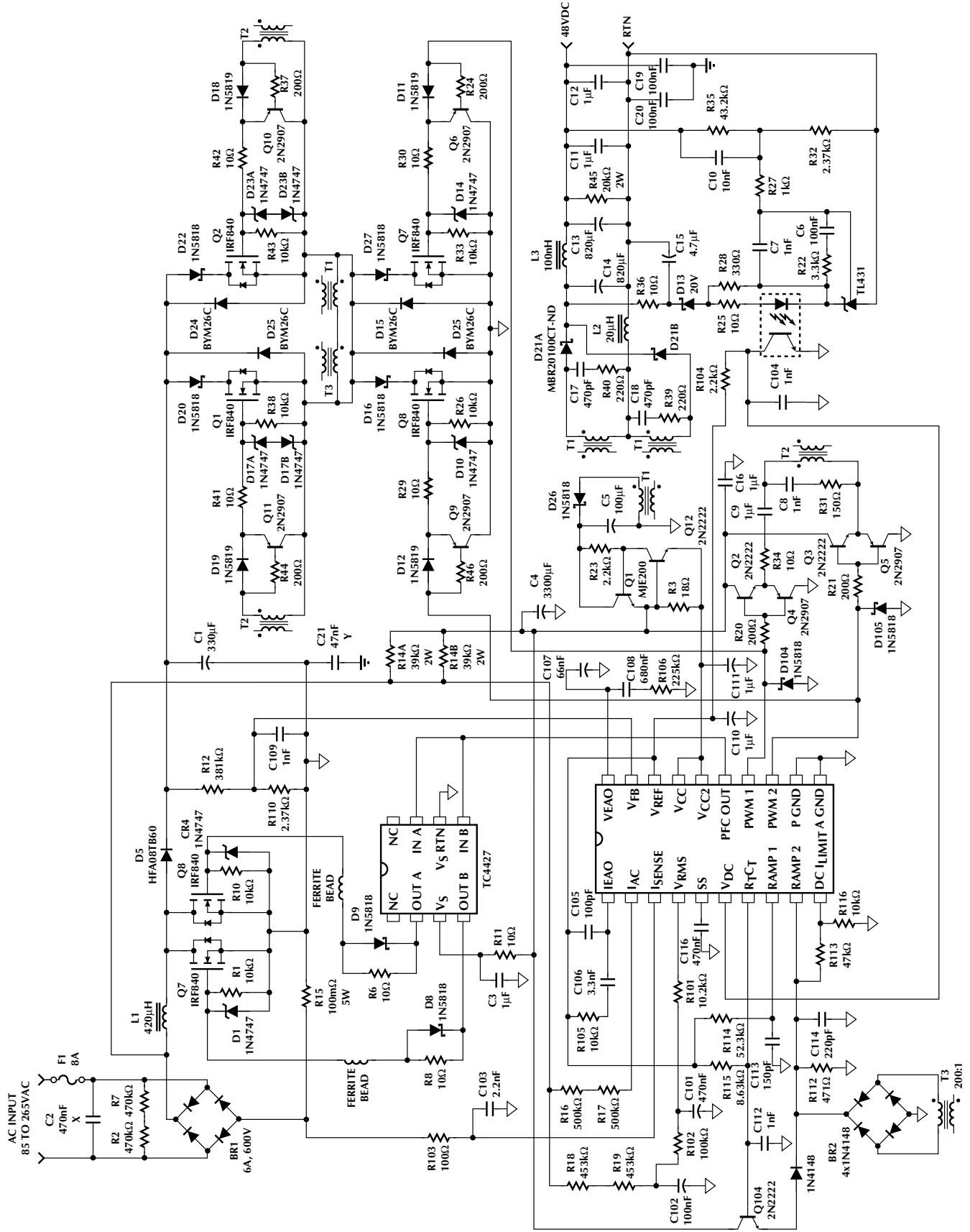
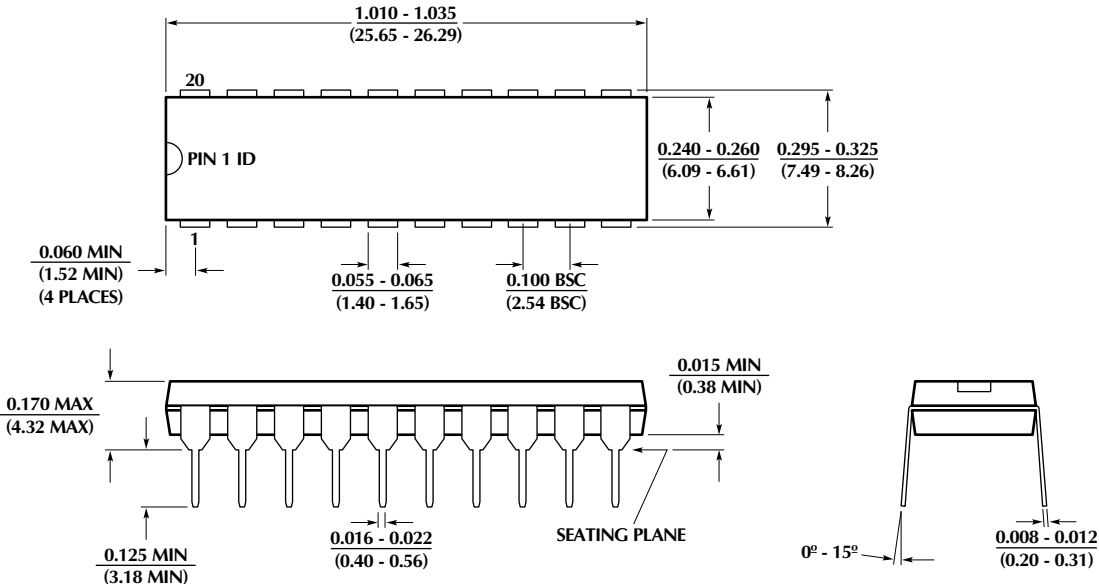

Figure 10. 48V 300W Power Factor Corrected Power Supply

PHYSICAL DIMENSIONS inches (millimeters)

Package: P20
20-Pin PDIP



Package: S20
20-Pin SOIC

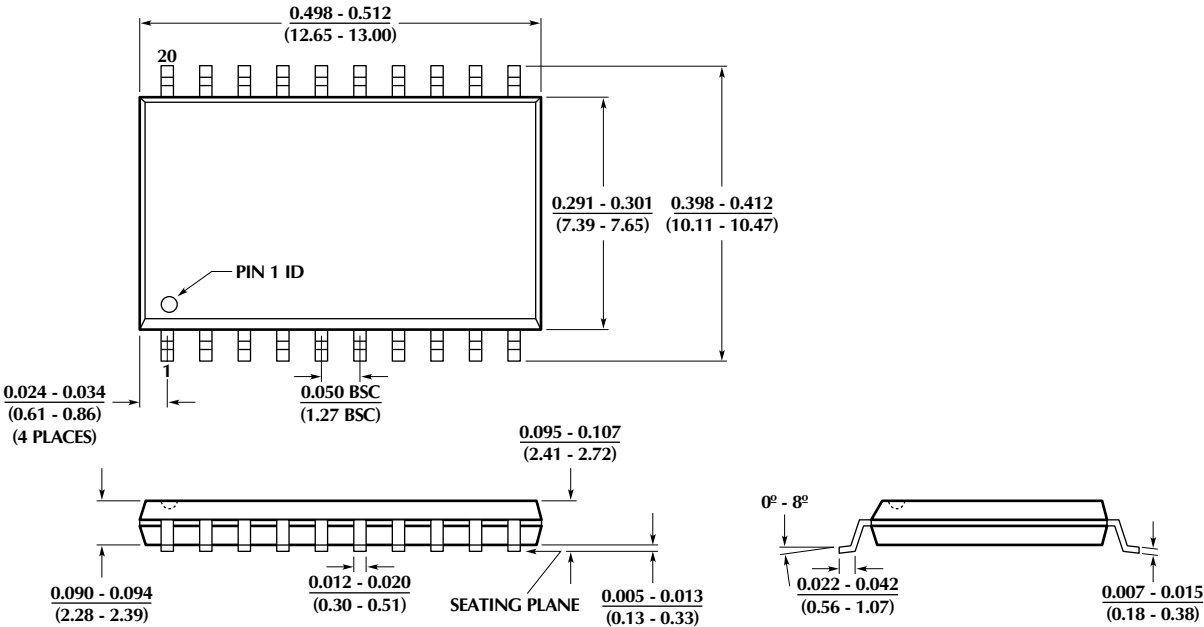

ORDERING INFORMATION

PART NUMBER	PWM FREQUENCY	TEMPERATURE RANGE	PACKAGE
ML4826CP-1	1 x PFC	0°C to 70°C	20-Pin PDIP (P20) (Obsolete)
ML4826CP-2	2 x PFC	0°C to 70°C	20-Pin PDIP (P20) (EOL)
ML4826CS-1	1 x PFC	0°C to 70°C	20-Pin SOIC (S20) (Obsolete)
ML4826CS-2	2 x PFC	0°C to 70°C	20-Pin SOIC (S20) (EOL)
ML4826IP-1	1 x PFC	-40°C to 85°C	20-Pin PDIP (P20)(Obsolete)
ML4826IP-2	2 x PFC	-40°C to 85°C	20-Pin PDIP (P20) (Obsolete)
ML4826IS-1	1 x PFC	-40°C to 85°C	20-Pin SOIC (S20) (Obsolete)
ML4826IS-2	2 x PFC	-40°C to 85°C	20-Pin SOIC (S20) (Obsolete)

© Micro Linear 1997  **Micro Linear** is a registered trademark of Micro Linear Corporation
 Products described in this document may be covered by one or more of the following patents, U.S.: 4,897,611; 4,964,026; 5,027,116; 5,281,862; 5,283,483; 5,418,502; 5,508,570; 5,510,727; 5,523,940; 5,546,017; 5,559,470; 5,565,761; 5,592,128; 5,594,376; Japan: 2598946; 2619299. Other patents are pending.

Micro Linear reserves the right to make changes to any product herein to improve reliability, function or design. Micro Linear does not assume any liability arising out of the application or use of any product described herein, neither does it convey any license under its patent right nor the rights of others. The circuits contained in this data sheet are offered as possible applications only. Micro Linear makes no warranties or representations as to whether the illustrated circuits infringe any intellectual property rights of others, and will accept no responsibility or liability for use of any application herein. The customer is urged to consult with appropriate legal counsel before deciding on a particular application.

2092 Concourse Drive
 San Jose, CA 95131
 Tel: 408/433-5200
 Fax: 408/432-0295