

Electronic Ballast Controller

GENERAL DESCRIPTION

The ML4831 is a complete solution for a dimmable, high power factor, high efficiency electronic ballast. Contained in the ML4831 are controllers for “boost” type power factor correction as well as for a dimming ballast.

The Power factor circuit uses the average current sensing method with a gain modulator and over-voltage protection. This system produces power factors of better than 0.99 with low input current THD at > 95% efficiency. Special care has been taken in the design of the ML4831 to increase system noise immunity by using a high amplitude oscillator, and a current fed multiplier. An over-voltage protection comparator inhibits the PFC section in the event of a lamp out or lamp failure condition.

The ballast section provides for programmable starting scenarios with programmable preheat and lamp out-of-socket interrupt times. The IC controls lamp output through either frequency modulation using lamp current feedback.

The ML4831 is designed using Micro Linear’s Semi-Standard tile array technology. Customized versions of this IC, optimized to specific ballast architectures can be made available. Contact Micro Linear or an authorized representative for more information.

FEATURES

- Complete Power Factor Correction and Dimming Ballast Control on one IC
- Low Distortion, High Efficiency Continuous Boost, Average Current sensing PFC section
- Programmable Start Scenario for Rapid or Instant Start Lamps
- Lamp Current feedback for Dimming Control
- Variable Frequency dimming and starting
- Programmable Restart for lamp out condition to reduce ballast heating
- Over-Temperature Shutdown replaces external heat sensor for safety
- PFC Over-Voltage comparator eliminates output “runaway” due to load removal
- Large oscillator amplitude and gain modulator improves noise immunity

* This product is End Of Life as of July 1, 2000

BLOCK DIAGRAM

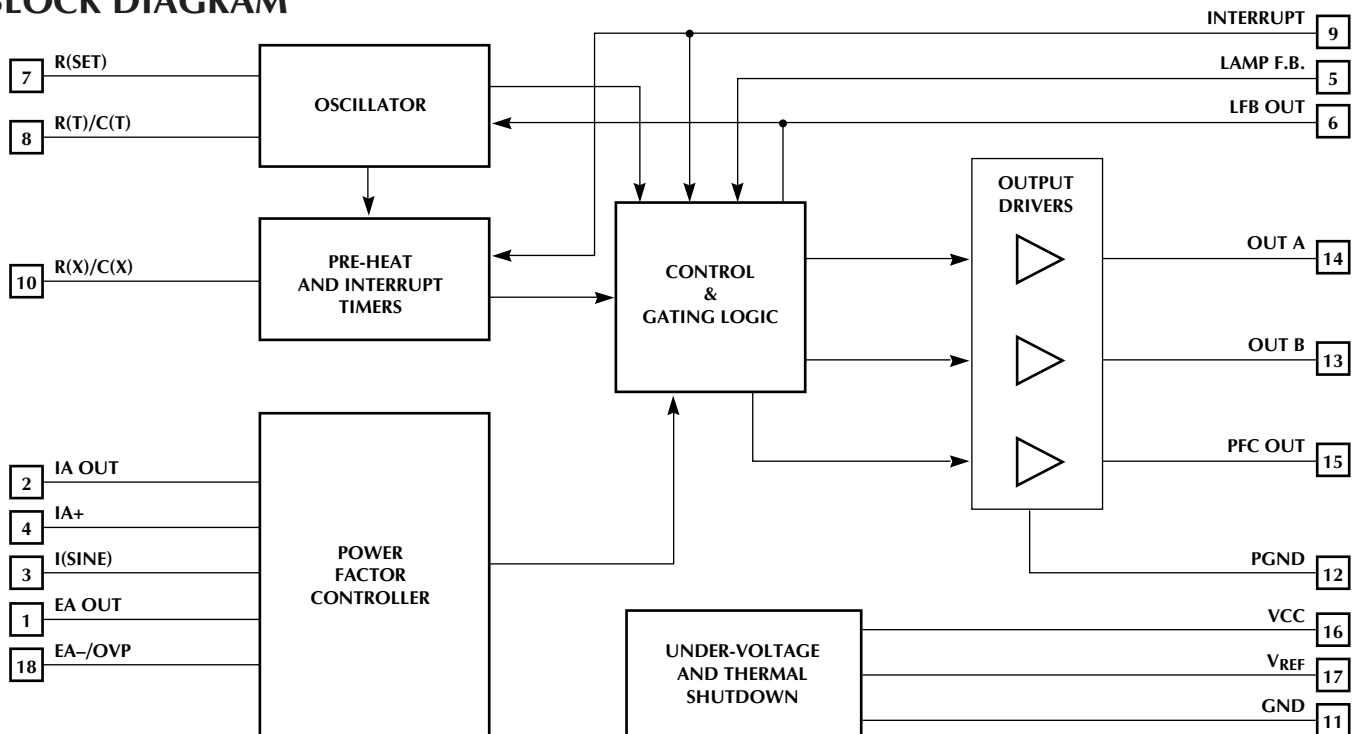

PIN CONFIGURATION

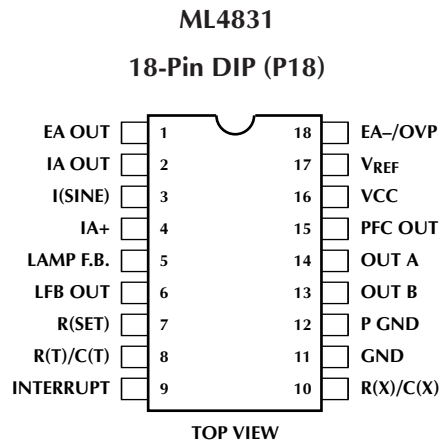

PIN DESCRIPTION

PIN#	NAME	FUNCTION	PIN#	NAME	FUNCTION
1	EA OUT	PFC Error Amplifier output and compensation node	8	R(T)/C(T)	Oscillator timing components
2	IA OUT	Output and compensation node of the PFC average current transconductance amplifier.	9	INTERRUPT	Input used for lamp-out detection and restart. A voltage greater than 7.5 volts resets the chip and causes a restart after a programmable interval.
3	I(SINE)	PFC gain modulator input.	10	R(X)/C(X)	Sets the timing for the preheat, dimming lockout, and interrupt
4	IA+	Non-inverting input of the PFC average current transconductance amplifier and peak current sense point of the PFC cycle by cycle current limit comparator.	11	GND	Ground
5	LAMP F.B.	Inverting input of an Error Amplifier used to sense (and regulate) lamp arc current. Also the input node for dimming control.	12	P GND	Power ground for the IC
6	LFB OUT	Output from the Lamp Current Error Transconductance Amplifier used for lamp current loop compensation	13	OUT B	Ballast MOSFET drive output
7	R(SET)	External resistor which sets oscillator F _{MAX} , and R(X)/C(X) charging current	14	OUT A	Ballast MOSFET drive output
			15	PFC OUT	Power Factor MOSFET drive output
			16	VCC	Positive Supply for the IC
			17	V _{REF}	Buffered output for the 7.5V voltage reference
			18	EA-/OVP	Inverting input to PFC error amplifier and OVP comparator input

ABSOLUTE MAXIMUM RATINGS

Absolute maximum ratings are those values beyond which the device could be permanently damaged. Absolute maximum ratings are stress ratings only and functional device operation is not implied.

Supply Current (I_{CC})	75mA
Output Current, Source or Sink (Pins 13, 14, 15) DC	250mA
Output Energy (capacitive load per cycle)	1.5 mJ
Gain Modulator I(SINE) Input (Pin 3)	10 mA
Analog Inputs (Pins 5, 9, 18)	-0.3V to VCC -2V
Pin 4 input voltage	-3V to 2V
Maximum Forced Voltage (Pins 1, 6)	-0.3V to 7.7V

Maximum Forced Current (Pins 1, 2, 6)	± 20 mA
Maximum Forced Voltage (Pin 2)	-0.3V to 6V
Junction Temperature	150°C
Storage Temperature	-65°C to 150°C
Lead Temperature (Soldering 10 Sec.)	260°C
Thermal Resistance (θ_{JA}) Plastic DIP-P	70°C/W

OPERATING CONDITIONS

Temperature Range ML4831C	0°C to 85°C
------------------------------------	-------------

ELECTRICAL CHARACTERISTICS

Unless otherwise specified, $R(\text{SET}) = 31.6\text{k}\Omega$, $R(\text{T}) = 16.2\text{k}\Omega$, $C(\text{T}) = 1.5\text{nF}$, T_J = Junction Operating Temperature Range, $I_{CC} = 25\text{mA}$

PARAMETER	CONDITIONS	MIN	TYP	MAX	UNITS
PFC Current Sense Amplifier (Pins 2, 4)					
Small Signal Transconductance		130	200	270	μmhos
Input Voltage Range		-0.3		3.5	V
Output Low	$I_{SINE} = 0\text{mA}$, $V_{PIN1} = 0\text{V}$, $V_{PIN4} = -0.3\text{V}$, $R_L = \infty$		0.2	0.4	V
Output High	$I_{SINE} = 1.5\text{mA}$, $V_{PIN18/4} = 0\text{V}$, $R_L = \infty$	5.2	5.6	6	V
Source Current	$I_{SINE} = 1.5\text{mA}$, $V_{PIN18/4} = 0\text{V}$, $V_{PIN2} = 5\text{V}$		-0.3		mA
Sink Current	$I_{SINE} = 0\text{mA}$, $V_{PIN2} = 0.3\text{V}$, $V_{PIN4} = -0.3\text{V}$, $V_{PIN1} = 0\text{V}$		0.3		mA
PFC Voltage Feedback Amplifier (Pins 1, 18)/Lamp Current Amplifier (Pins 5, 6)					
Input Offset Voltage			± 3.0	± 10.0	mV
Input Bias Current			-0.3	-1.0	μA
Small Signal Transconductance		50	80	110	μmhos
Input Voltage Range		-0.3		3.5	V
Output Low	$V_{PIN5/18} = 3\text{V}$, $R_L = \infty$		0.2	0.4	V
Output High	$V_{PIN5/18} = 2\text{V}$, $R_L = \infty$	7.2	7.5		V
Source Current	$V_{PIN5/18} = 0\text{V}$, $V_{PIN1/6} = 7\text{V}$		-0.2		mA
Sink Current	$V_{PIN5/18} = 5\text{V}$, $V_{PIN1/6} = 0.3\text{V}$		0.2		mA
Gain Modulator					
Output Voltage	$I_{SINE} = 100\mu\text{A}$, $V_{PIN1} = 3\text{V}$		40		mV
	$I_{SINE} = 300\mu\text{A}$, $V_{PIN1} = 3\text{V}$		130		mV
	$I_{SINE} = 100\mu\text{A}$, $V_{PIN1} = 6\text{V}$		112		mV
	$I_{SINE} = 300\mu\text{A}$, $V_{PIN1} = 6\text{V}$		350		mV
Output Voltage Limit	$I_{SINE} = 1.5\text{mA}$, $V_{PIN18} = 0\text{V}$		865		mV
Offset Voltage	$I_{SINE} = 0$, $V_{PIN18} = 0\text{V}$			15	mV
	$I_{SINE} = 150\mu\text{A}$, $V_{PIN18} = 3\text{V}$			15	mV
I(SINE) Input Voltage	$I_{SINE} = 200\mu\text{A}$	0.8	1.4	1.8	V

ELECTRICAL CHARACTERISTICS (Continued)

PARAMETER	CONDITIONS	MIN	TYP	MAX	UNITS
Oscillator					
Initial accuracy	$T_A = 25^\circ\text{C}$	72	76	80	kHz
Voltage stability	$V_{CCZ} - 3V < V_{CC} < V_{CCZ} - 0.5V$		1		%
Temperature stability			2		%
Total Variation	Line, temperature	69		83	kHz
Ramp Valley to Peak			2.5		V
C(T) Charging Current (FM Modes)	$V_{PIN5} = 3V, V_{PIN8} = 2.5V,$ $V_{PIN10} = 0.9V$ (Preheat)		-78		μA
	$V_{PIN5} = 3V, V_{PIN8} = 2.5V,$ $V_{PIN10} = \text{Open}$		-156		μA
C(T) Discharge Current	$V_{PIN8} = 2.5V$		5		mA
Output Drive Deadtime			0.75		μs
Reference Section					
Output Voltage	$T_A = 25^\circ\text{C}, I_O = 1\text{mA}$	7.4	7.5	7.6	V
Line regulation	$V_{CCZ} - 3V < V_{CC} < V_{CCZ} - 0.5V$		2	10	mV
Load regulation	$1\text{mA} < I_O < 20\text{mA}$		2	15	mV
Temperature stability			0.4		%
Total Variation	Line, load, temp	7.35		7.65	V
Output Noise Voltage	10Hz to 10KHz		50		μV
Long Term Stability	$T_J = 125^\circ\text{C}, 1000\text{ hrs}$		5		mV
Short Circuit Current	$V_{CC} < V_{CCZ} - 0.5V, V_{REF} = 0V$		-40		mA
Preheat and Interrupt Timer (Pin 10) (R(X) = 590KΩ, C(X) = 5.6μF)					
Initial Preheat Period			0.8		s
Subsequent Preheat Period			0.7		s
Start Period			2.1		s
Interrupt Period			6.3		s
Pin 10 Charging Current			-19		μA
Pin 10 Open Circuit Voltage	$V_{CC} = 12.3V$ in UVLO	0.4	0.9	1.1	V
Pin 10 Maximum Voltage		7.0	7.3	7.7	V
Input Bias Current	$V_{PIN10} = 1.2V$		-0.2		μA
Preheat Lower Threshold			1.18		V
Preheat Upper Threshold			3.36		V
Interrupt Recovery Threshold			1.18		V
Start Period End Threshold			6.7		V
Interrupt Input (Pin 9)					
Interrupt Threshold		7.35	7.5	7.65	V
Input Bias Current			-0.3	-1	μA

ELECTRICAL CHARACTERISTICS (Continued)

PARAMETER	CONDITIONS	MIN	TYP	MAX	UNITS
OVP Comparator (Pin 18)					
OVP Threshold		2.6	2.7	2.8	V
Hysteresis			0.25		V
Propagation Delay			500		ns
Outputs					
Output Voltage Low	I _{OUT} = 20mA		0.4	0.8	V
	I _{OUT} = 200mA		2.1	3.0	V
Output Voltage High	I _{OUT} = -20mA	V _{CC} - 2.5	V _{CC} - 1.9		V
	I _{OUT} = -200mA	V _{CC} - 3.0	V _{CC} - 2.2		V
Output Voltage Low in UVLO	I _{OUT} = 10mA, V _{CC} = 8V		0.8	1.5	V
Output Rise/Fall Time	C _L = 1000pF		50		ns
Under-Voltage Lockout and Bias Circuits					
IC Shunt Voltage (V _{CCZ})	I _{CC} = 25mA	12.8	13.5	14.2	V
V _{CCZ} Load Regulation	25mA < I _{CC} < 68mA		150	300	mV
V _{CCZ} Total Variation	Load, Temp	12.4		14.6	V
Start-up Current	V _{CC} ≤ 12.3V		1.3	1.7	mA
Operating Current	V _{CC} = V _{CCZ} - 0.5V		15	19	mA
Start-up Threshold			V _{CCZ} - 0.5		V
Shutdown Threshold			V _{CCZ} - 3.5		V
Shutdown Temperature (T _J)			120		°C
Hysteresis (T _J)			30		°C

FUNCTIONAL DESCRIPTION**OVERVIEW**

The ML4831 consists of an Average Current controlled continuous boost Power Factor front end section with a flexible ballast control section. Start-up and lamp-out retry timing are controlled by the selection of external timing components, allowing for control of a wide variety of different lamp types. The ballast section controls the lamp power using frequency modulation (FM) with additional programmability provided to adjust the VCO frequency range. This allows for the IC to be used with a variety of different output networks.

POWER FACTOR SECTION

The ML4831 Power Factor section is an average current sensing boost mode PFC control circuit which is architecturally similar to that found in the ML4821. For detailed information on this control architecture, please refer to Application Note 16 and the ML4821 data sheet.

GAIN MODULATOR

The ML4831 gain modulator provides high immunity to the disturbances caused by high power switching. The rectified line input sine wave is converted to a current via a dropping resistor. In this way, small amounts of ground noise produce an insignificant effect on the reference to the PWM comparator.

The output of the gain modulator appears on the positive terminal of the IA amplifier to form the reference for the current error amplifier. Please refer to Figure 1.

$$V_{MUL} \approx \frac{[I(SINE) \times (VEA - 1.1V)]}{4.17mA} \quad (1)$$

where: I(SINE) is the current in the dropping resistor,
V(EA) is the output of the error amplifier (Pin 1).

The output of the gain modulator is limited to 1.0V.

AVERAGE CURRENT AND OUTPUT VOLTAGE REGULATION

The PWM regulator in the PFC Control section will act to offset the positive voltage caused by the multiplier output by producing an offsetting negative voltage on the current sense resistor at Pin 4. A cycle-by-cycle current limit is included to protect the MOSFET from high speed current transients. When the voltage at Pin 4 goes negative by more than 1V, the PWM cycle is terminated.

For more information on compensating the average current and boost voltage error amplifier loops, see ML4821 data sheet.

OVERVOLTAGE PROTECTION AND INHIBIT

The OVP pin serves to protect the power circuit from being subjected to excessive voltages if the load should change suddenly (lamp removal). A divider from the high voltage DC bus sets the OVP trip level. When the voltage on Pin 18 exceeds 2.75V, the PFC transistors are inhibited. The ballast section will continue to operate. The OVP threshold should be set to a level where the power components are safe to operate, but not so low as to interfere with the boost voltage regulation loop.

TRANSCONDUCTANCE AMPLIFIERS

The PFC voltage feedback, PFC current sense, and the loop current amplifiers are all implemented as operational transconductance amplifiers. They are designed to have low small signal forward transconductance such that a large value of load resistor (R1) and a low value ceramic capacitor (<1μF) can be used for AC coupling (C1) in the frequency compensation network. The compensation network shown in Figure 2 will introduce a zero and a pole at:

$$f_z = \frac{1}{2\pi R_1 C_1} \quad f_p = \frac{1}{2\pi R_1 C_2} \quad (2)$$

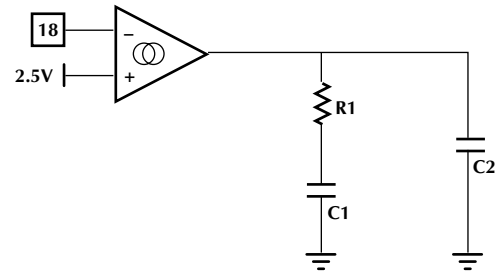

Figure 2. Compensation Network

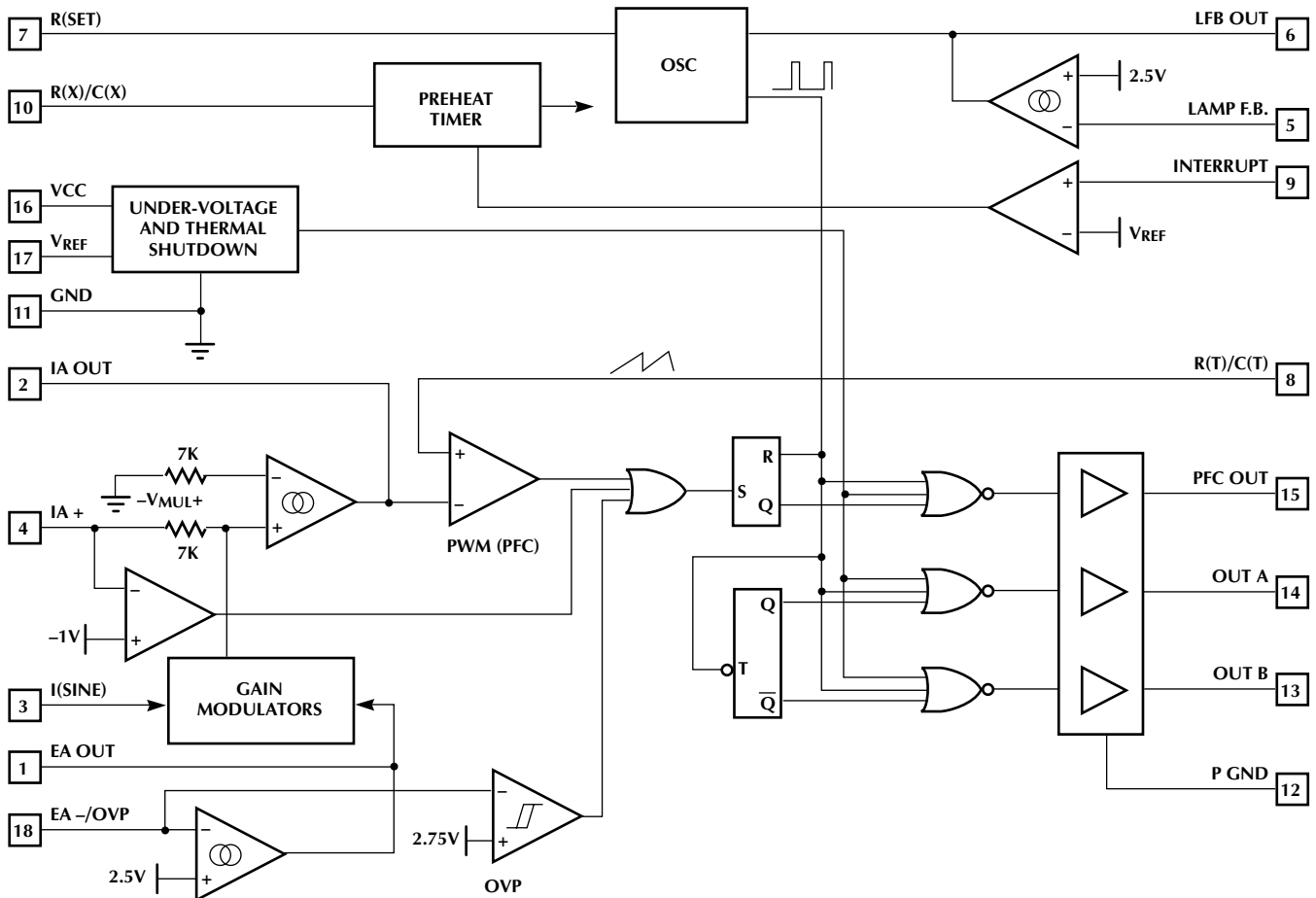

Figure 1. ML4831 Block Diagram

Figure 3 shows the output configuration for the operational transconductance amplifiers.

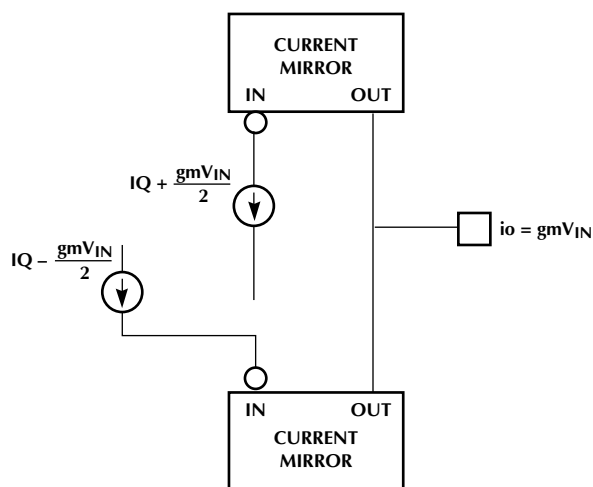

Figure 3. Output Configuration

A DC path to ground or VCC at the output of the transconductance amplifiers will introduce an offset error. The magnitude of the offset voltage that will appear at the input is given by $V_{OS} = i_o/g_m$. For a i_o of 1uA and a g_m of 0.08 μ mhos the input referred offset will be 12.5mV. Capacitor C1 as shown in Figure 2 is used to block the DC current to minimize the adverse effect of offsets.

Slew rate enhancement is incorporated into all of the operational transconductance amplifiers in the ML4831. This improves the recovery of the circuit in response to power up and transient conditions. The response to large signals will be somewhat non-linear as the transconductance amplifiers change from their low to high transconductance mode. This is illustrated in Figure 4.

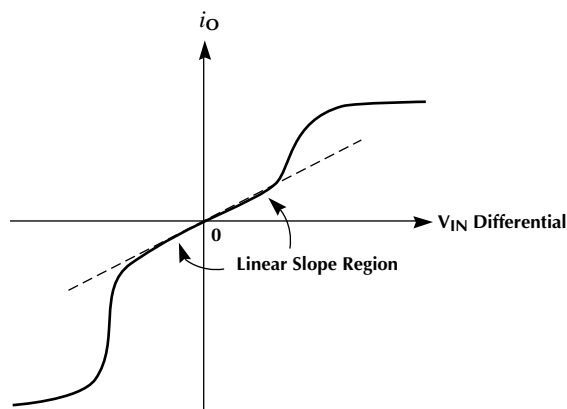

Figure 4. Transconductance Amplifier Characteristics

BALLAST OUTPUT SECTION

The IC controls output power to the lamps via frequency modulation with non-overlapping conduction. This means that both ballast output drivers will be low during the discharging time t_{DIS} of the oscillator capacitor C_T .

OSCILLATOR

The VCO frequency ranges are controlled by the output of the LFB amplifier (Pin 6). As lamp current decreases, Pin 6 rises in voltage, causing the C(T) charging current to decrease, thereby causing the oscillator frequency to decrease. Since the ballast output network attenuates high frequencies, the power to the lamp will be increased.

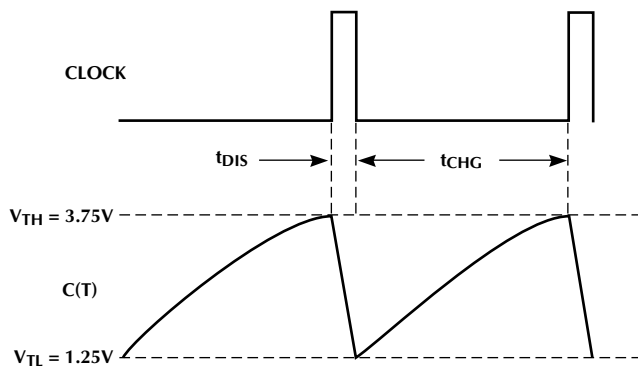
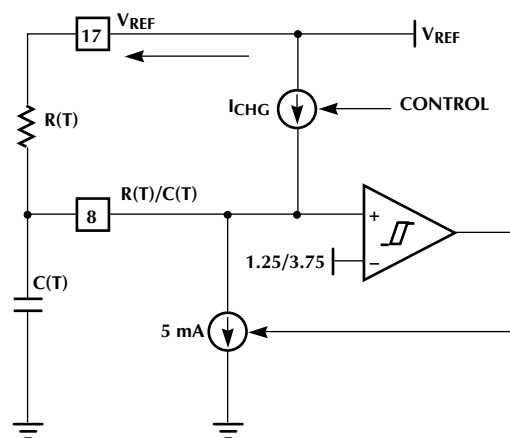

Figure 5. Oscillator Block Diagram and Timing

The oscillator frequency is determined by the following equations:

$$F_{OSC} = \frac{1}{t_{CHG} + t_{DIS}} \tag{3}$$

and

$$t_{CHG} = R_T C_T \ln \left(\frac{V_{REF} + I_{CH} R_T - V_{TL}}{V_{REF} + I_{CH} R_T - V_{TH}} \right) \tag{4}$$

The oscillator's minimum frequency is set when $I_{CH} = 0$ where:

$$F_{OSC} \cong \frac{1}{0.51 \times R_T C_T} \quad (5)$$

This assumes that $t_{CHG} \gg t_{DIS}$.

When LFB OUT is high, $I_{CH} = 0$ and the minimum frequency occurs. The charging current varies according to two control inputs to the oscillator:

1. The output of the preheat timer
2. The voltage at Pin 6 (lamp feedback amplifier output)

In preheat condition, charging current is fixed at

$$I_{CHG(PREHEAT)} = \frac{2.5}{R(SET)} \quad (6)$$

In running mode, charging current decreases as the V_{PIN6} rises from 0V to V_{OH} of the LAMP FB amplifier. The highest frequency will be attained when I_{CHG} is highest, which is attained when V_{PIN6} is at 0V:

$$I_{CHG(0)} = \frac{5}{R(SET)} \quad (7)$$

Highest lamp power, and lowest output frequency are attained when V_{PIN6} is at its maximum output voltage (V_{OH}).

In this condition, the minimum operating frequency of the ballast is set per (5) above.

For the IC to be used effectively in dimming ballasts with higher Q output networks a larger C_T value and lower R_T value can be used, to yield a smaller frequency excursion over the control range (V_{PIN6}). The discharge current is set to 5mA. Assuming that $I_{DIS} \gg I_{RT}$:

$$t_{DIS(VCO)} \cong 490 \times C_T \quad (8)$$

IC BIAS, UNDER-VOLTAGE LOCKOUT AND THERMAL SHUTDOWN

The IC includes a shunt regulator which will limit the voltage at V_{CC} to 13.5 (V_{CCZ}). The IC should be fed with a current limited source, typically derived from the ballast transformer auxiliary winding. When V_{CC} is below $V_{CCZ} - 0.7V$, the IC draws less than 1.7mA of quiescent current and the outputs are off. This allows the IC to start using a "bleed resistor" from the rectified AC line.

To help reduce ballast cost, the ML4831 includes a temperature sensor which will inhibit ballast operation if the IC's junction temperature exceeds 120°C. In order to use this sensor in lieu of an external sensor, care should be taken when placing the IC to ensure that it is sensing temperature at the physically appropriate point in the ballast. The ML4831's die temperature can be estimated with the following equation:

$$T_J \cong T_A \times P_D \times 65^\circ C/W \quad (9)$$

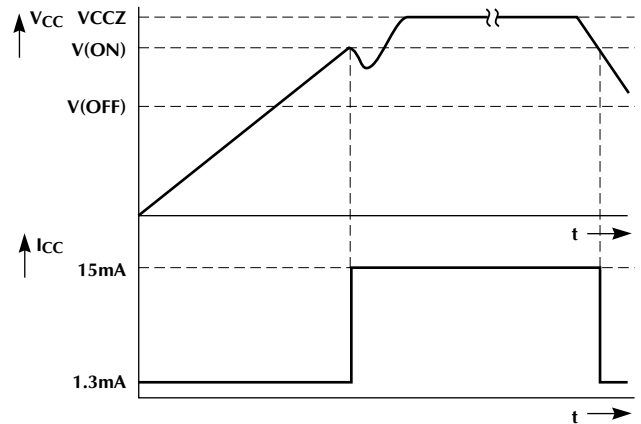

Figure 6. Typical V_{CC} and I_{CC} Waveforms when the ML4831 is Started with a Bleed Resistor from the Rectified AC Line and Bootstrapped from an Auxiliary Winding.

STARTING, RE-START, PREHEAT AND INTERRUPT

The lamp starting scenario implemented in the ML4831 is designed to maximize lamp life and minimize ballast heating during lamp out conditions.

The circuit in Figure 7 controls the lamp starting scenarios: Filament preheat and Lamp Out interrupt. C(X) is charged with a current of $I_{R(SET)}/4$ and discharged through R(X). The voltage at C(X) is initialized to 0.7V (V_{BE}) at power up. The time for C(X) to rise to 3.4V is the filament preheat time. During that time, the oscillator charging current (I_{CHG}) is $2.5/R(SET)$. This will produce a high frequency for filament preheat, but will not produce sufficient voltage to ignite the lamp.

After cathode heating, the inverter frequency drops to F_{MIN} causing a high voltage to appear to ignite the lamp. If the voltage does not drop when the lamp is supposed to have ignited, the lamp voltage feedback coming into Pin 9 rises to above V_{REF} , the C(X) charging current is shut off and the inverter is inhibited until C(X) is discharged by R(X) to the 1.2V threshold. Shutting off the inverter in this manner prevents the inverter from generating excessive heat when the lamp fails to strike or is out of socket. Typically this time is set to be fairly long by choosing a large value of R(X).

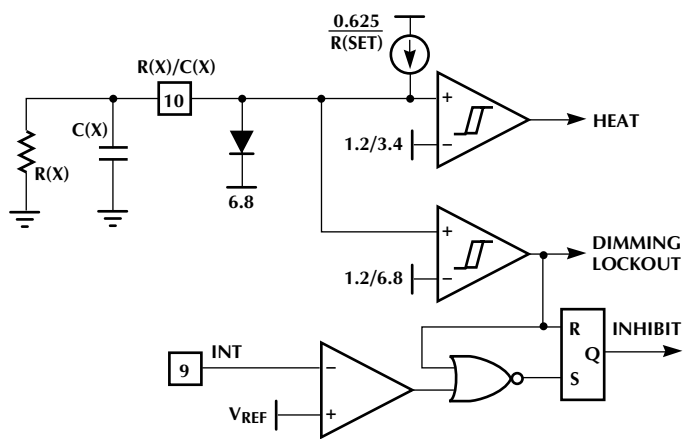

Figure 7. Lamp Preheat and Interrupt Timers

LFB OUT is ignored by the oscillator until C(X) reaches 6.8V threshold. The lamps are therefore driven to full power and then dimmed. The C(X) pin is clamped to about 7.5V.

A summary of the operating frequencies in the various operating modes is shown below.

Operating Mode	Operating Frequency
Preheat	$\frac{[F(\text{MAX}) \text{ to } F(\text{MIN})]}{2}$
Dimming Lock-out	F(MIN)
Dimming Control	F(MIN) to F(MAX)

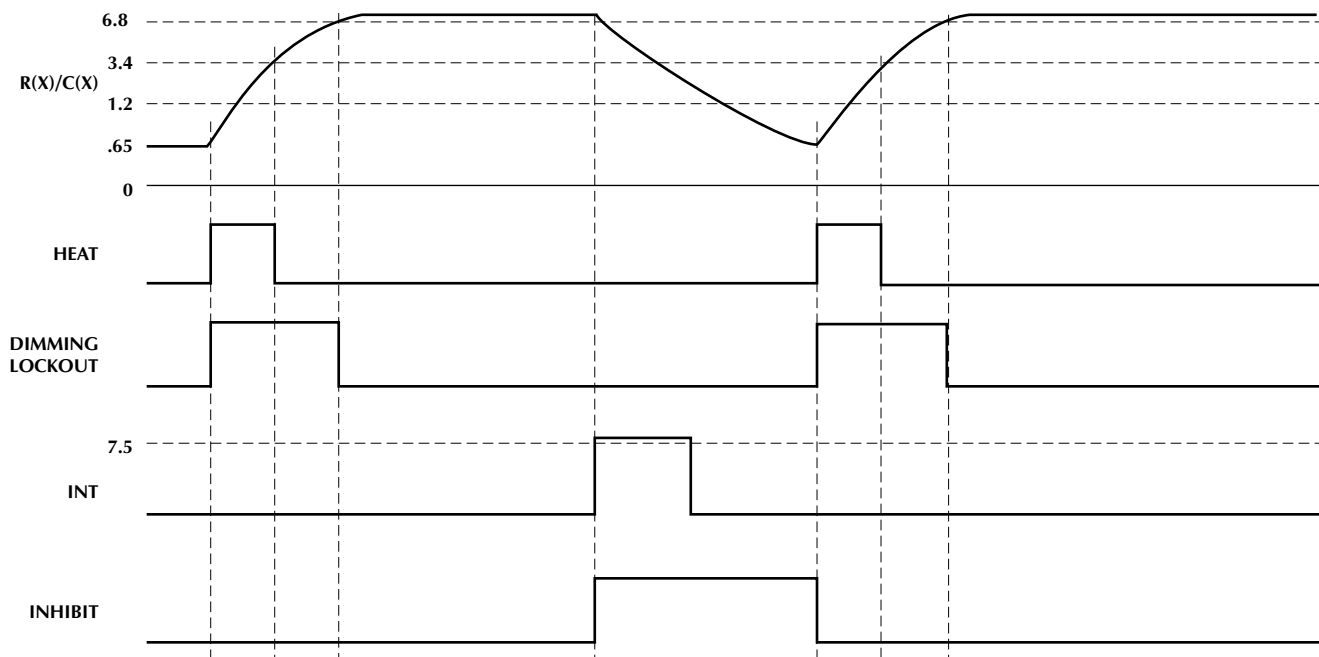

Figure 8. Lamp Starting and Restart Timing

APPLICATIONS POWER FACTOR CORRECTED FLUORESCENT DIMMING LAMP BALLAST

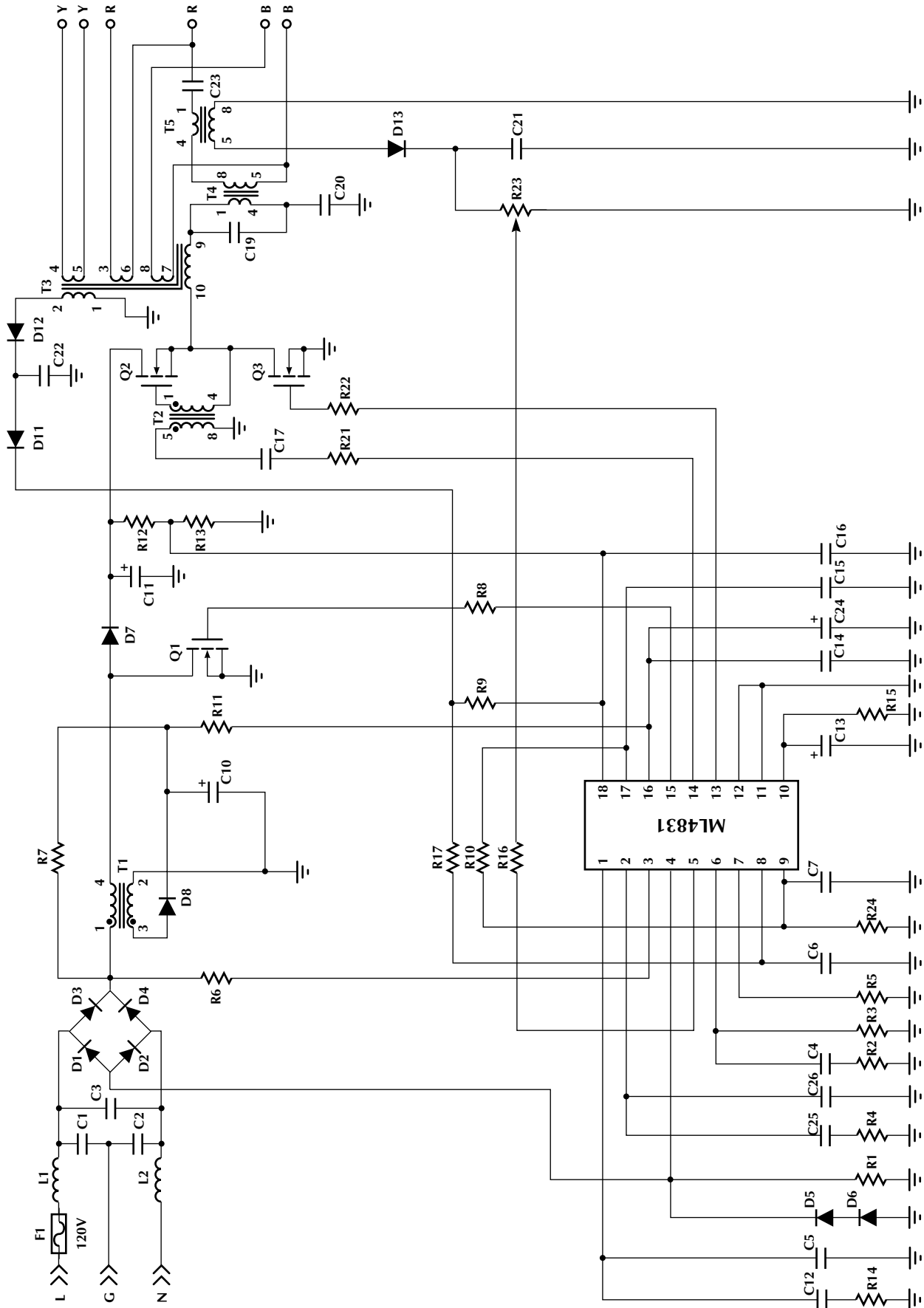

Figure 9. Typical Application: 2-Lamp Isolated Dimming Ballast with Active Power Factor Correction for 120VAC Input

TABLE 1: PARTS LIST FOR THE ML4831EVAL EVALUATION KIT

CAPACITORS				
QTY.	REF.	DESCRIPTION	MFR.	PART NUMBER
2	C1, 2	3.3nF, 125VAC, 10%, ceramic, "Y" capacitor	Panasonic	ECK-DNS332ME
1	C3	0.33 μ F, 250VAC, "X", capacitor	Panasonic	ECQ-U2A334MV
4	C4, 8, 9, 22	0.1 μ F, 50V, 10%, ceramic capacitor	AVX	SR215C104KAA
2	C5, 21	0.01 μ F, 50V, 10%, ceramic capacitor	AVX	SR211C103KAA
1	C6	1.5 μ F, 50V, 2.5%, NPO ceramic capacitor	AVX	RPE121COG152
2	C7, 12	1 μ F, 50V, 20%, ceramic capacitor	AVX	SR305E105MAA
1	C10	100 μ F, 25V, 20%, electrolytic capacitor	Panasonic	ECE-A1EFS101
1	C11	100 μ F, 250V, 20%, electrolytic capacitor	Panasonic	ECE-S2EG101E
1	C13	4.7 μ F, 50V, 20%, electrolytic capacitor	Panasonic	ECE-A50Z4R7
3	C14, 15, 17	0.22 μ F, 50V, 10%, ceramic capacitor	AVX	SR305C224KAA
1	C16	1.5 μ F, 50V, 10%, ceramic capacitor	AVX	SR151V152KAA
1	C19	22nF, 630V, 5%, polypropylene capacitor	WIMA	MKP10, 22nF, 630V, 5%
1	C20	0.1 μ F, 250V, 5%, polypropylene capacitor	WIMA	MKP10, 0.1 μ F, 250V, 5%
1	C23	0.068 μ F, 160V, 5%, polypropylene capacitor	WIMA	MKP4, 68nF, 160V, 5%
1	C24	220 μ F, 16V, 20%, electrolytic capacitor	Panasonic	ECE-A16Z220
1	C25	47nF, 50V, 10%, ceramic capacitor	AVX	SR211C472KAA
1	C26	330pF, 50V, 10%, ceramic capacitor	AVX	SR151A331JAA
RESISTORS:				
1	R1	0.33 Ω , 5%, 1/2W, metal film resistor	NTE	HWD33
1	R2	4.3K, 1/4W, 5%, carbon film resistor	Yageo	4.3K-Q
1	R3	47K, 1/4W, 5%, carbon film resistor	Yageo	47K-Q
1	R4	12K, 1/4W, 5%, carbon film resistor	Yageo	12K-Q
1	R5	20K, 1/4W, 1%, metal film resistor	Dale	SMA4-20K-1
1	R6	360K, 1/4W, 5%, carbon film resistor	Yageo	360K-Q
1	R7	36K, 1W, 5%, carbon film resistor	Yageo	36KW-1-ND
3	R8, 22, 11	22 Ω , 1/4W, 5%, carbon film resistor	Yageo	22-Q
1	R9	402K, 1/4W, 1%, metal film resistor	Dale	SMA4-402K-1
1	R10	17.8K, 1/4W, 1%, metal film resistor	Dale	SMA4-17.8K-1
1	R12	475K, 1/4W, 1%, metal film resistor	Dale	SMA4-475K-1
1	R13	5.49K, 1/4W, 1%, metal film resistor	Dale	SMA4-5.49K-1

TABLE 1: PARTS LIST FOR ML4831EVAL EVALUATION KIT (Continued)

RESISTORS: (Continued)

QTY.	REF.	DESCRIPTION	MFR.	PART NUMBER
4	R14, 17, 24, 25	100K, 1/4W, 5%, carbon film resistor	Yageo	100K-Q
1	R15	681K, 1/4W, 5%, carbon film resistor	Yageo	681K-Q
1	R16	10K, 1/4W, 1%, metal film resistor	Dale	SMA4-10K-1
1	R21	33Ω, 1/4W, 5%, carbon film resistor	Yageo	33-Q
1	R23	25K, pot (for dimming adjustment)	Bourns	3386P-253-ND

DIODES:

4	D1, 2, 3, 4	1A, 600V, 1N4007 diode (or 1N5061 as a substitute)	Motorola	1N4007TR
2	D5, 6	1A, 50V (or more), 1N4001 diodes	Motorola	1N4001TR
1	D7	3A, 400V, BYV26C or BYT03 400 fast recovery or MUR440 Motorola ultra Fast diode	GI	BYV26C
5	D8, 9, 11, 12, 13	0.1A, 75V, 1N4148 signal diode	Motorola	1N4148TR

IC's:

1	IC1	ML4831, Electronic Ballast Controller IC	Micro Linear	ML4831CP
---	-----	--	-----------------	----------

TRANSISTORS:

3	Q1, 2, 3	3.3A, 400V, IRF720 power MOSFET	IR	IR720
---	----------	---------------------------------	----	-------

MAGNETICS:

1	T1	T1 Boost Inductor, E24/25, 1mH, Custom Coils P/N 5039 or Coiltronics P/N CTX05-12538-1 E24/25 core set, TDK PC40 material 8-pin vertical bobbin (Cosmo #4564-3-419), Wind as follows: 195 turns 25AWG magnet wire, start pin #1, end pin #4 1 layer mylar tape 14 turns 26AWG magnet wire, start pin #3, end pin #2 NOTE: Gap for 1mH ±5%		
1	T2	T2 Gate Drive Xfmr, $L_{PRI} = 3\text{mH}$, Custom Coils P/N 5037 or Coiltronics P/N CTX05-12539-1 Toroid Magnetics YW-41305-TC Wind as follows: Primary = 25 turns 30AWG magnet wire, start pin #1, end pin #4 Secondary = 50 turns 30AWG magnet wire, start pin #5, end pin #8		

TABLE 1: PARTS LIST FOR ML4831EVAL EVALUATION KIT (Continued)**MAGNETICS:** (Continued)

QTY.	REF.	DESCRIPTION	MFR.	PART NUMBER
1	T3	T3 Inductor, $L_{PRI} = 1.66\text{mH}$, Custom Ciols P/N 5041 or Coiltronics P/N CTX05-12547-1 E24/25 core set, TDK PC40 material 10 pin horizontal bobbin (Plastron #0722B-31-80) Wind as follows: 1st: 170T of 25AWG magnet wire; start pin #10, end pin #9. 1 layer of mylar tape 2nd: 5T of #32 magnet wire; start pin #2, end pin #1 1 layer of mylar tape 3rd: 3T of #30 Kynar coated wire; start pin #4, end pin #5 4th: 3T of #30 Kynar coated wire; start pin #3, end pin #6 5th: 3T of #30 Kynar coated wire; start pin #7, end pin #8 NOTE: Gap for $1.66\text{mH} \pm 5\%$ (pins 9 to 10)		
1	T4	T4 Power Xfmr, $L_{PRI} = 3.87\text{mH}$, Custom Ciols P/N 5038 or Coiltronics P/N CTX05-12545-1 E24/25 core set, TDK PC40 material 8 pin vertical bobbin (Cosmo #4564-3-419) Wind as follows: 1st: 200T of 30AWG magnet wire; start pin #1, end pin #4. 1 layer of mylar tape 2nd: 300T of 32AWG magnet wire; start pin #5, end pin #8 NOTE: Gap for inductance primary: (pins 1 to 4) @ $3.87\text{mH} \pm 5\%$		
1	T5	T5 Current Sense Inductor, Custom Coils P/N 5040 or Coiltronics P/N CTX05-12546-1 Toroid Magnetics YW-41305-TC Wind as follows: Primary = 3T 30AWG magnet coated wire, start pin #1, end pin #4 Secondary = 400T 35AWG magnet wire, start pin #5, end pin #8		

INDUCTORS:

2	L1, 2	EMI/RFI Inductor, $600\mu\text{H}$, DC resistance = 0.45Ω Prem. Magnetics		SPE116A
---	-------	---	--	---------

FUSES:

1	F1	2A fuse, 5 x 20mm miniature	Littlefuse	F948-ND
2		Fuse Clips, 5 x 20mm, PC Mount		F058-ND

HARDWARE:

1		Single TO-220 Heatsink	Aavid Eng.	PB1ST-69
2		Double TO-220 Heatsink	IERC	PSE1-2TC
3		MICA Insulators	Keystone	4673K-ND

PHYSICAL DIMENSIONS inches (millimeters)

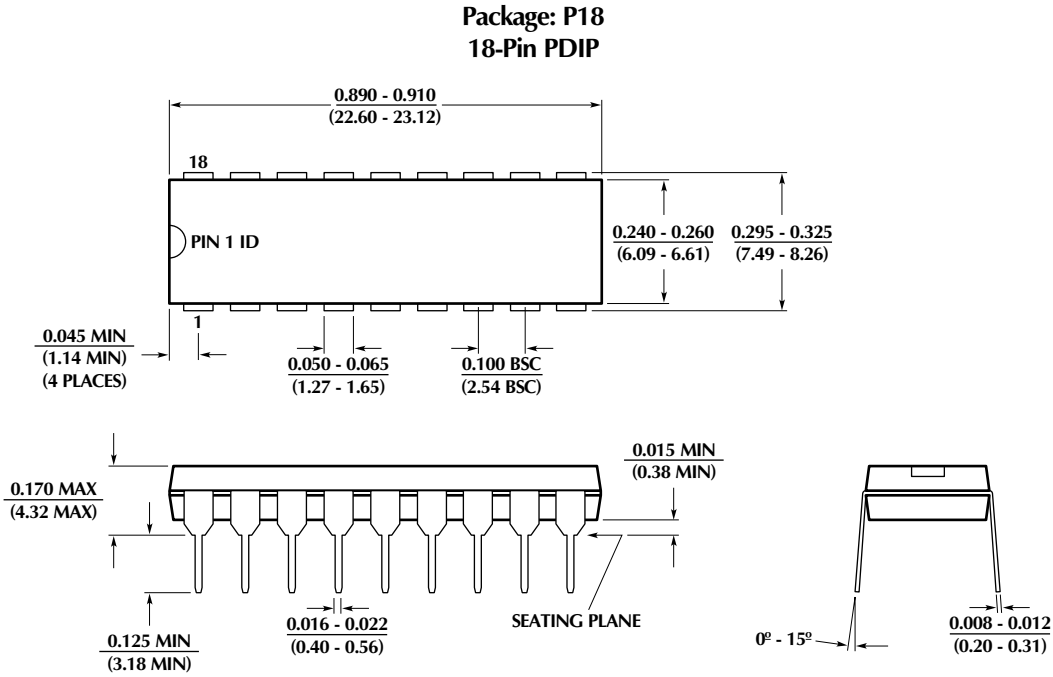

ORDERING INFORMATION

PART NUMBER	TEMPERATURE RANGE	PACKAGE
ML4831CP	0°C to 85°C	Molded PDIP (P18) (END OF LIFE)

© Micro Linear 1997. **Micro Linear** is a registered trademark of Micro Linear Corporation.

Products described in this document may be covered by one or more of the following patents, U.S.: 4,897,611; 4,964,026; 5,027,116; 5,281,862; 5,283,483; 5,418,502; 5,508,570; 5,510,727; 5,523,940; 5,546,017; 5,559,470; 5,565,761; 5,592,128; 5,594,376; Japan: 2598946. Other patents are pending.

Micro Linear reserves the right to make changes to any product herein to improve reliability, function or design. Micro Linear does not assume any liability arising out of the application or use of any product described herein, neither does it convey any license under its patent right nor the rights of others. The circuits contained in this data sheet are offered as possible applications only. Micro Linear makes no warranties or representations as to whether the illustrated circuits infringe any intellectual property rights of others, and will accept no responsibility or liability for use of any application herein. The customer is urged to consult with appropriate legal counsel before deciding on a particular application.

2092 Concourse Drive
San Jose, CA 95131
Tel: 408/433-5200
Fax: 408/432-0295