

High Voltage High Current Boost Regulator

GENERAL DESCRIPTION

The ML4865 is a high voltage, continuous conduction boost regulator designed for DC to DC conversion in multiple cell battery powered systems. Continuous conduction allows the regulator to maximize output current for a given inductor. The maximum switching frequency can exceed 200kHz, allowing the use of small, low cost inductors. The ML4865 is capable of start-up with input voltages as low as 1.8V and generates a 12V output with output voltage accuracy of $\pm 4\%$.

Unlike most boost regulators, the ML4865 isolates the load from the battery when the SHDN pin is high. An integrated synchronous rectifier eliminates the need for an external Schottky diode and provides a lower forward voltage drop, resulting in higher conversion efficiency. In addition, low quiescent battery current and variable frequency operation result in high efficiency even at light loads. The ML4865 requires only one inductor and two capacitors to build a very small regulator circuit capable of achieving conversion efficiencies approaching 90%.

FEATURES

- Guaranteed full load start-up and operation at 1.8V input
- Continuous conduction mode for high output current
- Very low quiescent current
- Pulse frequency modulation and internal synchronous rectification for high efficiency
- Maximum switching frequency > 200kHz
- Minimum external components
- Low ON resistance internal switching FETs
- Fixed 12V output can be adjusted to lower output voltages

BLOCK DIAGRAM

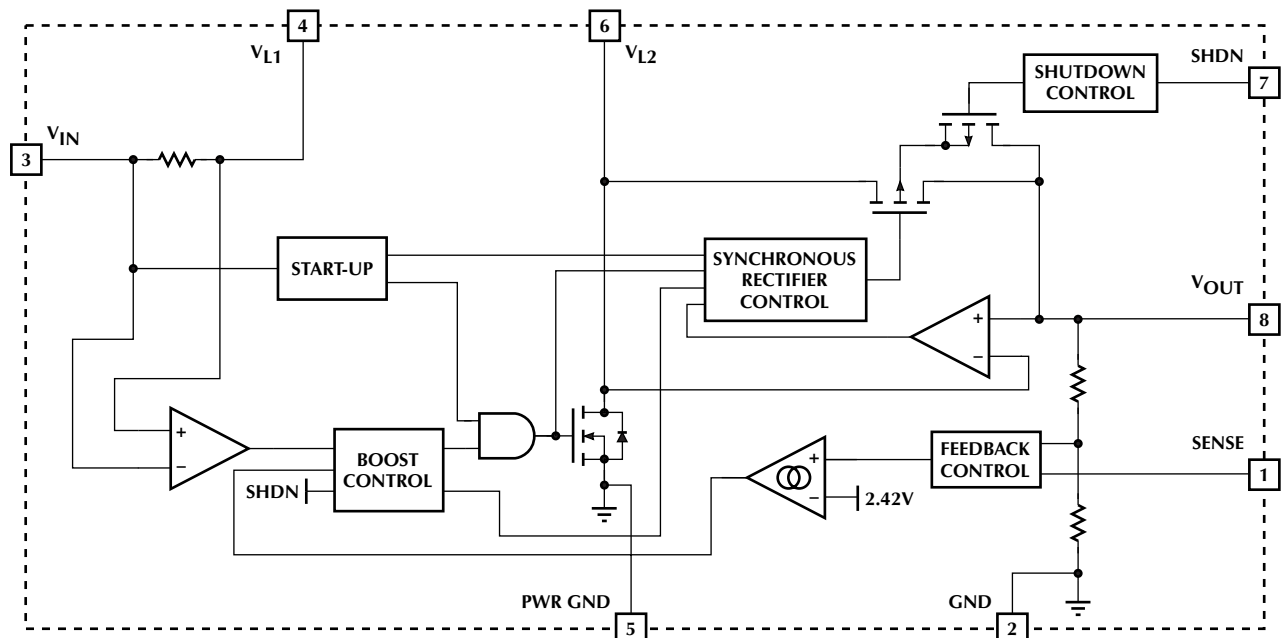

PIN CONFIGURATION

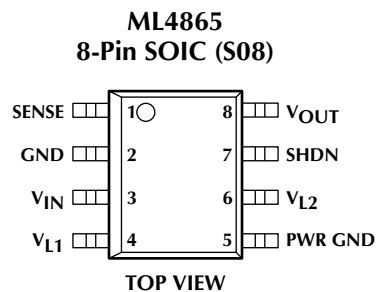

PIN DESCRIPTION

<i>PIN</i>	<i>NAME</i>	<i>FUNCTION</i>	<i>PIN</i>	<i>NAME</i>	<i>FUNCTION</i>
1	SENSE	Programming pin for setting the output to any value lower than the normal fixed voltage	5	PWR GND	Return for the internal power transistors
2	GND	Ground	6	VL2	Boost inductor connection
3	VIN	Battery input voltage	7	SHDN	Pulling this pin to VIN through an external resistor shuts down the regulator, isolating the load from the input.
4	VL1	Boost inductor connection	8	VOUT	Boost regulator output

ABSOLUTE MAXIMUM RATINGS

Absolute maximum ratings are those values beyond which the device could be permanently damaged. Absolute maximum ratings are stress ratings only and functional device operation is not implied.

Voltage on any Pin	GND – 0.3V to 16.5V
Peak Switch Current (I_{PEAK})	2A
Average Switch Current (I_{AVG})	1A
Junction Temperature	150°C
Storage Temperature Range	–65°C to 150°C
Lead Temperature (Soldering, 10 sec)	150°C
Thermal Resistance (θ_{JA})	160°C/W

OPERATING CONDITIONS

Temperature Range	
ML4865CS-2	0°C to 70°C
ML4865ES-2	–20°C to 70°C
V_{IN} Voltage Range	
Without external rectifier	1.8V to 6V
With external rectifier	1.8V to 10V

ELECTRICAL CHARACTERISTICS

Unless otherwise specified, V_{IN} = Operating Voltage Range, T_A = Operating Temperature Range (Note 1)

SYMBOL	PARAMETER	CONDITIONS	MIN	TYP	MAX	UNITS
SUPPLY						
I_{IN}	V_{IN} Current	SHDN = 0 or V_{IN}		10	25	μ A
	V_{OUT} Quiescent Current	$V_{OUT} = V_{OUT(MAX)} + 5\%$		20	30	μ A
	V_L Quiescent Current	$0V < V_{L2} < V_{OUT}$	–1		1	μ A
PFM REGULATOR						
$I_L(PEAK)$	I_L Peak Current	$V_{IN} = 5V$	0.8	1.2	1.6	A
V_{OUT}	Output Voltage	See Figure 1 $V_{IN} = 5V$, SENSE = open, $I_{OUT} = 0$	11.72	12.1	12.48	V
	Load Regulation	See Figure 1 $V_{IN} = 2.4V$, $I_{OUT} = 40mA$ $V_{IN} = 5V$, $I_{OUT} = 160mA$	11.52 11.52	12.0 12.0		V V
FEEDBACK						
	Threshold Voltage		2.38	2.42	2.48	V
	Input Bias Current		–150		150	nA
SHUTDOWN						
	Threshold Voltage	$V_{SHDN} = \text{high to low}$	0.4	0.8	1.6	V
	Input Bias Current		–150		150	nA

Note 1: Limits are guaranteed by 100% testing, sampling, or correlation with worst-case test conditions.

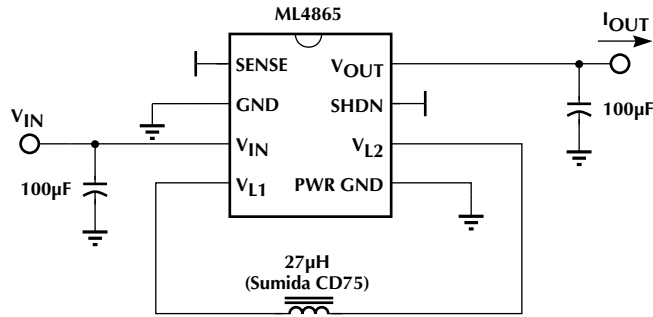

Figure 1. Application Test Circuit

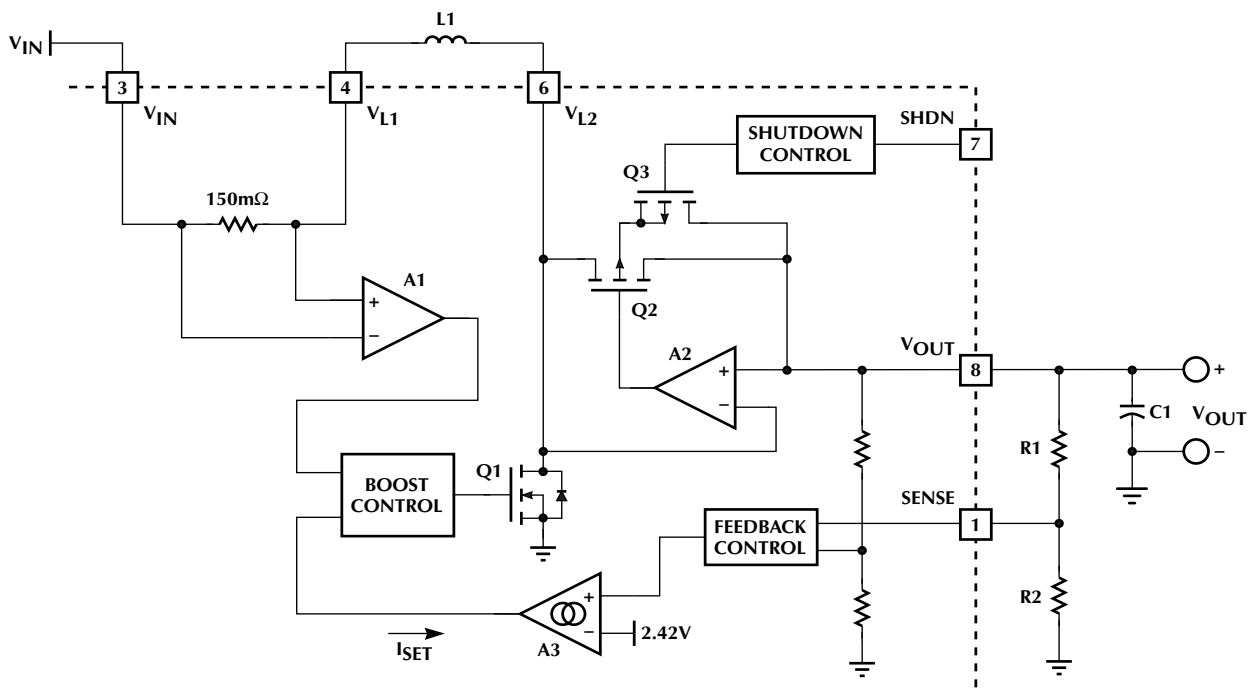

Figure 2. PFM Regulator Detailed Block Diagram

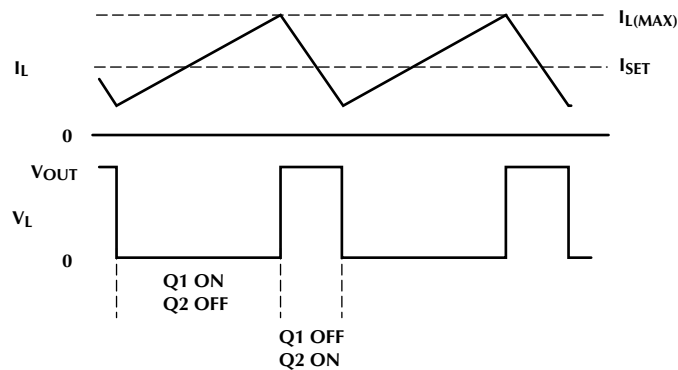

Figure 3. Inductor Current and Voltage Waveforms

FUNCTIONAL DESCRIPTION

The ML4865 combines a unique form of current mode control with a synchronous rectifier to create a boost converter that can deliver high currents while maintaining high efficiency. Current mode control allows the use of a very small, high frequency inductor and output capacitor. Synchronous rectification replaces the conventional external Schottky diode with an on-chip PMOS FET to reduce losses, eliminate an external component, and allows for load disconnect. Also included on-chip are an NMOS switch and current sense resistor, further reducing the number of external components, which makes the ML4865 very easy to use.

REGULATOR OPERATION

The ML4865 is a variable frequency, current mode switching regulator. Its unique control scheme converts efficiently over more than three decades of load current. A detailed block diagram of the boost converter is shown in Figure 2.

Error amplifier A3 converts deviations in the desired output voltage to a small current, I_{SET} . The inductor current is measured through a $150\text{m}\Omega$ resistor which is amplified by A1. The boost control block matches the average inductor current to a multiple of the I_{SET} current by switching Q1 on and off. The peak inductor current is limited by the controller to about 1.2A.

At light loads, I_{SET} will momentarily reach zero after an inductor discharge cycle causing Q1 to stop switching. Depending on the load, this idle time can extend to tenths of seconds. While the circuit is not switching, only $25\mu\text{A}$ of supply current is drawn from the output. This allows the part to remain efficient even when the load current drops below $250\mu\text{A}$.

Amplifier A2 and the PMOS transistor Q2 work together to form a low drop diode. When transistor Q1 turns off, the current flowing in the inductor causes pin 6 to go high. As the voltage on V_{L2} rises above V_{OUT} , amplifier A2 allows the PMOS transistor Q2 to turn on. In discontinuous operation, (where I_L always returns to zero), A2 uses the resistive drop across the PMOS switch Q2 to sense zero inductor current and turns the PMOS switch off. In continuous operation, the PMOS turn off is independent of A2 and is determined by the boost control circuitry.

Typical inductor current and voltage waveforms are shown in Figure 3.

SHUTDOWN

The SHDN pin should be held low for normal operation. Raising the shutdown voltage above the threshold level will disable the synchronous rectifier, Q2 and Q3, and force I_{SET} to zero. This prevents switching from occurring and disconnects the body diode of Q2 from the output. As a result, the output voltage is allowed to drop below the input voltage and current is prevented from flowing from the input to the output.

FEEDBACK

The SENSE pin should be left open or bypassed to ground for normal operation. The addition of the resistor divider R1 and R2 causes the input of error amplifier A3 to reach the threshold voltage before the internal resistors do. This allows the ML4865 to provide output voltages lower than the preset 12V if desired.

DESIGN CONSIDERATIONS

INPUT VOLTAGE RANGE

The input voltage range determines whether an external Schottky diode is necessary or optional. If the input voltage is 6V or lower, the ML4865 can be operated as a stand alone boost regulator with a shutdown that fully isolates the input from the output. Adding an optional Schottky diode extends the input voltage range up to 10V, and improves the efficiency and the output current capability. However, the external diode now provides a leakage path from the input to the output during shutdown.

OUTPUT CURRENT CAPABILITY

The maximum current available at the output of the regulator is related to the maximum inductor current by the ratio of the input to output voltage and the full load efficiency. The maximum inductor current is dependent on the input voltage. The full load efficiency may be as low as 65% when the ML4865 is used without a Schottky diode and can exhibit an input voltage dependence when an external diode is used. The maximum output current can be determined by using the typical performance curves shown in Figures 4 and 5, or by calculation using the following empirical equation:

$$I_{OUT(MAX)} \cong \frac{V_{IN}}{V_{OUT}} \times I_{IN} \times \eta \quad (1)$$

Where, for applications using the internal synchronous rectifier:

$$I_{OUT(MAX)} \cong \frac{V_{IN}}{V_{OUT}} \times ((0.05 \times V_{IN}) + 0.4) \times 0.65$$

$$I_{IN} = 0.05 \times V_{IN} + 0.4$$

$$\eta = 0.65$$

And for applications using an external Schottky:

$$I_{OUT(MAX)} \cong \frac{V_{IN}}{V_{OUT}} \times ((0.07 \times V_{IN}) + 0.4) \times ((0.025 \times V_{IN}) + 0.65)$$

$$I_{IN} = 0.07 \times V_{IN} + 0.4$$

$$\eta = 0.025 \times V_{IN} + 0.65$$

The curves and the equations are based on the operating circuit shown in Figure 7. It is recommended to verify the current capability and efficiency for the components selected.

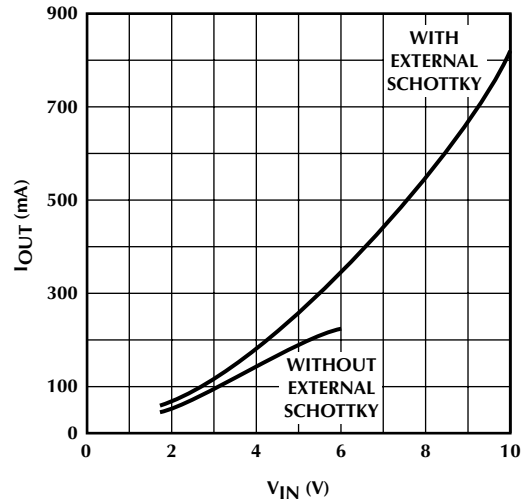

Figure 4. Output Current vs. Input Voltage

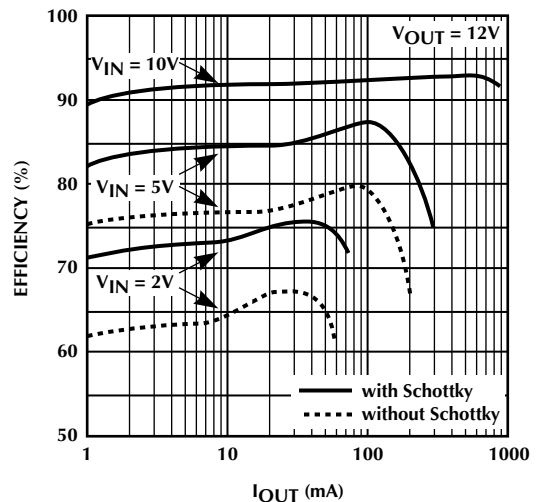

Figure 5. Efficiency vs. Output Current

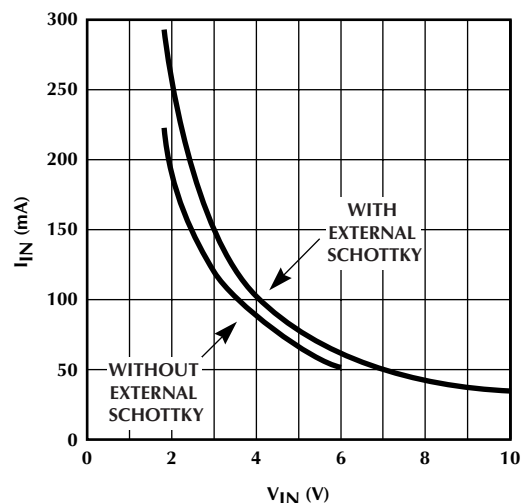

Figure 6. No Load Input Current vs. Input Voltage for the Circuit of Figure 7

DESIGN CONSIDERATIONS (Continued)**INDUCTOR SELECTION**

The ML4865 is able to operate over a wide range of inductor values. A value of 22 μ H or 33 μ H is a good choice, but any value between 15 μ H and 50 μ H is acceptable. As the inductor value is changed the control circuitry will automatically adjust to keep the inductor current under control. Choosing an inductance value of less than 15 μ H will reduce the component's footprint, but the efficiency and maximum output current may drop.

It is important to use an inductor that is rated to handle 1.5A peak currents without saturating. Also look for an inductor with low winding resistance. A good rule of thumb is to allow 5 to 10m Ω of resistance for each μ H of inductance.

The final selection of the inductor will be based on trade-offs between size, cost and efficiency. Inductor tolerance, core and copper loss will vary with the type of inductor selected and should be evaluated with a ML4865 under worst case conditions to determine its suitability.

Several manufacturers supply standard inductance values in surface mount packages:

Coilcraft	(847) 639-6400
Coiltronics	(561) 241-7876
Dale	(605) 665-9301
Sumida	(847) 956-0666

OUTPUT CAPACITOR

The output capacitor filters the pulses of current from the switching regulator. Since the switching frequency will vary with inductance, the minimum output capacitance required to reduce the output ripple to an acceptable level will be a function of the inductor used. Therefore, to maintain an output voltage with less than 100mV of ripple (due to capacitance) at full load current, use the following equation:

$$C_{OUT} = \frac{10 \times L}{V_{OUT}} \quad (F) \quad (2)$$

The output capacitor's Equivalent Series Resistance (ESR) and Equivalent Series Inductance (ESL), also contribute to the ripple. Just after the NMOS transistor, Q1, turns off, the current in the output capacitor ramps quickly to between 0.5A and 1.5A. This fast change in current through the capacitor's ESL causes a high frequency (5ns) spike to appear on the output. After the ESL spike settles, the output still has a ripple component equal to the inductor discharge current times the ESR. To minimize these effects, choose an output capacitor with less than 10nH of ESL and 200m Ω of ESR.

Suitable tantalum capacitors can be obtained from the following vendors:

AVX	TPS Series	(207) 282-5111
Sprague	593D Series	(207) 324-4140
Kemet	T495 Series	(864) 963-6300

INPUT CAPACITOR

Due to the high input current drawn at startup and possibly during operation, it is recommended to decouple the input with a capacitor with a value of 22 μ F to 68 μ F. This filtering prevents the input ripple from affecting the ML4865 control circuitry, and also improves the efficiency by reducing the I squared R losses during the charge cycle of the inductor. Again, a low ESR capacitor (such as tantalum) is recommended.

It is also recommended that low source impedance batteries be used. Otherwise, the voltage drop across the source impedance during high input current situations will cause the ML4865 to fail to start-up or to operate unreliably. In general, for two cell applications the source impedance should be less than 200m Ω , which means that small alkaline cells should be avoided.

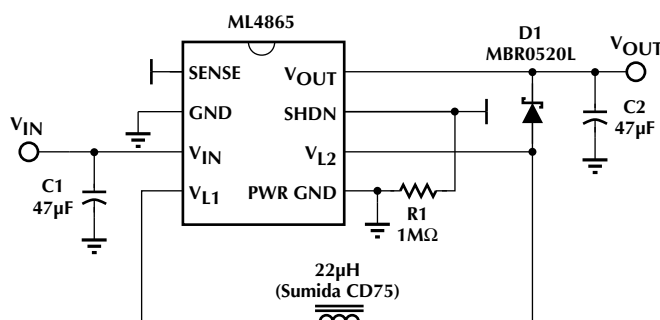

Figure 7. Typical Application Circuit.

DESIGN CONSIDERATIONS (Continued)

SHUTDOWN

The SHDN pin is a high impedance input and is noise sensitive. Either drive the SHDN input from a low impedance source or bypass the pin to GND with a 10nF ceramic capacitor.

SENSE

The SENSE pin should be left open or bypassed to ground for normal operation. The output can be set to voltages lower than the preset value by adding a resistor divider. The output voltage can be determined from the following equation:

$$V_{OUT} = 2.42 \times \frac{R1 + R2}{R2} \text{ (V)} \quad (3)$$

where R1 and R2 are connected as shown in Figure 2. The value of R2 should be 1M Ω or less to minimize bias current errors. Choose an appropriate value of R2 and calculate the value of R1.

$$R1 = R2 \times \left(\frac{V_{OUT}}{2.42} - 1 \right) \text{ (\Omega)} \quad (4)$$

EXTERNAL SCHOTTKY RECTIFIER

Due to excessive power dissipation, an external Schottky rectifier is required when operating at input voltages above 6V. Even for applications where the input voltage is below 6V, the use of an external rectifier may be necessary to achieve efficiency or output current requirements.

If an external Schottky is required, look for a device with a voltage rating of 20V or greater. The average forward current rating should be at least 500mA, and the forward voltage should be 600mV or less. Suitable Schottky rectifiers can be obtained from the following vendors:

Diodes, Inc	B120	(805) 446-4800
Int'l Rectifier	10BQ040	(310) 322-3331
Motorola	MBR0520L	(602) 897-5056

LAYOUT

Good layout practices will ensure the proper operation of the ML4865. Some layout guidelines follow:

- Use adequate ground and power traces or planes
- Keep components as close as possible to the ML4865
- Use short trace lengths from the inductor to the V_{L1} and V_{L2} pins and from the output capacitor to the V_{OUT} pin
- Use a single point ground for the ML4865 ground pin, and the input and output capacitors
- Separate the ground for the converter circuitry from the ground of the load circuitry and connect at a single point

A sample layout is shown in Figure 8.

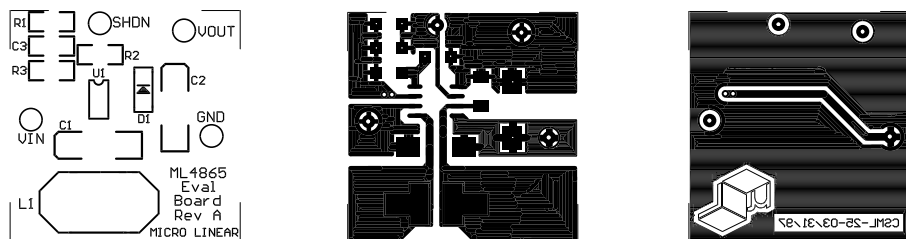

Figure 8. Sample ML4865 Layout

DESIGN EXAMPLE

In order to design a boost converter using the ML4865, it is necessary to define the values of a few parameters. For this example, assume the following design parameters:

$$V_{IN} = 4.75 \text{ to } 5.25\text{V}$$

$$V_{OUT} = 12\text{V}$$

$$I_{OUT(MAX)} = 150\text{mA}$$

Shutdown required

First, it must be determined whether the ML4865 is capable of delivering the output current without an external Schottky rectifier. This is done using Equation 1:

$$I_{OUT(MAX)} \cong \frac{V_{IN}}{V_{OUT}} \times ((0.05 \times V_{IN}) + 0.4) \times 0.65$$

$$I_{OUT(MAX)} \cong \frac{5.25}{12} \times ((0.05 \times 5.25) + 0.4) \times 0.65 = 188\text{mA}$$

Next, select an inductor. As previously mentioned, the recommended inductance is 22 μ H. Make sure that the peak current rating of the inductor is at least 1.5A, and that the DC resistance of the inductor is in the range of 110 to 220m Ω . A Sumida CD75-220 meets these requirements.

Finally, the value of the output capacitor is determined using Equation 2:

$$C_{OUT} = \frac{10 \times L}{V_{OUT}} = \frac{10 \times 22\mu\text{H}}{12\text{V}} = 18.3\mu\text{F}$$

The closest standard value would be a 22 μ F capacitor with an ESR rating of 200m Ω . An AVX TPSD226M025R0200 would be a good choice.

As mentioned previously, the use of an input supply bypass capacitor is highly recommended. Since the output capacitance meets the minimum input capacitance recommended it can also be used for the input.

ML4865

PHYSICAL DIMENSIONS inches (millimeters)

Package: S08
8-Pin SOIC

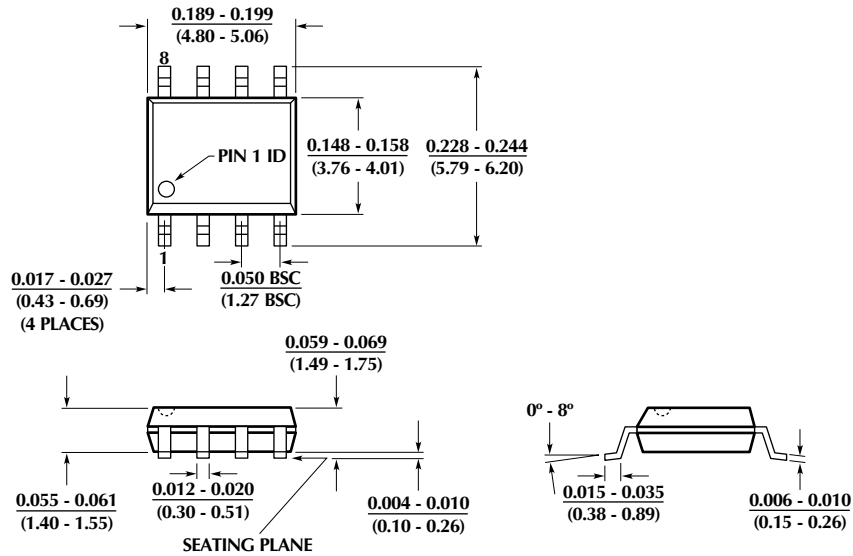

ORDERING INFORMATION

PART NUMBER	OUTPUT VOLTAGE	TEMPERATURE RANGE	PACKAGE
ML4865CS-2	12V	0°C to 70°C	8-Pin SOIC (S08)
ML4865ES-2 (Obsolete)	12V	-20°C to 70°C	8-Pin SOIC (S08)

© Micro Linear 1998. Micro Linear is a registered trademark of Micro Linear Corporation. All other trademarks are the property of their respective owners.

Products described herein may be covered by one or more of the following U.S. patents: 4,897,611; 4,964,026; 5,027,116; 5,281,862; 5,283,483; 5,418,502; 5,508,570; 5,510,727; 5,523,940; 5,546,017; 5,559,470; 5,565,761; 5,592,128; 5,594,376; 5,652,479; 5,661,427; 5,663,874; 5,672,959; 5,689,167; 5,714,897; 5,717,798; 5,742,151; 5,754,012; 5,757,174. Japan: 2,598,946; 2,619,299; 2,704,176. Other patents are pending.

Micro Linear reserves the right to make changes to any product herein to improve reliability, function or design. Micro Linear does not assume any liability arising out of the application or use of any product described herein, neither does it convey any license under its patent right nor the rights of others. The circuits contained in this data sheet are offered as possible applications only. Micro Linear makes no warranties or representations as to whether the illustrated circuits infringe any intellectual property rights of others, and will accept no responsibility or liability for use of any application herein. The customer is urged to consult with appropriate legal counsel before deciding on a particular application.

2092 Concourse Drive
San Jose, CA 95131
Tel: 408/433-5200
Fax: 408/432-0295
www.microlinear.com