

# ML9XX31 SERIES

InGaAsP DFB-LASER DIODE WITH EA MODULATOR

Notice: Some parametric limits are subject to change.

**TYPE  
NAME**

**ML9SM31**

## DESCRIPTION

ML9XX31 series are DFB (Distributed Feedback) laser diodes with a monolithically integrated EA modulator, suitable light source for 10Gbps or 2.5Gbps application (Single channel / DWDM).

Available wavelengths are from 1530nm to 1565nm with 0.8nm spacing.

ML9SM31 is supplied with the chip-on-carrier type package.

## FEATURES

- Available distance  
ML9SM31-01 series : 50km(Max) at 10Gbps  
ML9SM31-02 series : 700km(Max) at 2.5Gbps
- High extinction ratio (Min. 11dB at 2.5Gbps, Typ. 11dB at 10Gbps)
- High - side mode suppression ratio (Typ. 40dB)
- High speed response (Typ. 30psec)

## APPLICATION

2.5Gbps long-haul transmission system  
10Gbps transmission system

## ABSOLUTE MAXIMUM RATINGS

Symbol	Parameter	Conditions	Ratings	Unit
$I_F$	Forward current (Laser diode)	CW	200	mA
$V_{RL}$	Reverse voltage (Laser diode)	-	2	V
$V_{EA}$	Reverse voltage (Modulator)	-	-3	V
Tc	Case temperature	-	+15 to +35	degC
Tstg	Storage temperature	-	-40 to +100	degC

www.DataSheet4U.com

## ELECTRICAL/OPTICAL CHARACTERISTICS (Tc=25degC)

Symbol	Parameter	Test Conditions	Min.	Typ.	Max.	Unit
Ith	Threshold current	CW, Vmod=0V	---	10	30	mA
Iop	Operation current	CW, Po=5mW, Vmod=0V	---	60	90	mA
Vop	Operating voltage	CW, Po=5mW, Vmod=0V	---	1.2	1.8	V
$\lambda_p$	Peak wavelength	CW, If>Iop, Vmod=0V	-0.4	code list	+0.4	nm
$\theta_{//}$	Beam divergence angle (parallel)	CW, Po=5mW, Vmod=0V	---	30	---	deg.
$\theta_{\perp}$	Beam divergence angle (perpendicular)	CW, Po=5mW, Vmod=0V	---	45	---	deg.
Pm	Monitoring output power	CW, Po=5mW, Vmod=0V	---	1.0	---	mW

### ML9SM31-01 series for 10Gbps

fc	Cut off frequency	CW, If>Iop, Vmod=-1V	10	14	---	GHz
tr,tf	Rise and fall time (10%-90%)	9.95328Gbps, NRZ, PRBS 2 <sup>23</sup> -1	---	30	40	psec
SMSR	Side mode suppression ratio	If>Iop, Vpp=2.5V,	35	40	---	dB
Ex	Extinction ratio	Voffset=0 to -1.0V	10	11	---	dB
Pp	Dispersion penalty	ditto SMF 50km @BER=10 <sup>-10</sup>	---	---	2.0	dB

### ML9SM31-02 series for 2.5Gbps

fc	Cut off frequency	CW, If>Iop, Vmod=-1V	4	---	---	GHz
tr,tf	Rise and fall time (10%-90%)	2.48832Gbps, NRZ, PRBS 2 <sup>23</sup> -1	---	---	120	psec
SMSR	Side mode suppression ratio	If>Iop, Vpp=2.5V,	35	40	---	dB
Ex	Extinction ratio	Voffset=0 to -1.0V	11	---	---	dB
Pp	Dispersion penalty	ditto SMF 700km @BER=10 <sup>-10</sup>	---	---	2.0	dB

MITSUBISHI LASER DIODES  
**ML9XX31 SERIES**

InGaAsP DFB-LASER DIODE WITH EA MODULATOR

Notice: Some parametric limits are subject to change.

**OUTLINE DRAWINGS**

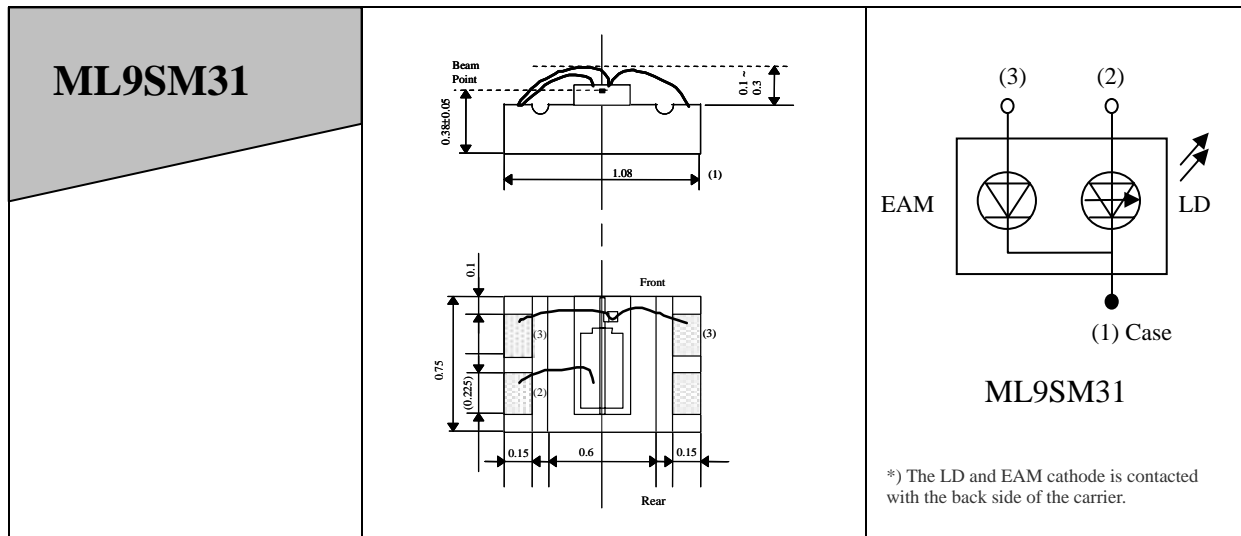

**Wavelength code list**

Code	Wavelength(nm)
00	1530 to 1565

← non WDM (single channel)

Code	Wavelength(nm)	Code	Wavelength(nm)
01	1529.55	24	1547.72
02	1530.33	25	1548.51
03	1531.12	26	1549.32
04	1531.90	27	1550.12
05	1532.68	28	1550.92
06	1533.47	29	1551.72
07	1534.25	30	1552.52
08	1535.04	31	1553.33
09	1535.82	32	1554.13
10	1536.61	33	1554.94
11	1537.40	34	1555.75
12	1538.19	35	1556.55
13	1538.98	36	1557.36
14	1539.77	37	1558.17
15	1540.56	38	1558.98
16	1541.35	39	1559.79
17	1542.14	40	1560.61
18	1542.94	41	1561.42
19	1543.73	42	1562.23
20	1544.53	43	1563.05
21	1545.32	44	1563.86
22	1546.12	45	1564.68
23	1546.92	46	1565.50

**Ordering information**

